

COLOR CODE FOR TUBES	
COLOR	CIRCUIT
RED	SECONDARY
GREEN	PRIMARY & SUPPLY
YELLOW	PARKING BRAKE
BLUE	SUSPENSION
BLACK	ACCESSORIES

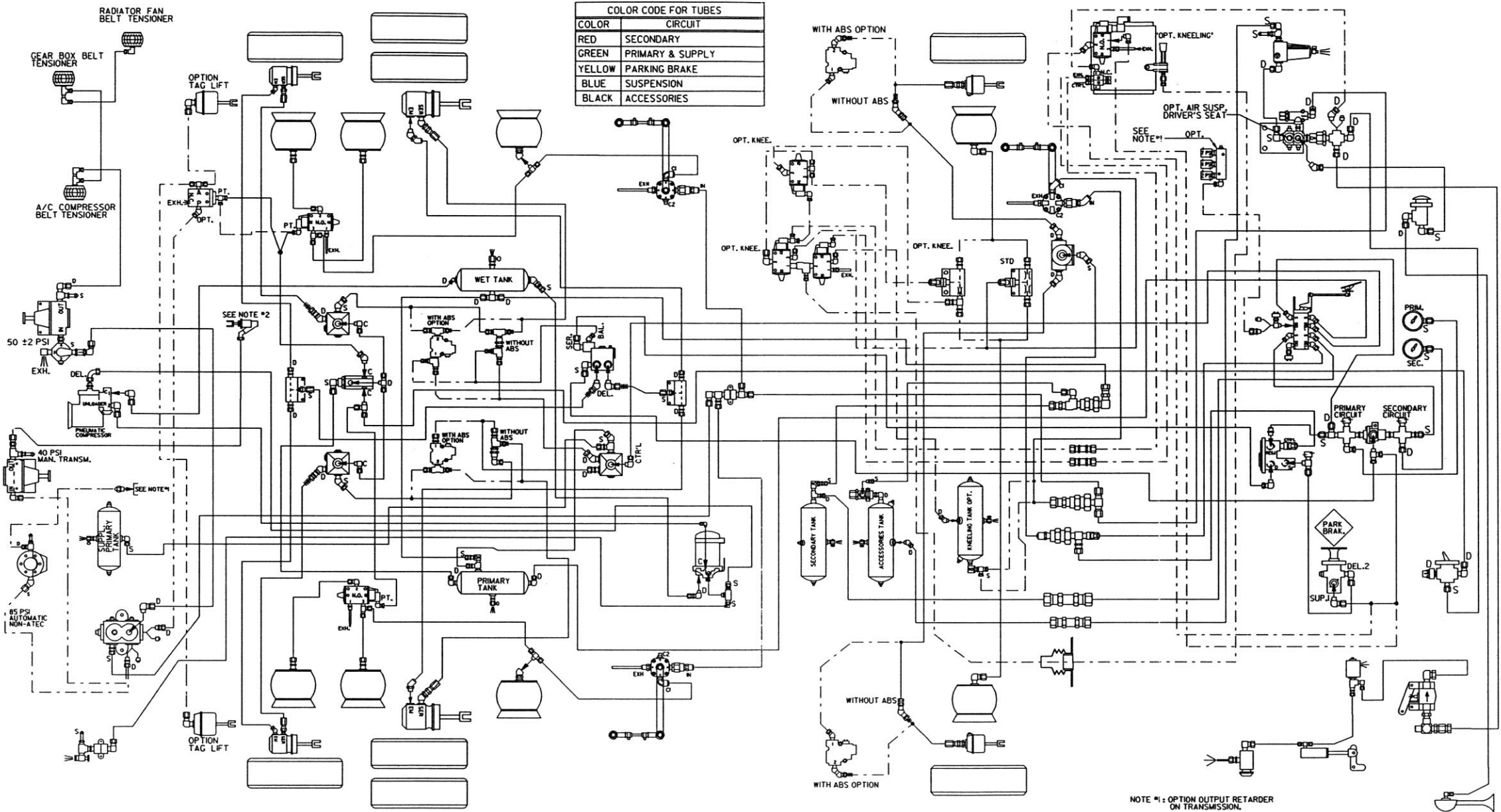

NOTE #1 : OPTION OUTPUT RETARDER ON TRANSMISSION.
 #2 : POWERED-ASSISTED CLUTCH.
 #3 : N.O. =NORMALLY OPEN
 N.C. =NORMALLY CLOSE