

NOTES: 1) WITH "OUTPUT RETARDER" ON TRANSMISSION AUTOMATIC WORLD
 2) N.O. - NORMALLY OPEN
 N.C. - NORMALLY CLOSED

CURRENT COLOR	SECONDARY CIRCUIT
→ → → RED	PRIMARY & SUPPLY
→ → → GREEN	PRIMARY & SUPPLY
→ → → YELLOW	PARKING BRAKE
→ → → BLUE	SUSPENSION
→ → → BLACK	ACCESSORIES

D140260 REV. A

BUS SHELL XL2 SERIES 60
 INDEPENDENT FRONT SUSPENSION (I.F.S.)

PROTOTYPE VEHICLE : *W-6451
 PRELIMINARY VEHICLE NO.1 : *Y-6856
 PRELIMINARY VEHICLE NO.2 : *Y-6924

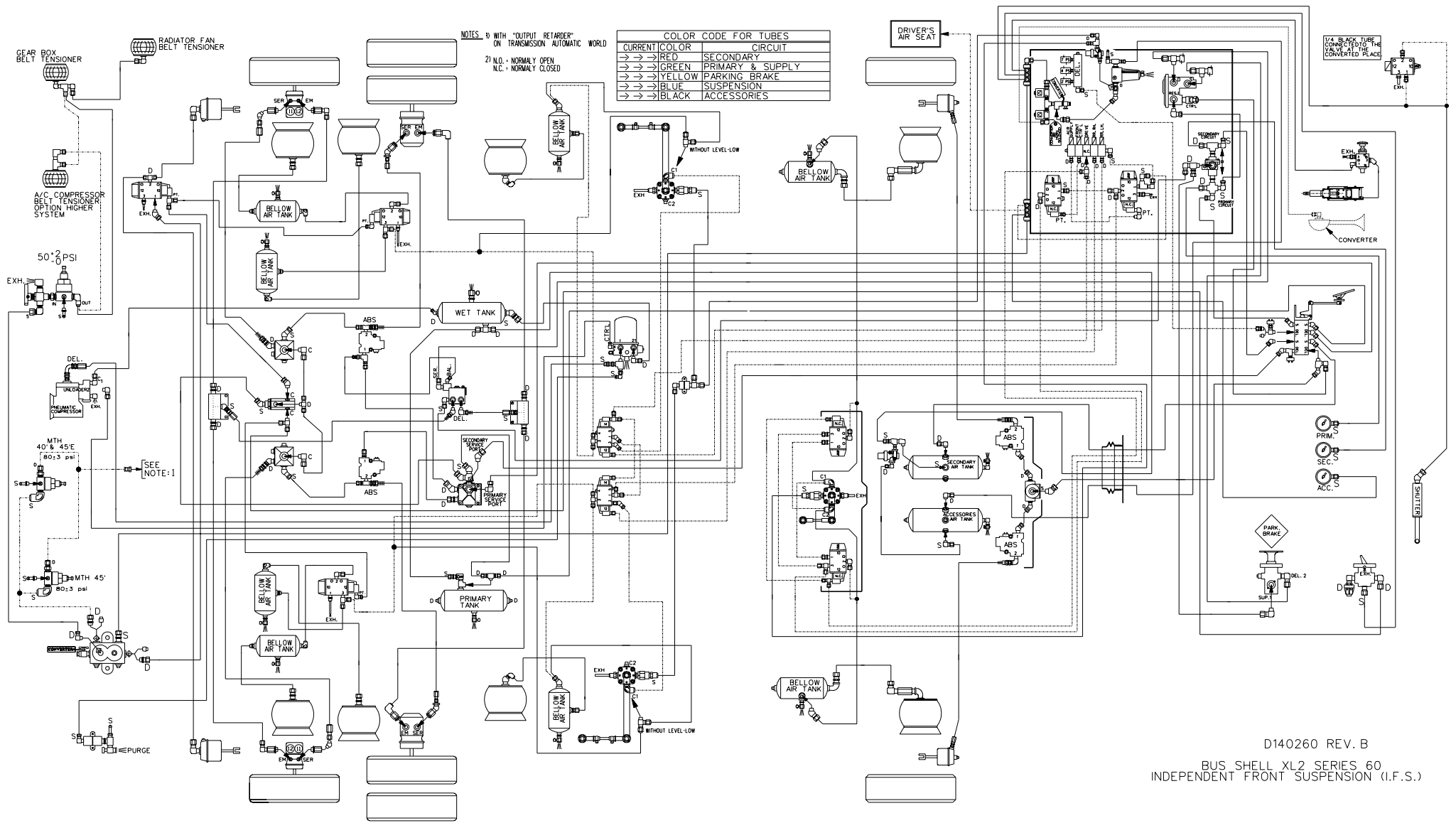

NOTES: 1) WITH "OUTPUT RETARDER" ON TRANSMISSION - AUTOMATIC WORLD
 2) N.O. - NORMALLY OPEN
 N.C. - NORMALLY CLOSED

CURRENT COLOR	SECONDARY CIRCUIT
→ RED	→ GREEN
→ GREEN	→ YELLOW
→ YELLOW	→ BLUE
→ BLUE	→ BLACK
→ BLACK	

1/4" BLACK TUBE CONNECTED TO THE CONVERTER PLACE

D140260 REV. B
 BUS_SHELL_XL2 SERIES 60
 INDEPENDENT FRONT SUSPENSION (I.F.S.)

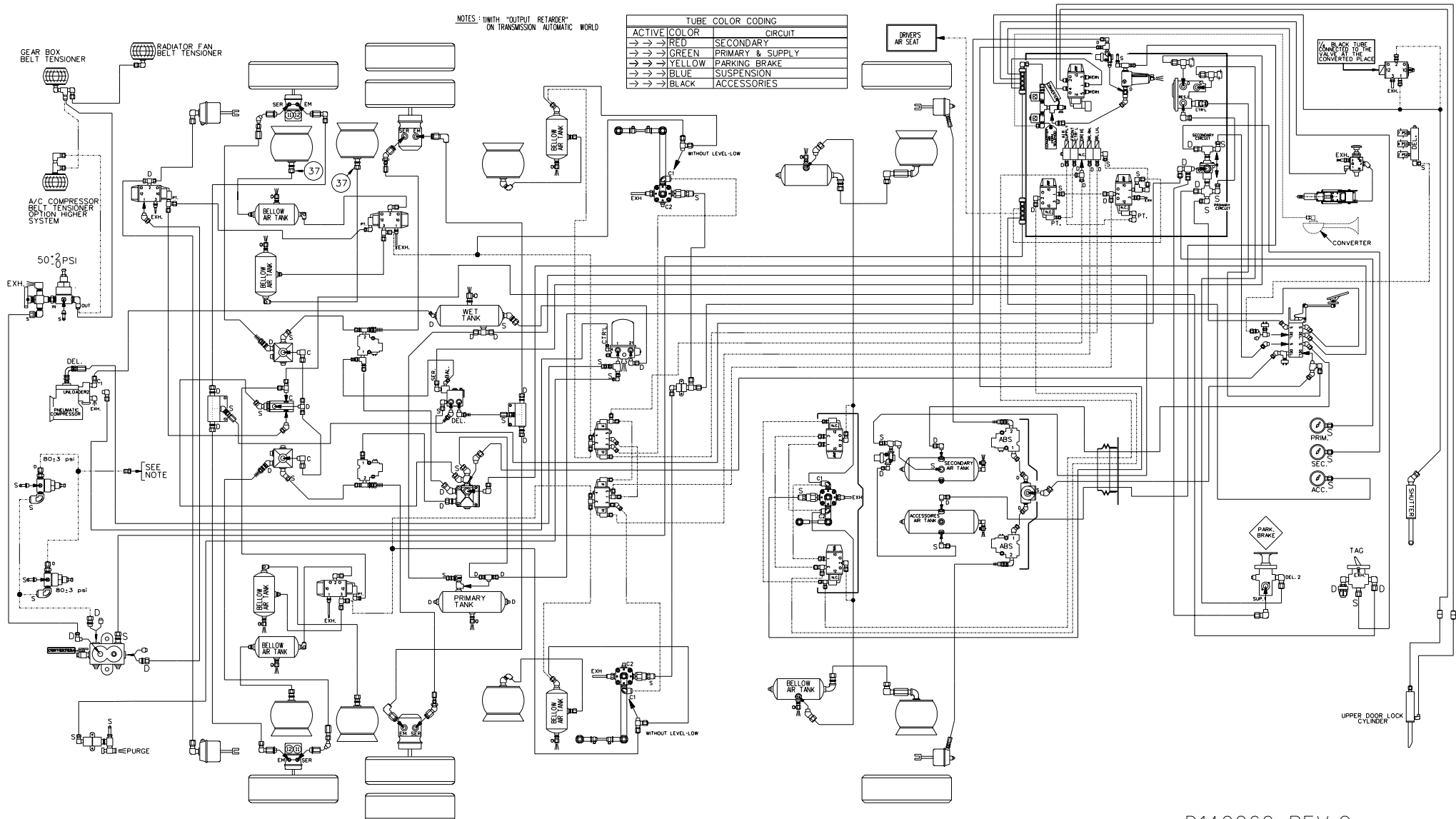

NOTES : WITH "OUTPUT RETARDER"
ON TRANSMISSION AUTOMATIC WORLD

ACTIVE COLOR	SECONDARY CIRCUIT
→→→ RED	→→→ SECONDARY
→→→ GREEN	→→→ PRIMARY & SUPPLY
→→→ YELLOW	→→→ PARKING BRAKE
→→→ BLUE	→→→ SUSPENSION
→→→ BLACK	→→→ ACCESSORIES

GEAR BOX BELT TENSIONER
RADIATOR FAN BELT TENSIONER

A/C COMPRESSOR BELT TENSIONER OPTION HIGHER SYSTEM

50 PSI

SEE NOTE

80.3 psi

80.3 psi

REPURGE

BLACK TUBE CONNECTED TO THE VALVE AT THE CONVERTER PLACE

CONVERTER

PRIM
SEC.
ACC.

PARK BRAKE

DEL. 2

UPPER DOOR LOCK CYLINDER

DATE: 01/2000

D140260 REV.C
BUS SHELL XL2 SERIES 60
INDEPENDENT FRONT SUSPENSION (I.F.S.)

NOTES: WITH "OUTPUT DELAYED"
ON TRANSMISSION AUTOMATIC WORLD

ACTIVE COLOR	CIRCUIT
→ → → RED	SECONDARY
→ → → GREEN	PRIMARY & SUPPLY
→ → → YELLOW	PARKING BRAKE
→ → → BLUE	SUSPENSION
→ → → BLACK	ACCESSORIES

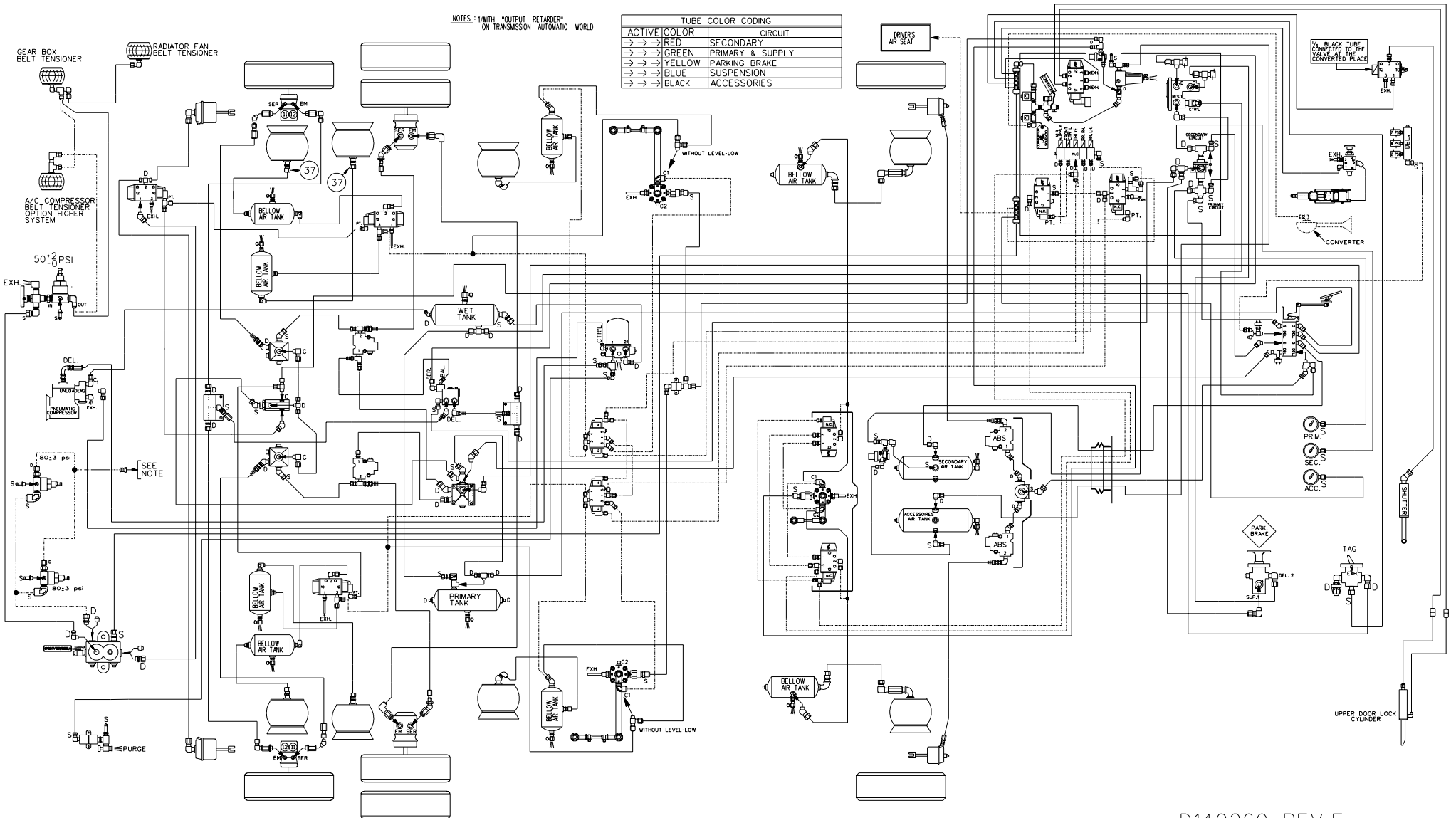

DATE: 04/2001

D140260 REV.F
 BUS SHELL XL2 SERIES 60
 INDEPENDENT FRONT SUSPENSION (I.F.S.)

NOTES: D WITH "OUTPUT RETARDER"
ON TRANSMISSION AUTOMATIC WORLD

TUBE COLOR CODING		
ACTIVE COLOR	COLOR	CIRCUIT
→ →	RED	SECONDARY
→ →	GREEN	PRIMARY & SUPPLY
→ →	YELLOW	PARKING BRAKE
→ →	BLUE	SUSPENSION
→ →	BLACK	ACCESSORIES

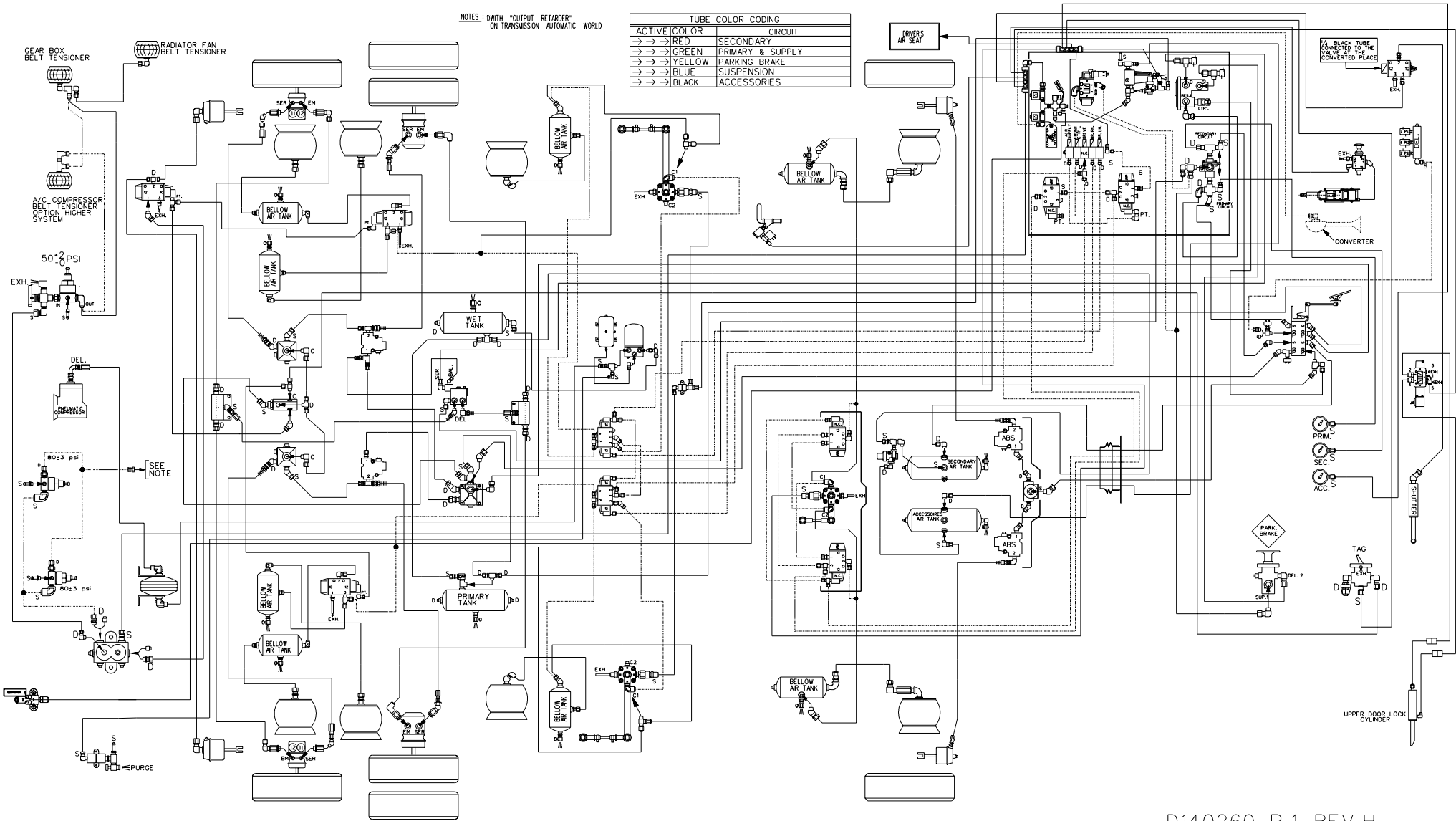

DATE: 11/2001

D140260 P.1 REV.H
 BUS SHELL XL2 SERIES 60
 INDEPENDENT FRONT SUSPENSION (I.F.S.)

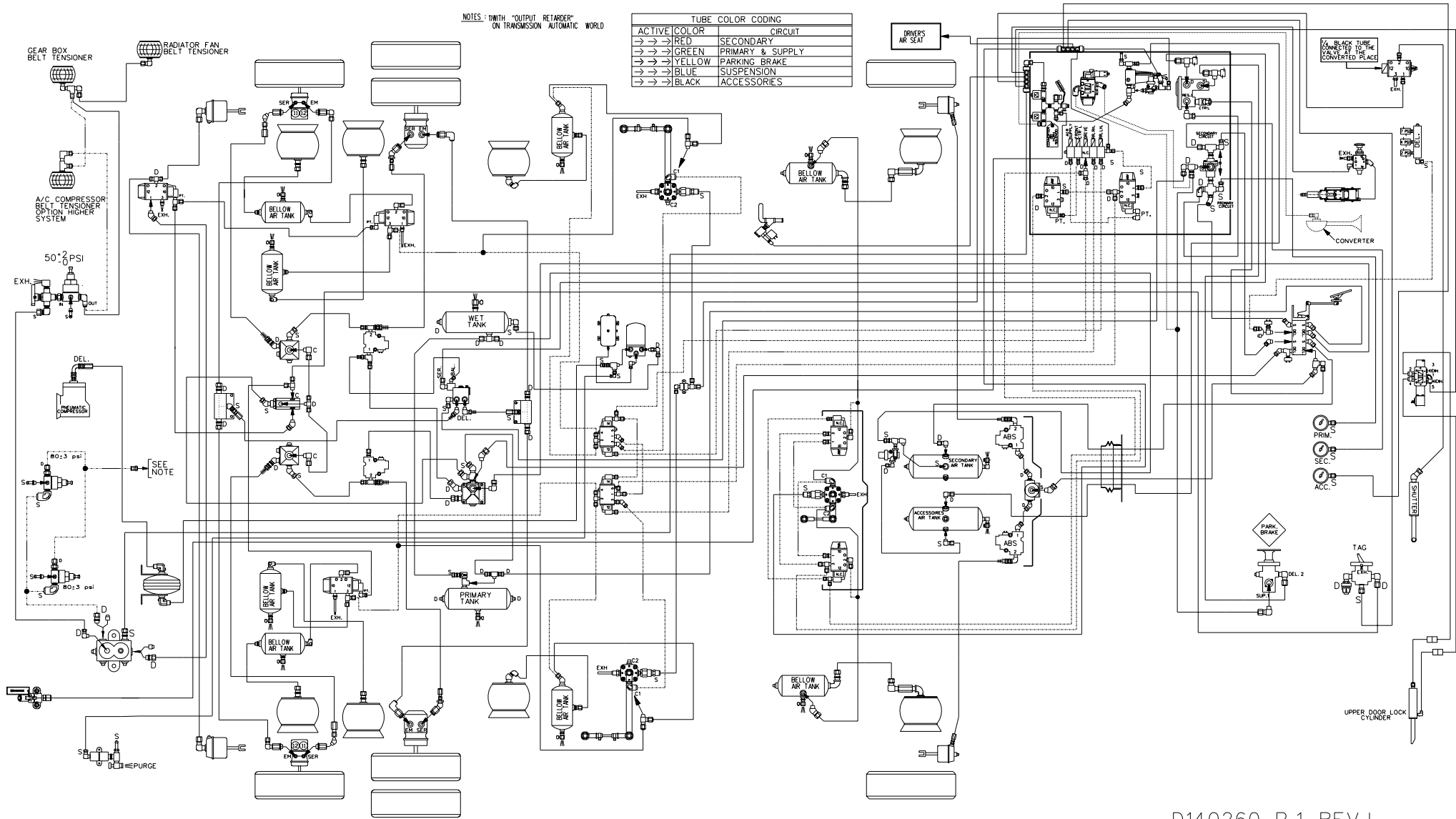

NOTES: *WITH "OUTPUT RETARDER" ON TRANSMISSION AUTOMATIC WORLD

TUBE COLOR CODING	
ACTIVE COLOR	SECONDARY CIRCUIT
→ → → RED	→ → → GREEN PRIMARY & SUPPLY
→ → → GREEN	→ → → YELLOW PARKING BRAKE
→ → → YELLOW	→ → → BLUE SUSPENSION
→ → → BLUE	→ → → BLACK ACCESSORIES

*BLACK TUBE CONNECTED TO THE CONVERSION CONVERTED BLACK

D140260 P.1 REV.1
 BUS SHELL XL2 SERIES 60
 INDEPENDENT FRONT SUSPENSION (I.F.S.)

DATE: 11/2001

NOTES : WITH "OUTPUT RETARDER"
ON TRANSMISSION AUTOMATIC WORLD

ACTIVE COLOR	CIRCUIT
→ → RED	SECONDARY
→ → GREEN	PRIMARY & SUPPLY
→ → YELLOW	PARKING BRAKE
→ → BLUE	SUSPENSION
→ → BLACK	ACCESSORIES

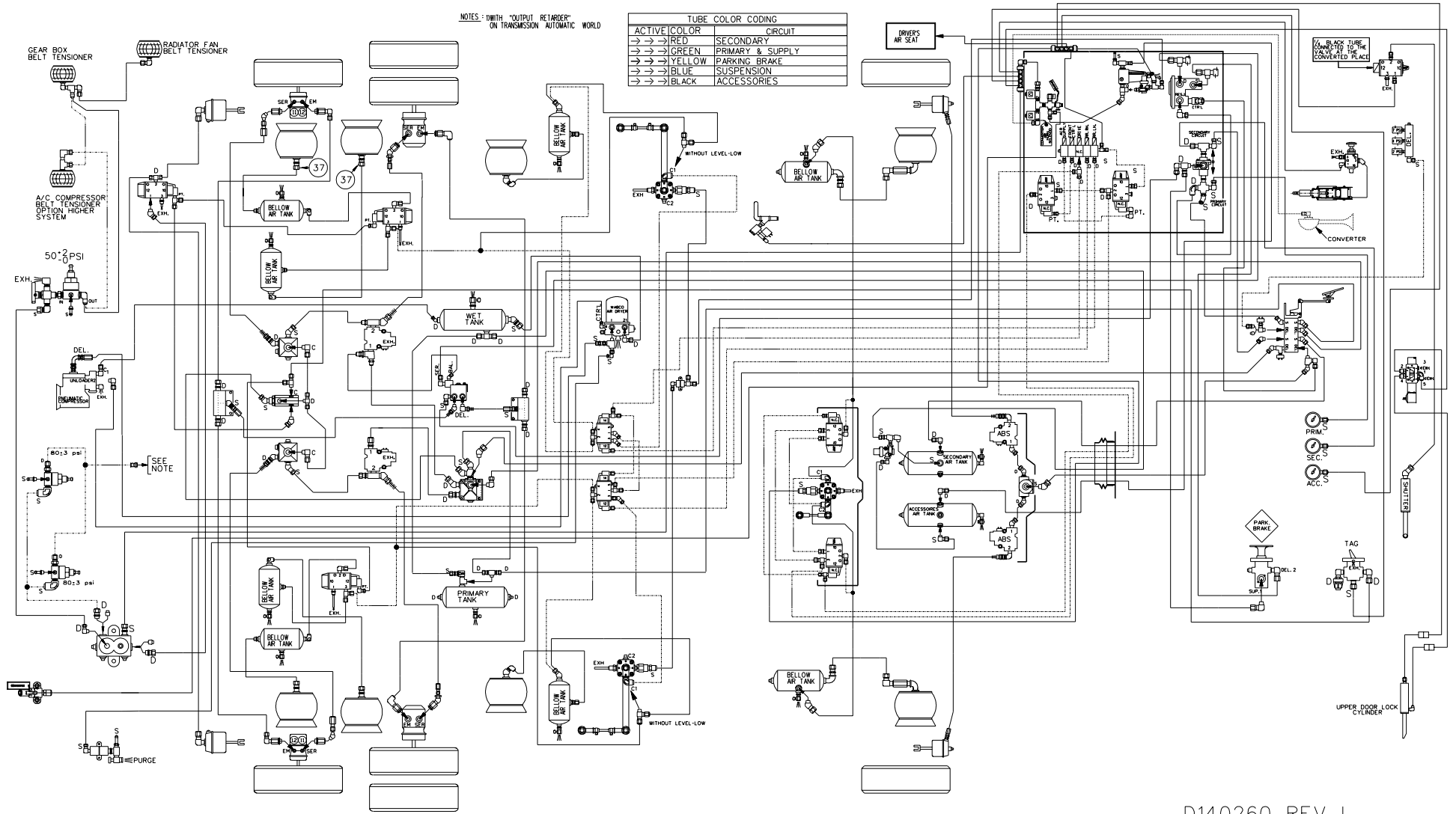

D140260 REV.J

BUS SHELL XL2 SERIES 60
INDEPENDENT FRONT SUSPENSION (I.F.S.)

DATE: 05/2002

NOTES : 1) WITH "OUTPUT RETARDER"
ON TRANSMISSION "AUTOMATIC WORLD"

ACTIVE	COLOR	CIRCUIT
→ →	RED	SECONDARY
→ →	GREEN	PRIMARY & SUPPLY
→ →	YELLOW	PARKING BRAKE
→ →	BLUE	SUSPENSION
→ →	BLACK	ACCESSORIES

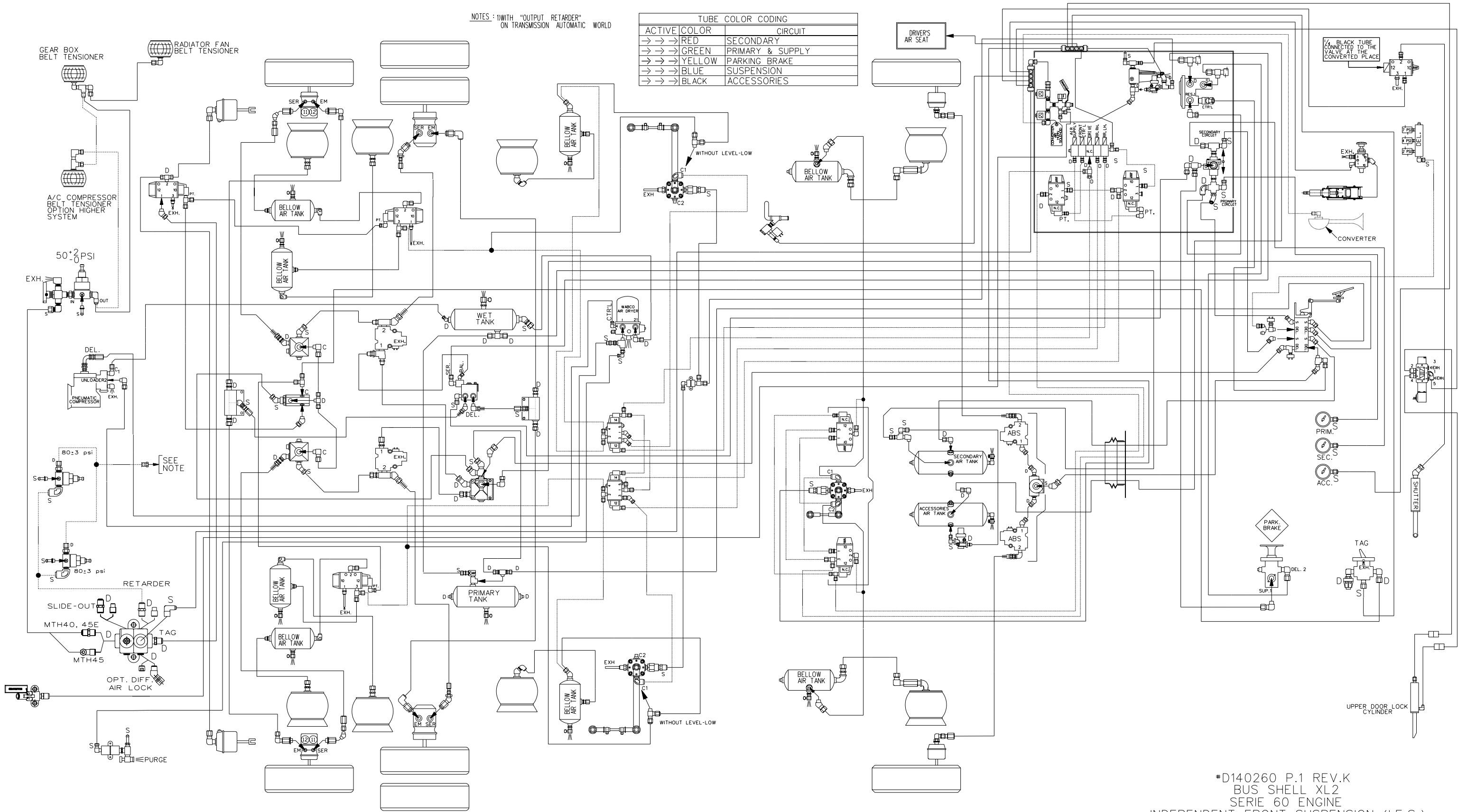

DATE: 2003-01

#D140260 P.1 REV.K
BUS SHELL XL2
SERIE 60 ENGINE
INDEPENDENT FRONT SUSPENSION (I.F.S.)

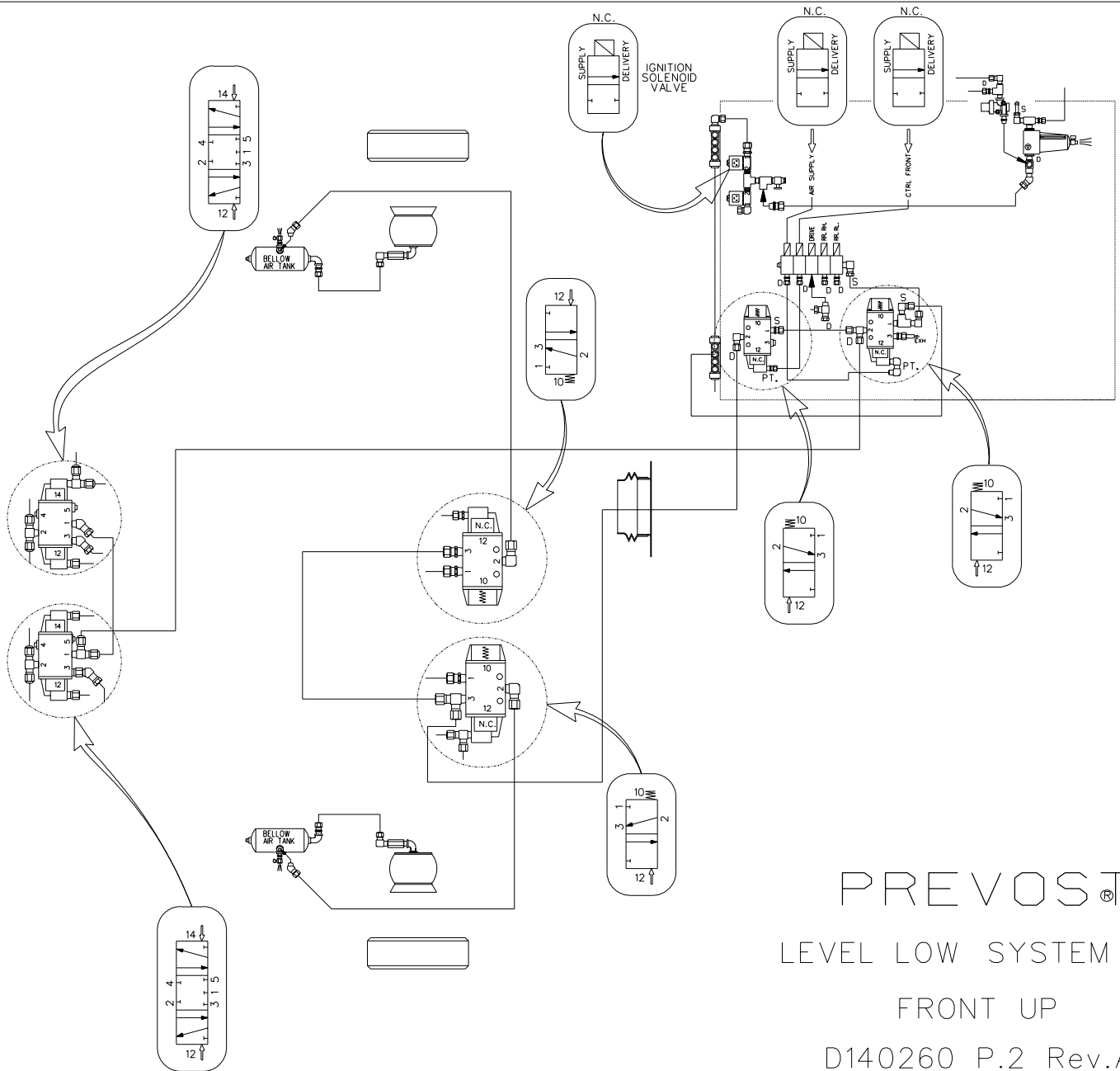
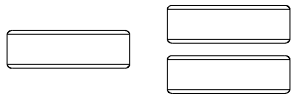
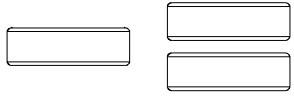

PREVOST®

LEVEL LOW SYSTEM XL2

FRONT UP

D140260 P.2 Rev.A

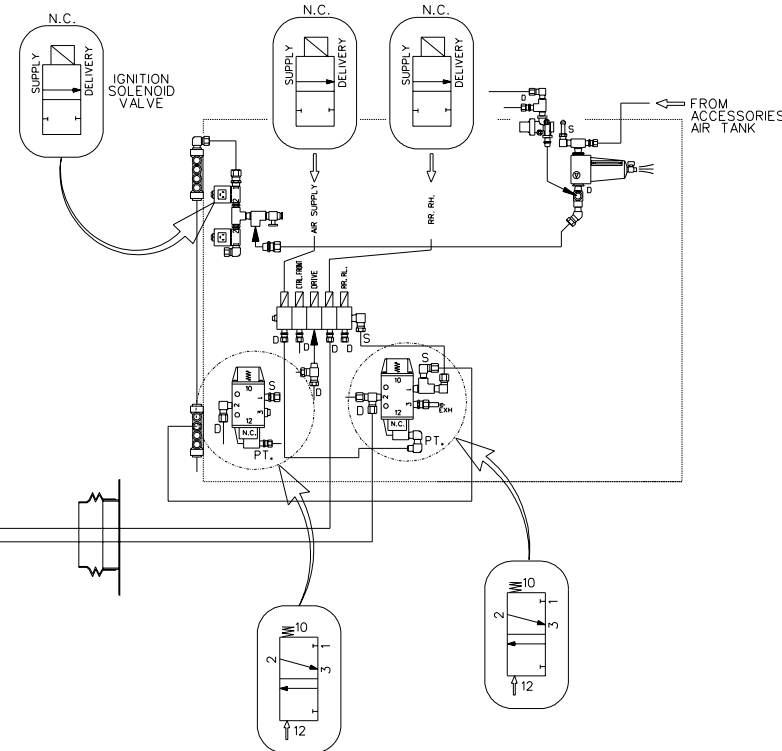
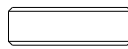
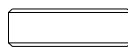
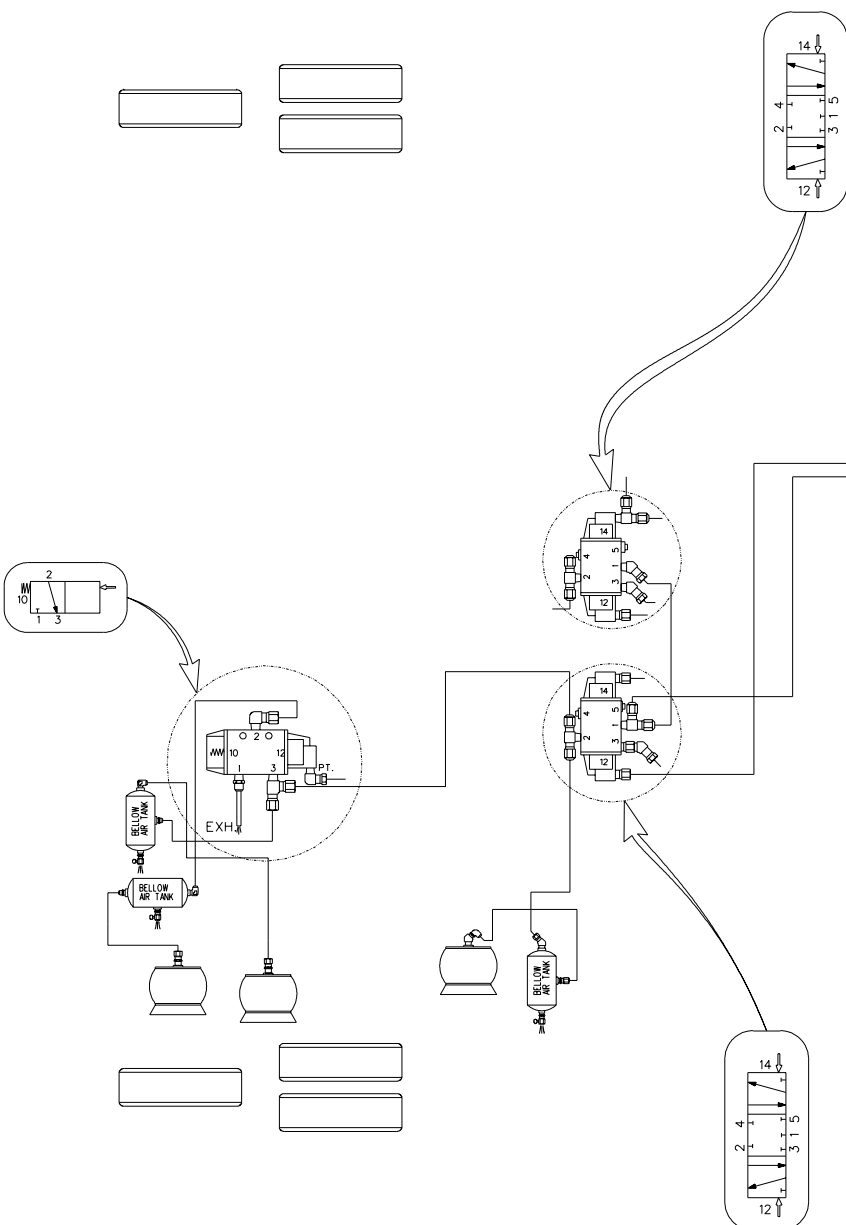

PREVOST®

LEVEL LOW SYSTEM XL2

RIGHT REAR UP

D140260 P.4