

Instruction Sheet

INSTALLATION OF A NEW SWITCH FOR THE FRONT KNEELING SYSTEM

Material

Kit #13-1165 includes the following parts.

Part no	Description	Qty
56-2130	Proximity switch	1
56-1565	Contact pin seal	5
56-1568	Male contact pin	3
56-1781	3 housing female connector	1
06-2490	Shrinkable tube 6" (15 cm)	1
13-1154	Target	1
13-1156	Support	1
50-0163	Bolt 1/4-20 x 3/4"	3
50-0473	Lock washer 1/4" I.D.	3
50-2716	Elastic stop nut 1/4-20	3
56-1689	Female contact pin	2
56-1782	3 pin male connector	1
56-1149	Terminal pin	1
56-1152	Socket terminal	1
06-3137	Wire assy 3' 3" (1 m)	1
06-3138	Wire assy 9' 10" (3 m)	1
50-4273	Cable tie 1/8" x 3 1/2" (3 mm x 89 mm)	20
FI-90124	Feuille d'instructions	1
IS-90124	Instruction sheet	1

Procedure

1. Park vehicle over a safe lifting equipment which minimum capacity must be 23,000 lbs (10 455 kg) for the drive axles, 18,000 lbs (8 200 kg) for the front axles and 10,000 lbs (4 545 kg) for the rear axle. Apply parking brake, stop engine, and set battery main disconnect switches to the "OFF" position.
2. Lift vehicle to have access to the axle. Refer to figure 1 for jacking points.

WARNING: To prevent any injury in case of lifting equipment failure, install 2 safety stands under axles 2, 3, and 5, one on each side, which minimum capacity must be 13,000 lbs (5 900 kg).

CAUTION: Never lift vehicle under axle 1 or 4, as this will damage the suspension components.

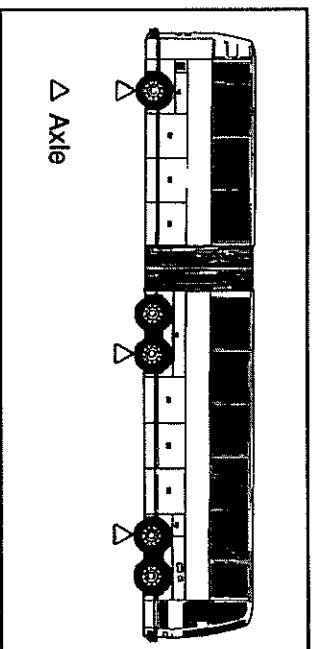

3. Locate switch installation on the cross member over axle 1 (see fig. 2).

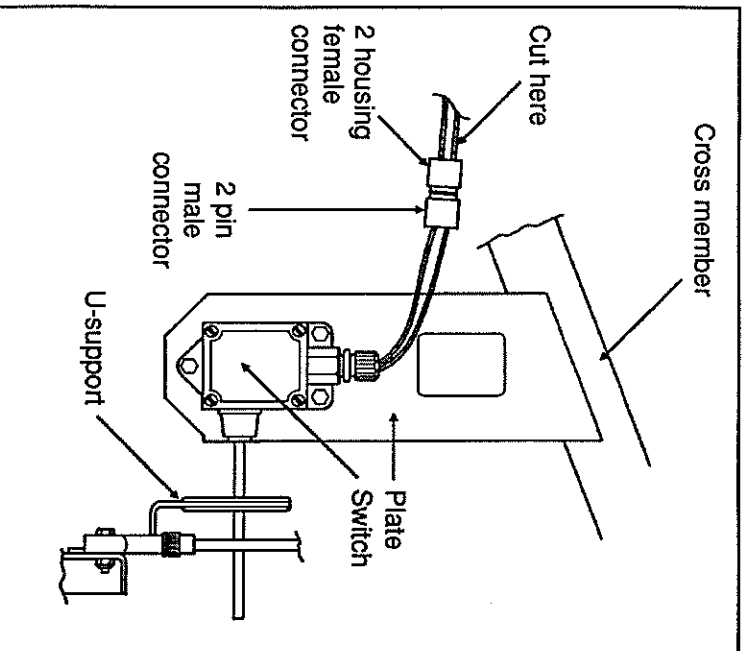

Figure 2 - Installation of the former switch

IS901242

4. Cut the two wires at the junction of the 2 housing female connector connected to the switch.
5. Unscrew the three bolts retaining the switch to the plate, remove, then discard the nuts and the switch including the male and female connectors.
6. Unscrew the two bolts retaining the U-support, discard support and bolts.
7. Slide shrinkable tube #06-2490 to the junction of the wires disconnected from switch #56-2130, then heat as required (see fig. 3).
8. Insert seal #56-1565 in the correct position on each wire (see detail A in fig. 3).
9. Fold each wire extremity, then crimp a male contact pin #56-1568 on each wire in order to grip the seal edge (see detail A).
10. Insert the contact pins in the appropriate hole of the 3 housing female connector #56-1781 according to wire color and letter code (A, B, C) of connector.
11. Using a 9/32" (7 mm) bit, drill two 9/32" (7 mm) holes on the plate mounted to the cross member, then drill a 9/32" (7 mm) hole on the moving arm according to the dimensions on figure 4.

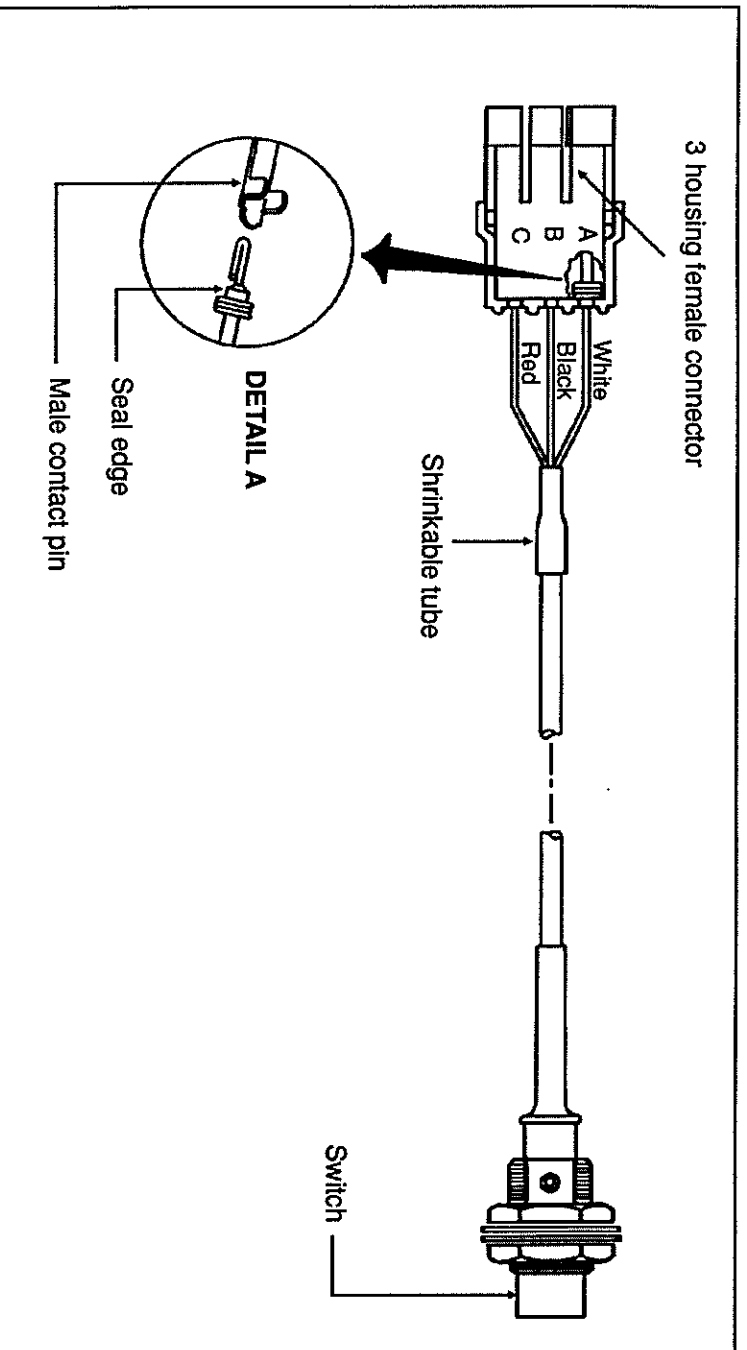

Figure 3 - Assembly of the new switch

IS901243

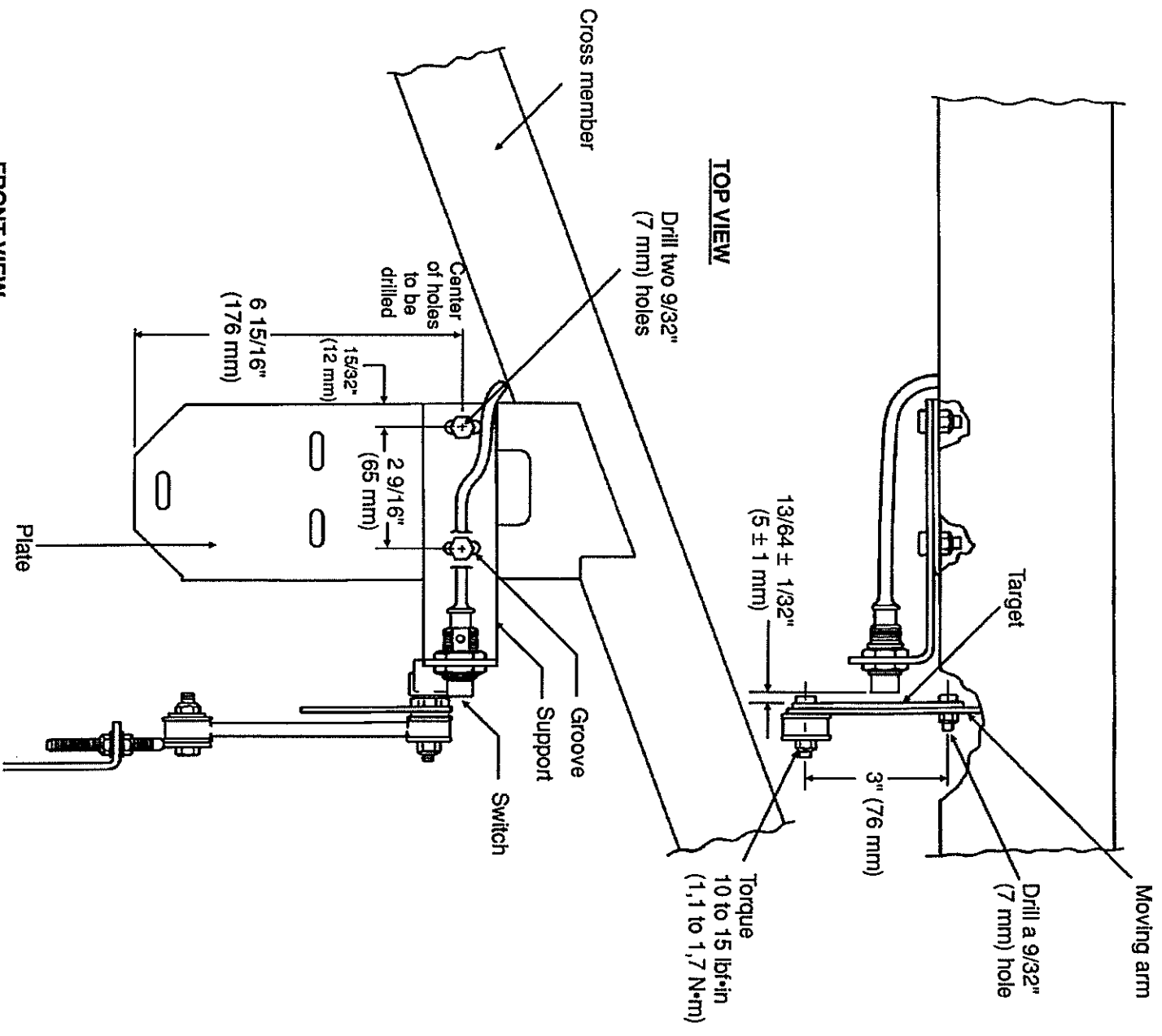

Figure 4 - Installation of the new switch

12. Install the new support #13-1156 with the two bolts #50-0163, two nuts #50-2716 and two lock washers #50-0473 on the plate mounted on cross member. Position the bolts in center of the support grooves, then tighten temporarily.
13. Install target #13-1154 on the moving arm using the existing bolt, then torque between 10 and 15 lbf·in (1,1 and 1,7 N·m).
14. Insert bolt #50-0163 in the hole previously drilled, then fix target with nut #50-2716 and lock washer #50-0473.

CAUTION: Check that nuts are installed toward the outside of arm as illustrated in figure 4, so the bolts will not touch other components.

15. Insert new switch in the support hole.
16. Install lock washers, thread in and tighten nuts on each side to allow a gap of $13/64 \pm 1/32$ " (5 ± 1 mm) between the target and the switch.

NOTE: The lock washers and nuts are supplied with the switch.

17. Strip a length of $1/2$ " (13 mm) on each wire that has been previously cut.
18. Insert the seal in the correct position on each wire.
19. Fold each extremity, then crimp the female contact pin #56-1689 on each wire in order to grip the seal edge.
20. Insert the contact pins in their appropriate hole of the 3 pin male connector #56-1782 according to wire color and the letter code on connector (see fig. 3).
21. Insert the female contact pin of 3'3" (1 m) long wire #06-3137 in male connector #56-1782 (see fig. 5).

22. Join the male and female connectors of the switch.
23. Insert this wire in the existing harness, then route it to connector C-48 located on the outer side of the back wall of the front reclining bumper compartment.
24. Unscrew connector from the wall, then insert the terminal pin #56-1149 in hole "V" of connector C-48.

NOTE: To insert a wire in this type of connector, loosen the screws of the clamping insert, unscrew the cable clamp in centre of connector, insert wire, push in terminal pin with a sharp screwdriver, then tighten assembly. The letter "V" identifying the housing is marked inside connector.

NOTE: A spare terminal pin #56-1149 has been included with the parts required for this modification, in case of breakage during the installation.

25. Fix wires with cable ties #50-4273.
26. Remove the 6 safety stands and lower vehicle.
27. Open the front reclining bumper compartment and the front electric junction box located over the front left wheels.
28. Take 9' 10" (3 m) long wire #06-3138, insert the socket terminal in housing "V" of connector C-48 located on the inner side of spare wheel compartment back wall.

NOTE: A spare socket terminal #56-1152 has been included with the parts required for this modification, in case of breakage during the installation.

29. Insert this wire in the existing harness, then route it to connector C-4 located in the front electric junction box.

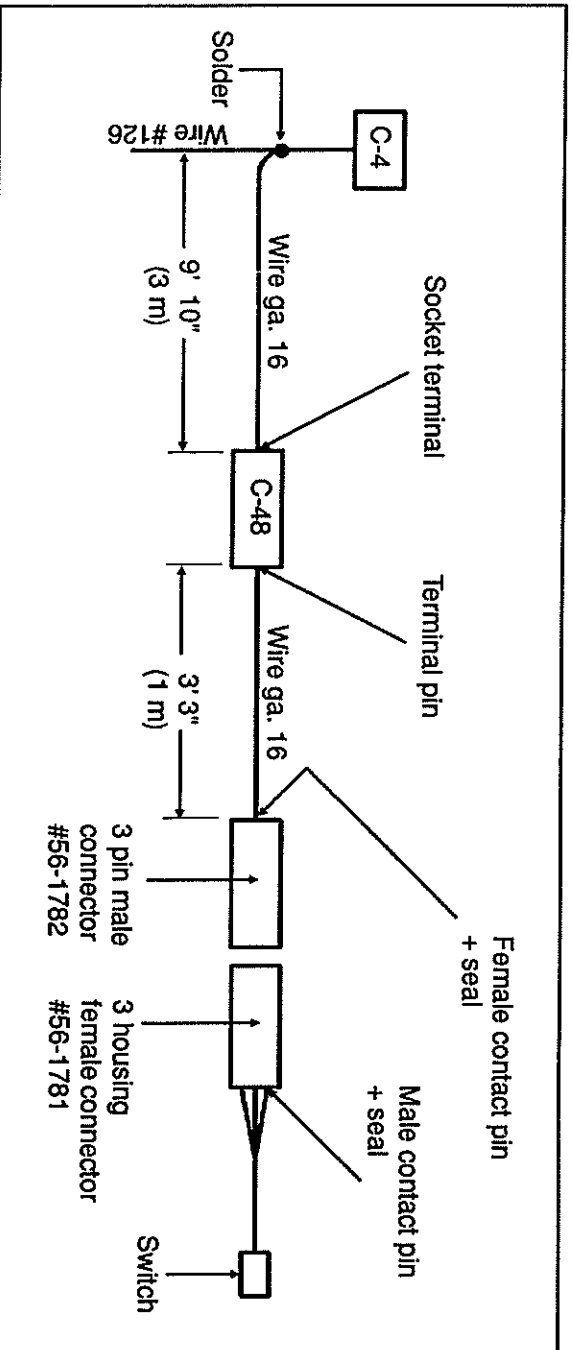

Figure 5 - Overall view of Installation

IS901245

30. Locate wire #126 in connector C-4, strip (without cutting it) the central section, then solder the extremity of the 9' 10" (3 m) long wire to this wire. Join wires together and insulate the bare wires with electric tape.

NOTE: We recommend the use of an electric soldering gun with a resin core solder combination of 60% tin and 40% lead.

31. Fix wire with cable ties #50-4273.

32. Close front reclining bumper compartment and front electric junction box.

33. Reset battery main disconnect switches to the "ON" position.

34. Turn ignition switch to the "ON" position.

35. Lift vehicle to have access to the axle while heeding to the same safety rules outlined previously.

36. Loosen the bolts of the switch support, then slide support up and down until the switch LED illuminates, if it is not already illuminated. From this position, slide support slowly down and up until LED turns out. In this precise position, tighten the bolts.

NOTE: Normally, center of switch should be slightly positioned over the target.

37. Lower vehicle and turn ignition switch to the "OFF" position.

