

PREVOST

**WARRANTY
BULLETIN**

WB17-10B

DATE :	June 2017	SECTION :	26 SLIDE-OUT
EXPIRATION:	June 2019		
SUBJECT :	SLIDE-OUT RAIL BOLT INSPECTION		

Revision : B: THIS WARRANTY BULLETIN SUPERSEDES PREVIOUS VERSION.
 2017-06-22 Warranty : added « For each inspected slide-out... »

APPLICATION

NOTICE TO SERVICE CENTERS <i>Verify vehicle eligibility by checking warranty bulletin status with SAP or via ONLINE WARRANTY SYSTEM available on Service / Warranty tab of PrevoSt website.</i>	
Model	VIN 
H3-45 VIP motorhomes Model Year : 2015 - 2017	Vehicles with PrevoSt Slide-out From 2PCVS3497 <u>FC712694</u> up to 2PCVS3493 <u>HC713747</u> incl.
X3-45 VIP motorhomes Model Year : 2015 - 2017	Vehicles with PrevoSt Slide-out From 2PCBS3495 <u>FC735779</u> up to 2PCBS3492 <u>HC736181</u> incl.
X3-45 VIP commercial use Model Year : 2015 - 2017	Vehicles with PrevoSt Slide-out From 2PCCS3491 <u>FC735749</u> up to 2PCCS3498 <u>HC736187</u> incl.
<p>This bulletin does not necessarily apply to all the above-mentioned vehicles, some vehicles may have been modified before delivery. The owners of the vehicles affected by this bulletin will be advised by a letter indicating the Vehicle Identification Number (VIN) of each vehicle concerned.</p>	

DESCRIPTION

On the vehicles affected by this bulletin, inspect and re-torque the PrevoSt slide-out rail bolts. If damaged, replace bolts.

MATERIAL

Order one kit WB17-10A per installed slide-out. Includes the following parts:

Part No.	Description	Qty
504757	FINISHING PLUG / RAIL GUIDE	12
5001617	SOCKET HEAD CAP SCREW M14-2.0x55 G10.9 DP	12

NOTE

Material can be obtained through regular channels.

TOOLS



Figure 1 : SCREW EXTRACTOR KIT (INCLUDING M14 SIZE)



Figure 2 : Centering punch and drill

PROCEDURE



DANGER

Park vehicle safely, apply parking brake, stop engine. Prior to working on the vehicle, set the ignition switch to the OFF position and trip the main circuit breakers equipped with a trip button. On the Commuter type vehicles, set the battery master switch (master cut-out) to the OFF position.

This procedure should be carried out by technicians familiar with slide-out operation.

1. Extend the slide-out room.
2. Set the ignition switch to the OFF position and trip the main circuit breakers equipped with a trip button.
3. From under the slide-out, locate the slide out rail socket head screws. (Fig. 3)
4. Remove the protecting cap.

Take care not to damage the rail edge or surface.

5. Re-torque to **90-100 lb-ft (122-136 Nm)**.

Perform this only on accessible rail screws.

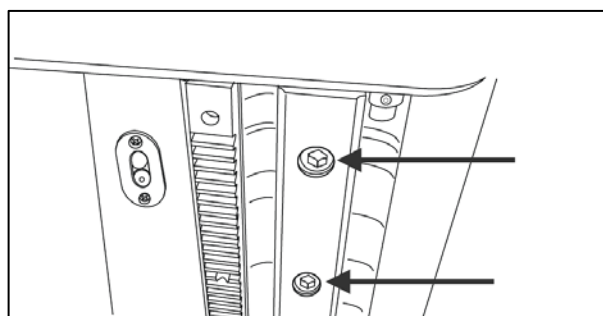

Figure 3

6. If the screw head is broken, use a bolt extractor kit to remove the bolt. Closely follow kit instructions.
7. Replace with a new 5001617 screw (Fig. 4). Tighten to **90-100 lb-ft (122-136 Nm)**.

Note that kit WB17-10 includes additional screws for a replacement of visible screws on the longest slide out configuration.
8. Replace any missing or damaged finishing plugs with replacement plugs #504757 supplied in the kit.(Fig. 4)
9. Finishing plug should be mounted flush with rail surface to avoid inflatable seal damage.
10. Set breakers and ignition switch back on.
11. Confirm proper slide operation.

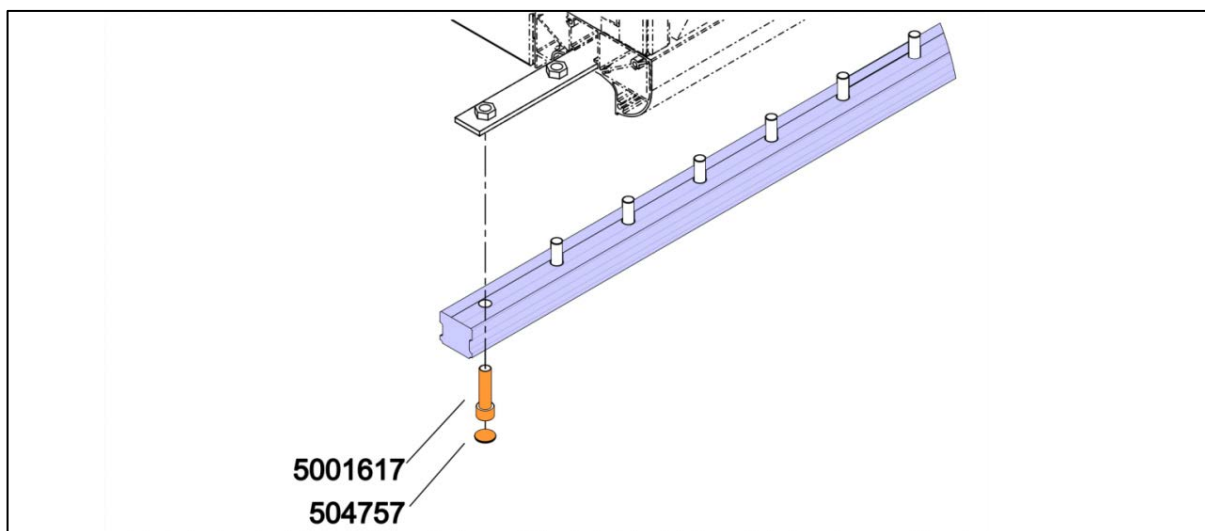

Figure 4

PARTS / WASTE DISPOSAL

All replaced parts must be returned to Prevest according to the Return Shipping Instructions available on <https://www.prevestcar.com/content/warranty-documents> for full reimbursement. A copy of the warranty claim form must be enclosed with the shipment.

Discard waste according to applicable environmental regulations (Municipal/State[Prov.]/ Federal)

WARRANTY

This modification is covered by Prevest's normal warranty. For each inspected slide-out, we will reimburse you fifteen minutes (15min) of labor for re-torquing without bolt replacement or one hour (1h) of labor plus replaced parts upon receipt of a warranty claim. Please submit claim via our Online Warranty System, available at www.prevestcar.com (under Service \ Warranty section). Use Claim Type: "Bulletin/Recall" and select "Warranty Bulletin WB17-10".

OTHER

VBC Bulletin	N/A
Fail Code	26.03
Defect Code	09
Syst. Cond	B
Causal Part	5001617

Access all our Service Bulletins on
<http://techpub.prevostcar.com/en/>
or scan the QR-Code with your smart phone.
E-mail us at **technicalpublications_prev@volvo.com** and
type "ADD" in the subject to receive our warranty bulletins by e-
mail.

