

Instruction Sheet

SEALING TECHNIQUE FOR EMERGENCY EXIT SIDE WINDOWS AND ALUMINUM EXTRUSIONS

Material

Part no	Description	Qty
29-1132	Window rubber strip	7 (8 for 96")
50-6243	Rubber shim	7 (8 for 96")
50-4120	Aluminum rivets 3/16" x 1/2"	AR
68-0747	"Tremthane" sealant 10 oz (300 ml)	AR
68-0096	Butyl sealant 10 oz (300 ml)	AR
68-0089	Silicone 10 oz (300 ml)	AR
68-0029	All-purpose cement 1 gal (4 l)	1
IS-9119A	Instruction Sheet	1

NOTE: Material can be ordered through regular channels.

Procedure

1. Park vehicle, apply parking brake, stop engine and set battery main disconnect switch(es) to the "OFF" position.

NOTE: We strongly recommend the installation of scaffolds along both sides of vehicle to perform this procedure.

2. Disengage hook carefully, then slide out vinyl molding from the aluminum extrusions on top of side windows.

NOTE: Before removing the vinyl molding, make sure that molding is at the ambient temperature.

NOTE: Take care not to damage molding during removal.

3. If required, clean the heads of the rivets retaining the aluminum extrusions and remove rivets if necessary.

NOTE: Use a 1/8" (3 mm) punch and a hammer to drive out rivet, then drill rivet center with a 11/64" (4 mm) bit.

CAUTION: Drill bit must not exceed more than 2" (5 cm) the drill chuck.

- Remove all stains and corrosion on the aluminum extrusions, then clean inside of extrusions where the molding slides.
- Apply a coat of "Tremthane" on the rivets. See figure 1.

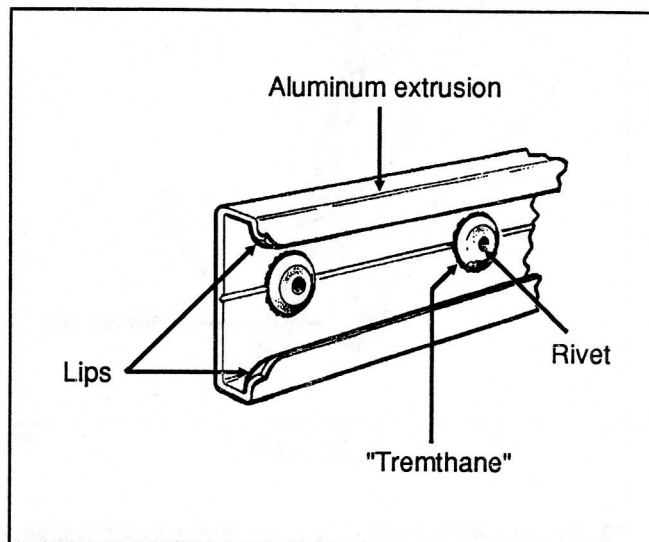

Figure 1

IS911901

6. Insert all rivets in the extrusions and turn rivets one turn to ensure an uniform application of the "Tremthane".

NOTE: Check that there is enough "Tremthane" around the rivet heads.

7. Rivet the extrusions to the structure.

8. Fill up all other holes on the aluminum extrusions with "Tremthane".

9. Seal the top joint of the extrusions with "Tremthane".

10. Inspect extrusions, then seal holes or cracks with "Tremthane" if required.

11. Clean bottom of extrusions.

12. From inside vehicle, lift aluminum release bar and push bottom of window to open each of the 7 (8 on 96" vehicles) emergency exit side windows. See figure 2.

NOTE: There are 3 emergency exits on the R.H. side and 4 on the L.H. side for the «XL» vehicles; as for the 96" vehicles, there are 4 emergency exits on each side.

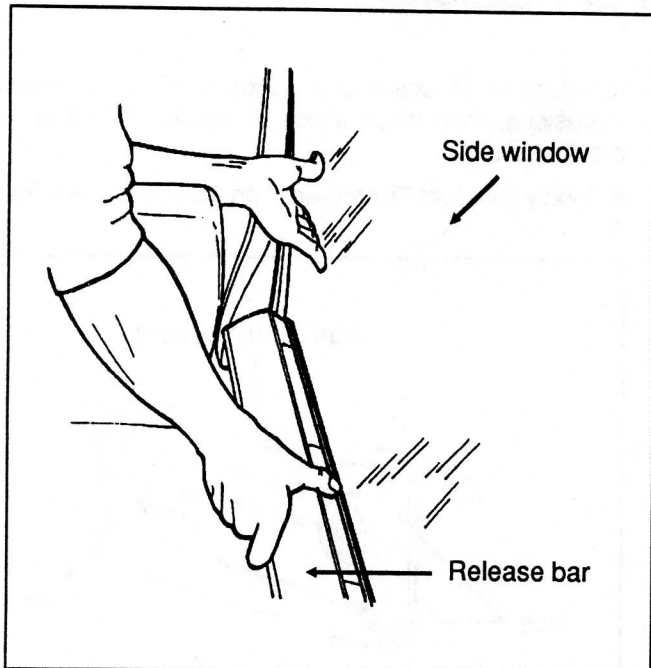

Figure 2

IS911902

13. Open each emergency exit window to the horizontal position, and support it with a beam or an aluminum rod.

CAUTION: Do not open windows to an angle exceeding 80°.

CAUTION: Do not support window by the glass.

14. Remove the rubber strip on the outline of each emergency exit window. See figure 3.

15. Clean frame with a steel brush fixed to a drill which maximum speed must be 1000 rpm. See figure 4.

WARNING: Wear safety goggles and gloves.

CAUTION: Take care not to pierce fiberglass.

16. Apply cement on rubber strip, on each side of drain, on frame surface, as well as on the bottom and top sections of frame, then allow cement to dry during 5 minutes. See figure 4.

NOTE: Do not apply cement in drain.

17. Affix rubber strip to frame.

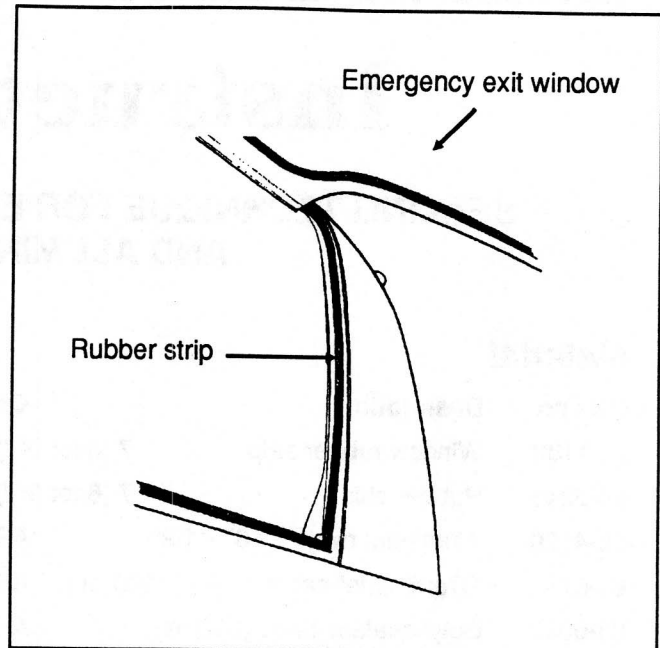

Figure 3

IS911903

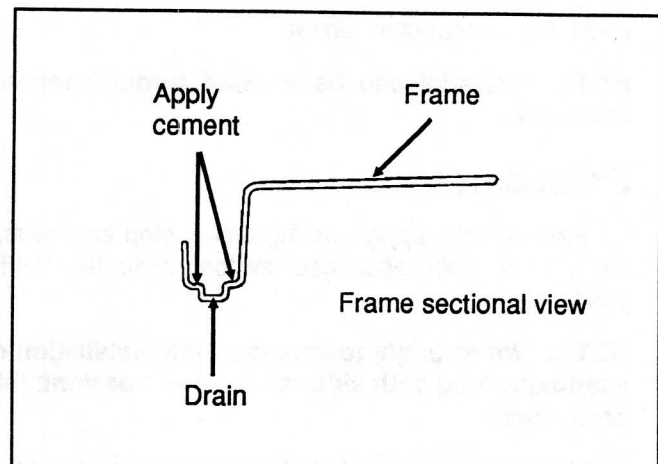

Figure 4

IS911904

18. Apply cement in bottom of the frame top section.

CAUTION: Make sure there is no accumulation of cement on top of frame.

19. Apply cement to the underside of the rubber spacer, then allow cement to dry during 5 minutes.

20. Affix the rubber spacer on the rubber strip located on top of frame.

21. Remove beam or aluminum rod, then close and lock the windows.

CAUTION: Allow half an hour before closing windows.

22. Make a butyl joint in the two upper corners of the emergency escape window frame to fill the cavities.

23. Using a screwdriver, spread lightly each rear lip of the aluminum extrusions to ease sliding of vinyl moldings. See figure 1.

24. Cut the inside lips of the vinyl molding to an angle. See figure 5.

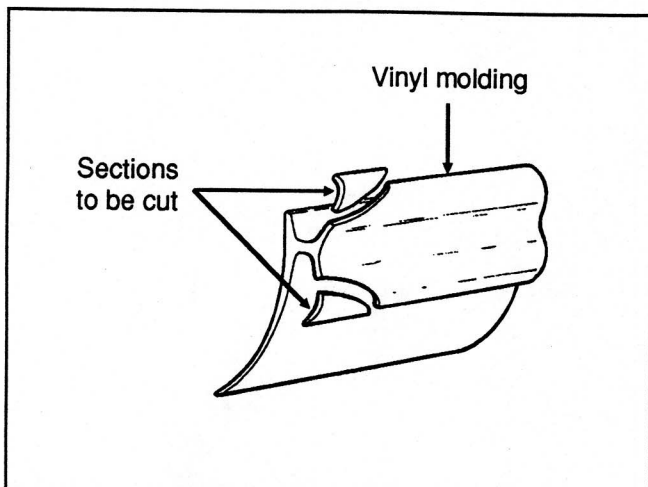

Figure 5

IS911905

25. Clean vinyl moldings with a solvent.

26. Lubricate by spraying silicone on the aluminum extrusions and the vinyl moldings.

27. Slide the vinyl moldings in the aluminum extrusions and fix the hooks to each extremity.

28. Lift vinyl molding, drill three drip holes with a #11 bit towards the centre of the fixed windows, then replace molding. See figure 6.

29. Perform a butyl joint on the aluminum extrusion. See figure 6.

30. Reset battery main disconnect switch(es) to the "ON" position.

CAUTION: When vehicle is parked overnight or for an extended period of time, the battery main disconnect switch(es) should be set to the "OFF" position.

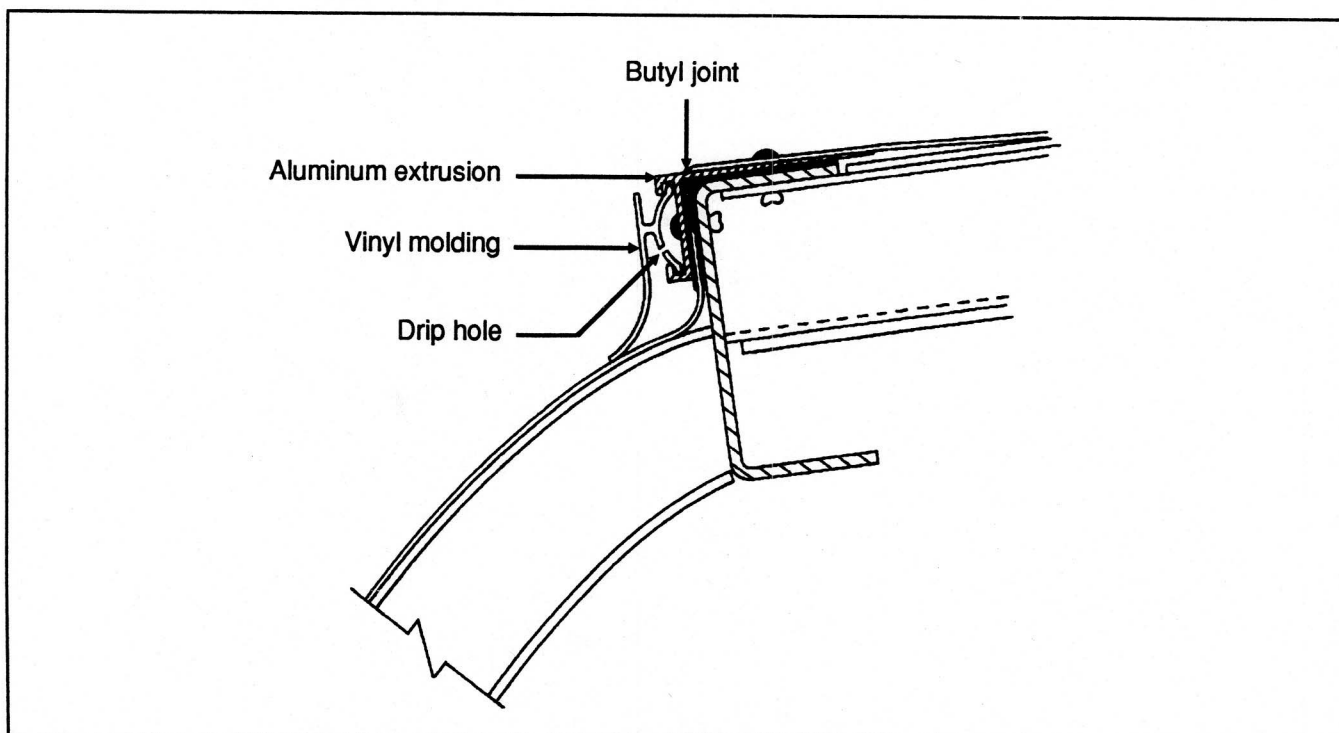

Figure 6

IS911906