

Instruction Sheet

H3-40 TOUR GUIDE SEAT KIT

Material

Kit #36-3029 includes all parts listed below. Refer to figures 1 and 2.

Item	Part no	Description	Qty
	10	36-3071 Bolt assembly 3/8" x 2 1/2"	1
1	36-3042	Seat assembly	1
	11	50-4314 Rivet 1/4" (6 mm) S.S.	6
2	36-3063	Seat support	1
	12	36-3070 Bolt assembly 3/8" x 4"	1
3	36-3069	Finishing cap	1
	13	50-01024 Screw 1/4-20 x 2"	4
4	36-3078	Aluminum plate	1
	14	50-0473 Lock washer 1/4" (6 mm)	4
5	36-3030	Anchor plate	2
	15	50-0444 Flat washer 3/8" (10 mm)	2
6	36-2923	Plate assembly	1
	16	36-3077 Cushioned trim (fig. 2)	1
7	50-4105	Rivet 1/8" (3 mm)	4
		36-3072 Wood spacer (not shown)	1
8	50-0345	Finishing washer	2
		IS-91060 Instruction Sheet	1
9	50-0686	Screw #6 x 1/2"	2
		FI-91060 Feuille d'instructions	1

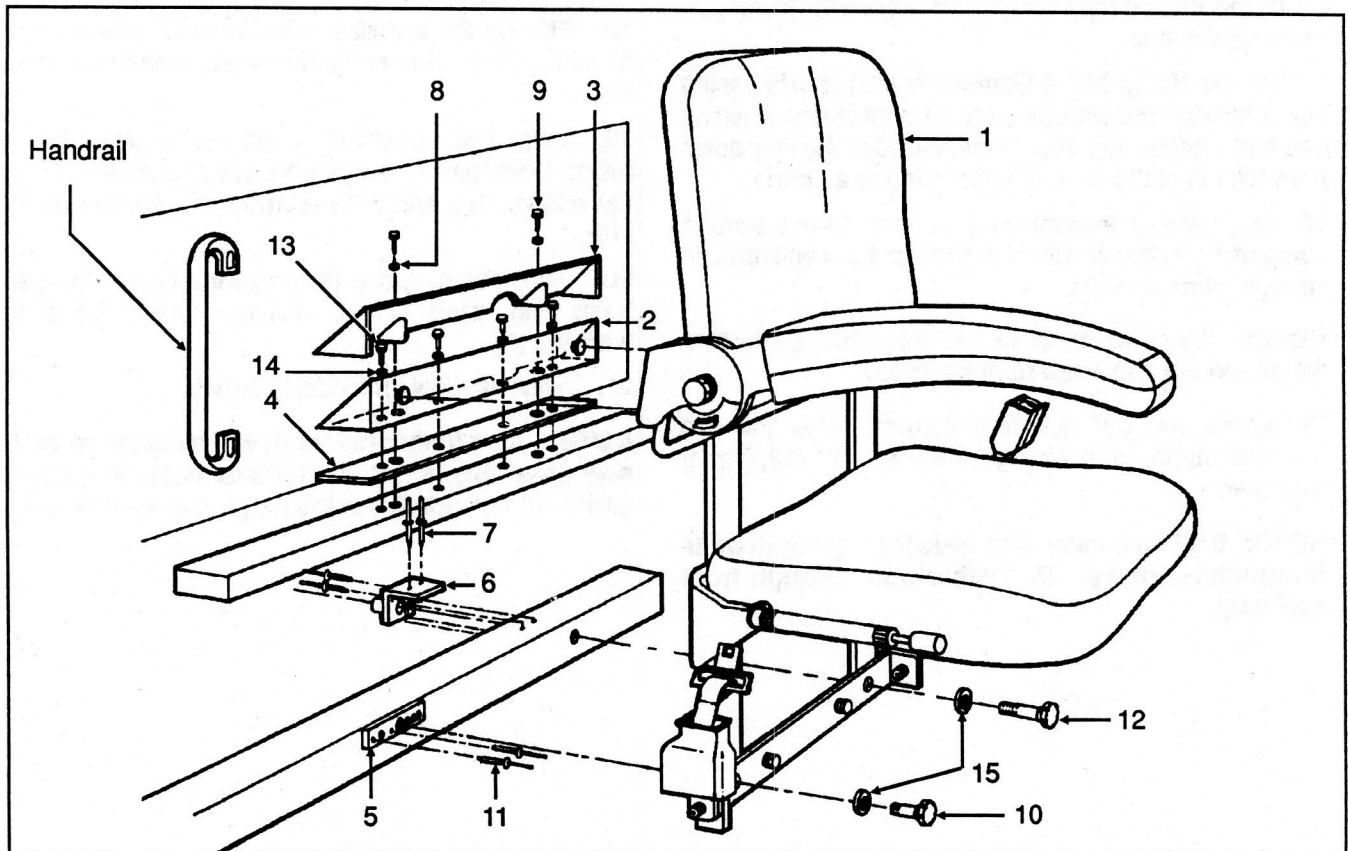

Figure 1

IE912801

Procedure

1. Park vehicle, apply parking brake, stop engine and set battery main disconnect switches to the "OFF" position.
 2. Remove handrail from R.H. modesty panel.
 3. Remove stainless steel moulding on the front edge of the passenger level floor.
 4. Insert the piece of wood included in the kit between the end of the floor surface and the stepwell wall to provide a solid base for seat support (2). Reinstall stainless steel moulding.
 5. Drill four 1/4" (6,4 mm) diameter holes through aluminum plate (4), matching the holes in seat support (2).
 6. Position aluminum plate (4) and seat support (2) on the passenger level floor with the bottom edge of the seat support flush with the stepwell wall and its cut-out area clearing the modesty panel tubing.
 7. Align holes in aluminum plate (4) and seat support (2), then drill four 7/32" (5,5 mm) diameter holes through floor. Fasten seat support and aluminum plate with 4 self-tapping screws (13) and 4 lock washers (14).
 8. Install seat assembly (1) firmly on seat support (2) and locate the left and right fastening points on the lower part of the seat frame.
 9. Drill one 1/8" (3,2 mm) diameter hole at both fastening points through the storage compartment plastic finishing cap and steel tubing, approximately 1/3 of the way down from the top of the slotted holes in the seat frame.
 10. Remove seat assembly (1), remove driver's storage compartment door and finishing cap, pull out and remove storage compartment.
- NOTE: Mark location of the door hinges before removing door to ease reinstallation.**
11. Locate the 1/8" (3,2 mm) diameter holes drilled in the steel tubing and enlarge them to 1/2" (12,7 mm) diameter.

NOTE: Drill hole nearest to aisle through both walls of structure tubing. Drill other hole through front wall only.

12. Remove a section of the fiberglass trim to make room for the anchor plate (5). Align threaded hole in anchor plate with hole in tubing.

NOTE: Top of anchor plate (5) must not exceed top of tubing when both holes are aligned. Also, weld beads on the tubing may have to be removed to install anchor plate correctly.

13. Drill six 1/4" (6,4 mm) diameter holes and fasten anchor plate (5) with 6 stainless steel rivets (11), 3 on each side of threaded center hole and on the same axis as the center hole.

CAUTION: Follow the above instructions carefully. Use the rivets provided in the kit only. Other rivets may be of inadequate strength and quality.

14. Install plate assembly (6) behind L.H. holes in tubing and insert bolt (12) to hold the plate firmly.
15. Drill two 1/8" (3,2 mm) diameter holes and fasten back side of plate assembly (6) with 2 rivets (7).
16. Fold plate assembly (6) on top side of tubing, drill two 1/8" (3,2 mm) diameter holes and fasten plate on top side of tubing with 2 rivets (7). Remove screw.
17. Install driver's storage compartment, finishing cap, and compartment door.
18. Enlarge the 2 drilled holes in the finishing cap to allow insertion of bolts holding seat frame to stepwell wall.
19. Install seat assembly (1) on seat support (2) and fasten lower part of frame with bolt assembly (10) and flat washer (15), and bolt assembly (12) and flat washer (15).
20. Place finishing cap (3) on seat support (2), drill 2 holes and fasten with 2 finishing screws (9) and 2 washers (8).
21. Install handrail on modesty panel.

NOTE: Install handrail vertically to allow room for seat assembly (1). Cover leftover holes in modesty panel with plastic finishing plugs obtained locally.

22. Place cushioned trim (16) on handrail in front of the seat. See figure 2.

WARNING: Always wear seat belt and make sure the cushioned trim is correctly positioned on the handrail to prevent serious injury in case of a sudden stop or impact.

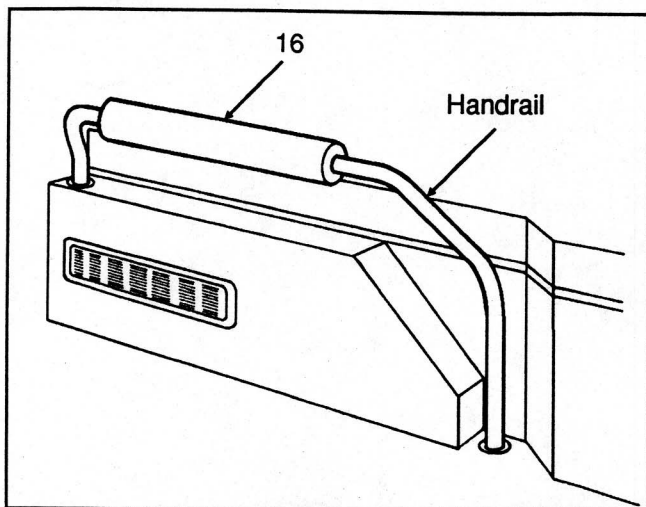

Figure 2

IE912802

23. Reset battery main disconnect switch(es) to the "ON" position.

CAUTION: When vehicle is parked overnight or for an extended period of time, the battery main disconnect switches should be set to the "OFF" position.