

Instruction Sheet

LAVATORY VENTILATOR ASSEMBLY

Application: Model: "XL" coaches

VINs: 2P9L33406E1001638 to 2P9L3340XP1001581 inclusively

Description

To insure reliable operation of lavatory ventilation system, a more efficient ventilator assembly has been introduced, and supersedes previous model used on the above-mentioned vehicles. To install the latter, proceed as follows:

Material

Part no	Description	Qty
40-3611	Ventilator assembly	1
50-0277	Rivet nut 5/16-18 x 3/4"	3
50-0179	Hex. head screw 5/16-18 x 3/4"	3
50-0611	Self-tapping screw 10-24 x 1/2"	1
50-0641	Self-tapping screw #8 x 3/4"	1
50-4012	Locking tie	2

Procedure

WARNING: Park vehicle, apply parking brake, stop engine and set battery master switch to the "OFF" position prior to working on the vehicle.

1. Remove the existing lavatory ventilator assembly.
 - a) Locate ventilator assembly in the upper section of engine compartment when opening the R.H. side rear door (Fig. 1).
 - b) Disconnect ventilator motor electric wires.
 - c) Dismount ventilator assembly from vehicle.
 - d) Remove hose clamp and disconnect air hose from ventilator.

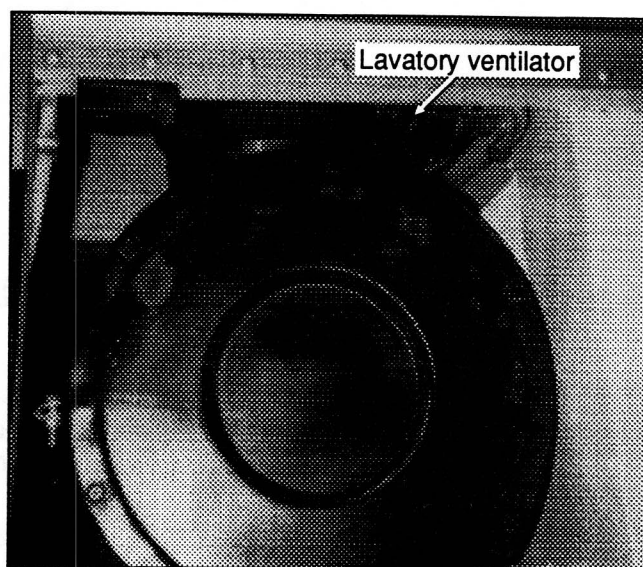

IS920351

Fig. 1 - Lavatory Ventilator Setup (previous model)

2. Reposition engine coolant temperature gauge in compartment to make room for new ventilator setup.
 - a) Locate temperature gauge in the upper section of engine compartment when opening the R.H. side rear door.
 - b) Dismount temperature gauge assembly from vehicle.
 - c) Position the assembly as shown in figure 4, then using holes in support as guides, mark new location of mounting holes on front panel. Punch the center, then drill two 0.136" (3,5 mm) dia. holes (bit #29).
 - d) Put the assembly into position, and secure with the two previously removed #8 x 3/4" self-tapping screws.

3. Install three 5/16-18 x 3/4" rivet nuts for mounting of new ventilator assembly on engine air filter intake duct.

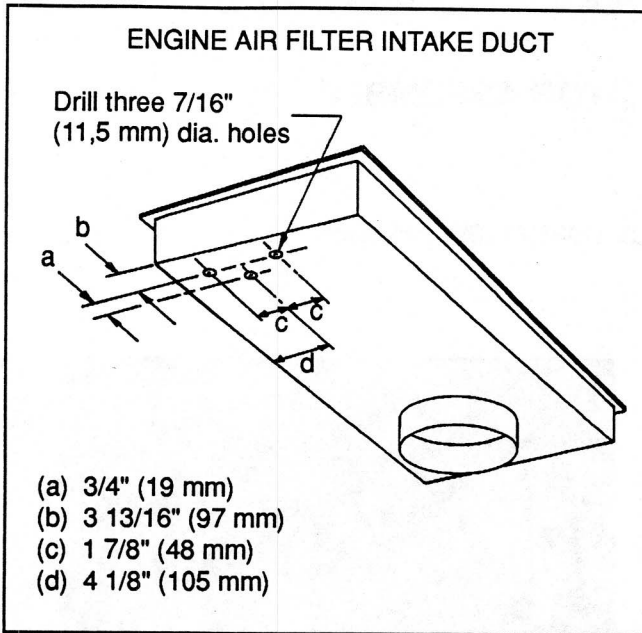

Fig. 2 - Ventilator Mounting Holes

- a) Using an appropriate tracing tool, mark location of mounting holes on engine air filter intake duct (Fig. 2). Punch the center, then drill three 7/16" (11,5 mm) dia. holes.
- b) Using a wrench-type header tool (SPAE-NAUR No. T-722-5/16-18 - Fig. 3), install a 5/16-18 x 3/4" rivet nut into each mounting hole. Upon actuation of tool, the shank of the rivet nut will expand tightly against panel.

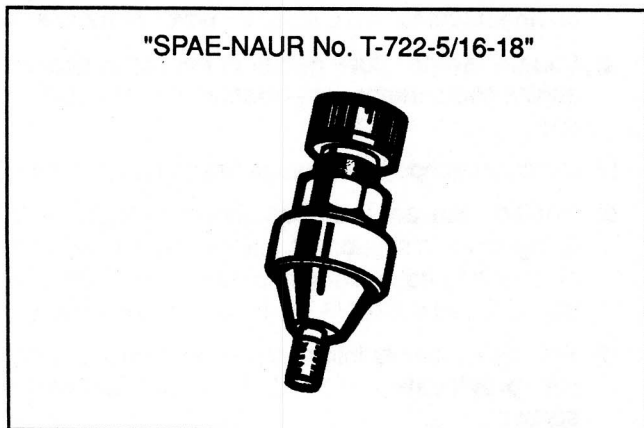

Fig. 3 - Wrench-type Header Tool

NOTE: If the special tool is not available, a wrench can be made to prevent rivet nut from rotating while installing it; drill a 21/64" (8,3 mm) dia. hole at the end of a 14 gauge steel plate about 3/4" x 8" (20 x 200 mm). Simply put a 5/16-18 x 1" gr. 8 screw through the hole in wrench and then into rivet nut, insert into mounting hole in duct, hold wrench and run in screw.

4. Install new ventilator assembly.

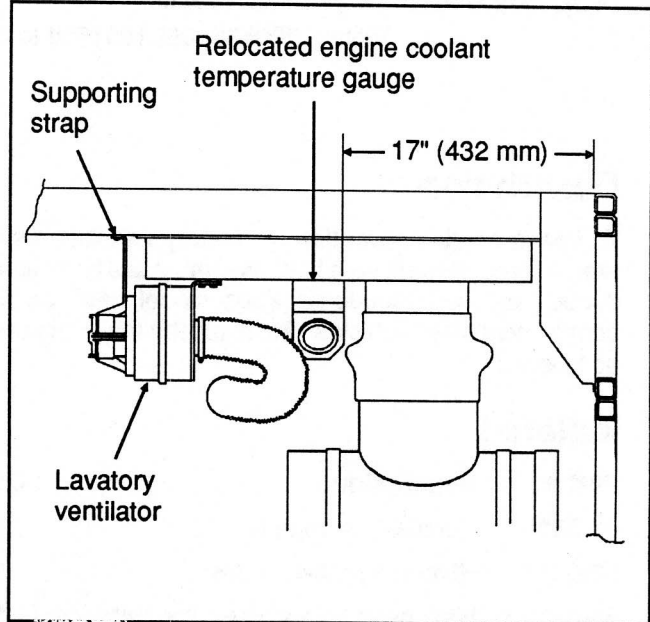

Fig. 4 - Lavatory Ventilator Setup (new model)

- a) Put the ventilator assembly into position (Fig. 4), and secure with three 5/16-18 x 3/4" hexagonal head screws.
 - b) Using the hole in ventilator supporting strap as a guide, drill a 5/32" (4 mm) dia. hole in upper panel. Fasten with a 10-24 x 1/2" self-tapping screw.
5. Connect air hose and secure with the previously removed hose clamp.
 6. Connect ventilator electric wires.
 - a) Make a punch mark about 2" (50 mm) above ventilator air tube passage in front panel, then drill a 0.136" (3,5 mm) dia. hole (bit #29). Fasten ventilator ground wire (black) to front panel with a #8 x 3/4" self-tapping screw.
 - b) Connect the remaining wire (green) to the same electric lead which was used with former ventilator assembly. Attach the exceeding length of electric lead to the wiring harness from which it is issued.