

# PREVOST

## Instruction Sheet

## IS-20007A

### DRIVER'S AIR CONDENSER REPLACEMENT AND RELOCATION













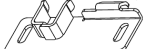

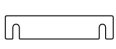

X3-45VIP FROM E-5459 TO H-6179 RETROFITTED WITH EFD



















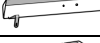



Revision: A Material: Added hardware.























November 2020

### MATERIAL

Kit #IS20007 includes the following parts:

Part No.	Description		Qty
<b>Compressor Door Parts (Steps A-B-C)</b>			
030082	SHIM U 3.175MM		3
280504	DOOR UPPER HINGE		1
280549	DOOR UPPER HINGE		1
280567	COMPRESSOR DOOR CATCH PIN		1
280589	ROLLER		1
280599	SHIM		2
280610	SHIM		1
284607	NYLON BUSHING		2
430406	WASHER		3
502570	WSH LO SPT SS 6.1X11.8X1.6 (M6,#12)		3
502622	SCR CAP HEX SS NSS M6X20 FT		2
502723	WSH FL NYL .386X.750X.050 (M8,3/8)		1
502854	NUT HEX N500 M6-1		3
2810294	HINGE DOWN COMP. DOOR ASSY		1
5000310	SCR CAP HEX SS NSS M6X1 X 40		2
5001063	NUT RIV FL OKS M8-1.25X11X1.5		2
5001461	SCR MA FL PH SS M8-1.25X40 FT		1
5001815	SCR CAP HEXF N500 M6-1 X 30 G 8.8		3

Part No.	Description		Qty
5001833	WSH BEL SPR SS 301 6.65X17.4X1.27(M6,1/4		4
5001868	WSH BELL SS 8.4X18X2 (M8,5/16)		2
5001912	SCR CAP HEX SS NSS M8X30		2
5001983	NUT HEX NYRT SS NSS M8X1.25		5
7770484	PLATE SS 304 3"X3" 11GA		1
<b>Condenser Relocation Parts (Steps D to K)</b>			
454030	HOSE ASS 1550 MM LG		1
454031	HOSE, CONDENSER 2570 MM LG, ASS		1
454032	HOSE CONDENSOR 3180MM LG ASS		1
454033	HOSE ASS 800 MM LG		1
454035	SUPPORT, FILTER DRYER		1
454036	FAN PROTECTOR PANEL (GUARD)		1
454037	SHROUD ASSEMBLY		1
454156	SUPPORT CONDENSER ASSEMBLY		1
500107	SCR TC HEX Z050 1/4-20X2 1/2		2
500411	WASHER FL .260x.697x.050 SS		6
500607	SCR MA TR PH SS 10-24X1		3
501338	TEE 1/4PM X 1/4PF X 1/4PF		1
502655	SCREW CAP HEX M10-1.5x25 SS BK		1
502780	SCR CAP HEX SS NSS M8X25		2
502853	WASHER LO SPT 6.1x11.8x1.6 N500		6
504016	CABLE TIE, NYLON BLK (LIGHT-HEAVY)	-	4
504357	WSH FL SS .187X.437X.050 (M4,#8)		3
504637	CABLE TIE, NYLON BLK (STD)	-	30
504727	CLAMP HOSE POLY 2 BLOCKS FOR 2 HOSES		2
504728	COVER, PLATE T3		2
504751	DUAL SWIVEL SADDLE SPACER (100 POUNDS)		1

Part No.	Description		Qty
506228	TAPE RUB ADH1 CC POL 1/4" x 1/2" x 37.5' / GREY 2520X		90"
561565	WIRE SEAL PED W-PACK 20-16 GRN		2
561566	CONN PED W-PACK 2 PH		1
561567	TERM PED WEATHER-P PIN 20-18AWG		2
563332	MINI RELAY, 24V WITH RESISTOR		2
565881	FAN CONDENSOR 12" - BRUSHLESS - AXIAL		1
0610379	HARNESS, DRIVER AIR CONDENSER X3	-	1
950249	VALVE SCHRAEDER		1
950270	PRESSURE SWITCH		1
950552	CONDENSOR		1
952629	CLAMP P STL ZP RUB 15.9 ID		6
952634	CLAMP P STL ZP RUB 23.8 ID		2
5001137	WSH FL SS .203X.438X.06 (M5,#10)		24
5001180	NUT HEX NYRT SS 10-24		6
5001241	SCR MA TR PH SS 10-24X1/2		3
5001448	WSH FL SS .343X.875X.040 (M8,5/16)		10
5001697	SCREW CAP HEX M6-1.0x16 SS BK		6
5001758	NUT HEX STO M10-1.5 N500		1
5001787	NUT HEX NYRT SS M8-1.25X9.5		6
5001851	NUT HEX M6-1.0 SS BK		4
5001912	SCR CAP HEX SS NSS M8X30		6
5001975	SCR TC BDG PH SS410 Z050 10-24X3/8		24
5001981	HEX CAP SCR SS NSS M8X50		2
5001983	NUT HEX NYRT SS		6
8079360	CABLE TIE		3
N37749	DUAL CLAMP TIE		8
IS-20007	Instruction sheet	-	1
FI-20007	Feuille instruction	-	1

<b><i>NOTE</i></b>
<i>Material can be obtained through regular channels.</i>

## Table of Contents

A. COMPRESSOR DOOR UPPER HINGE REPLACEMENT .....	5
B. ROLLER SUPPORT ADDITION ON COMPRESSOR DOOR.....	8
C. COMPRESSOR DOOR LOWER HINGE REPLACEMENT .....	10
D. CONDENSER RELOCATION OVERVIEW .....	19
E. CONDENSER RELOCATION AND PREPARATION .....	20
F. CONDENSER INSTALLATION.....	21
G. A/C HOSE INSTALLATION .....	22
H. FILTER DRYER INSTALLATION.....	23
I. PRESSURE SWITCH INSTALLATION .....	24
J. WIRING HARNESS INSTALLATION.....	25
K. VPG: PARAMETER SETTING.....	26

## PROCEDURE



### DANGER

Park vehicle safely, apply parking brake, stop engine. Prior to working on the vehicle, set the ignition switch to the OFF position and trip the main circuit breakers equipped with a trip button. On Commuter type vehicles, set the battery master switch (master cut-out) to the OFF position.

Lock out & Tag out (LOTO) must be performed during set-up, maintenance or repair activities. Refer to your local procedure for detailed information regarding the control of hazardous energy.

## A. COMPRESSOR DOOR UPPER HINGE REPLACEMENT

1. Fully open the vehicle compressor door (rear, curb side of vehicle Figure 1).

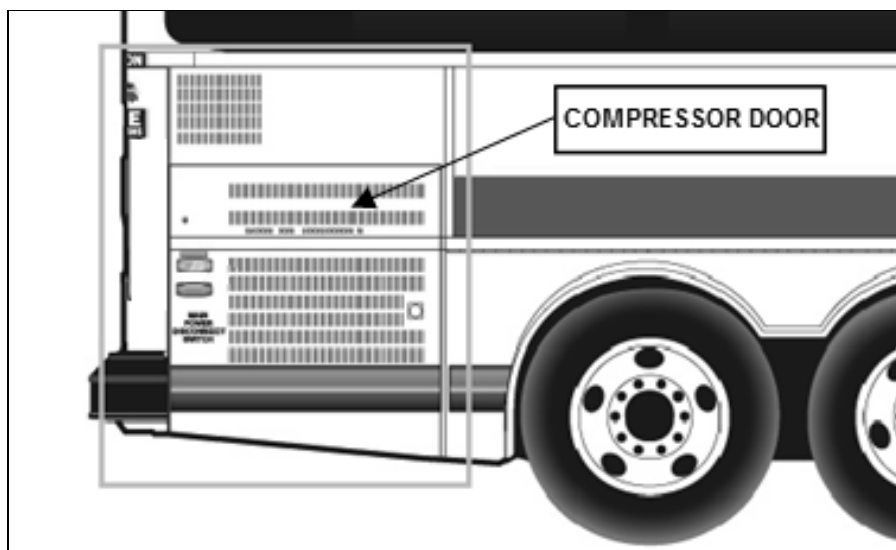

FIGURE 1: VEHICLE COMPRESSOR DOOR

2. Support the door at its lower edge without applying upward pressure. A scissor jack (or equivalent lifting equipment) and a V shaped wood block are recommended (Figure 2).



FIGURE 2: SUPPORTING THE DOOR

3. Unscrew and remove both parts of the upper hinge (4X M6 bolts at frame and door). Discard all parts and hardware (Figure 3; Figure 4).

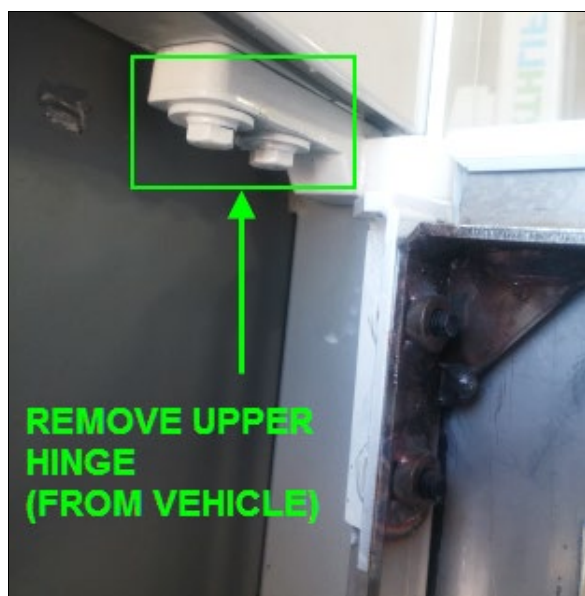

FIGURE 3: UPPER HINGE REMOVAL VEHICLE SIDE



FIGURE 4 UPPER HINGE REMOVAL DOOR SIDE

4. Install the new upper hinge (parts **280504**, **280549** & **280610** in kit Figure 5) making sure that:

- New M6 bolts and washers (**5000310** & **5001833**) are used at the upper (vehicle structure) mounting points (Figure 5).
- New M6 bolts (**502622** & **5001833**) are used at the door mounting points (Figure 5).
- A new plastic bushing **284607** is installed at the pivot point (Figure 6).

- The door is fully supported by the *lower hinge* and not slightly lifted-up by the lift table so there is no gap between parts at the lower pivot point (Figure 7).
- There is no gap between the upper and lower part at the pivot point of the upper hinge (Figure 8).
- The four M6 bolts are torqued to **68 lb-in** (apply blue Loctite 242 or equivalent medium strength thread locker on all fastener threads (Figure 9).

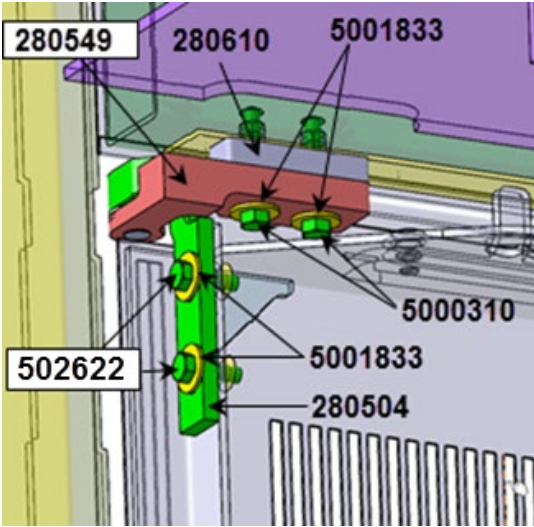

FIGURE 5: NEW UPPER HINGE

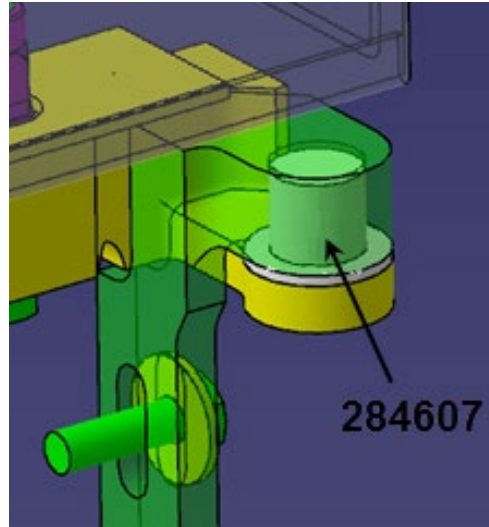

FIGURE 6: BUSHING



FIGURE 7: LOWER HINGE SUPPORT

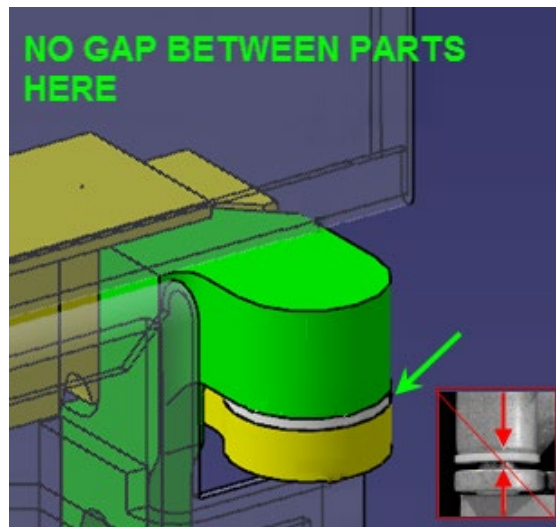

FIGURE 8: NO GAP – UPPER HINGE

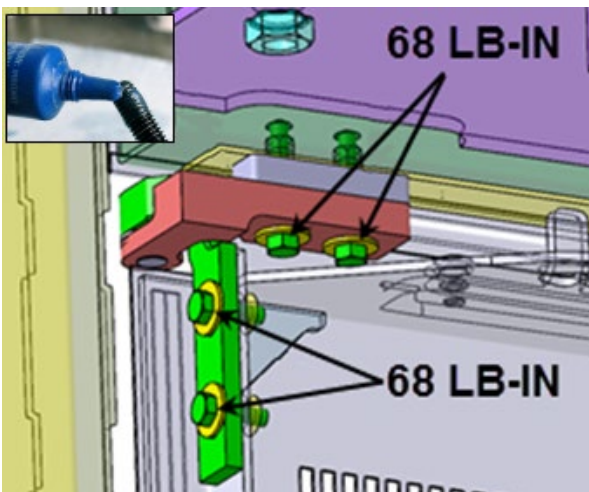

FIGURE 9: TIGHTENING TORQUE- UPPER HINGE ; APPLY THREAD LOCKER

## B. ROLLER SUPPORT ADDITION ON COMPRESSOR DOOR



### Install catch PIN



P/N	Desc.	Qty
280567	Catch Pin retainer	1
280599	Shim spacer	2
5001912	Screw cap M8-1.25x30	2
5001868	Washer Belleville	2
5001063	Rivet nut M8-1.25	2

### Install Roller



P/N	Desc.	Qty
280589	Roller	1
5001461	Screw FL Ph M8-1.25x40	1
5001983	Nut NYRT M8-1.25 SS	1

## C. COMPRESSOR DOOR LOWER HINGE REPLACEMENT

1. Support door by the lower edge.
2. Unscrew, remove & discard the *vehicle structure part* of the condenser door lower hinge (3X M6 bolts Figure 10)

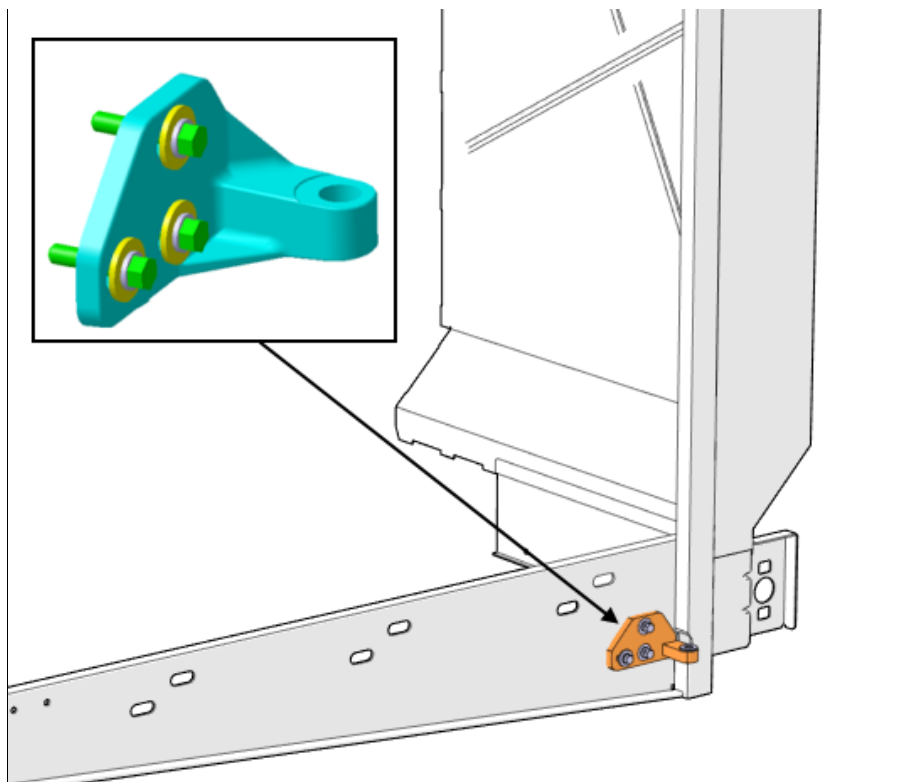

FIGURE 10: HINGE PART TO BE REMOVED (COMPRESSOR DOOR)

3. Remove the two rivnuts (two vertical holes) by drilling them using a 3/8in drill bit (Figure 11).

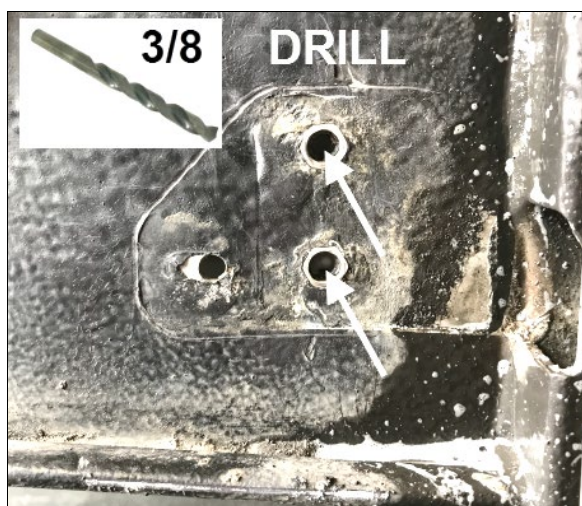

FIGURE 11: LOWER HINGE RIVNUTS

4. Loosen the battery tray to allow the installation of the reinforcing plate.
  - Support the battery tray using a hydraulic bottle jack or other suitable equipment (Figure 12).



FIGURE 12: SUPPORTED BATTERY TRAY

- Loosen the three front bolts (Figure 13)

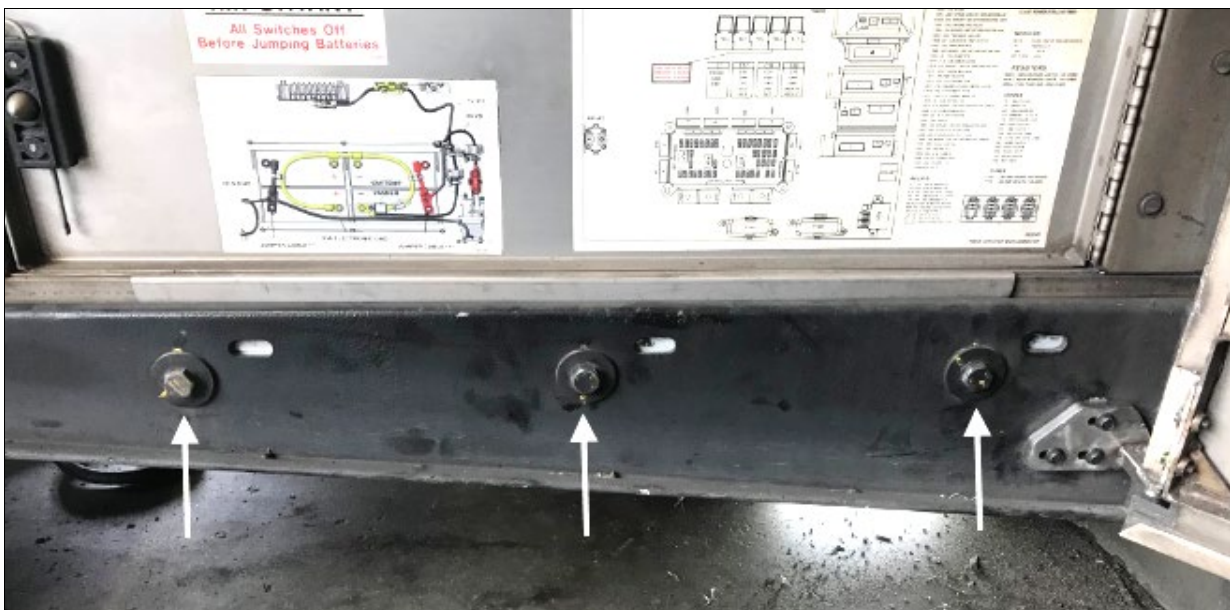

FIGURE 13: FRONT BATTERY TRAY BOLTS

- Loosen the three bolts underneath the battery tray (Figure 14).



FIGURE 14: BATTERY TRAY BOLT (3X UNDERSIDE)

5. Move the battery tray back approximately 1/4in (7mm) to make room for the reinforcing plate and shims.
6. Position the **7770484** reinforcing plate so it covers all 3 hinge holes at the back of the structure (slide the top right corner between the frame and the battery tray (Figure 15).

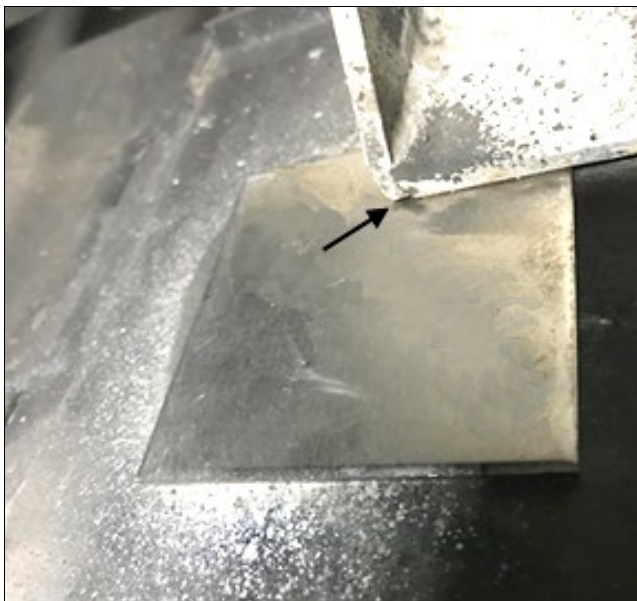

FIGURE 15: 7770484 PLATE POSITIONNED OVER HOLES

8. Mark the center of the lower M6 bolt on the plate using a sharpie (Figure 16).



FIGURE 16 : MARKING THE PLATE WITH A SHARPIE PEN

9. Remove the plate and drill the marked position using a 1/4in drill bit.
10. Reposition the drilled plate on the vehicle and secure with one of the supplied bolt/nut (**5001815**, **502854**) (Figure 17).

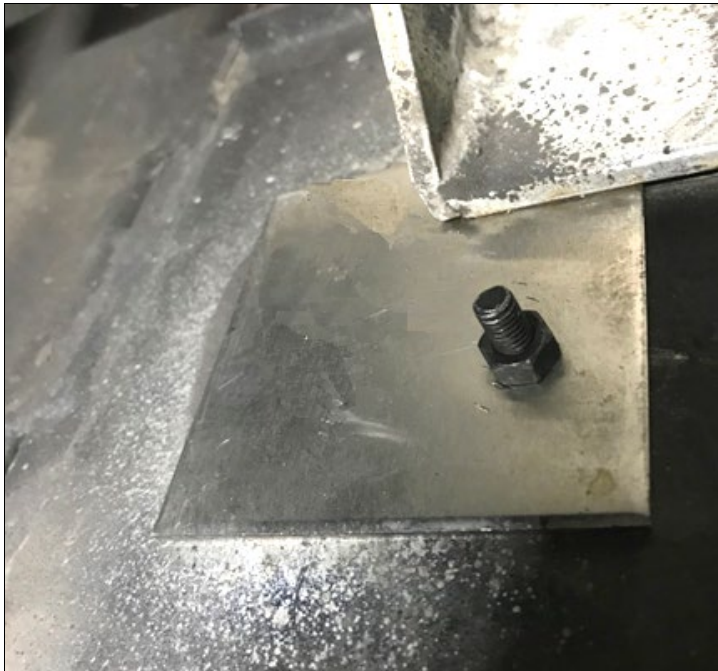

FIGURE 17 7770484 PLATE POSITIONNED FOR DRILLING

11. Drill the two remaining holes using a 1/4in drill bit.

12. Install the new stainless steel lower hinge **2810294** making sure that:

- Mounting surfaces are cleaned from old undercoating using emery cloth or sandpaper (expose primed frame surfaces – not bare metal).
- New plastic bushing **284607** and washer **502723** are installed at the pivot point (Figure 18).
- Door is fully supported by the *top hinge*, not the lift table (no gap at the top pivot point) (Figure 19).
- New M6 bolts, nuts, locks & washers (**5001815, 502854, 502570 & 430406**) are used to secure the lower hinge at the vehicle structure point (Figure 20).
- The stainless reinforcing plate (**7770484**) is installed at the backside of the frame (plate must be installed between the frame and the battery tray floor (Figure 22).
- Door is adjusted properly. There should be an even (parallel) gap of at least 0.080" (2mm) at the top of the door and a 0.177" +/- 0.060" (4.5 +/-1.5 mm) gap between the door and the vehicle rear fender (see step 17 below for final adjustment details).
- All bolts are torqued to **84 lb-in** (apply blue Loctite 243 or equivalent medium strength thread locker on all fastener threads & apply a stripe of tamper proof indicator paint (torque seal) to the bolt heads (Figure 21).

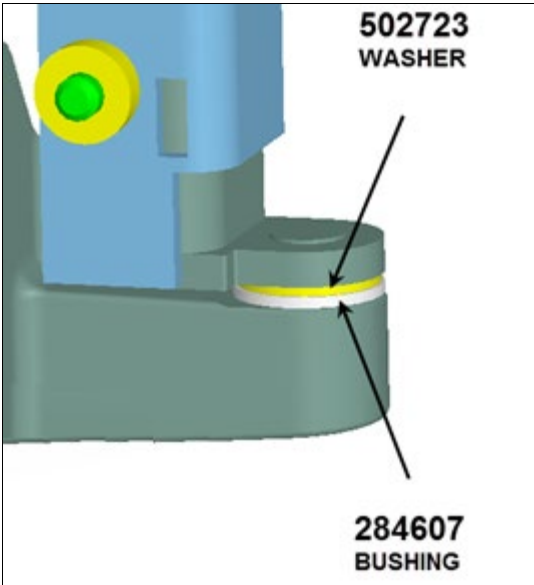

FIGURE 18: WASHER & BUSHING POSITION

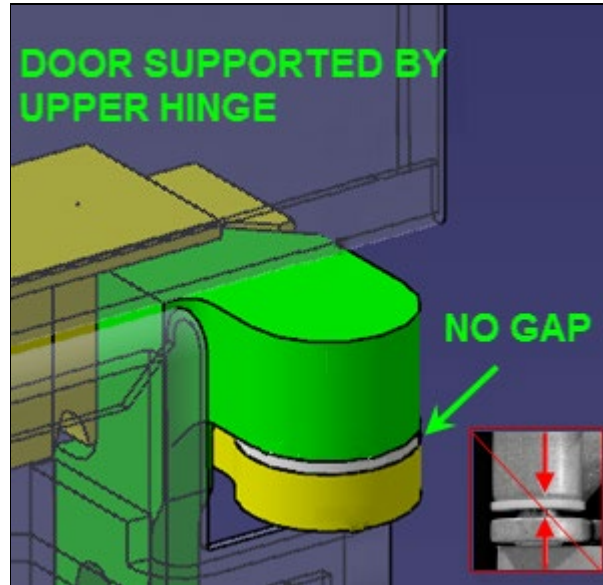

FIGURE 19: UPPER SUPPORT- NO GAP ALLOWED

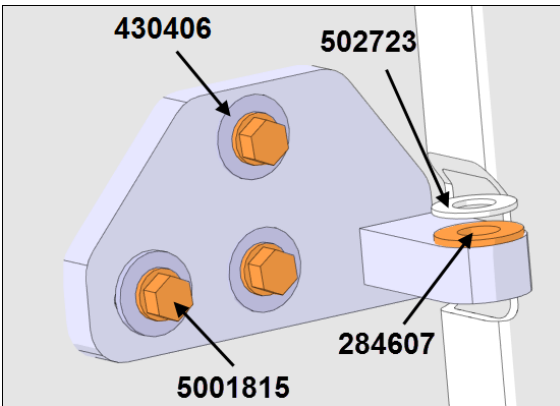

FIGURE 20: LOWER HINGE COMPONENTS

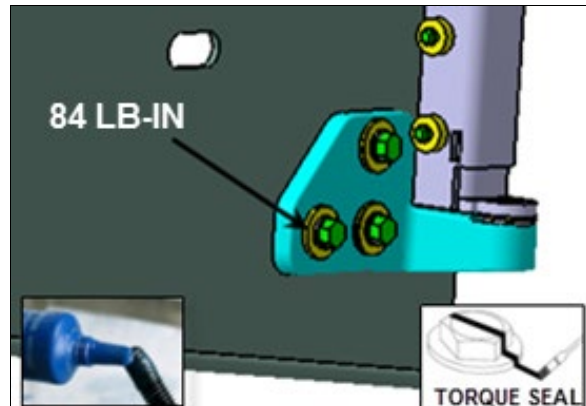

FIGURE 21: TIGHTENING TORQUE



FIGURE 22: REINFORCEMENT PLATE INSTALLED

13. Remove the battery tray bolt one by one to apply blue Loctite 243 or equivalent medium strength thread locker to the threads (do all 6 bolts).
14. Tighten the screw halfway.
15. Insert a **030082** shim between the tray and the frame at all bolt location and tighten the bolts (Figure 23 & Figure 24).



FIGURE 23: SHIM LOCATION

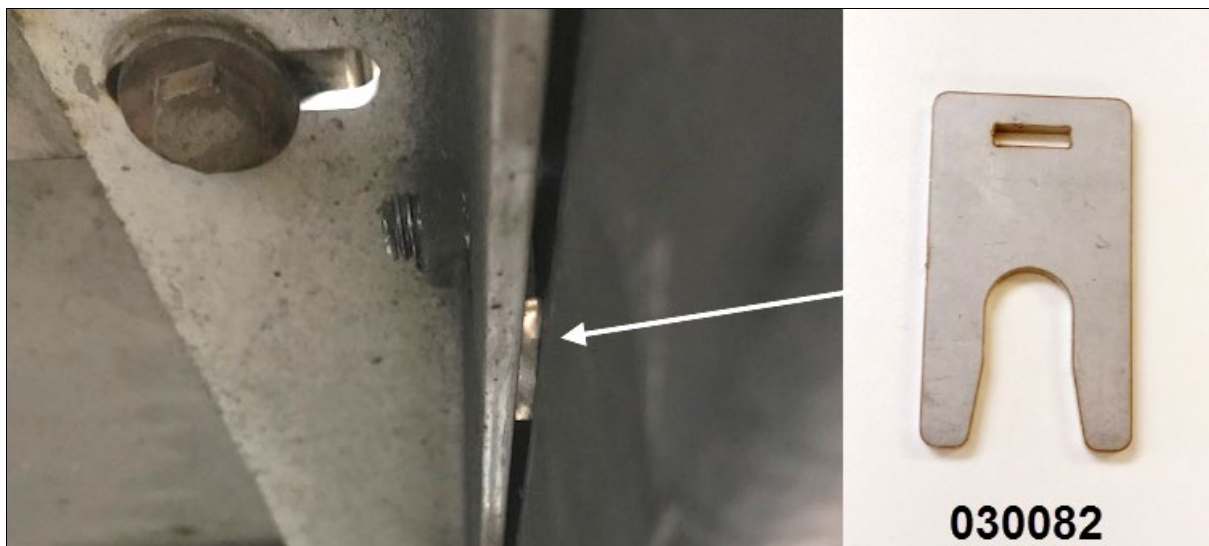

FIGURE 24 INSTALLED 030082 SHIM

16. **Re-Torque the 6 bolts to 47 lb-ft** & apply a stripe of tamper proof indicator paint (torque seal) to the bolt heads.
17. Remove door support installed at step 2 and open and close the door several times to make sure it is working properly, check door top and side adjustments. There should be an even (parallel) gap of at least 0.080" (2mm) at the top of the door and a 0.177" +/- 0.060" (4.5 +/-1.5 mm) gap between the door and the vehicle rear fender (Figure 25).



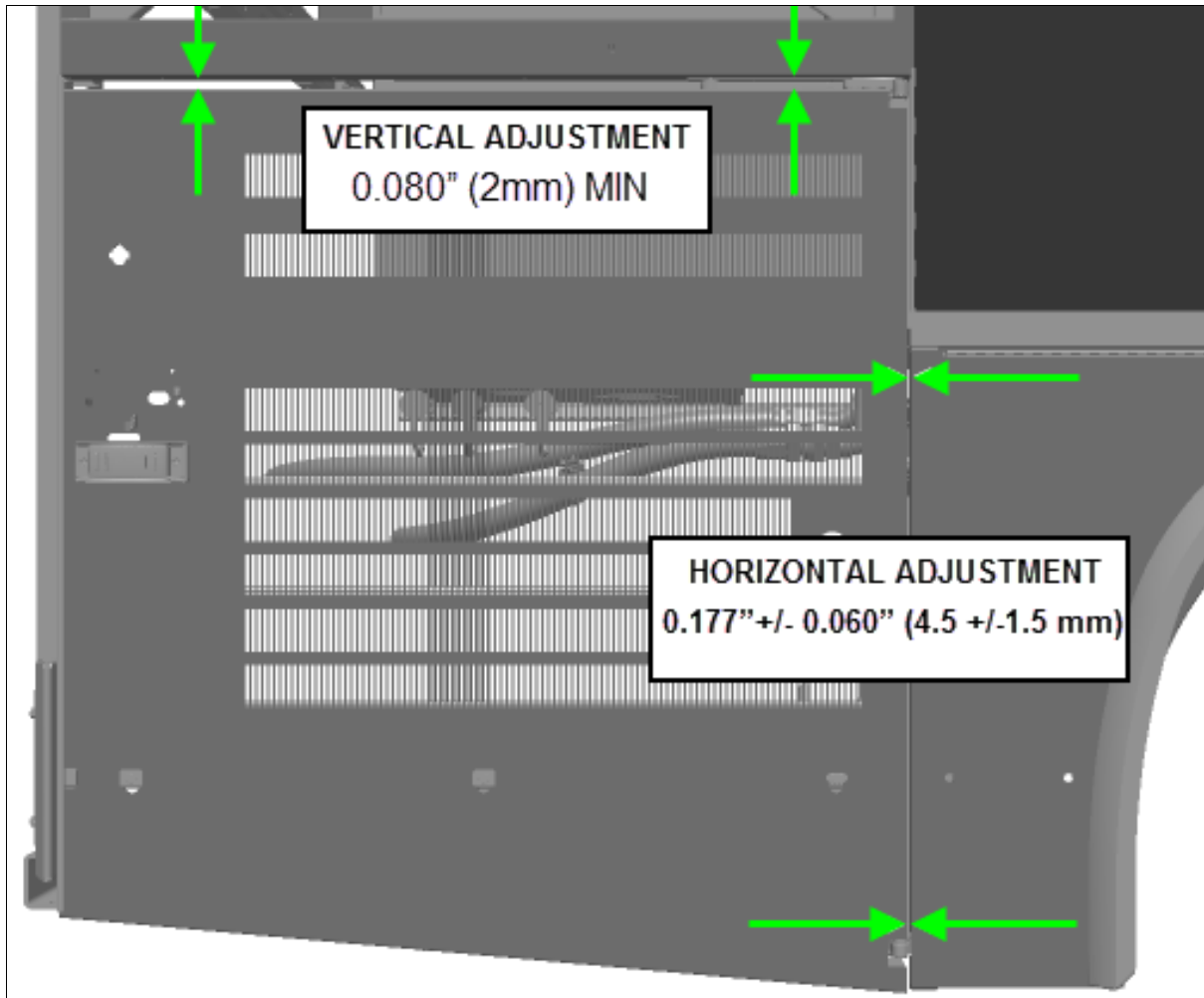

FIGURE 25: COMPRESSOR DOOR HORIZONTAL & VERTICAL GAPS

**NOTE**

*If gap is out of spec the compressor door may be adjusted for proper fit by untightening hinge bolts:*

- *Loosen the bolts holding the hinges to the vehicle structure to shift the door horizontally LEFT or RIGHT.*
- *Loosen the bolts holding the hinges to the door frame to shift the door vertically UP or DOWN.*
- *If upper hinges must be readjusted, re-torque the upper fasteners to **68lb-in***

18. Make sure that there is a stripe of tamper proof indicator paint (torque seal) on all hinges bolt heads.

## D. CONDENSER RELOCATION OVERVIEW

- The old road side condenser coil is removed and discarded.
- Hose from filter dryer to front evaporator pipe is discarded.
- Hoses to and from old condenser are discarded.
- Hose from compressor to service valve is discarded.
- Keep the filter dryer, associated piping and accessories.
- Keep wiring, remove cable ties. Relocate.
- Keep the service valve and associated piping.
- Compressor location remains the same.

See image below for a representation of the final arrangement.

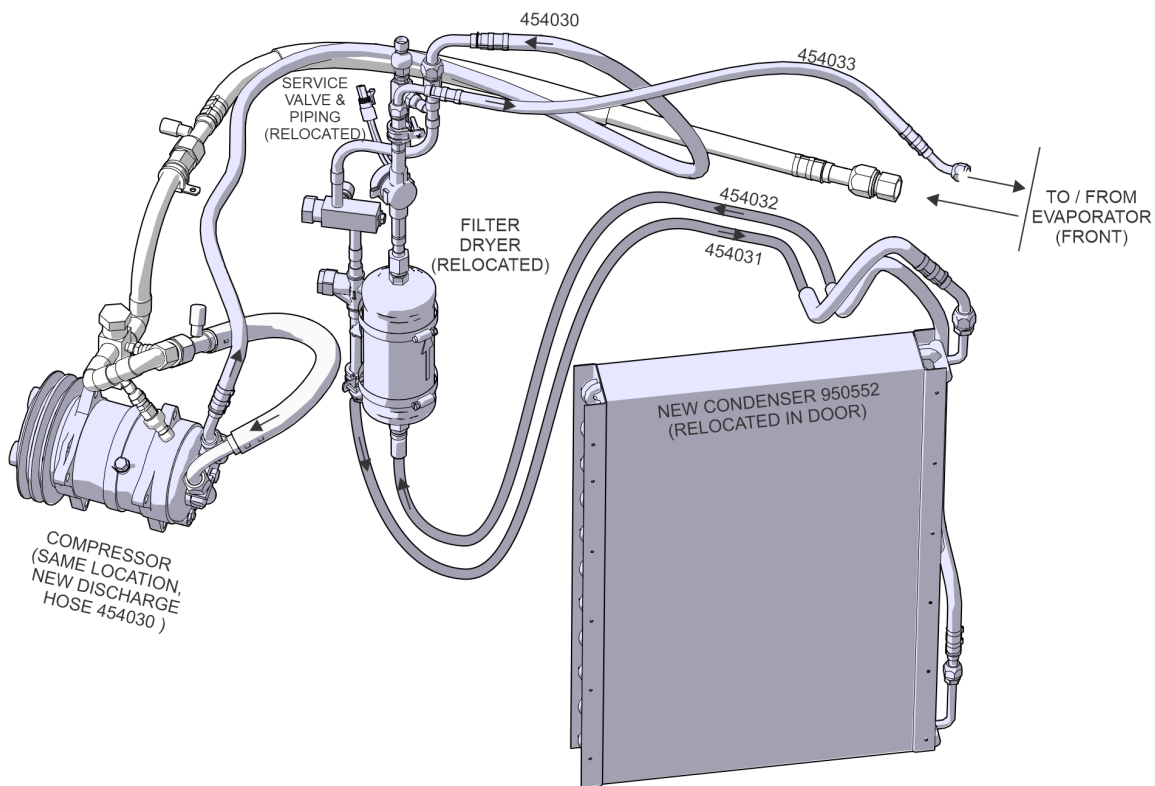
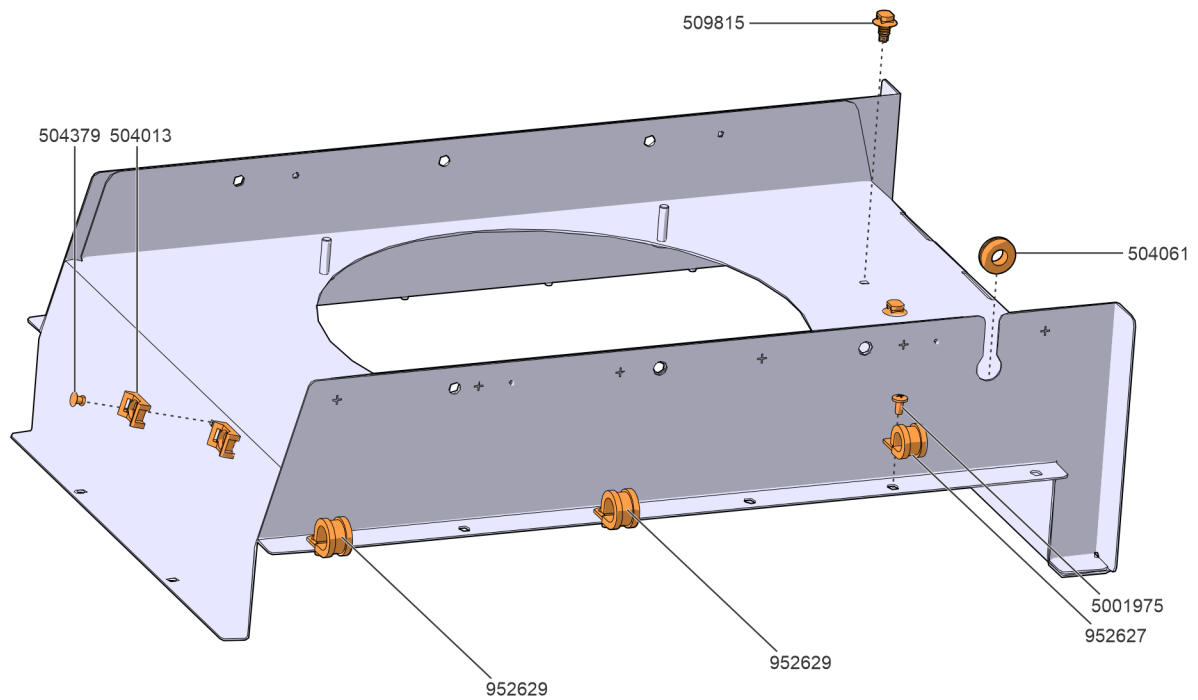

FIGURE 26: OVERVIEW FROM F-5740 SHOWN

## E. CONDENSER RELOCATION AND PREPARATION

19. Reclaim all refrigerant from system. Proceed with best practices.
20. On 454037 shroud assembly, install cable and hose management accessories shown on Figure 27

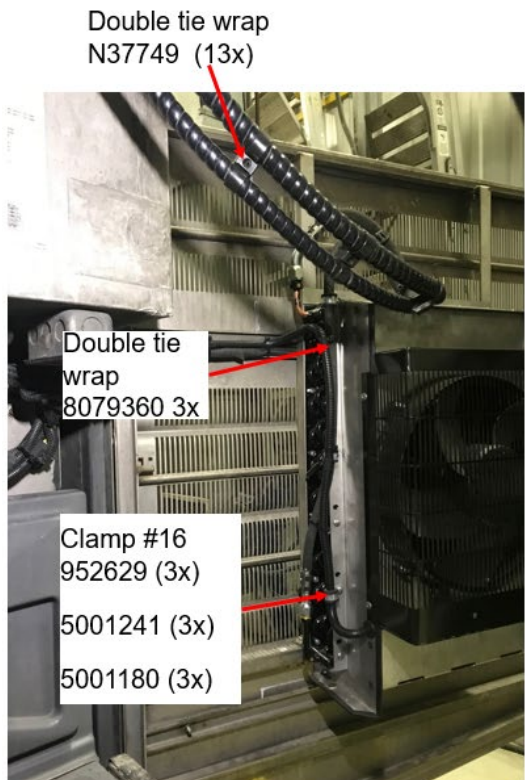

**FIGURE 27: 454037 PRE-ASSEMBLY**

## F. CONDENSER INSTALLATION

21. Install new condenser, electric fan and accessories inside compressor door.

### Condenser installation



Part Number	Description	Quantity
5001983	NUT HEX NYRT SS NSS,M8X1.25	2
5001448	WSH FL SS .343X.875X.040 (M8,5/16)	2
502780	SCR CAP HEX SS NSS M8X25	2

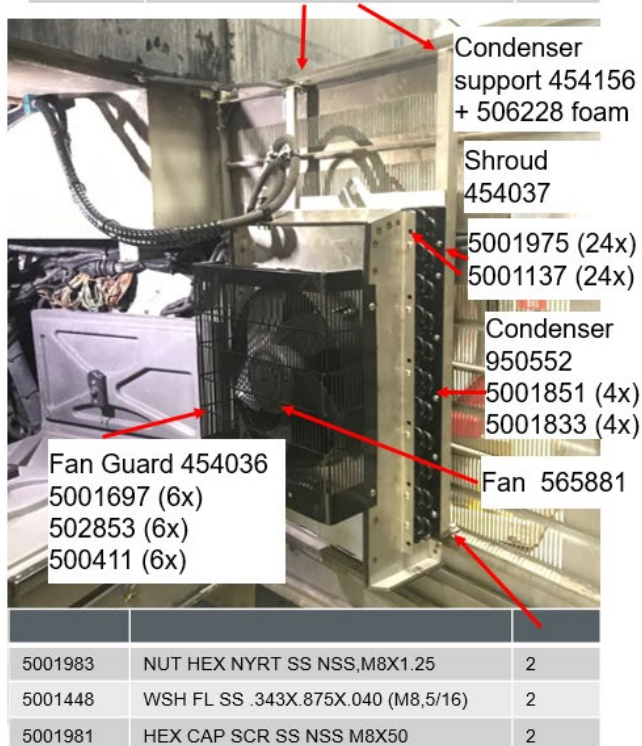

Part Number	Description	Quantity
5001983	NUT HEX NYRT SS NSS,M8X1.25	2
5001448	WSH FL SS .343X.875X.040 (M8,5/16)	2
5001981	HEX CAP SCR SS NSS M8X50	2

**FIGURE 28: NEW CONDENSER, FAN AND ACCESSORIES**

## G. A/C HOSE INSTALLATION

22. Route hoses as shown using hardware below. Use 504751 dual saddle swivel type cable tie mount as required to prevent rubbing.

504727	Clamp double hose 3/8"	2
504728	Plate retainer	2
500107	SCR TC CAP HEX 1/4 -20 x 2"	2

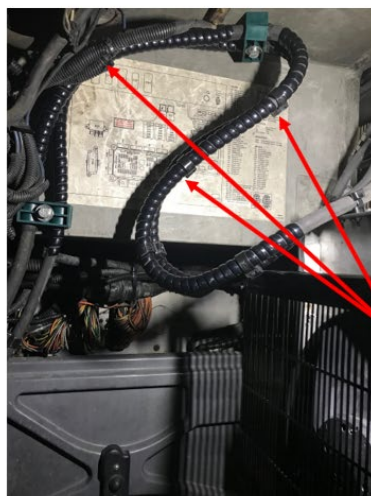

Hose #8  
Service  
valve to  
condenser  
inlet  
#454031

N37749



Hose #6  
Condenser  
outlet to dryer  
#454032

Clamp #24  
952634 (2x)



500607 (2x)  
5001180 (2x)  
504357 (2x)

Clamp #16  
952629 (2x)



**FIGURE 29: A/C HOSE ROUTING**

## H. FILTER DRYER INSTALLATION

23. Remove filter dryer from original location on vehicle. Disconnect hoses.
24. Keep the complete arrangement: filter dryer and associated piping, service valve piping and pressure switch, including the assembly's mounting bracket and mounting hardware.



FIGURE 30

25. Mount the new filter dryer post 454035 to battery box frame using M10 x 25 screw 502655 5001758 M10 Stover nut and existing hardware on battery box frame



FIGURE 31: INSTALL FILTER DRYER POST

27. Mount reserved filter dryer bracket to new post with reserved M8 hardware. Two types of bracket are present depending on VIN.
28. From E-5459 to E-5739 adjust position to fit and drill 8mm (5/16") holes.
29. From F-5740, use existing holes.

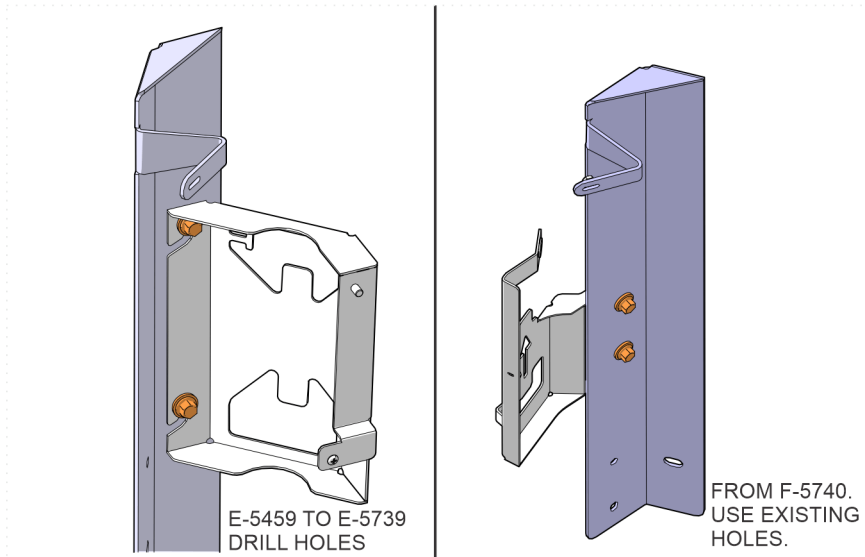
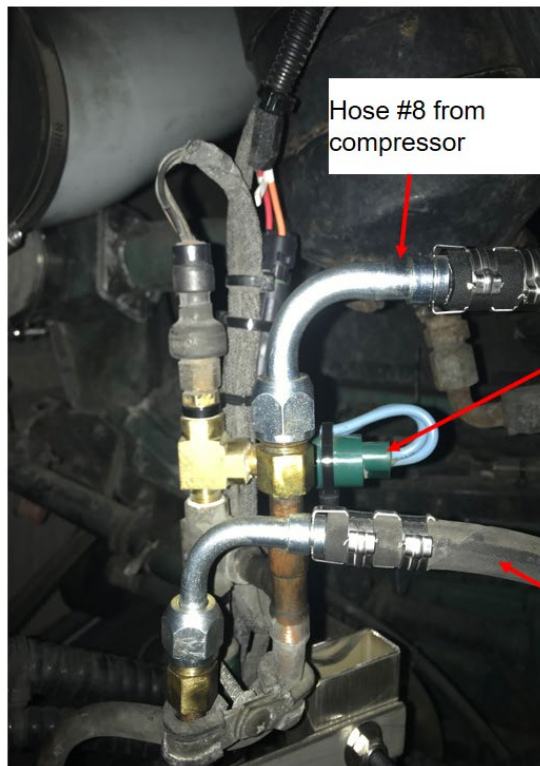

FIGURE 32: FILTER DRYER BRACKET ON POST

## I. PRESSURE SWITCH INSTALLATION

30. Add a pressure switch 950270, Tee fitting, Schrader valve and connector sharing the same pressure measuring point as the existing pressure transducer.



Part Number	Description	Qty
950270	NO PS 170-130 PSI	1
950249	Schrader valve ¼ NPT	1
501338	T fitting ¼ NPT	1
561566	Connector Pin Housing	1
561567	Terminal	2
561565	seals	2



# J. WIRING HARNESS INSTALLATION

Wiring Harness #0610379  
Tie wrap 504637 (30x)



Relay  
563332 (2x)

Fan condenser plug Mo7

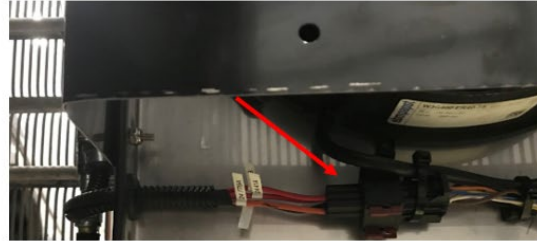

Splice wire 77BA with wire at A52 J1:20



Ground  
wire  
OCD1

Connect wire 41 at VECR2:E

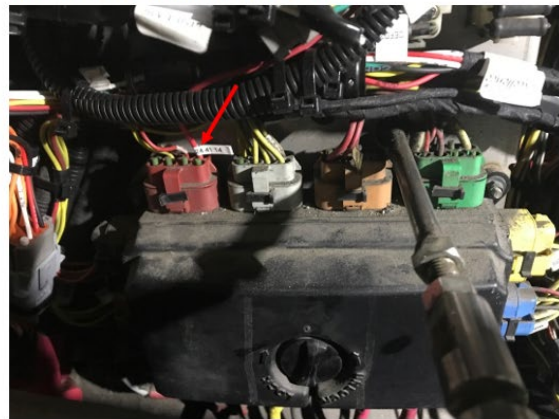

## K. VPG: PARAMETER SETTING

Vehicle ID#:   Messages: \*\*\* Other version of programs available \*\*\*  
RECOMMENDATION: Generate and Transfer the Multiplex program!  
Vehicle generic program has changed since last generation!

General | Vehicle Parameters | Program Generation | Transfer to the Vehicle | Vehicle History

**Vehicle Info**

VIN #: 2PCC33494FC735807	Vehicle Type: MTH XL2 45E	Software ID as shown in the Vehicle MCD
Sales Order: 0004046183 000010	Status: In Service	MID 188 SW ID
Production Order: 000007017979	Production Date: 2014/10/24	70403450P02*06100061
		P43*00155807A14*

**Vehicle Events Data**

Current Data	Last Generation	Last Transfer
User name: Jean Ruel (Service Rep.)	MLO Service (Garage Miraloma)	MLO Service (Garage Miraloma)
Date/hour: 2020/01/17 15:49:44	2019/10/14 11:17:55	2019/10/14 08:38:55
Parameters: 00155807 Rev:A15	00155807 Rev:A15	00155807 Rev:A14
Program/Date: 06100061 Rev:P44 2020-01-16	06100061 Rev:P43 2017-10-03	06100061 Rev:P43 2017-10-03

Description: Added parameter (EFDSAC) for aftermarket EFD option on Small A/C equipped vehicles. Parameter disables cooling request from A/C system to radiator fans.  
Function 06200295 updated to P07  
Function 06200367 updated to P12

Vehicle ID#:   Messages: \*\*\* Other version of programs available \*\*\*  
RECOMMENDATION: Generate and Transfer the Multiplex program!  
Vehicle generic program has changed since last generation!

General | Vehicle Parameters | Program Generation | Transfer to the Vehicle | Vehicle History

Compare parameter values between  and

Para	Description	S	Default Value	Previous Value	Current Value	New Value
EFDSAC	Aftermarket EFD Kit on Small AC eq	N	Without			With

### PARTS / WASTE DISPOSAL

Discard waste according to applicable environmental regulations (Municipal/State[Prov.]/ Federal)