P R E V O S T

Instructions Sheet

IS-94088

CONVERTING A/C SYSTEM FROM R12 TO R134a REFRIGERANT

DESCRIPTION

Vehicles with R12 refrigerant-charged air conditioning systems can be converted to systems charged with R134a refrigerant using the parts and procedure supplied with this instruction sheet.

MATERIAL

The 3 following kits are required to retrofit "XL" vehicles (F-828 up to H-277 inclusively) equipped with driver's and central HVAC units.

FIRST KIT: #45-2621

Description of Kit #45-2621

Part no	Description	Qty
45-2540	Expansion Valve (Central system)	1
95-0221	Expansion Valve (Driver's system)	1
87-0890	Pressure Relief Valve (450 psi)	1
45-2524	Filter Dryer Assembly	1
45-2547	Filter Dryer Support	1
50-4025	Hose Clamp	2
95-0234	Cap (red) with gauge adapter fitting	2
37-3306	Label - R134a	2

SECOND KIT:

As per customer's choice, the second kit may consist in either, a modification to the existing compressor (kit #45-2620) or in the installation of a new compressor assembly (compressor assembly #95-0243 for vehicles powered with a series 92 engine and #95-0238 for those with a series 60 engine).

Note: When installing a new compressor assembly (#95-0243 or #95-0238), pressure switches #45-2405 and #45-2406 are also required.

Description of Kit #45-2620

Part no	Description	Qty
45-2405	Switch Assy (20PS001MB320K) - High Pressure (320-245 psi)	1
45-2406	Switch Assy (20PS001MA030C) - Low Pressure (30 - 15 psi)	1
95-0244	Switch Assy (12-00299-09) - High Unload	1
95-0245	Switch Assy (12-00334-02) - Low Unload	1
95-0246	Switch Assy (12-00334-03) - Low Unload	1
95-0030	Schrader Valve	5
95-0234	Cap (Red) with gauge adapter fitting	1
95-0235	Cap (Blue) with gauge adapter fitting	1
95-0095	Electric Unloader Valve	2
06-3969	Unloader Coil Assy 24V dc	2
50-1653	Street Tee (1/8")	2
50-1894	Tee (1/4")	1
50-1312	Bushing 1/4" x 1/8"	3
87-0754	Suction Service Valve Gasket	1
95-0250	Wiring Harness	1

THIRD KIT:

Kit #45-2660 with the following additional hoses depending on vehicle identification number.

Part no	Description	V.I.N	
		F-828 to F-869	F-870 to H-277
45-2535	Hose 86" - Driver's Evaporator Outlet	1	1
45-2536	Hose 54" - Filter Outlet (towards Driver's Unit)	0	1
45-2538	Hose 14" - Driver's Liquid Inlet	1	1
45-2539	Hose 65" - Driver's Evaporator Inlet	1	1
45-2653	Hose 13" - Filter Outlet (towards Driver's Unit)	1	0

Description of kit #45-2660

Part no	Description	Qty
45-2658	Hose (33" lg) - Compressor Discharge	1
45-2555	Hose (41" lg) - Compressor Suction	1
45-2530	Hose (62" lg) - Condenser Inlet	1
45-2533	Hose (71" lg) - Condenser Outlet	1
45-2643	Hose (31" lg) - Receiver Tank Outlet	1
45-2534	Hose (50" lg) - Filter Outlet (Filter to Expansion Valve)	1
45-2532	Hose (4" lg) - Evaporator Inlet	1
45-2526	Hose (56" lg) - Suction	1
45-2527	Hose (10" lg) - Evaporator Outlet	1
45-2654	Hose (17" lg) - Suction	1
50-7169	O-ring - Filter Drier Outlet to copper pipe (1)	1
50-7209	O-ring - Condenser Outlet (2) & Evaporator Inlet (1)	3
50-1802	O-ring - Compressor Discharge (2) & Condenser Inlet (2)	4
50-1803	O-ring - Compressor Suction (2) & Suction Hose (2) & Evaporator Outlet (2)	6
50-7279	O-ring - Expansion valve (driver's unit)	2
IS-94088	Instruction sheet	1
IS-94089	Instruction sheet	1
FI-94088	Feuille d'instructions	1
FI-94089	Feuille d'instructions	1

EQUIPMENT AND MATERIALS REQUIRED:

1. A recovery or reclaim system designed and approved for use with the refrigerant being removed; e.g. an R12 machine for R12 refrigerant.
2. Containers for the refrigerant being removed.
3. A vacuum pump capable of 500 microns (0.04 psi or 0,28 kPa).
4. A micron gauge in good operating condition.
5. Containers to handle the contaminated oil generated by the cleaning process (about 11 liters total).
6. A basic set of refrigeration servicing equipment and hand tools.
7. A small flashlight to check compressor oil and charge levels.
8. Loctite Threadlocker #271.
9. Service manifold gauge set and proper evacuation hoses.
10. A leak detector designed to detect the presence of R134a refrigerant.

-
11. Rubber gloves and eye protection.
 12. Hand rags and other shop supplies.
 13. R134a refrigerant (24 lbs).
 14. New "Ester-based" oil*. Approximately 11 liters are required. About 7 liters will be used for cleanup, the remainder for the final fill. Only 7 liters are required when installing a new compressor since the sump of the latter is already filled with "Ester-based" oil.
 15. The appropriate R134a refrigerant conversion kits for the vehicle being converted.

* Prevost recommends Castrol Icematic SW68 Ester-based oil. Call Castrol Inc. to determine the authorized distributor nearest you.

Castrol Canada Inc.
Tel: (416) 252-5511
Fax: (416) 252 1774

U.S.A. Castrol Inc.
Tel: (714) 660-9414
Fax: (714) 660-9374

PROCEDURE

Warning: Use safe shop practices at all times. Only properly trained and certified shop technicians should conduct this work.

Read the entire procedure before beginning work.

A/C COMPRESSOR OIL REPLACEMENT

Note: The following steps apply even if a new A/C Compressor will be installed.

1. With system running, close off the compressor suction service valve, pumping the compressor down. Refer to "Pumping down procedure" in the Maintenance Manual. Stop the vehicle engine, unplug the compressor clutch (to ensure that no one can run the system) and close off the compressor discharge service valve to isolate the compressor from the system.

2. Install a reclaimer or recovery machine.

Warning: Equalize compressor internal pressure **before** removing the oil drain plug. Failure to do this may result in personal injury. Low side pressure must be 0.0 psi.

3. Lower A/C compressor oil level until oil is level with sight glass lower rim.

Warning: Personal protection such as rubber gloves and safety glasses should be worn.

4. Open all valves, connect compressor clutch then run the system with maximum load to keep the flow of refrigerant through the system as high as possible and allow in this way maximum oil to return to the compressor sump. Run the system at high idle (1000 rpm) for 1 1/2 to 2 hours.

Caution: The ambient temperature around the vehicle and at the interior (passenger area) must be kept above 70°F. The interior temperature can be elevated by opening the vehicle entrance door and windows or by forcing the unit into full heat while the air conditioning switch is "ON". Failure to do this will slow down the flow of oil through the system and result in a higher percentage of the existing oil left in the system. This could be detrimental to the performance of the system and may result in costly damage.

5. If the oil level raises higher than the middle of compressor sight glass, repeat steps 2 to 4.

6. Drain the A/C compressor sump from all mineral-based oil. This is contaminated oil and must be handle accordingly. Do not reuse this oil.

7. Refill the A/C compressor sump with new "Ester-based" oil until level with sight glass lower rim (approximately 3.5 liters).

8. Run the system for a second time repeating previous step 4.

9. Drain and refill A/C compressor sump repeating previous steps, then run the system (for the last time) repeating step 4 above.

REFRIGERANT R12 RECOVERING

Remove the existing refrigerant from the system using proper reclaimer or recovery machine. **DO NOT** vent to the atmosphere.

A/C COMPRESSOR RETROFITTING

Note: The following steps don't apply when installing a new compressor assembly. In a such case, refer to heading "Installing a new compressor" later in this publication.

1. Replace both mechanical unloaders with new electric unloaders (95-0095 + 06-3969) following these steps:

- a. Remove the three socket head capscrews mounting the mechanical unloader to the cylinder head (the unloader power head can be removed to ease capscrews removal).
- b. Scrape all gasket material from the cylinder head and flange cover.
- c. Assemble electric unloader as illustrated in figure 1.

- d. Install the new electric unloader using the new gasket supplied with it. When installing the gasket, align the small crescent-shaped cutouts in the gasket with the gas port (figure 1).
- e. Mount the assembled unloader to the cylinder head using the three new socket head capscrews and washers supplied with the new unloader. Torque capscrews to 12-16 lbf-ft (16-22 N•m).

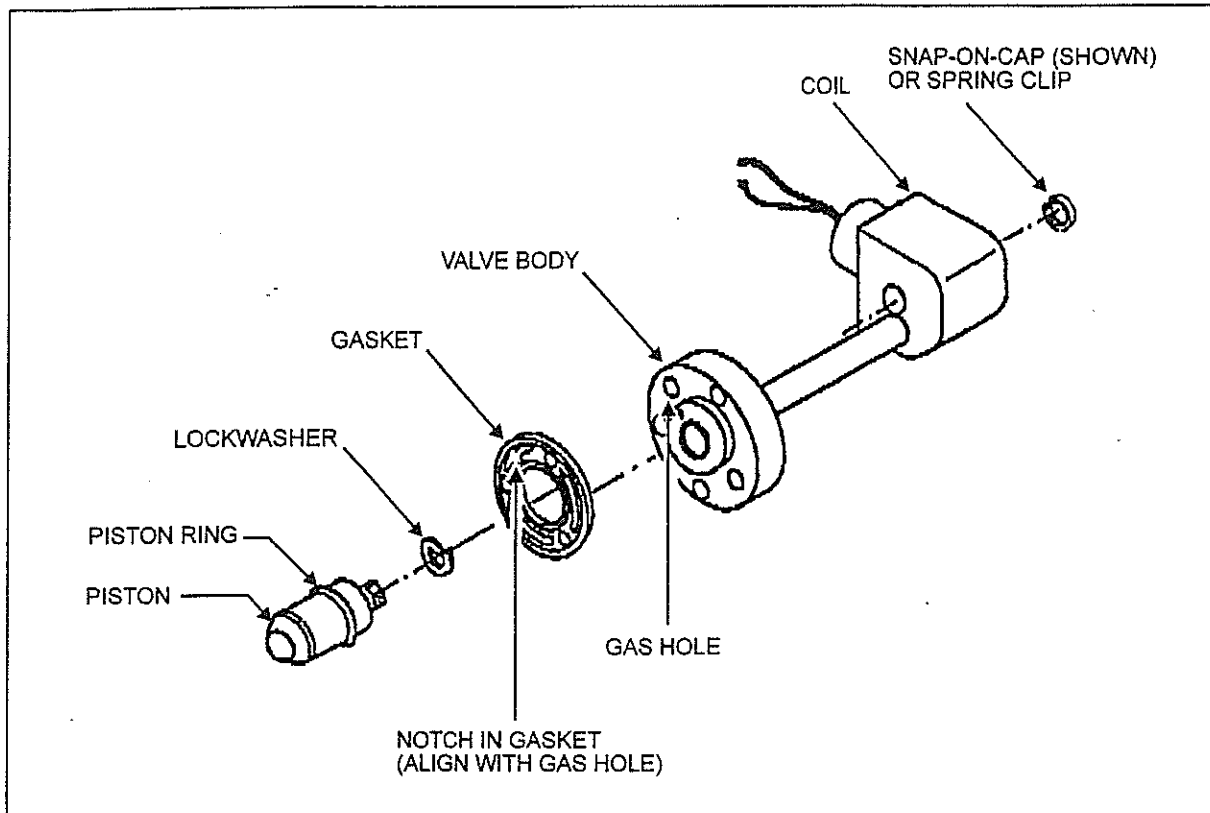

Fig. 1 - Electric Unloader Assembly

22005

2. Remove and discard the low pressure switch (and bushing or elbow if applicable) from compressor body, install a Tee (#50-1894) at an angle pointing to right rear corner of vehicle, two bushings (#50-1312), a street Tee (#50-1653) then three "Schrader" valves (#95-0030) as illustrated in figure 2.

Note: Prevost recommends applying "Loctite" threadlocker #271 on threads of all fittings provided with a "pipe thread".

3. Install both low pressure unload switches (#95-0245 & #95-0246) and low pressure switch (#45-2406) on "Schrader" valves as illustrated in figure 2.

Note: Do not apply "Loctite" on "Schrader" valves' countersunk edge nor to pressure switches' inner countersunk edge.

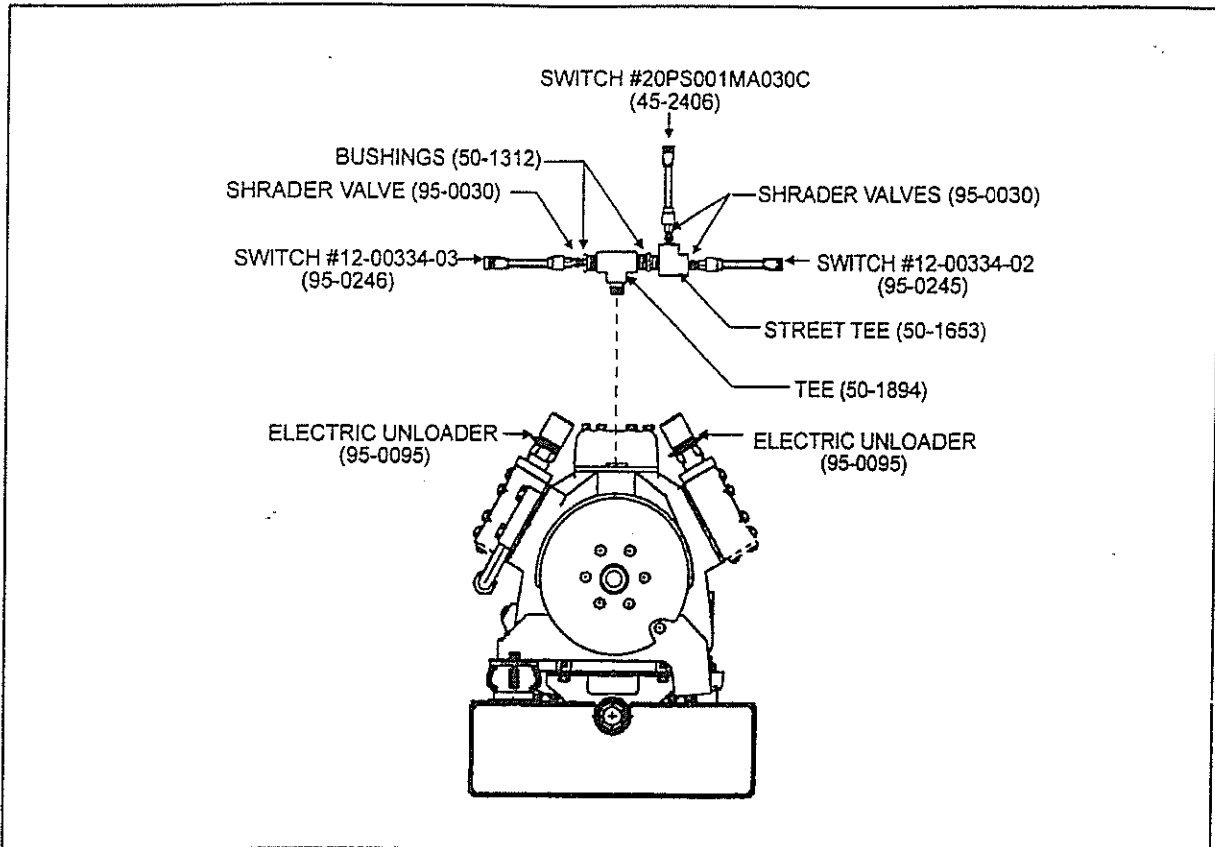

Fig. 2 - Pressure Switch Installation (Suction side)

22007

4. Remove and discard the high pressure switch (and bushing or elbow if applicable) from compressor head. Install a bushing (#50-1312), a street tee (#50-1653), then two "Schrader" valves (#95-0030) as illustrated in figure 3.

5. Install the high pressure switch (#45-2405) and the high pressure unload switch (#95-0244) on "Schrader" valves as illustrated in figure 3.

6. Remove the sealing cap from the gauge connection on the suction service valve, discard, then install gauge adapter with sealing cap (blue) #95-0235.

7. Remove the sealing cap from the gauge connection on the discharge service valve, discard, then install gauge adapter with sealing cap (red) #95-0234.

8. Replace the existing compressor suction and discharge hoses with new hoses from the kit. Replace the O-rings at the hose connections with the new O-rings from the kit. Refer to figure 7 for hose and O-ring identification and location.

Note: Lubricate the "O-rings" with white grease before installing.

Note: If suction hose cannot be removed for lack of space, remove suction service valve from compressor and separate hose from valve in shop vice. Assemble new hose to valve, replace gasket then reinstall on compressor. Torque suction service valve bolts to 55 - 80 lbf•ft (75 - 108 N•m).

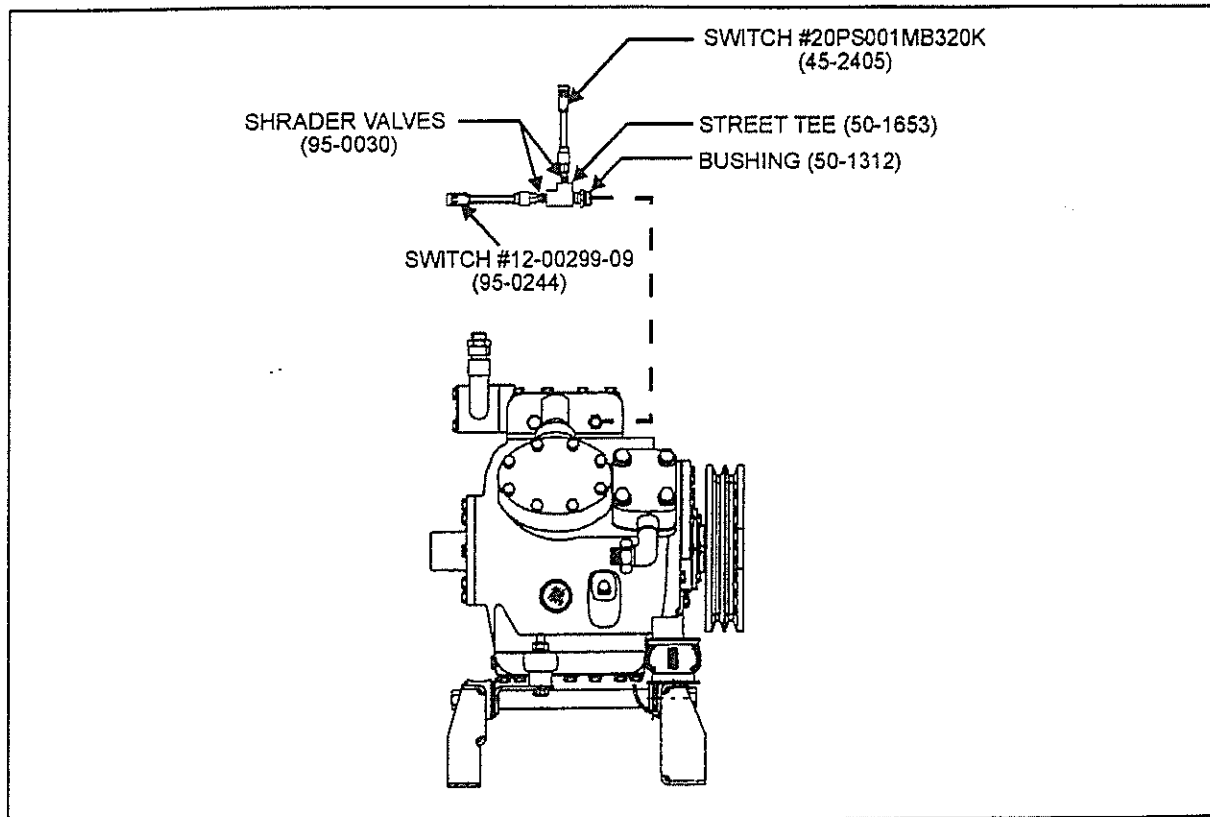

Fig. 3 - Pressure Switch Installation (Pressure side)

22008

9. Connect the existing female connector (C-52) to the High Pressure Switch #20PS001MB320K (Prevost #45-2405) illustrated in figure 3.

Note: The existing connector (C-52) may not fit with the connector of new High Pressure Switch, in such a case, remove connectors and solder wires together. Insulate the junctions using shrinkable tubings (not included).

10. Connect the existing male connector (C-53) to the Low Pressure Switch #20PS001MA030C (Prevost #45-2406) illustrated in figure 2.

Note: The existing connector (C-53) may not fit with the connector of new Low Pressure Switch, in such a case, remove connectors and solder wires together. Insulate the junctions using shrinkable tubings (not included).

11. Trace hot wire of A/C compressor clutch up to connector C-54, disconnect, then connect at this place the male connector of new wiring harness #95-0250.

12. Remove male contact pin from the end of A/C compressor clutch hot wire (disconnected at previous step), strip extremity then solder to the loose wire coming from the same splice as wire connected at the previous step (see fig. 4).
13. Connect ring terminal of new wiring harness with the clutch ground ring terminal fastened to frame.
14. Insulate the end of remaining loose wire of new wiring harness with shrinkable tubing (not included).
15. Connect wiring harness connectors to pressure switches as shown in wiring diagram of figure 4.

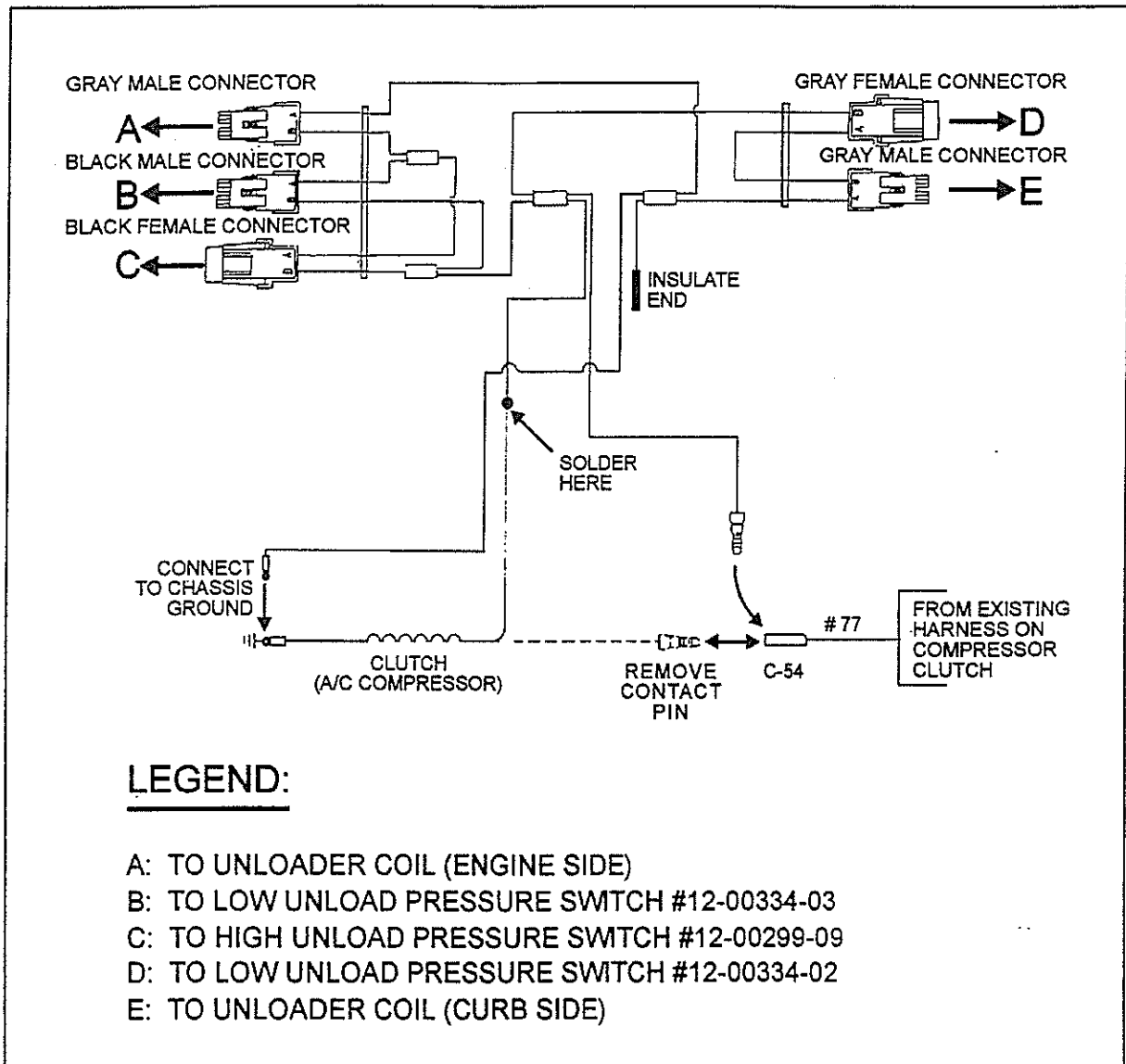

Fig. 4 - Wiring Harness #95-0250 Installation

INSTALLING A NEW COMPRESSOR

1. Remove existing compressor then install new one following procedure given in the maintenance manual.

Note: Before fixing new compressor assembly, connect new suction hose (#45-2555) to compressor; it will avoid the necessity to remove the suction service valve from compressor to connect the new suction hose.

2. Install high pressure switch (#45-2405) on "schrader" valve mounted on pressure side of compressor (one pressure switch is already mounted on this port).
3. Install low pressure switch (#45-2406) on "schrader" valve mounted on suction side of compressor (two pressure switches are already mounted on this port).
4. Perform steps #8-9-10 described under previous heading "A/C Compressor Retrofitting".
5. Identify on new compressor, the white wire provided with a male contact pin, then connect to connector C-54.
6. Identify on new compressor, the second white wire (the latter has no terminal), crimp a ring terminal (not included) then connect to the vehicle frame.

MODIFICATION IN CONDENSER COMPARTMENT

1. Remove the caps (only) from the gauge adapter fittings on the receiver tank inlet and outlet valves. Replace each of the caps with new gauge adapter fittings and caps (red) #95-0234.
2. Remove the pressure relief valve (350 psi) from receiver tank then install new pressure relief valve (450 psi) #87-0890.
3. Disconnect inlet and outlet hoses from filter drier assembly.
4. Remove hose clamp and its bracket retaining filter drier outlet pipe to wall, retain screws but discard clamp and bracket.
5. Remove clamp retaining filter drier bottle to wall, retain screws but discard clamp.
6. Position new filter drier support (#45-2547) on condenser compartment R.H. wall, as illustrated in figure 5, then using filter drier support as a template, mark location of the four holes to be drilled.
7. Drill the four holes using a 1/8" (3 mm) bit, then mount support using the retained screws.
8. Position filter drier assembly (#45-2524), then secure filter drier bottle to support using two hose clamps (#50-4025) (refer to figure 6). Do not connect hoses.
9. Locate the "R-12" label affixed on receiver tank or on the condenser blower housing mounted under receiver tank, remove label, then place the new "R-134a" label (#37-3306).

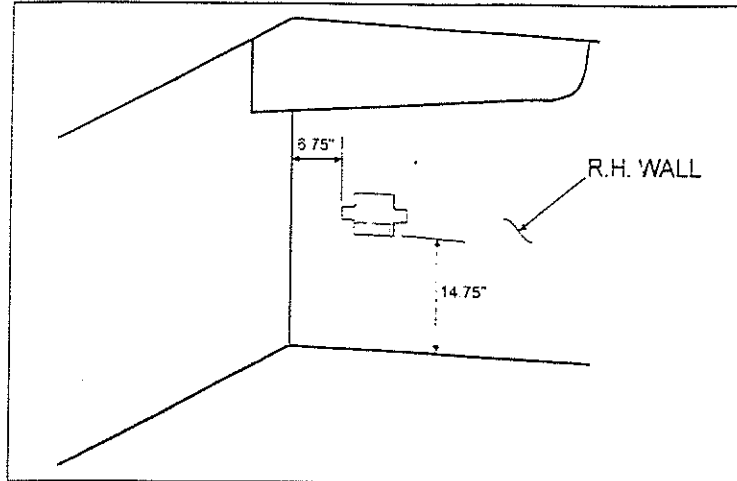

Fig. 5 - Filter Drier Support Installation

22010

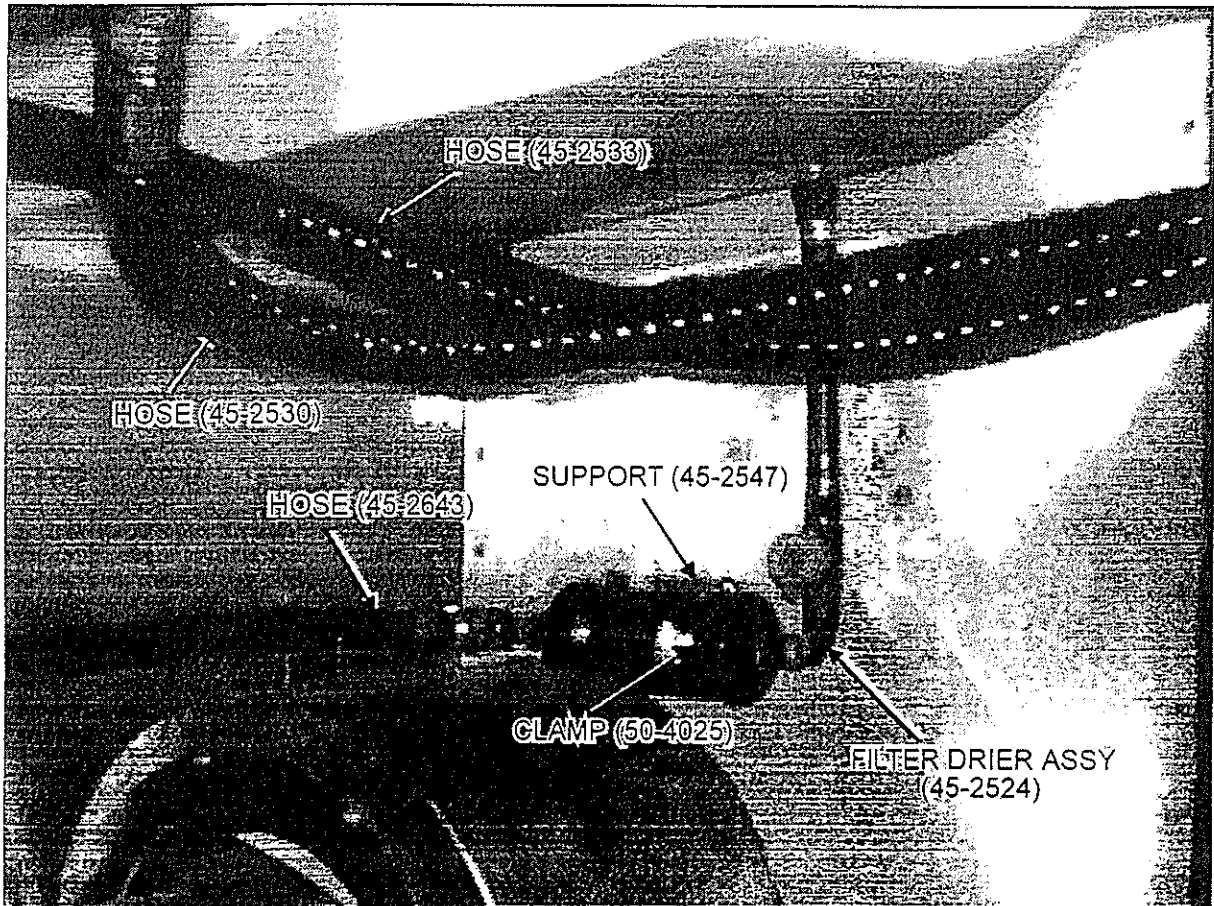

Fig. 6 - Modification in condenser compartment

22014 wpg

MODIFICATION IN EVAPORATOR COMPARTMENT

1. Open evaporator components' access panel located in baggage compartment forward of evaporator compartment, then locate the central expansion valve.
2. Trace the small coiled tubing of expansion valve up to caulking covering the remote bulb, then remove all caulking.
3. Loosen the straps retaining the remote bulb, then remove it.
4. Disconnect the equalizer line from expansion valve.
5. Disconnect the evaporator inlet hose from evaporator, then disconnect hose from expansion valve inlet.
6. Unbolt expansion valve from its bracket then remove expansion valve, hose and remote bulb as an assembly. Retain screws only.
7. Replace Evaporator Outlet hose. Replace the O-rings with the new O-rings from the kit. Refer to figure 7 for hose and O-ring identification and location.

Note: Lubricate the "O-rings" with white grease before installing.

8. Assemble new Evaporator Inlet hose (#45-2532) to the new expansion valve (#45-2540), then connect the hose other end to the evaporator. Do not connect existing hose to expansion valve inlet.

Note: Prevost recommends applying "Loctite" threadlocker #271 on male fittings' countersunk edge where the type of connection does not require an O-ring to ensure a sealed connection.

9. Secure expansion valve to bracket using the retained screws.
10. Connect equalizer line to expansion valve, then fix the remote bulb of new expansion valve to the evaporator suction line using the existing straps.

Note: The touching surface between the expansion valve bulb and suction line must be as clean and tight as possible to assure good heat transfer.

11. Apply caulking all around remote bulb.

HOSE REPLACEMENT

1. Replace the hoses in the condenser compartment. Replace the O-rings at the hose connections with the new O-rings from the kit. Refer to figure 7 for hose and O-ring identification and location.

Note: Lubricate the "O-rings" with white grease before installing.

Note: *Prevost recommends applying "Loctite" threadlocker #271 on male fittings' countersunk edge where the type of connection does not require an O-ring to ensure a sealed connection.*

2. Replace the large suction hose which is connected in condenser compartment at one end and in evaporator compartment at the other end. The hose connection in evaporator compartment is accessible by opening the evaporator air filter access panel mounted in last baggage compartment. The fuel tank access panel mounted in last baggage compartment must be removed to allow the removal of the suction hose.

Note: *Each time a locking tie is removed, do not forget to replace with a new one (not included) once the new hose has been installed.*

Note: *If a rubber boot is found damaged, discard it, and apply sufficient caulking around hose to ensure airtightness.*

3. Replace the discharge hose routed from filter drier to central expansion valve (both ends have already been disconnected). The fuel tank access panel mounted in baggage compartment forward of fuel tank must be removed to allow the removal of the discharge hose.

4. Replace the discharge hose routed from filter drier towards driver's evaporator. The connection with the copper line is accessible by removing the finishing panel at ceiling of baggage compartment located forward of condenser compartment.

5. Working now in driver's compartment, remove panel giving access to driver's HVAC unit.

6. Disconnect Evaporator Inlet and Outlet hoses from driver's expansion valve, then remove and discard expansion valve. Install new expansion valve #95-0221. Replace both O-rings. Refer to figure 7 for hose and O-ring identification.

7. Replace Evaporator Inlet and Outlet hoses with new hoses from the kit. One end of each hose is accessible from spare tire compartment.

Note: *Each time a locking tie is removed, do not forget to replace with a new one (not included) once the new hose has been installed.*

8. Replace hose connected to rear end of spare tire compartment and to driver's liquid solenoid valve.

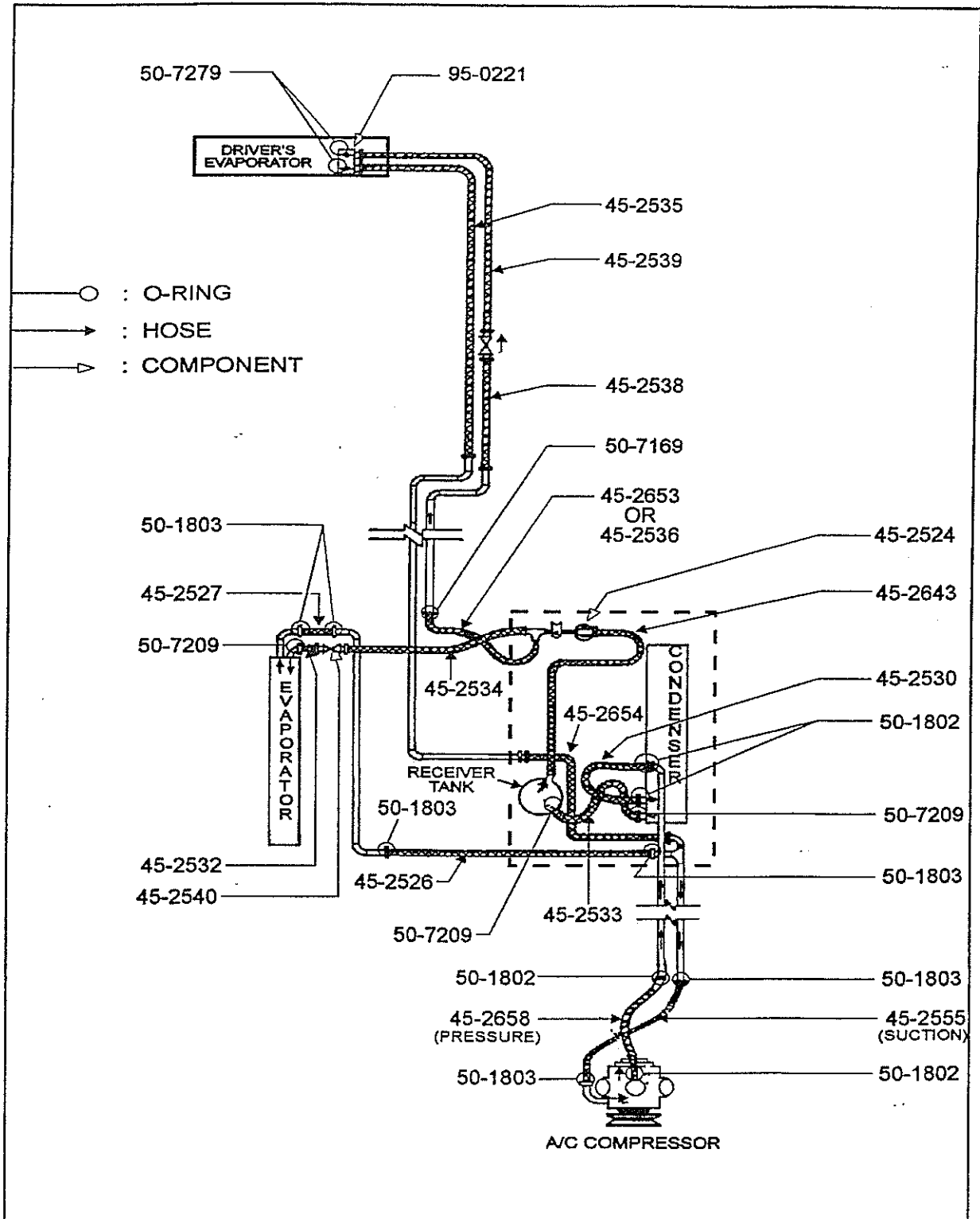

Fig. 7

220092

REFRIGERANT R134a CHARGING

1. Drain the oil out of the A/C compressor sump (for the last time) then refill with new "Ester-based" oil (approximately 4,0 liters). This last oil change is not necessary when a new compressor is installed.

Caution: *The repeat oil changes are necessary to ensure that contamination level of the mineral oil within the system is reduced to an acceptable level where it will no longer create a problem on conversion to R134a.*

2. Pump down the system below 2000 microns. Refer to "Pump Down Procedure" in the appropriate maintenance manual.

3. Charge the system at full charge using 24 lbs of R-134a refrigerant.

4. Leak test all connections following standard shop practices and procedures. Repair as needed.

Caution: *Make certain the leak detector being used is capable of properly detecting R-134a refrigerant. Many of the older detectors do not work for alternative refrigerants.*

5. Locate the "R-12" label affixed on support of engine air cleaner housing, remove, then place the new "R-134a" label (#37-3306).

SUPERHEAT VALUE ADJUSTMENT

The central expansion valve must be adjusted as follows:

1. Perform the following initial step with the system not running. Backseat the central expansion valve adjusting screw to release spring pressure, then screw in 11 1/2 turns clockwise.

2. Run the system and perform the final adjustment to obtain a superheat value of 10°F when the system is charged with R-134a refrigerant. Refer to appropriate maintenance manual for the procedure used to adjust superheat. The temperature and pressure data required to adjust superheat is given in Chart at the end. If the facility performing this retrofit is equipped with a superheat computer, the adjustment can be done following the instructions supplied with the computer.

Note: *Unlike the central expansion valve, the driver's expansion valve is not adjustable.*

3. Release the vehicle for service.

Caution: *The evaporator air filters must be regularly removed and cleaned to maintain efficient operation of the system.*

After one week of in-service operation, inspect the system paying special attention to the following items:

1. Check for leaks and repair as required.

-
2. Check that the refrigerant charge is at the proper level and adjust as needed.
 3. Make sure all access port caps are in place.
 4. Check the compressor oil level and adjust as required. The level should be in center of compressor sight glass with the system running, the compressor warm, and the system having been run for a minimum of 15 minutes before the level is checked.
 5. Examine the compressor oil for cleanliness and change the oil if it is discolored and/or dirty.

PROCEDURE COMPLETE

CHART ON THE FOLLOWING PAGE

HFC-134a			
TEMP °F	TEMP °C	VAPOR PRESSURE	
		INCHES OF MERCURY VACUUM	PSIG
-100	-73	27.8	
-90	-68	26.9	
-80	-62	25.6	
-70	-57	23.8	
-60	-51	21.5	
-50	-46	18.5	
-40	-40	14.7	
-30	-34	9.8	
-20	-29	3.8	
-10	-23		1.8
0	-18		6.3
10	-12		11.6
20	-7		18.0
30	-1		25.6
40	4		34.5
50	10		44.9
60	16		56.9
70	21		70.7
80	27		86.4
90	32		104.2
100	38		124.3
110	43		146.8
120	49		171.9
130	54		199.8
140	60		230.5
150	66		264.4
160	71		301.5
170	77		342.0
180	82		385.9
190	88		433.6
200	93		485.0
210	99		540.3