

**PREVOST**

ENREGISTRÉ - REGISTERED  
ISO 9001 & ISO 14001

**MAINTENANCE  
INFORMATION**

Mi02-16



DATE :	September 2003	SECTION :	23 - Accessories
SUBJECT :	SLIDE-OUT POSITION ADJUSTMENT		

**Important Notice:** This modification is recommended by Prévost Car to increase your vehicle's performance. Note that no reimbursement will be awarded for carrying out this modification.

**APPLICATION**

Model	VIN
XL2 MTH Model Year : 2000 - 2002	All XL2 MTH equipped with lateral slide-out(s)
H3 VIP Model Year : 2001 - 2003	All H3 VIP equipped with lateral slide-out(s)



**DESCRIPTION**

On the above-mentioned vehicles equipped with lateral slide-out(s), the slide-out(s) may have to be readjusted to ensure proper alignment of the locking pins. A load variation in the vehicle and/or slide-out (ex: after the conversion) may affect the structure deflection, therefore the locking pin adjustment, especially for the front slide-out.

**ADJUSTMENT PROCEDURE WITH FIRST GENERATION LOGIC CONTROLLER**

**Warning :** Park vehicle safely, apply parking brake, stop engine and set battery master switch(es) to the OFF position prior to working on the vehicle.

1. The slide-out must be retracted and all the pins unlocked for readjustment.
2. Identify the proper pneumatic valve controlling the locking pins of the problem slide-out (refer to figure 1).
3. Ensure the ignition key is in the "OFF" position. When the proper valve has been identified, insert a small screwdriver in the hole at the bottom of the nameplate and press firmly for 10 seconds, until all the pins are unlocked. During the process, you should hear a hissing sound, as the air flows to the locking pin cylinders.

**Caution:** To prevent any damage to the slide-out, unplug the air tubing located on the R.H. side (locking pin air pressure) above each slide-out locking pins air valve.

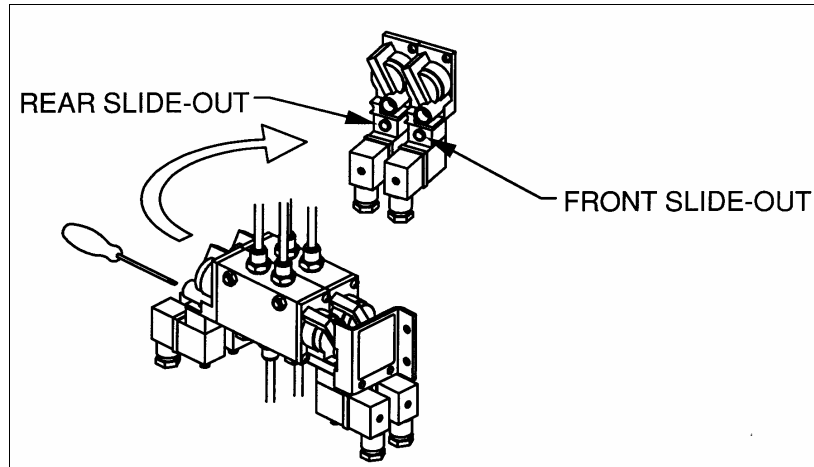

FIGURE 1

4. Verify if all the pins are unlocked. To do so, check the lights on the slide-out pin state indicator module with the ignition in the "on" position (see figure 2). The "ALL PINS UNLOCKED" red light must be "ON", on both slide-out. If one or both lights are off, verify which pins are not unlocked (red lights outside both rectangles) and go back to step number 3 to manually unlock all the pins until both lights "ALL PINS UNLOCKED" go "on".. (refer to slide-out operation manual).

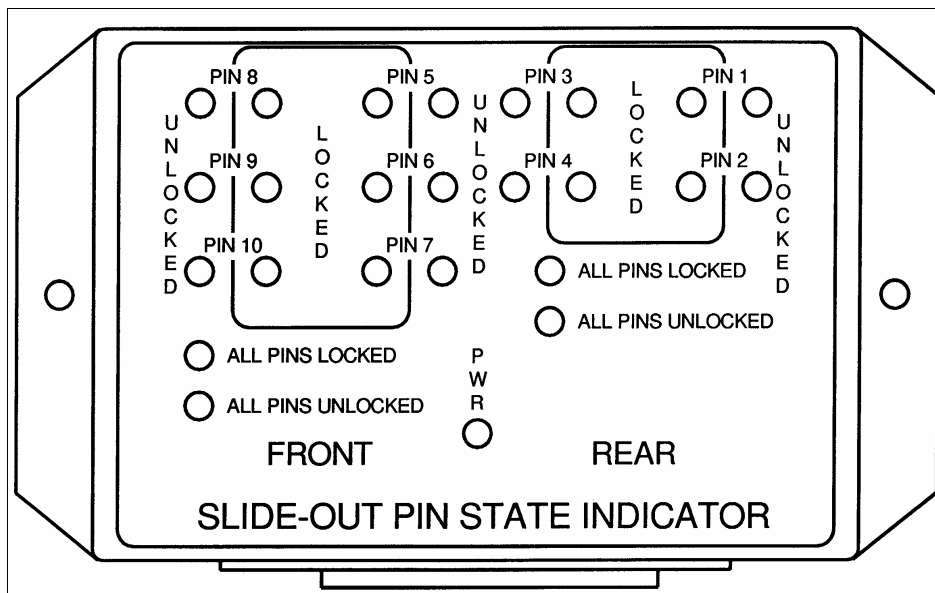

FIGURE 2

5. Ensure the ignition key is in the "OFF" position.
6. Remove any equipment or finishing material preventing access to the adjustable shaft assembly.
7. A torque must be applied on the upper shaft to compensate the effect of the center of gravity of the slide-out when inside the vehicle. This gravity effect causes the slide-out to fall down inside the vehicle. The torque applied on the shaft forces the pinions to push the upper part of the slide-out outside the vehicle to counterbalance the gravity effect.

**Note :** A considerable amount of force may have to be applied on the upper shaft to move the slide-out.

8. Operate the slide-out and check if the exterior panels of the slide-out are parallel with the vehicle panels. If not, rotate the upper part of the adjustable shaft assembly as required to obtain proper alignment (refer to figure 3).

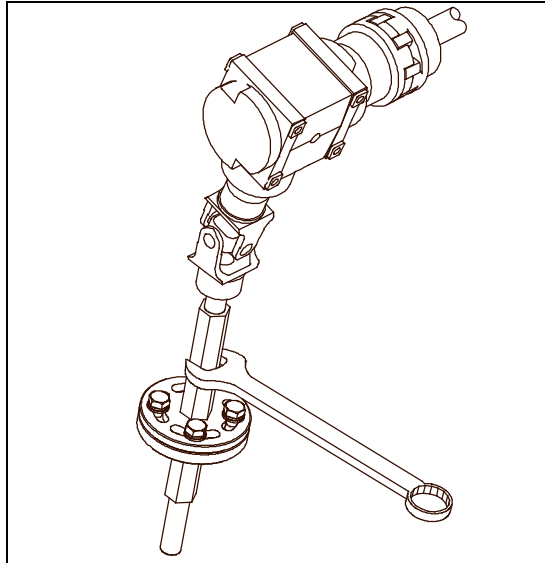

FIGURE 3

**Caution:** Make sure the adjustable shaft bolts are tightened to 25 lb-ft to insure that the adjustable shaft assembly is properly locked.

9. Once the slide-out is parallel to the vehicle panels, it may have to be extended or retracted to be lined up with the vehicle exterior.
10. If the slide-out is not lined up with the vehicle exterior, move the slide-out using a ½" socket on the back of the slide-out motor (refer to figure 4).

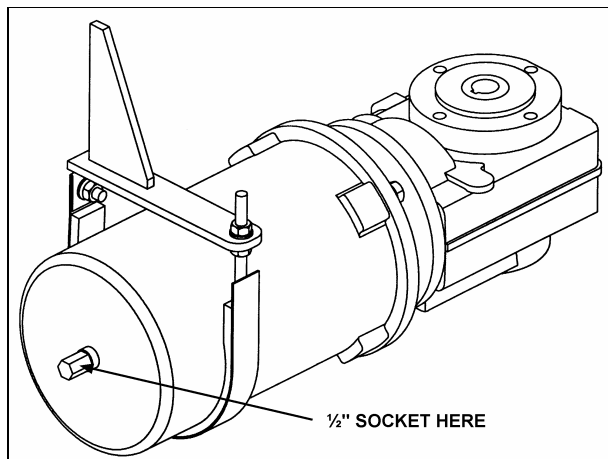

FIGURE 4

### SLIDE-OUT LIMITS SET-UP

**Caution:** Always set-up one slide-out at a time to prevent rear and front slide-out controllers mistaken.

1. Deflate the inflatable seal completely to prevent any damage.
2. Retract both slide-out to prevent any errors and ensure pins are locked.
3. Turn the ignition key to the "ON" position without starting the engine.

**Caution: Caution:** To prevent any damage to the slide-out, unplug the air tubing located on the R.H. side (locking pin air pressure) above each slide-out locking pins air valve.

4. Memorize the slide-out inner limit by pushing once the logic controller black push-button. The green LED "OUT6" confirms that the stroke limit is set in the logic controller memory (refer to figure 5).

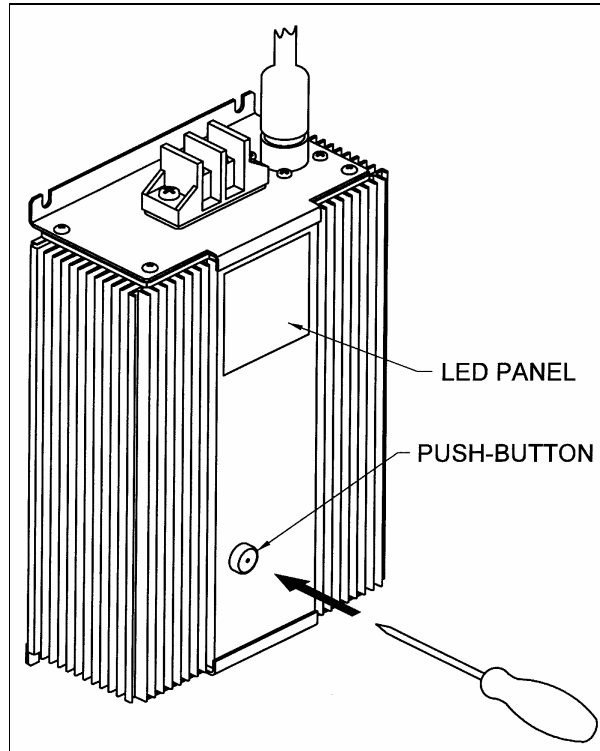

FIGURE 5

5. Using the manual override procedure, extend the slide-out completely until the slide-out reaches the inner stoppers.
6. Memorize the slide-out outer limit by pushing once on the logic controller black push-button. The green LED "OUT6" confirms that the stroke limit is set in the logic controller memory (refer to figure 5).
7. Using the slide-out control switch, retract the slide-out completely in, keeping depressed the slide-out control switch button. The air will flow out from the locking pins valve fitting.
8. **For the rear slide-out only:** Check if the rear slide-out set-up is correct after the stroke limits set-up. The rear slide-out should move after the seal deflation (3 to 4 seconds), while the front slide-out moves after a 20 seconds delay for tag axle unloading. If there is any problem, run through the rear slide-out program set-up again.

**Note:** When the vehicle engine is running, the alternator produces a higher voltage resulting in a faster slide-out motor speed and could affect the precision of the final position. In addition, when the slide-out is loaded, its weight (inertia) may keep it from stopping right on the programmed limits. It may become necessary to adjust the limits slightly before the slide-out reaches its retracted position.

9. Run the engine and move the slide-out in and out a few times. Check if the slide-out exterior panels are perfectly aligned with the vehicle panels. To get more precision, readjust the slide-out limit by extending manually the slide-out (see slide-out operation manual).
10. When the limit adjustment is completed, manually lock the slide-out. Reconnect the two air tubes on the locking pin valve.
11. Reinflate the inflatable seal.
12. Run tests using the slide-out control switch (automatic cycle), to ensure proper operation.

## ADJUSTMENT PROCEDURE WITH SECOND GENERATION LOGIC CONTROLLER

**Warning :** Park vehicle safely, apply parking brake, stop engine and set battery master switch(es) to the OFF position prior to working on the vehicle.

1. The slide-out must be retracted and all the pins unlocked for readjustment.
2. Identify the proper pneumatic valve controlling the locking pins of the problem slide-out (refer to figure 6).
3. Ensure the ignition key is in the "OFF" position. When the proper valve has been identified, turn clockwise the "pin valve manual override screw" to unlock the pins. Keep the override screw in this position. During the process, you should hear a hissing sound, as the air flows to the locking pin cylinders.

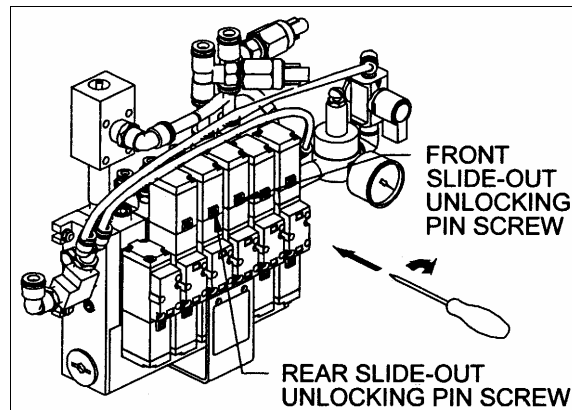

FIGURE 6

4. Verify if all the pins are unlocked with the ignition in the "ON" position. To do so, check the lights on the "PIN STATE INDICATOR" zone of the logic controller interface display. A light next to all unlocked padlocks is used to identify the unlocked state of the pins (refer to slide-out operation manual).
5. Remove any equipment or finishing material preventing access to the adjustable shaft assembly.
6. A torque must be applied on the upper shaft to compensate the effect of the center of gravity of the slide-out when inside the vehicle. This gravity effect causes the slide-out to fall down inside the vehicle. The torque applied on the shaft forces the pinions to push the upper part of the slide-out outside the vehicle to counterbalance the gravity effect.

**Note :** A considerable amount of force may have to be applied on the upper shaft to move the slide-out.

7. Operate the slide-out and check if the exterior panels of the slide-out are parallel with the vehicle panels. If not, rotate the upper part of the adjustable shaft assembly as required to obtain proper alignment (refer to figure 7).

**Caution:** Make sure the adjustable shaft bolts are tightened to 25 lb-ft to insure that the adjustable shaft assembly is properly locked.

8. Once the slide-out is parallel to the vehicle panels, it may have to be extended or retracted to be lined up with the vehicle exterior.

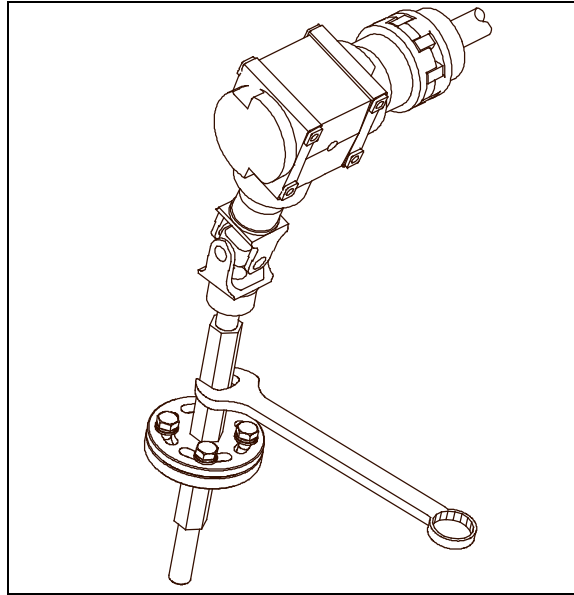

FIGURE 7

9. If the slide-out is not lined up with the vehicle exterior, move the slide-out using a ½" socket on the back of the slide-out motor (refer to figure 8).

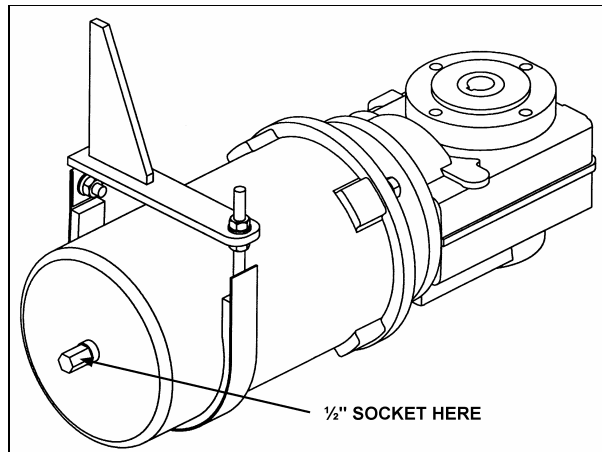

FIGURE 8

## INNER LIMIT SET-UP PROCEDURE

**Caution:** Always set-up one slide-out at a time to prevent rear and front slide-out controllers mistaken.

1. Deflate the inflatable seal completely to prevent any damage by using the relieving shut-off valve.
2. Retract and close both slide-out to prevent any errors.
3. Turn the ignition key to the "ON" position without starting the engine.

**Warning:** Actuating the locking pins on the slide-out not completely closed or with locking pins misaligned with their receptacle may result in glass breakage and cause serious injury.

4. Manually lock the pins using the pin valve manual override screw located on the upper section of the valve by turning it clockwise. Make sure to use the proper slide-out locking valve identified on the protection plate.
5. Remove the pressure in the locking pins by turning counterclockwise the manual override screw.

- Enter programming code by dialing the code **A C B D** on the slide-out logic controller. The diagnostic LED will turn ON.

**Note :** In programming mode, the slide-out cannot be moved by control switch. The locking pin valve is deactivated as soon as you enter this mode even if the slide-out is in closed position. The interlock valve is activated to ensure that the vehicle will not move because of the no-air pressure in the locking pins.

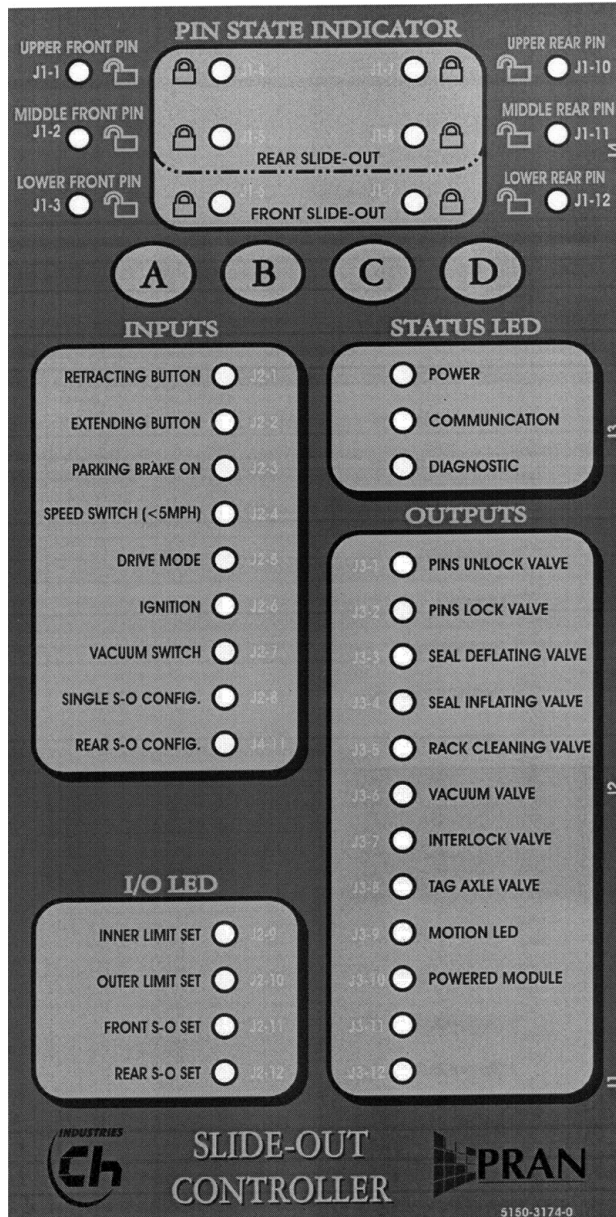

FIGURE 9

**Caution:** To prevent any damage to the slide-out, unplug the air tubing from the locking pins air valve.

- Memorize the slide-out inner limit by pushing and holding at the same time for at least two seconds the **A** and **D** buttons. The first two I/O LED of the logic controller will blink for confirmation.
- Press **D** button to check if the I/O LED will turn ON. Otherwise, repeat step 7.
- If the outer limit is set, exit programming mode by dialing the code **A C B D** and reinflate the inflatable seal. The diagnostic LED will turn OFF.

## OUTER LIMIT SET-UP PROCEDURE

1. Deflate the inflatable seal completely to prevent any damage by using the relieving shut-off valve.
2. Turn the ignition key to the "OFF" position.
3. Manually unlock the pins using the pin valve manual override screw located on the upper section of the valve by turning it clockwise. Let the manual override screw turned at this position during this procedure.
4. Make sure that all locking pins are unlocked.
5. Using the manual override procedure, extend the slide-out completely until the slide-out reaches the inner stoppers.
6. Turn the ignition key to the "ON" position without starting the engine.
7. Enter programming code by dialing the code **A C B D** on the slide-out logic controller. The diagnostic LED will turn ON.

**Note :** *In programming mode, the slide-out cannot be moved by control switch. The locking pin valve is deactivated as soon as you enter this mode even if the slide-out is in closed position. The interlock valve is activated to ensure that the vehicle will not move because of the no-air pressure in the locking pins.*

**Caution:** *To prevent any damage to the slide-out, unplug the air tubing from the locking pins air valve.*

8. Memorize the slide-out outer limit by pushing and holding at the same time for at least two seconds the **A** and **D** buttons. The first two I/O LED of the logic controller will blink for confirmation.
9. Press **D** button to check if the I/O LED will turn ON. Otherwise, repeat step 8.
10. Exit programming mode by dialing the code **A C B D**. The diagnostic LED will turn OFF.
11. Deactivate the unlocking pins valve by turning the manual override screw counterclockwise.
12. Reconnect the air tube on the locking pin valve and reinflate the inflatable seal.
13. Run tests using the slide-out control switch (automatic cycle) to ensure proper operation..

### Waste disposal :

Discard according to applicable environmental regulations (Municipal/State[Prov.]/ Federal)