



PREVOST

ENREGISTRÉ - REGISTERED
ISO 9001 & ISO 14001

SAFETY RECALL

Sr09-10



DATE : JUNE 2009	SECTION : 14-STEERING
SUBJECT : INSPECTION AND REPLACEMENT OF DRAG LINK SPHERICAL PLAIN BEARING ROD END	

APPLICATION

PRÉVOST INC. has determined that a defect which relates to motor vehicle safety exists in certain drag link assembly (Prevost #160959) or rod end assembly (Prevost #610991) sold to you by our aftermarket division.

DESCRIPTION

On items affected by this recall, material that may not meet Dana requirements for installation on the steering linkage of I-beam axle equipped vehicles have been purchased by you via Prevost Parts. Drag link end opening being off-centered, this can reduce the wall thickness below tolerances.

In certain heavy loading conditions this defective part could break, resulting in a loss of steering control which could result in a crash. Inspect inventory parts and parts already installed if applicable. If measurement is outside tolerances, part must be replaced and returned for reimbursement.

For more information on this recall or technical assistance on how to perform this safety recall, please contact your service manager or the nearest service center.

MATERIAL

Part No.	Description	Qty
610991	Drag Link Spherical Plain Bearing Rod End	1
502104	Pin, Cotter 5/32 x 2	1
169159	Go/no-go gauge	1

NOTE

Material can be obtained through regular channels.

PROCEDURE



DANGER

Park vehicle safely, apply parking brake, stop engine and set battery master switch(es) to the OFF position prior to working on the vehicle.

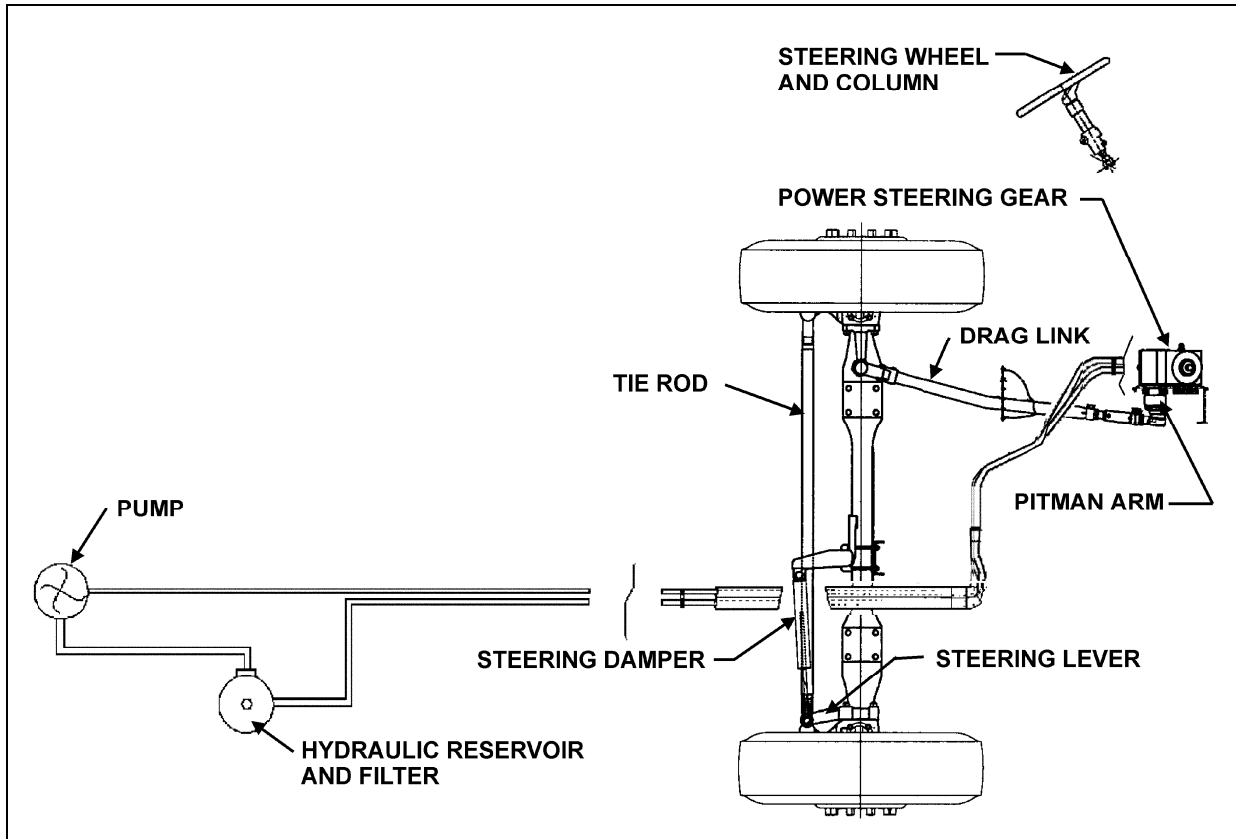

FIGURE 1

PART A: INSPECTION OF INVENTORY PARTS

Inspect inventory parts ideally using a vernier caliper or an outside caliper and steel ruler (Refer to figure 2).



FIGURE 2

PART B: INSPECTION OF PARTS ALREADY INSTALLED

1. Raise vehicle in order to inspect already installed parts.
2. Clean drag link surface near the rod end and also spherical plain bearing rod end to ensure proper measurements (Refer to figure 3)
3. Use supplied go/no-go gauge (169159) to check wall thickness of the drag link spherical plain bearing rod end located near front L.H. side wheel without having to remove drag link. **Minimum wall thickness is 4 mm (0.158 inch or 5/32")**. While resting go/no-go gauge against drag link, if you can get the gauge completely on the rod end up to 10 mm (3/8") from the rod end extremity, rod end must be replaced (Refer to figures 3, 4 and 5).

NOTE
<i>Control thin sections of rod end.</i>

4. If measurement is outside tolerances, part 610991 must be replaced.



FIGURE 3

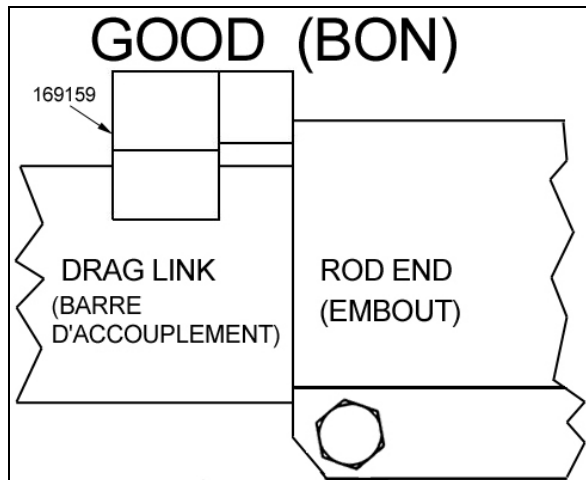

FIGURE 4

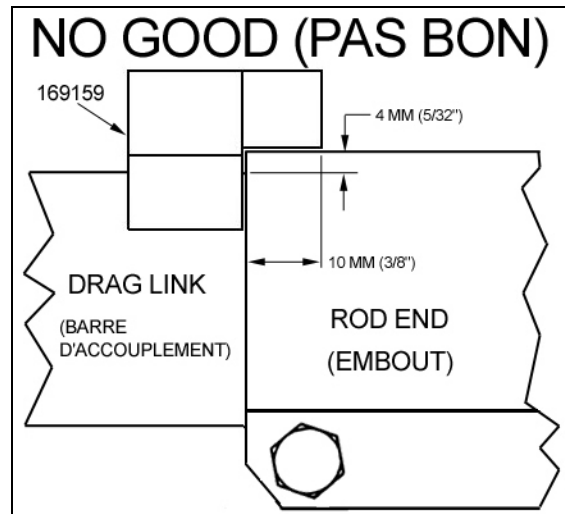

FIGURE 5

PART C: REPLACEMENT

1. At drag link spherical plain bearing rod end remove cotter pin from castle nut then remove castle nut.
2. Separate L.H. steering arm from ball joint.
3. Unfasten two pinching bolts from drag link end.
4. Unfasten drag link end from drag link (Refer to figure 6).

NOTE

Count number of turns to unfasten drag link end from drag link to facilitate future installation.

5. Install new drag link end (610991). Fasten drag link end onto drag link the same number of turns as previously removed.

NOTE

Prior to new drag link end installation, apply some anti-seize (680335) into the rod end opening and onto drag link threads to facilitate future removal.

6. Reconnect steering arm to ball joint, torque tighten castle nut to 150-200 lb-ft dry.
7. Install new cotter pin (502104).
8. Torque tighten two drag link end pinching bolts to 65-75 Lb-Ft dry.

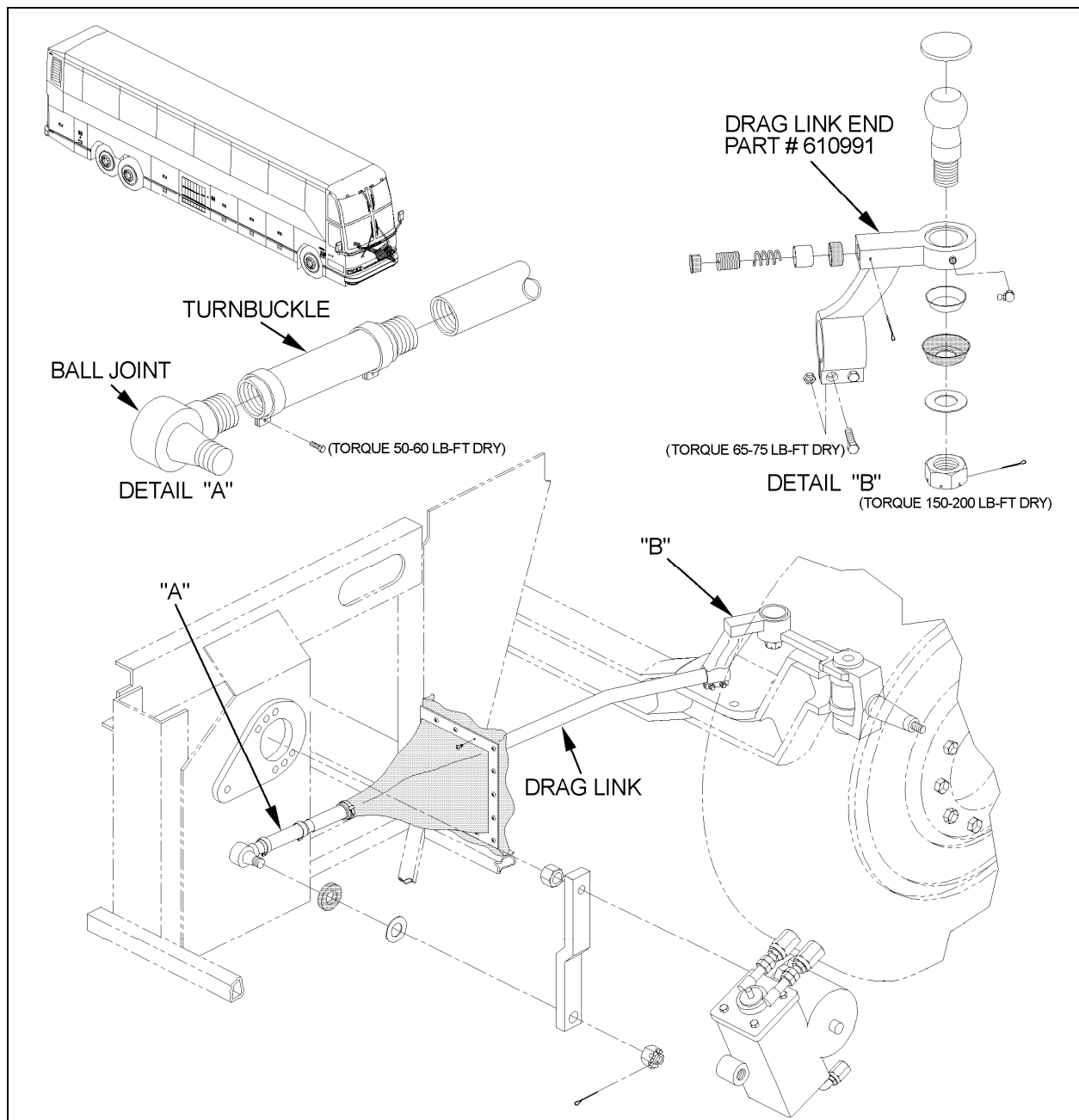

FIGURE 6

ADJUSTMENT

The front axle wheels facing forward and the steering gearbox being centered on reference mark, ensure that steering wheel is also centered.

If this is not the case, unfasten turnbuckle collar nuts on drag link and turn turnbuckle in order to center steering wheel. Retighten collar nuts to 50-60 Lb-Ft dry (Refer to figure 6).



CAUTION

To prevent interference when reaching maximum steer angle, make sure to properly reposition turnbuckle collars.

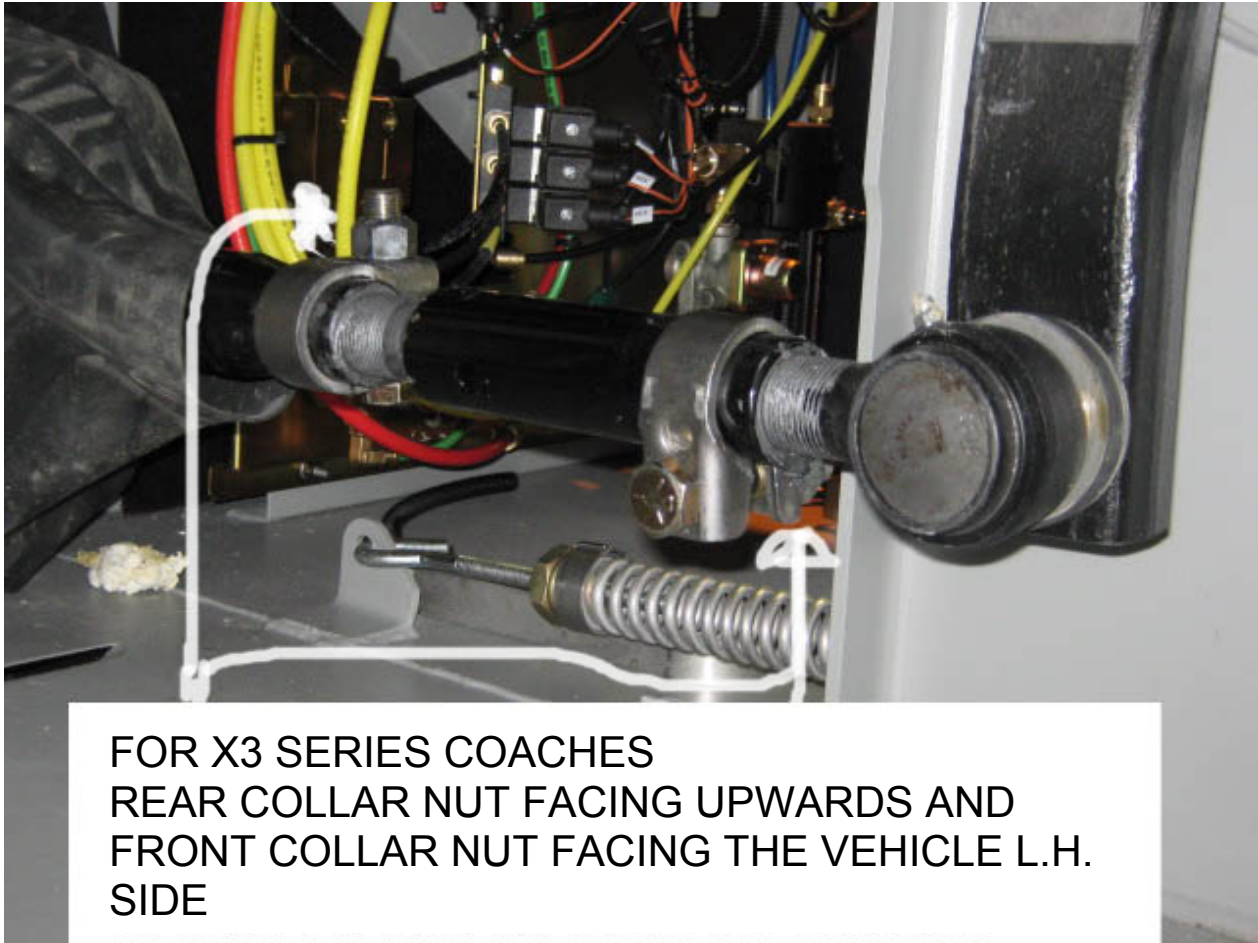

FOR X3 SERIES COACHES
REAR COLLAR NUT FACING UPWARDS AND
FRONT COLLAR NUT FACING THE VEHICLE L.H.
SIDE



FOR H SERIES COACHES
TWO COLLAR NUTS MUST
FACE UPWARDS

WARRANTY

PART C – REPLACEMENT

We will reimburse you the parts and **two and a half hours (2.5) of labor per replaced rod end** upon receipt of the replaced parts and a completed A.F.A. form on which you must specify as per "Safety Recall 09-10". **You also have to fill the "Safety Recall Certification Sheet" provided with this bulletin, indicate the applicable vehicle identification number (VIN) and return it with your A.F.A. form to be reimbursed.**

Parts / Waste disposal:

Return replaced parts to Prevost with A.F.A. for full reimbursement.

Reimbursement is subject to parts inspection by Prevost.



PREVOST

**Safety Recall
Certification Sheet
(Ref: Sr09-10)**

ENREGISTRÉ - REGISTERED
ISO 9001 & ISO 14001



VEHICLE SERIAL NUMBER: _____

PERFORMED BY		OWNER/OPERATOR	
We hereby certify that Safety Recall Instructions with regard to Safety Recall #09-10 have been performed.			
Name: _____		Name: _____	
Addr: _____		Addr: _____	
Phone: _____		Phone: _____	
Fax: _____		Fax: _____	
Signature :	_____	Signature :	_____
Date:	_____	Date:	_____

If the information mentioned above is incorrect or you are not the owner of this vehicle anymore, please fill this section and return to sender.

NEW OWNER: _____

BUSINESS: _____

ADDRESS (including County): _____

TELEPHONE: _____ **FAX:** _____

**Please return this completed document with your
A.F.A. form**