

**PREVOST**

**WARRANTY  
BULLETIN**

**WB13-04A**

DATE :	FEBRUARY 2013	SECTION :	22 - HVAC
EXPIRATION:	FEBRUARY 2015		
SUBJECT :	LOW A/C PRESSURE MESSAGE - BYPASS ADDITION, SMALL AC SYSTEMS ON H3 VIP		

REVISION :A THIS WARRANTY BULLETIN SUPERCEDES PREVIOUS VERSIONS  
Material: added "other parts that may be required", step 1: piping arrangement check.

**APPLICATION**

**NOTICE TO SERVICE CENTERS**

*Verify vehicle eligibility by checking warranty bulletin status with **SAP** or **Vehicle Warranty Information** tool found on Prevost–Systems tab of the Volvo Trucks Dealer Portal*

Model	VIN
H3-45 VIP Shells with small A/C system Model Year : 2011 - 2013	From 2PCVS3491 <u>BC711712</u> up to 2PCVS3494 <u>DC712280</u> incl.

This bulletin does not necessarily apply to all the above-mentioned vehicles, some vehicles may have been modified before delivery. The owners of the vehicles affected by this bulletin will be advised by a letter indicating the Vehicle Identification Number (VIN) of each vehicle concerned.

**DESCRIPTION**

On the vehicles affected by this bulletin, there may be an A/C Low Pressure message in the dashboard when the auxiliary fan is not running. Adding a bypass piping and valve assembly will solve this issue.

**MATERIAL**

Order kit #454749 which includes the following parts:

Part No.	Description	Qty
454748	Welded bypass tube assembly R899	1
507343	O-ring	1

Other parts that may be required

Part No.	Description	Qty
459203P	Low pressure tube assembly	1

## PROCEDURE



### DANGER

Park vehicle safely, apply parking brake, stop engine and set battery master switch(es) to the OFF position prior to working on the vehicle.



### WARNING

Protect your eyes and hands when handling refrigerant. Any liquid refrigerant which may accidentally escape is approximately -40°F (-40°C). If refrigerant comes in contact with the eyes or hands, serious injury could result. Always wear goggles and gloves when opening refrigerant connections.

1. Locate small A/C compressor in engine compartment, curb side.

*Note that some vehicles may show a different piping arrangement. You may have to order 459203P to have a compatible piping arrangement.*

2. Empty refrigerant from system piping using the service valves.

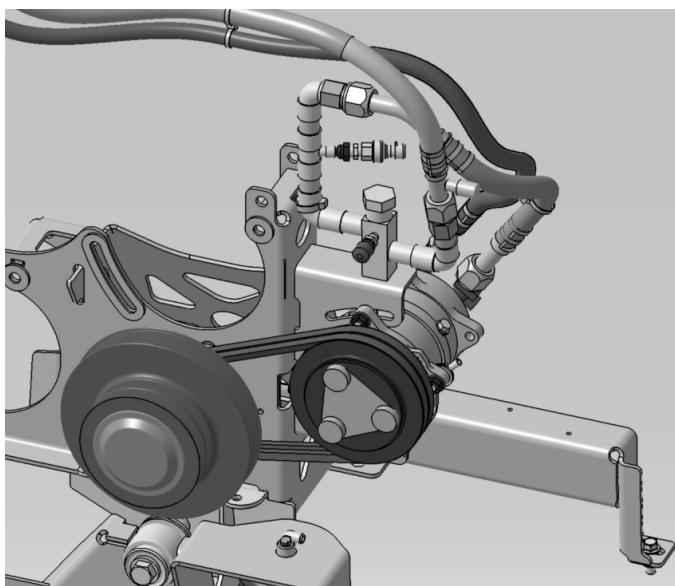

3. Disconnect high pressure hose from compressor.

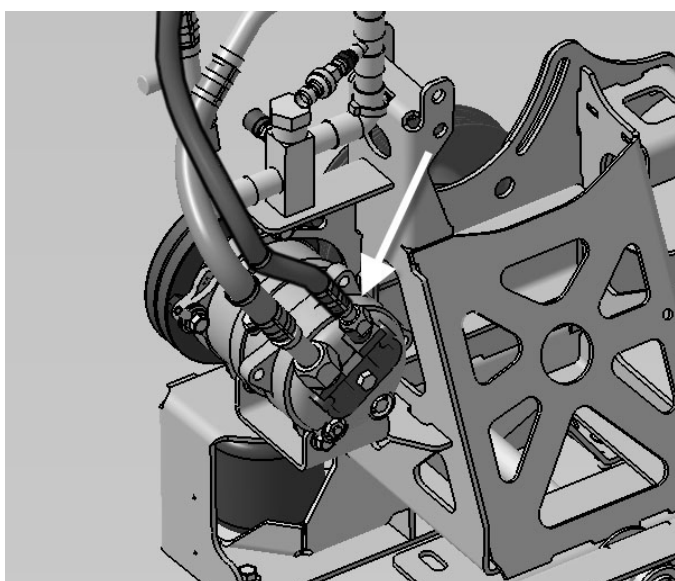

4. Disassemble Low pressure sensor.  
Keep for re-assembly.

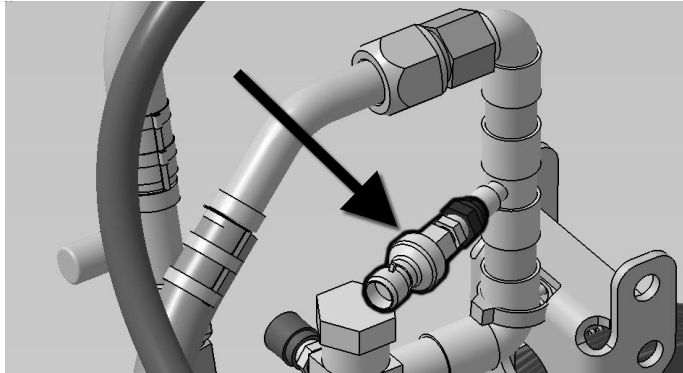

5. Add tee 501338 at arrow location  
between existing components.
6. Apply Loctite 567 thread sealant  
#680098 on all fitting connections

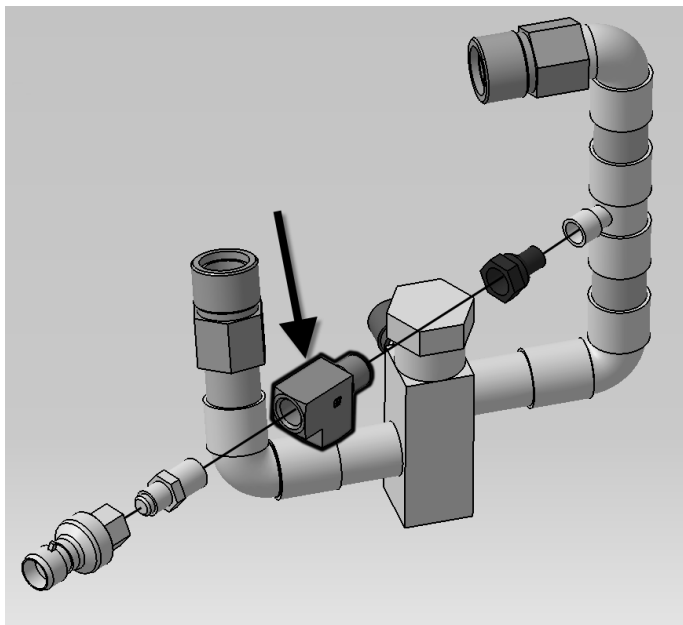

**Installing the bypass tube assembly.**



7. Install 5011082 tube compression fitting on the bare end of the bypass tube welded assembly.

Make sure the end is extra clean and free of burrs. In doubt use a fine "Scotch Brite" type scouring pad.

8. Install 5011080 ORS adapter between the compression fitting and the female Tee.

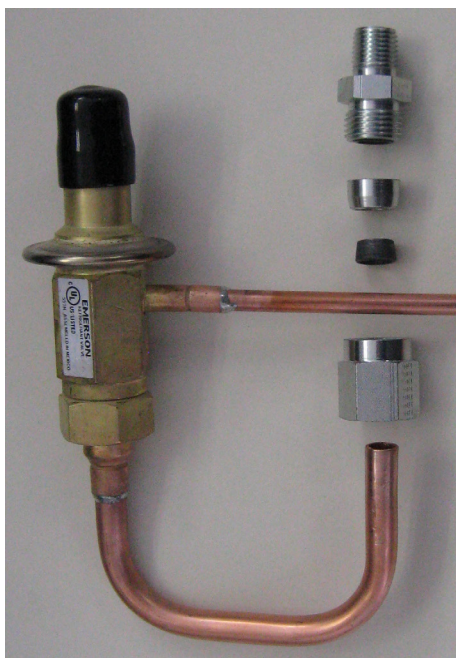

9. Connect female threaded fitting end of welded bypass tube assembly to compressor high pressure outlet. Use O-ring 507343.

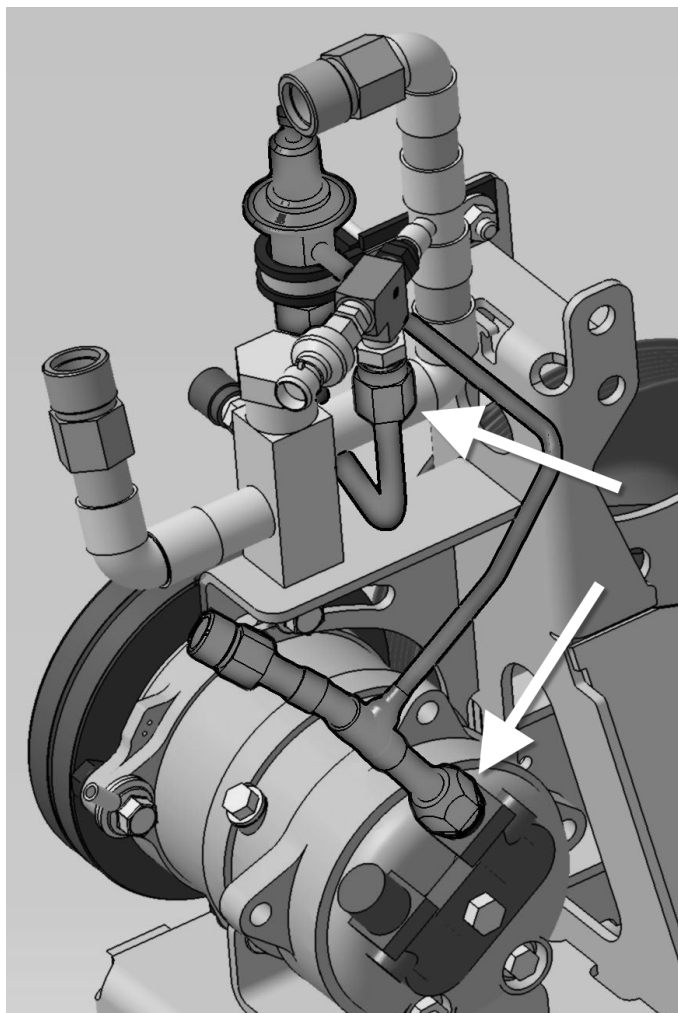

10. Connect high pressure hose to threaded fitting on bypass pipe.
11. Connect low pressure hose to compressor.

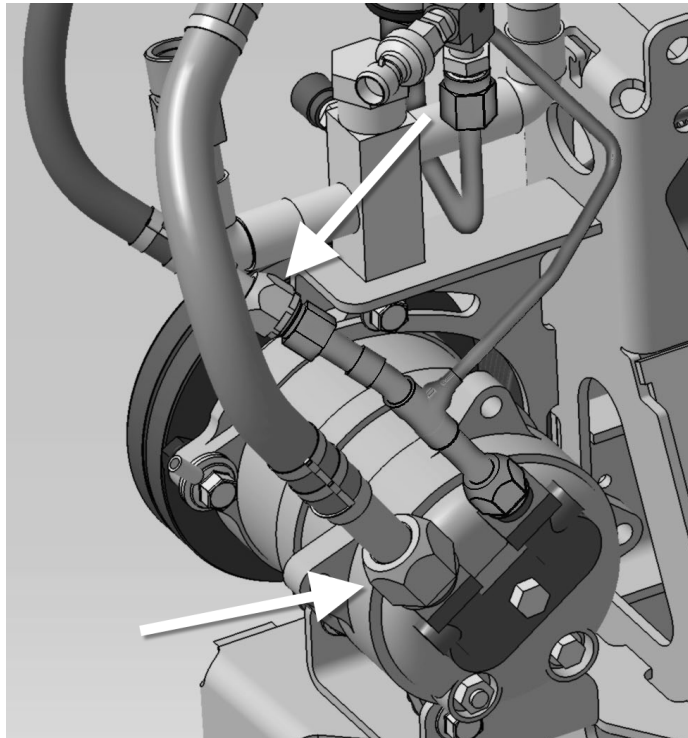

12. Support by-pass valve to alternator bracket with P-Clamp and provided hardware.  
Assemble clamp and support as shown.

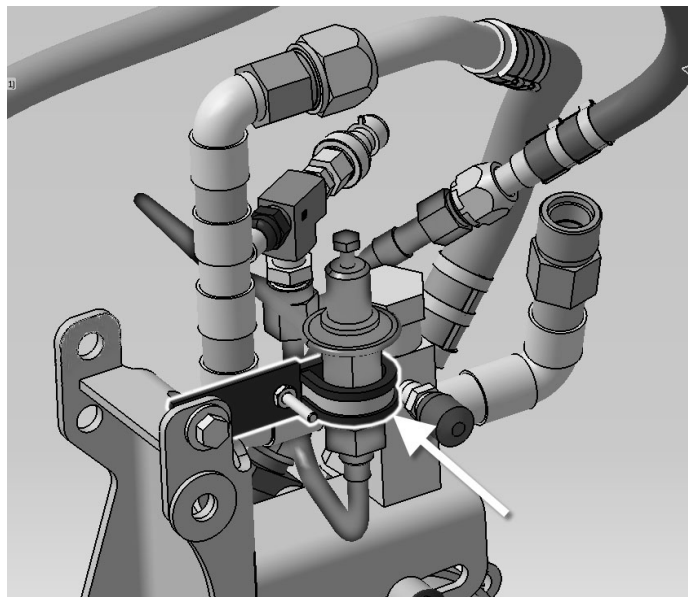
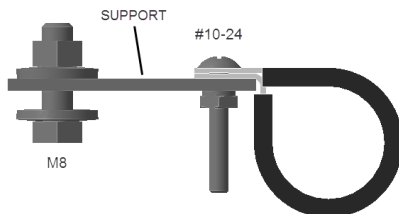

13. Pump refrigerant back in the system.  
Test A/C system for proper operation.

## PARTS / WASTE DISPOSAL

Discard waste according to applicable environmental regulations (Municipal/State[Prov.]/ Federal)

## WARRANTY

This modification is covered by Prevost's normal warranty. We will reimburse you three hours (3.0h) of labor upon receipt of a completed A.F.A. form on which you must specify "Warranty Bulletin WB13-04A".

## OTHER

VBC Bulletin	N/A
Fail Code	22.00
Defect Code	09
System Condition	B
Causal Part	459203

Access all our Service Bulletins on <http://prevostparts.volvo.com/technicalpublicatios/en/pub.asp>  
Or scan the QR-Code with your smart phone.

E-mail us at [technicalpublications\\_prev@volvo.com](mailto:technicalpublications_prev@volvo.com) and type "ADD" in the subject to receive our warranty bulletins by e-mail.

