

# PREVOST

## WARRANTY BULLETIN

**WB14-32**

DATE :	SEPTEMBER 2014	SECTION: 06- Electrical
EXPIRATION:	SEPTEMBER 2016	
SUBJECT :	MASTER RELAY CORROSION	

### APPLICATION

<b>NOTICE TO SERVICE CENTERS</b>	
<i>Verify vehicle eligibility by checking warranty bulletin status with <b>SAP</b> or via <b>ONLINE WARRANTY SYSTEM</b> available on Service / Warranty tab of Prevost website.</i>	
Model	VIN
X3-45 Coaches Model Year : 2010 - 2013	 Vehicles <u>2PCG33498AC729907</u> , <u>2PCG33491AC729926</u> , <u>2PCG33499BC729965</u> and From <u>2PCG33491BC735002</u> up to <u>2PCG33494DC735451</u> incl.
XLII-45 Entertainer Model Year : 2011 - 2013	From <u>2PCY33498BC735003</u> up to <u>2PCY3349XDC735457</u> incl.
X3-45 VIP motorhomes Model Year : 2012 - 2013	From <u>2PCBS3499CC735070</u> up to <u>2PCBS3490DC735458</u> incl.
<b>This bulletin does not necessarily apply to all the above-mentioned vehicles, some vehicles may have been modified before delivery. The owners of the vehicles affected by this bulletin will be advised by a letter indicating the Vehicle Identification Number (VIN) of each vehicle concerned.</b>	

### DESCRIPTION

On the vehicles affected by this bulletin, it is possible to observe signs of corrosion at the base of the master relay installed in the vehicle battery box.

At the next service occasion, install a new relay along with shims between the relay mounting flange and the battery box bottom in a way that space is created between the relay base and the battery box bottom, preventing corrosion of the relay.

## MATERIAL

Order kit WB14-32 which include the following parts:

Part No.	Description	Qty
5001687	Screw, Hexagonal 1.25X30	3
5001869	Washer Flat SS 3/4" OD X 11/32" ID X 0.12	6
502847	Nut, Hexagonal NX500 M8-1.25 Gr8	3
562364	Master Relay	1

Other parts that may be required:

Part No.	Description	Qty
Generic	Fast setting rubber adhesive (Loctite 404 or equivalent)	1
506338	Rubber Trim	1.5ft (48cm)

### *NOTE*

*Material can be obtained through regular channels.*

## PROCEDURE



### **DANGER**

Park vehicle safely, apply parking brake, stop engine and set battery master switch(es) to the OFF position prior to working on the vehicle.

1. Remove both the electrical compartment cover and the battery box cover.

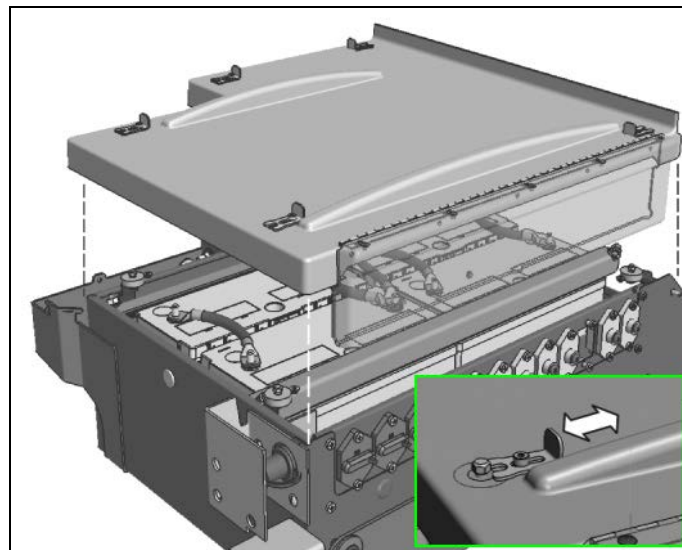

2. Disconnect the batteries.



## CAUTION

Double check that the battery master switch is set to the OFF position before disconnecting the batteries.

Batteries ground (negative) cables must be disconnected first and reconnected last.

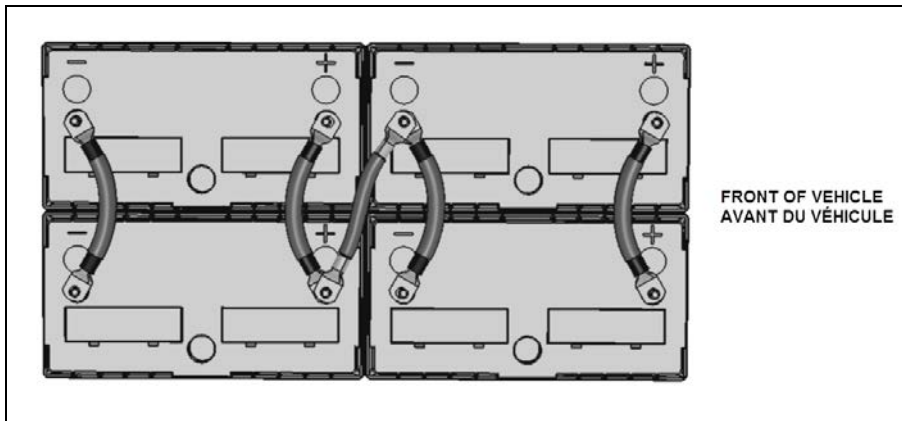

3. Unscrew the two hex nuts that hold the batteries rear retaining angle bar and remove the bar.

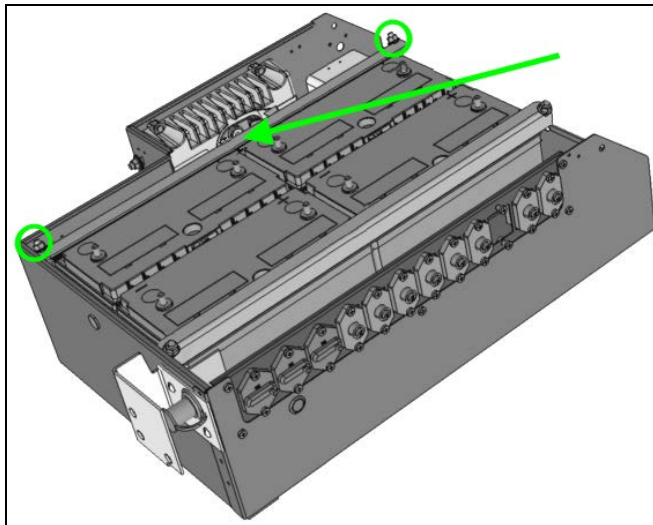

4. Remove the rear right battery from the battery box to gain access to the master relay.

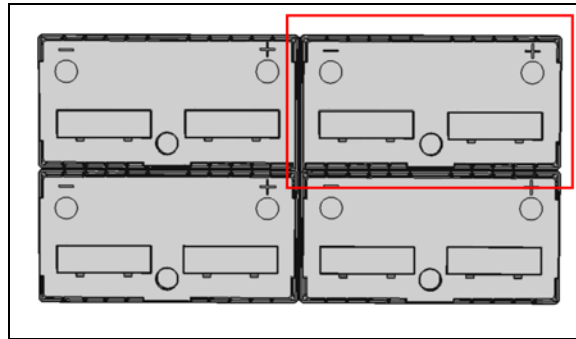

5. Locate the master relay fixed at the bottom of the rear corner in the battery box.



6. Remove the master relay cover to gain access to the connections at the top of the relay.

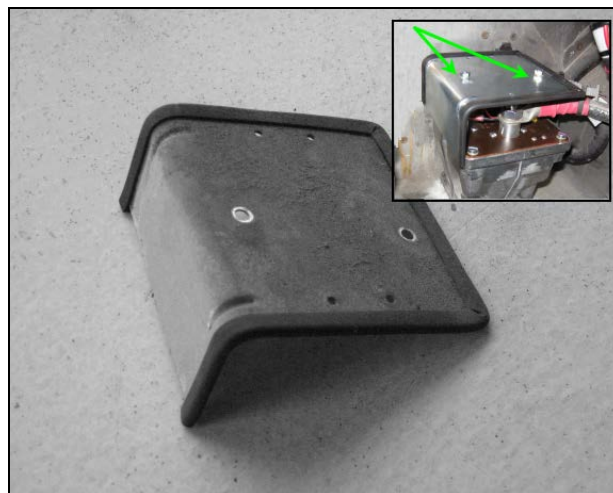

7. Disconnect the two (2) relay power connections hold by hex nuts.



8. Disconnect both secondary connections (two (2) flat head screws).

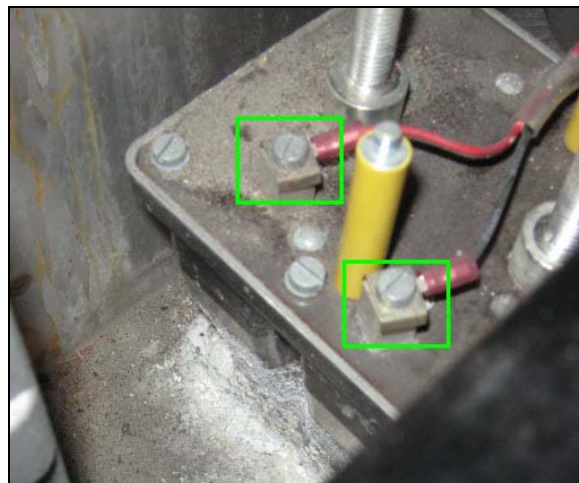

9. Unscrew the three (3) hexagonal bolts that hold the relay to the battery box bottom.





**NOTE**

If the hex bolts and nuts are severely attacked by corrosion, it may be necessary to cut the bolts heads from under the vehicle with a rotary cutting tool and suitable eye protection equipment.



10. Remove the relay from the vehicle.
11. Clean the bottom of the battery box and remove as much of the oxidation residues as possible. Use battery post cleaner as necessary.



12. With the help of an assistant, install the three (3) new 30mm bolts from under the vehicle and slide the six (6) stainless flat washers over the bolts threads in the battery box.

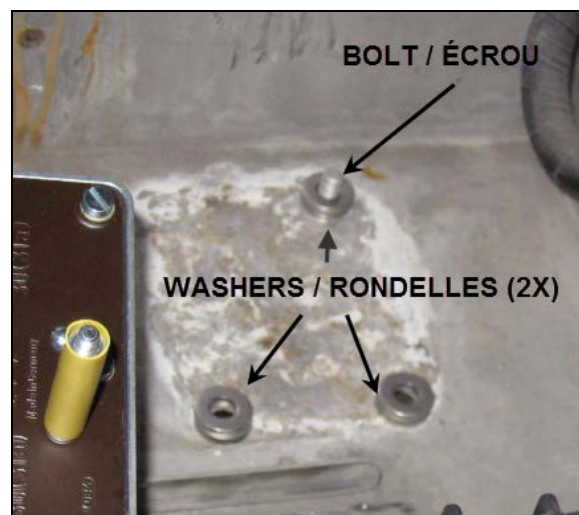

13. Remove the cover from the new relay and install the relay over the stainless washers. Hand tight the three (3) provided hex nuts.



14. Tighten the three (3) hex nuts to 16 ft-lb (22 Nm).

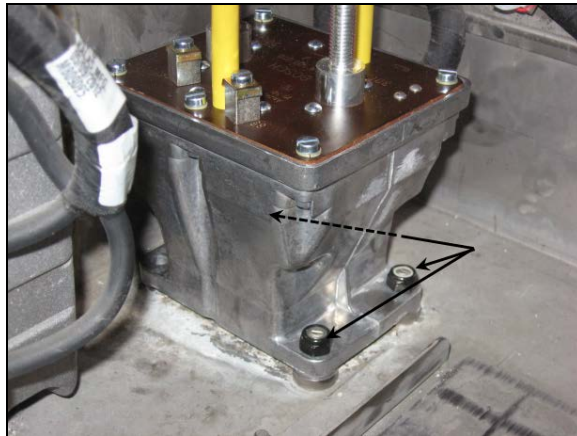

15. Reconnect the two (2) secondary wires at the top of the relay (flat head screws).

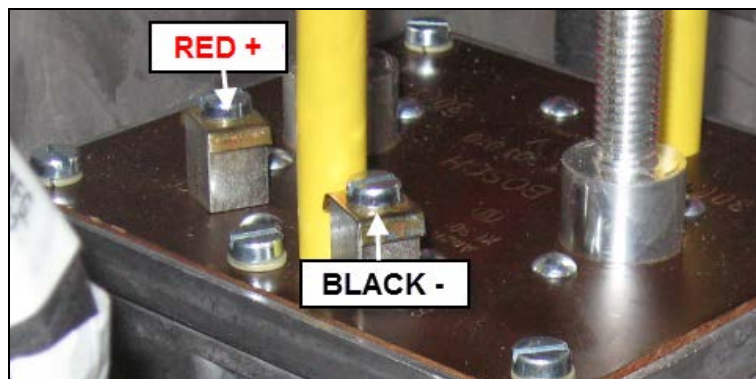

16. Reconnect the two (2) main relay power cables; tighten to 15 ft-lb (20 Nm).

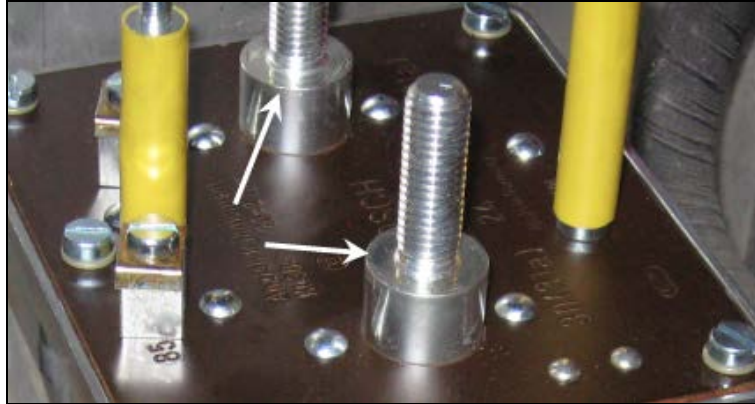

17. Remove the old relay cover trim, clean and put back on the new relay cover using fast drying adhesive (Loctite 404 or equivalent).

**NOTE**

*If the cover trim shows signs of deterioration or cannot be cleaned to allow correct adhesion, use 48cm (18in) of #56338 rubber trim to make a replacement.*



**CAUTION**

The rubber trim is used on the relay cover to protect the surrounding wires and cable from abrasion against the cover sharp edges, Installation of the trim on the new cover is not an optional step.

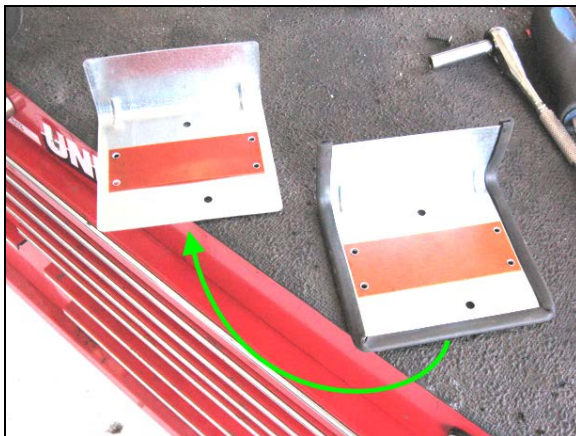



18. Using the two (2) hex nuts, install the cover on the relay.



19. Re-install the rear right battery in the battery box (negative post goes left positive one right as shown below)

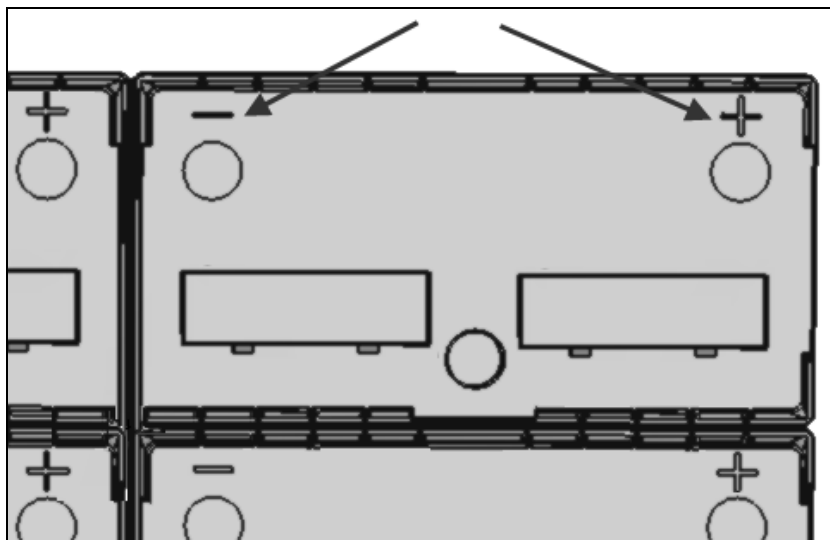

20. Re-install the back retaining angle bar.

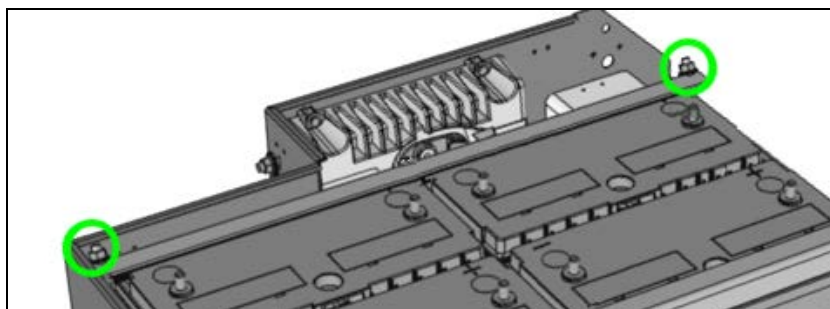

21. Reconnect the batteries following the drawing bellow, terminals must be torqued to 18-20Nm (13-15 ft-lb).



## CAUTION

To avoid damage to the vehicle electronic equipment, the positive (+) cables must be reconnected first.  
*Double check that the terminals are not reversed before connecting the cables.*

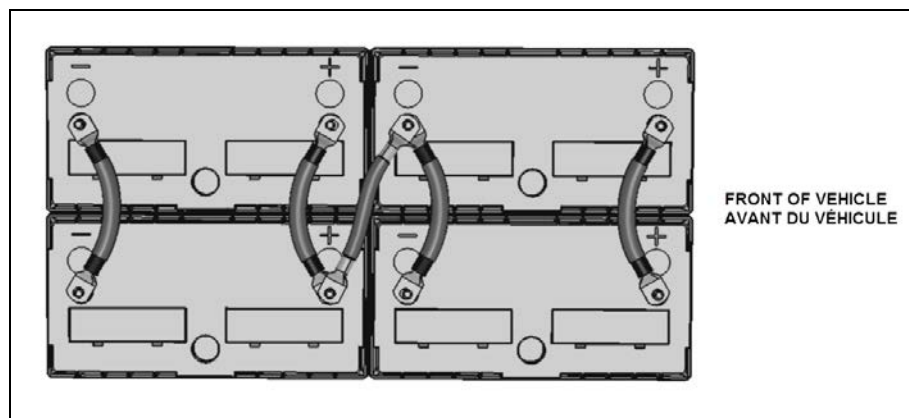
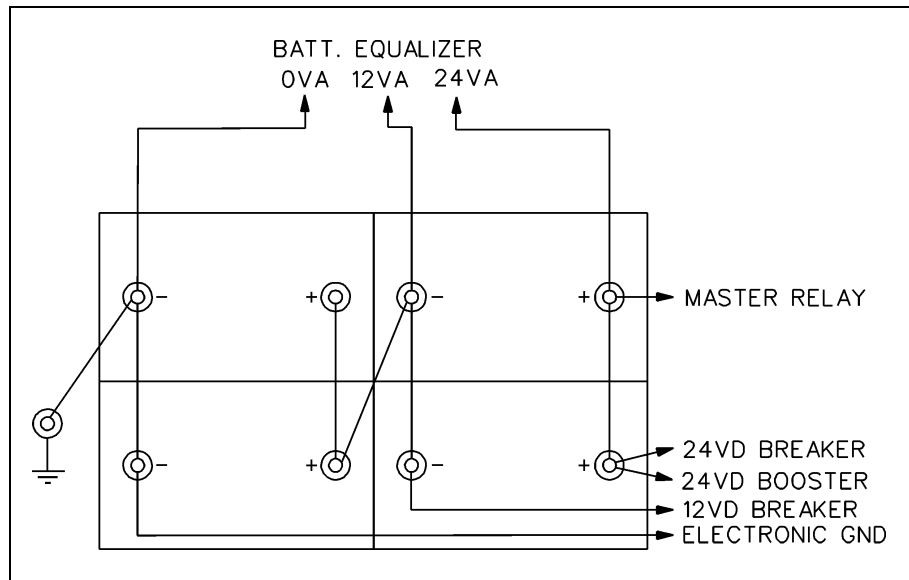

22. Set the battery master switch to the ON position and check for proper operation of the vehicle electrical system.

## PARTS / WASTE DISPOSAL

DO NOT RETURN THE REPLACED PARTS. Discard waste according to applicable environmental regulations (Municipal/State[Prov.]/ Federal)

## WARRANTY

This modification is covered by Prevo's normal warranty. We will reimburse you the parts and one hour (1.0) of labor upon receipt of a warranty claim. Please submit claim via our Online Warranty System, available at [www.prevo.com](http://www.prevo.com) (under Service \ Warranty section). Use Claim Type: "Bulletin/Recall" and select "Warranty Bulletin WB14-32".

## OTHER

VBC Bulletin	N/A
Fail Code	06.09
Defect Code	09
Syst.Cond.	B
Causal Part	562364

Access all our Service Bulletins on  
<http://prevostparts.volvo.com/technicalpublications/en/pub.asp>  
or scan the QR-Code with your smart phone.

E-mail us at [technicalpublications\\_prev@volvo.com](mailto:technicalpublications_prev@volvo.com) and type  
"ADD" in the subject to receive our warranty bulletins by e-mail.

