

PREVOST

Warranty Bulletin

95-10

Date: **April 1995**
Section: **16**
Subject: **Transversal and Longitudinal Radius Rod**
Application:

Model	VIN
H3-41 coach, H3-45 coach, and H3-45 VIP converted coach shell	All up to 2P9V33493S1001129 inclusively

DESCRIPTION

Prévost Car Inc engineering department has found that, on H3-41, H3-45 and H3-45 VIP vehicles, the protective coating applied on the subframe can form a cushion between subframe and radius rod support that, in extreme conditions, can lead to loosening of bolts. Therefore, you must dismantle these supports to remove the protective coating, as per the following procedure.

MATERIAL

Part no	Description	Qty
110340	Tab washer	5

PROCEDURE

Warning: Park vehicle safely, apply parking brake, stop engine and set battery master switch to the OFF position prior to working on the vehicle

Prior to working under a air-suspended vehicle, it is strongly recommended to support the body at the recommended jacking points.

For each of the 11 radius rod on your vehicle that are identified on figure 1, proceed as follows:

Warning: Because radius rod are very heavy, take care during removal procedures.

Type 1 Support (Fig. 1: A, B, D, E, F, G, H, J):

1. Unscrew the two bolts and nuts (on F and G support, one of the nut is accessible from last baggage compartment) retaining support on subframe.
2. Scrape off protective coating down to bare metal on both contacting surfaces (subframe and support).

Caution: Before tightening bolts and nuts, it is extremely important that the suspension of the vehicle is set to the proper driving height (see "maintenance manual"). Otherwise, the rubber bushing in radius rod ends will become preloaded, thus reducing the life of these parts.

3. Replace support, apply oil on threads of bolts, and torque bolts to 110-130 lbf•ft lubricated (150-175 N•m lubricated).

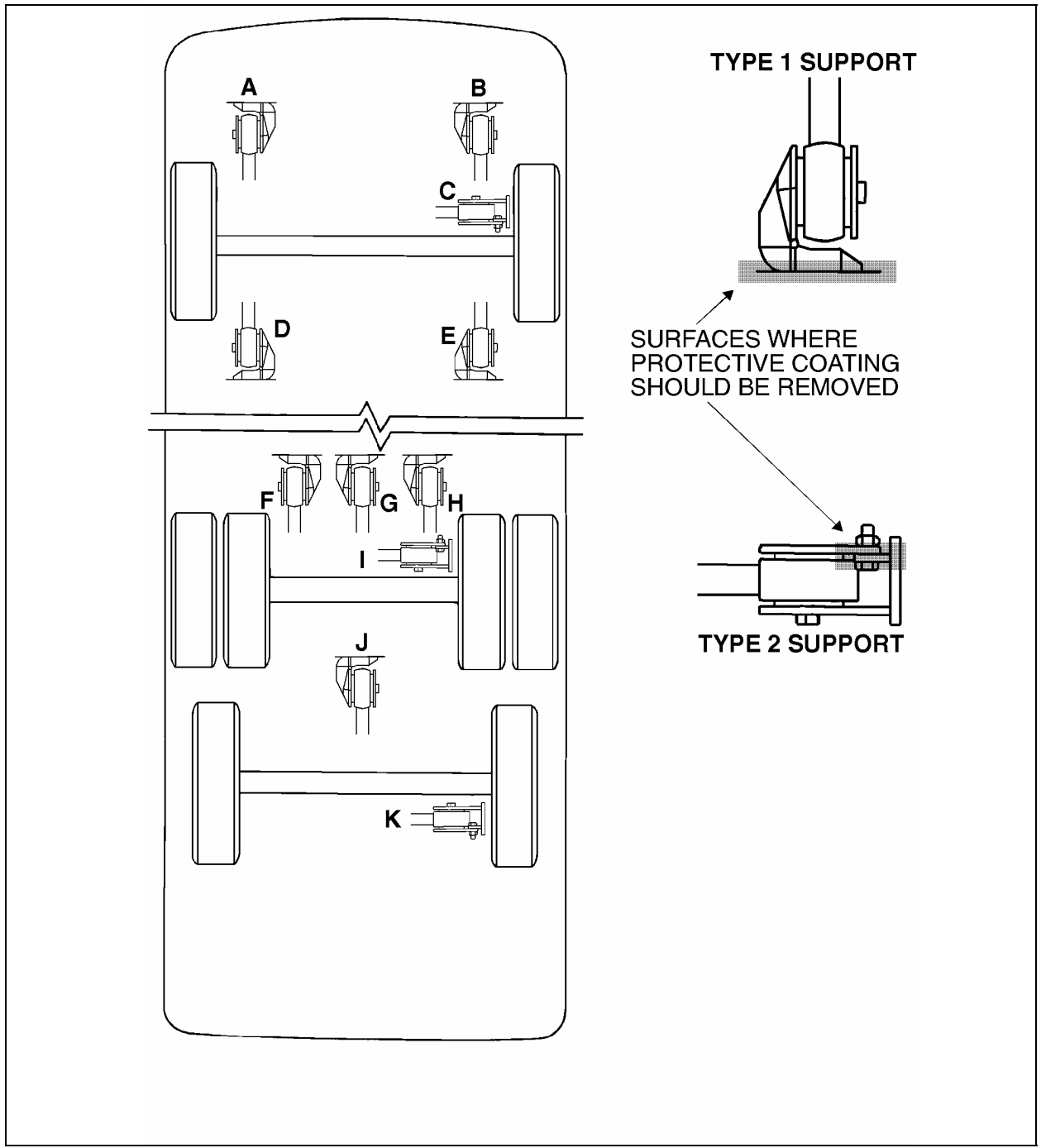

FIGURE 1

16024

Type 2 Support (Fig. 1: C, I, K):

1. Flatten tab washer and unscrew bolts. Unscrew the two bolts and nuts retaining radius rod support and remove radius rod.
2. Scrape off protective coating down to bare metal on both contacting surfaces (support and support on subframe (Fig. 2)).

Caution: Before tightening bolts and nuts, it is extremely important that the suspension of the vehicle is set to the proper driving height (see "maintenance manual"). Otherwise, the rubber bushing in radius rod ends will become preloaded, thus reducing the life of these parts.

3. Replace support, radius rod and a new tab washer, apply oil on threads of bolts, and torque bolts to 110-130 lbf•ft lubricated (150-175 N•m lubricated). Fold tab washer over nuts.

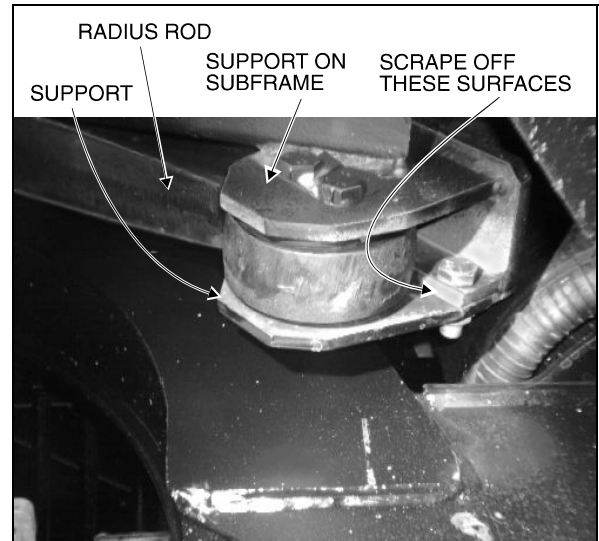

FIGURE 2

16025

WARRANTY

This modification is covered by the manufacturer's normal warranty. We will reimburse you the parts and six and a half hours (6.5) of labor upon receipt of a completed A.F.A. form on which you must specify as per "Warranty Bulletin 95-10".

Expiration date: April 1996