

PREVOST

ENREGISTRÉ - REGISTERED
ISO 9001 & ISO 14001

**WARRANTY
BULLETIN**

Wb98-30



DATE : October 1998	SECTION : 06 - Electrical
EXPIRATION : October 1999	
SUBJECT : ENGINE STARTING FAILURE	

APPLICATION

Model	VIN
H3-41, H3-45 Coaches and VIP-45 Model Year : 1997 - 1999	 From 2PCH3349XV1011779 up to 2PCH3349XX1012658 incl.

DESCRIPTION

On the above-mentioned vehicles, to improve the reliability of the ignition system, we are eliminating R11 & R8 relays and powering up the DDEC ECM (wire 439) and the transmission ECU (fuse F2) directly from CB21. CB21 will be energized from relay R2 via wire 12I. To do so, you need to order kit #064880.

MATERIAL

Kit # 064880 includes the following parts :

Part No.	Description	Qty
064870	Jumper cable assembly, Relay R8 and R11	1
561792	Circuit Breaker, CB 21 10A	1
504637	Cable tie	10

Note : Material can be obtained through regular channels.

PROCEDURE

Warning : Park vehicle safely, apply parking brake, stop engine and set battery master switch(es) to the OFF position prior to working on the vehicle.

1. Open battery compartment, locate the junction box on the battery compartment panel (refer to figure 1). Unfasten circuit breaker fixing block. Unfasten bus bar and CB 21 circuit breaker attaching screws (refer to figure 2). Tilt CB 21 circuit breaker upwards in order to remove.
2. Cut bus bar to be able to use it with two circuit breakers only. Move CB 19 and CB 20 circuit breakers to the right then reinstall fixing block. Connect 12W wires to bus bar terminals (refer to figure 3). Cut 440 wire previously connected to CB 21 circuit breaker.

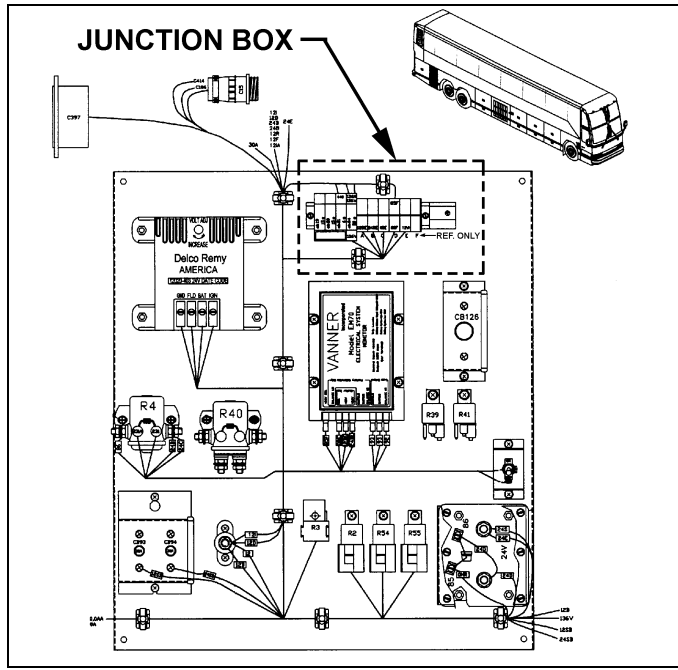

FIGURE 1 : BATTERY COMPARTMENT PANEL

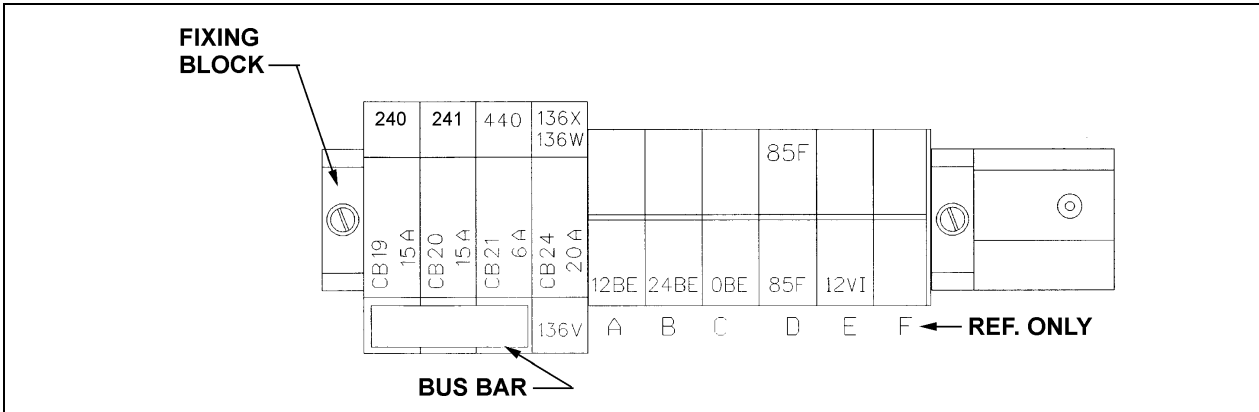

FIGURE 2 : BATTERY COMPARTMENT JUNCTION BOX BEFORE MODIFICATION

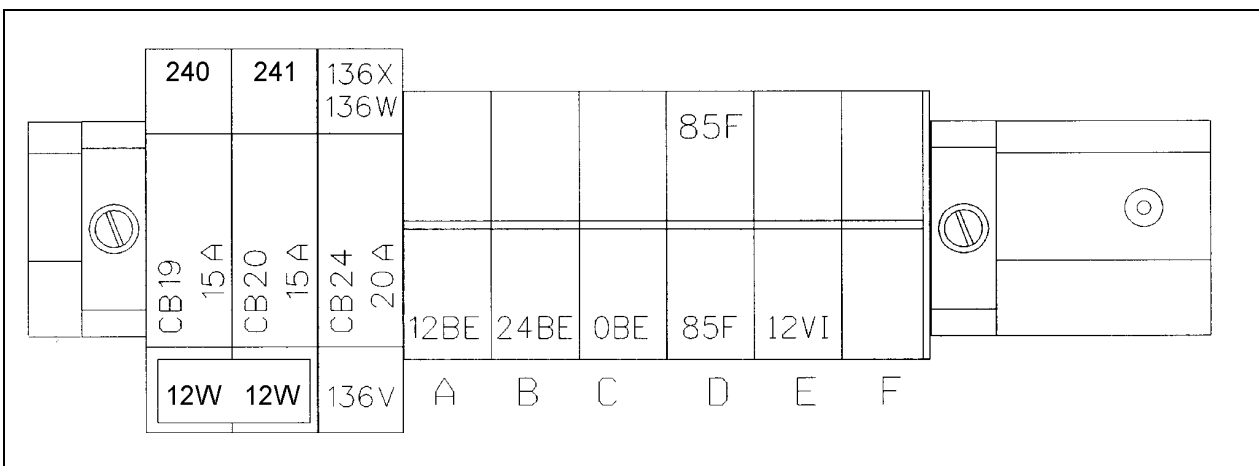

FIGURE 3 : BATTERY COMPARTMENT JUNCTION BOX AFTER MODIFICATION

3. Open rear electrical compartment, locate on the rear junction box lower panel the 12 volts circuit breaker fixing block. Unfasten fixing block and install CB 21 circuit breaker (Prévost #561792). Reinstall fixing block (refer to figure 4).
4. Using jumper cable assembly (Prévost #064870), secure 12I and 439 terminal lugs onto circuit breaker terminals and 12I lug onto B terminal respectively. Route cable assembly as shown in figure 4. Secure using cable ties (Prévost #504637).
5. Move to the rear junction box upper panel and connect jumper cable assembly 439 connectors with relay R8 and R11 87 connector as shown in figure 4. Secure using cable ties.

Note : For H3-41 and H3-45 coaches, refer to wiring diagram D060902, pages 2.1, 5.1 and 6.1 Rev. 9. For VIP-45, refer to wiring diagram D060912, pages 2.1, 5.1 and 6.1 Rev. 2.

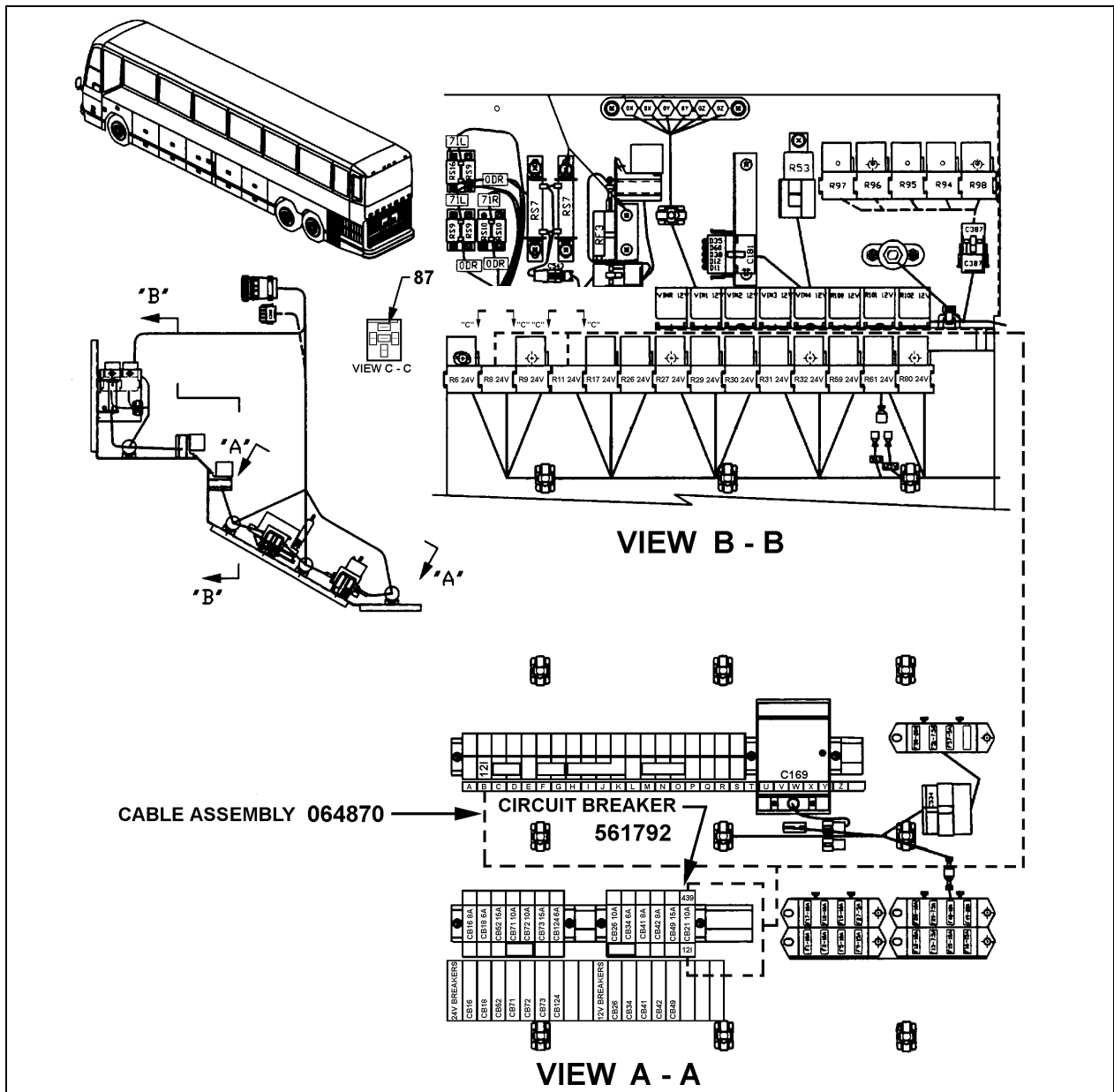

FIGURE 1 : REAR ELECTRICAL COMPARTMENT JUNCTION BOX

WARRANTY

This modification is covered by Prévost Car's normal warranty. We will reimburse you the parts and one half hour (0.50) of labor upon receipt of a completed A.F.A. form on which you must specify as per "Warranty Bulletin 98-30".

Parts disposition :

- Discard according to applicable environmental regulations (Municipal/State[Prov.]/ Federal)

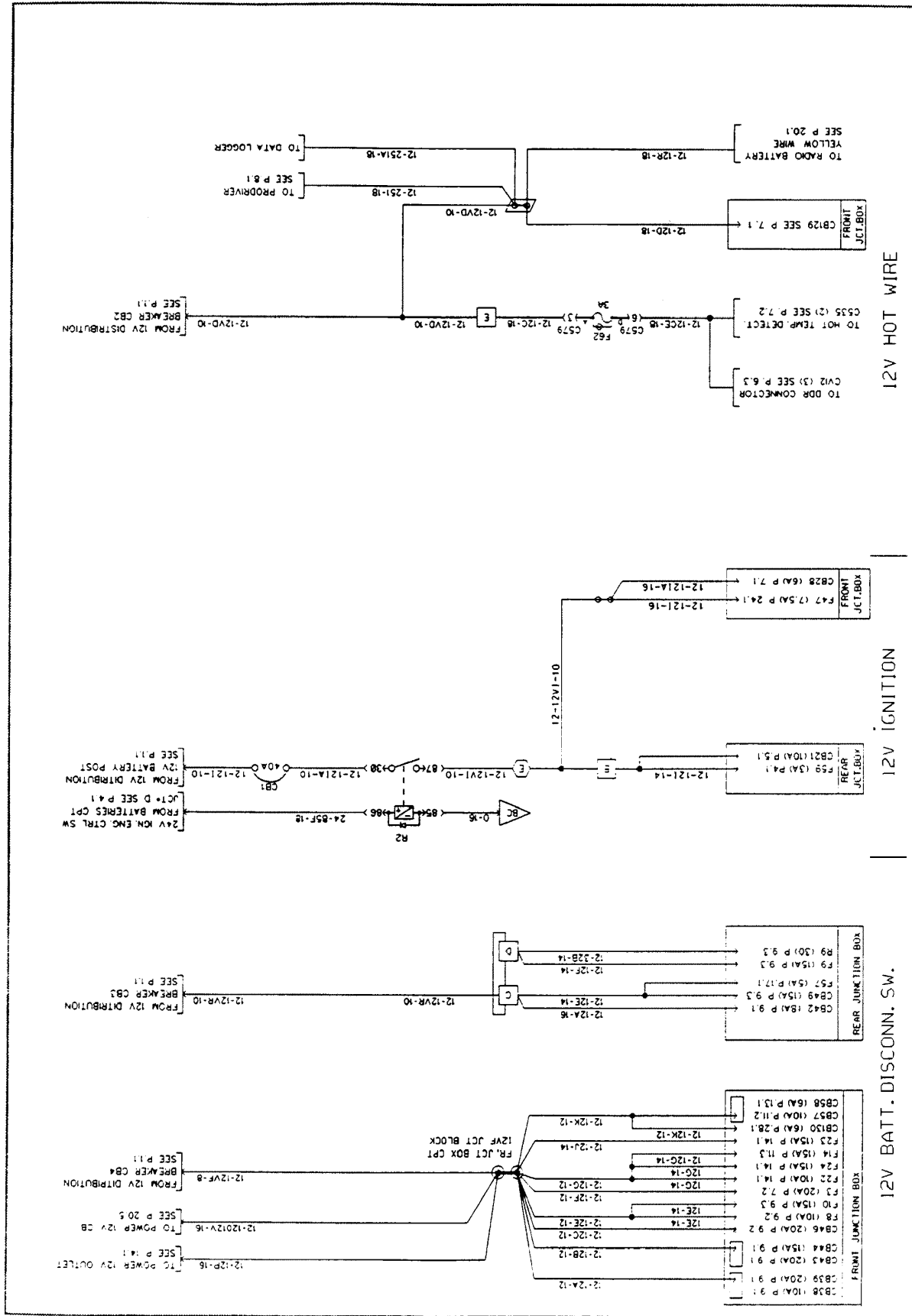

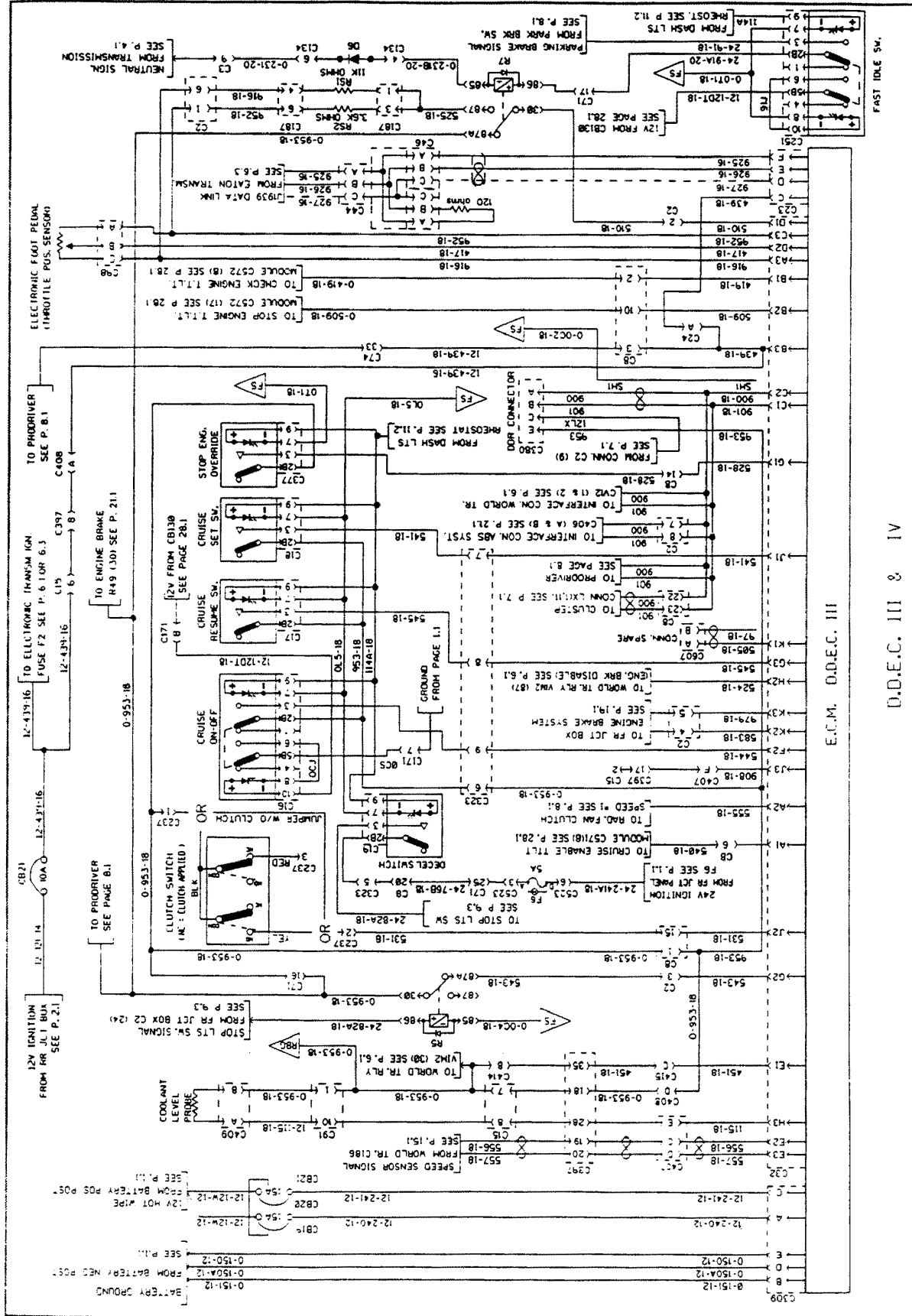

FAST IDLE SW.

E.C.M. O.D.E.C. III

O.D.E.C. III & IV

