

PREVOST





Instruction Sheet

IS-15905

CONDENSER LOWER REINFORCEMENT PLATE - NYCT

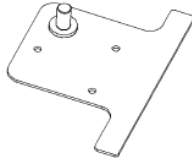
MATERIAL

Kit #454965 includes the following parts:

Part No.	Description		QTY
454959	Lower Reinforcement Plate		1
507260	Nylon Bushing		1
504379	Rivets 3/16 x 1/4"		3
504637	Cable tie		10
IS-15905	Instruction Sheet	-	1

Recommended Equipment:

Material	Description	Note
	Drill bit set (135° tip)	3/16" required (Sheet metal compatible with 135° tips)

 A black and green electric drill is shown with a green drill bit stopper attached to its bit. Several other green stoppers of different sizes are scattered around the base of the drill.	Drill bit stopper	to match the drill 3/16" bits used
 A black and silver cordless electric drill with a black handle and a silver body.	Electric Drill	
 A set of silver sockets and a silver socket wrench. The sockets are arranged in a row, and the wrench is positioned below them.	Socket wrench set	13mm (1/2") socket required
 A black and orange pop rivet gun with a long handle and a trigger mechanism.	Pop rivet gun	
 A pair of silver cutting pliers with blue handles and a circular cutting edge.	Cutting plier	Or suitable/equivalent tool
 A silver center punch with a textured handle and a sharp, pointed tip.	Center punch	Automatic
 A yellow scissor lift table with a black frame and four wheels.	Lift table	Wheeled

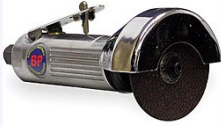
	Screwdriver	Phillips Head
	Rotary Cutter or Die Grinder	With small dia. cutting wheel

NOTE
Material can be obtained through regular channels.

PROCEDURE

 **DANGER**

Park vehicle safely, apply parking brake, stop engine and set battery master switch(es) to the OFF position prior to working on the vehicle.

1. Open the condenser door by pulling the latch located in the fuel filler compartment (Fig.1 & 2).



Fig.1

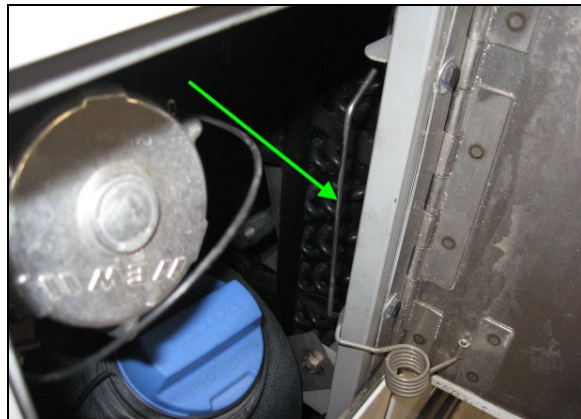

Fig.2

2. Disconnect the door limiter strap at the door end to allow complete opening of the door (Fig.3 & 4).



Fig.3

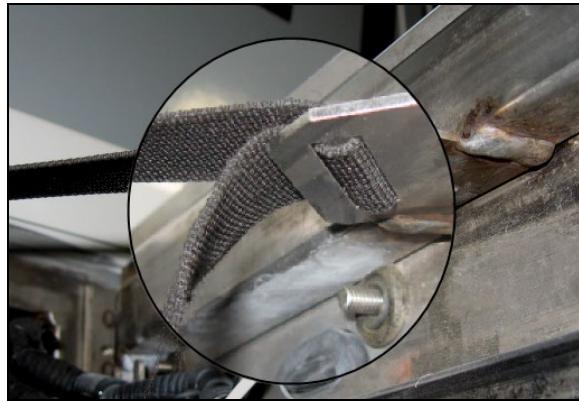

Fig.4

3. Pull the condenser latch and tilt the compressor 90deg out by pulling on the strap located on the side of the condenser (Fig.5 & 6).



CAUTION

Only the strap should be used to pull the condenser-fan assembly open. Damage to condenser could result if pulling by other means.

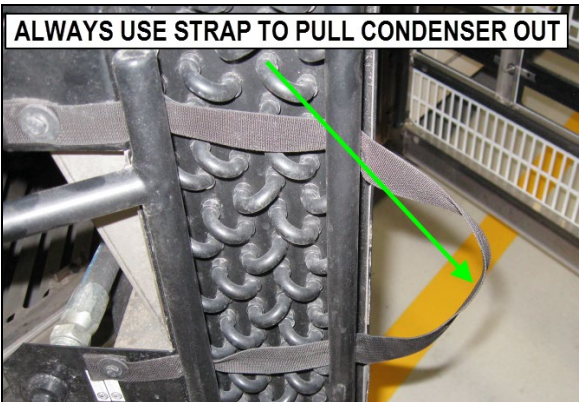

Fig.5

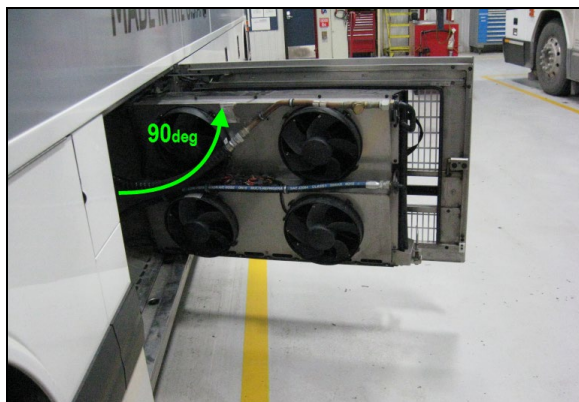

Fig.6

4. Put a hydraulic lift table under the condenser to support it. Lift slightly, just enough to remove weight on the lower support (Fig.7 & 8).



Fig.7



Fig.8

5. Cut the cable tie on the top pivot bracket and the adjacent wiring harness (Fig.9).
6. Remove the bracket from the vehicle by unscrewing the two (2) M8 hex bolts (13mm or 1/2" head) securing it to the frame (Fig.10).

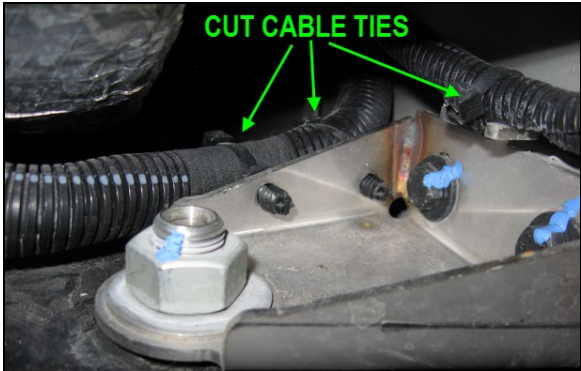

Fig.9

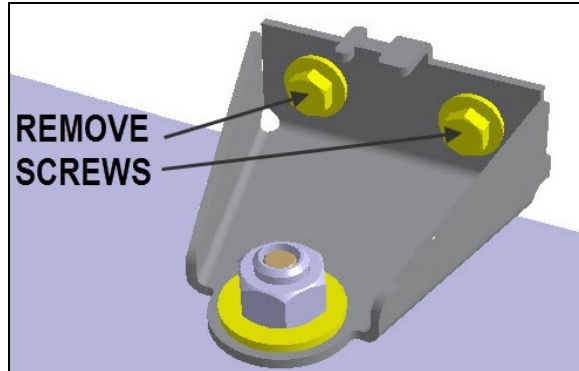

Fig.10

7. Remove two (2) of the P-Clamps that secure the lower condenser hose to the condenser body (Fig.11).

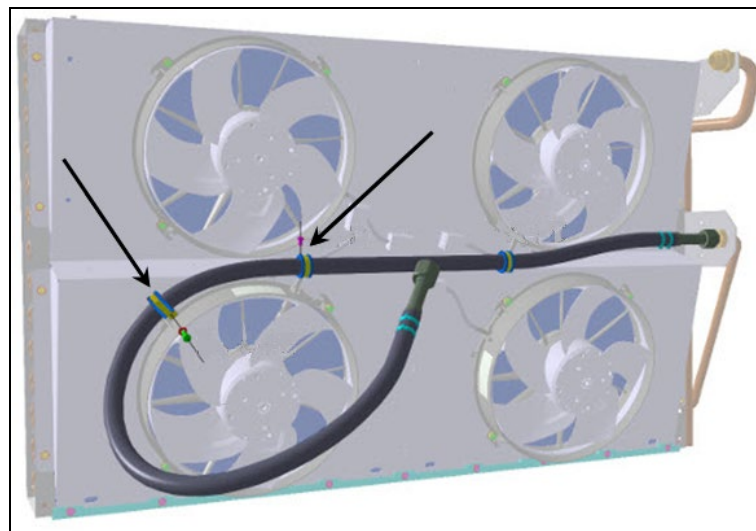

Fig.11

8. Cut the three (3) cable ties and disconnect the condenser wiring harness in the condenser compartment (two connectors Fig.12 & 13).

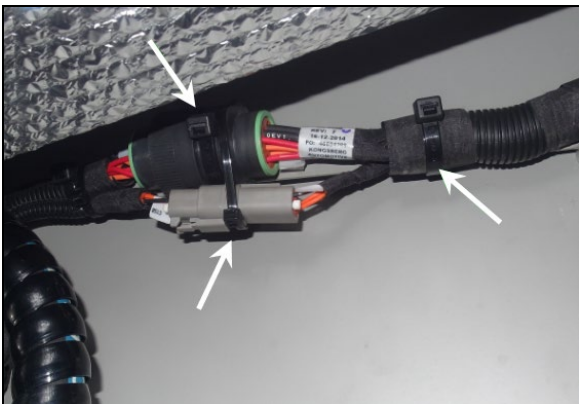

Fig.12

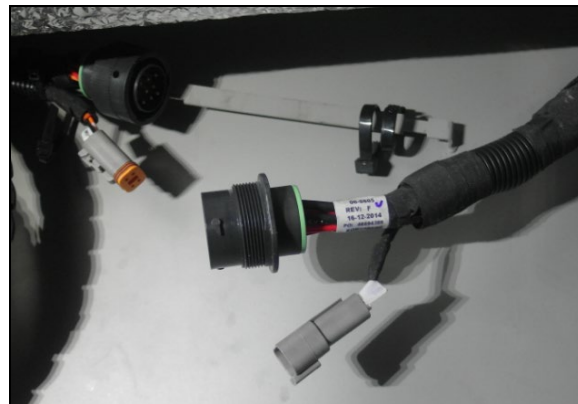

Fig.13

9. Cut the cable tie securing the harness to the upper door corner (Fig.14).

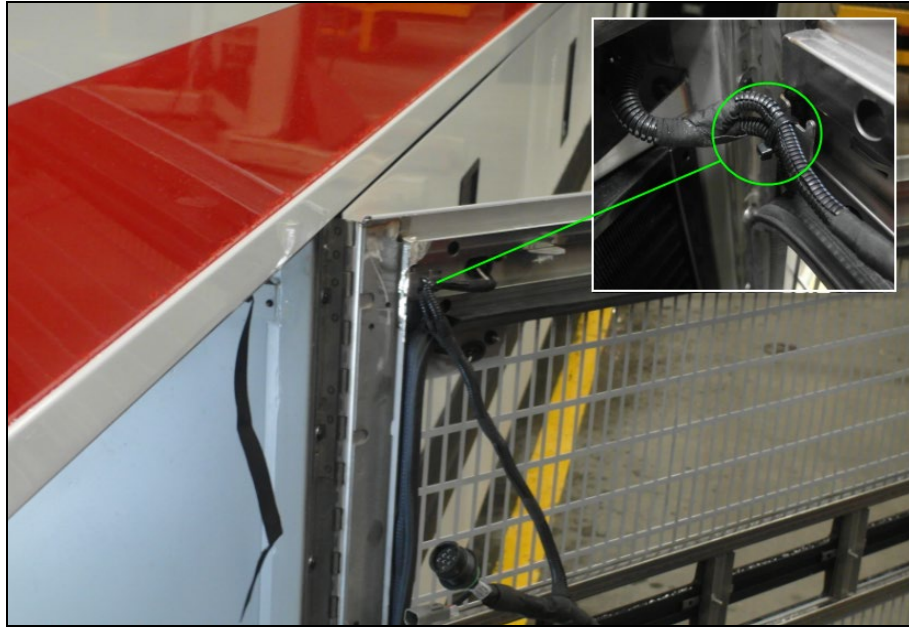

Fig.14

10. Remove the three (3) cable ties securing the harness to the condenser body (Fig.15).



Fig.15

- Using a Phillips screwdriver, remove the five (5) Phillips head screws that hold the condenser plastic slider exterior (door side) part to the condenser (Fig.16). Do not remove the nine (9) interior (fan side) screws yet.

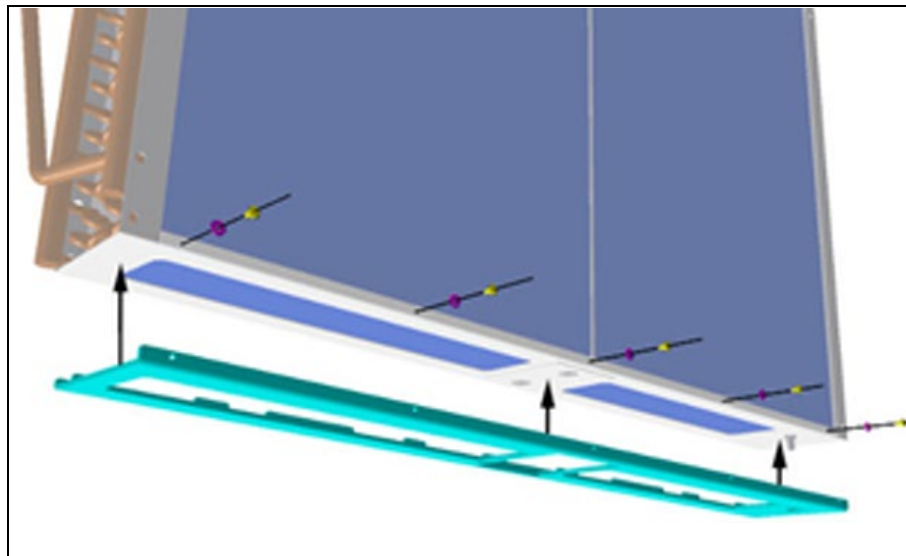

Fig.16

- With the help of a colleague, slightly pull the condenser toward the rear of the vehicle and flip it on its side to gain access to the bottom part of the condenser (Fig.17).

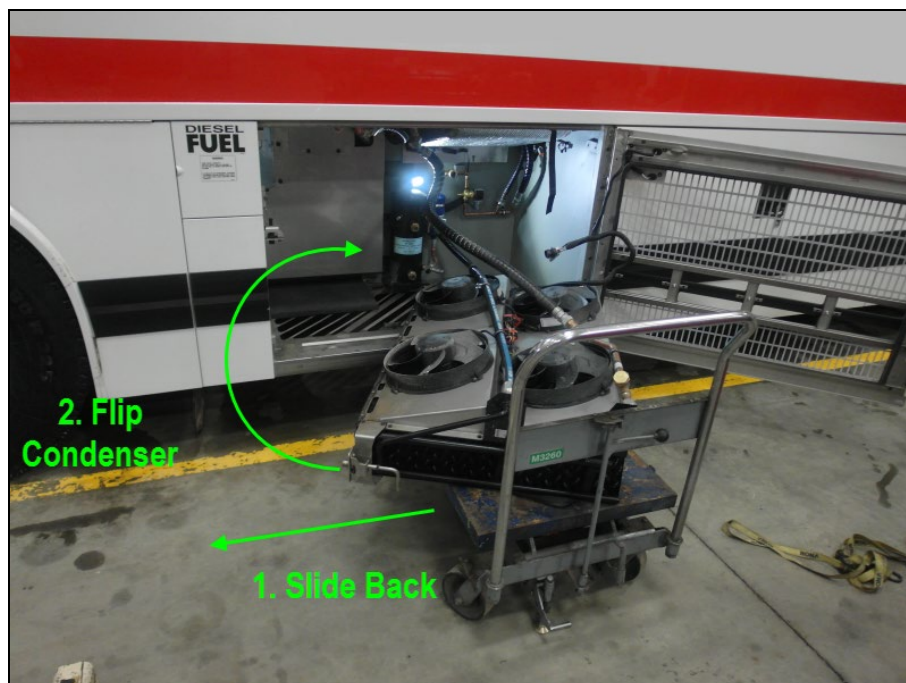

Fig.17



WARNING



Care must be taken not to damage the condenser by sliding it over the condenser stop welded at the bottom of the compartment.

13. With a Phillips head screwdriver, remove the nine (9) remaining screws (fan side) holding the plastic slider at the lower part of the condenser (Fig.18).



Fig.18

14. With the plastic slider on a bench, cut the left end (pivot pin side) following the picture below (Fig.19).

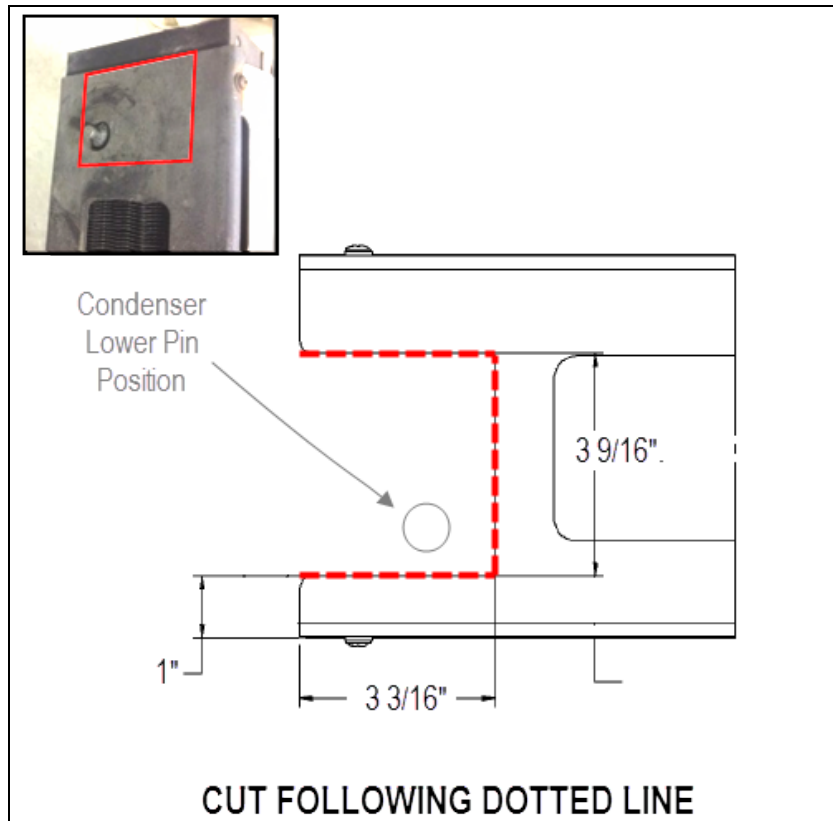

Fig.19

15. Put back the plastic slider in its place and reinstall the nine (9) fan side screws.
16. Install the edges of the lower reinforcement plate flush with the condenser body and mark the center of the plate holes using a center punch (Fig.20 & 21).

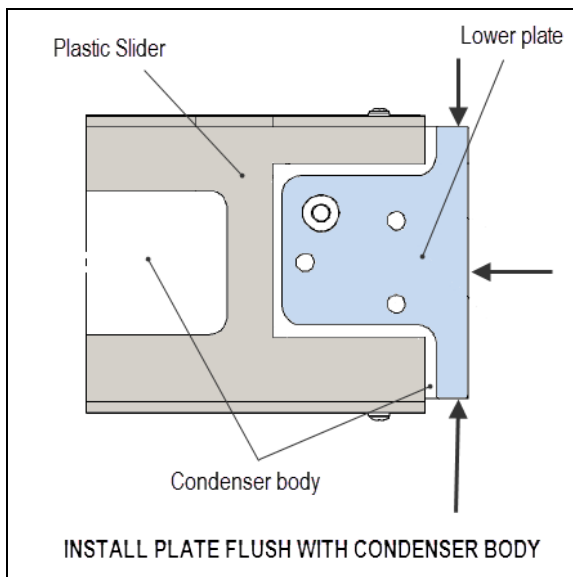

Fig.20

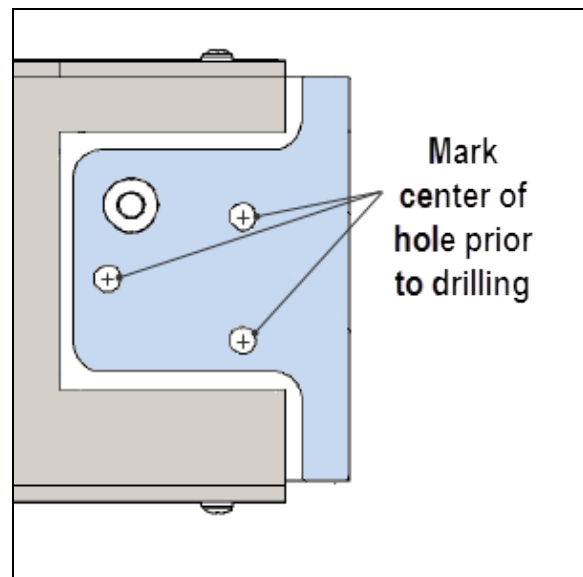

Fig.21

17. Using an electric drill, a 3/16" drill bit and an appropriate drill stop; drill the three (3) holes at the bottom of the condenser. Do not drill deeper than 1/4" (Fig.22 & 23).

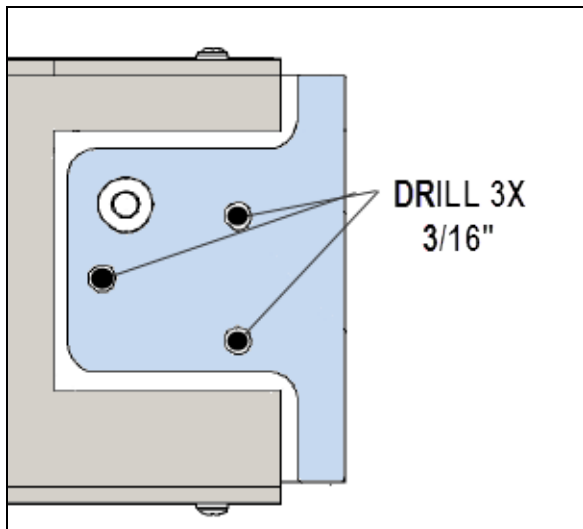

Fig.22

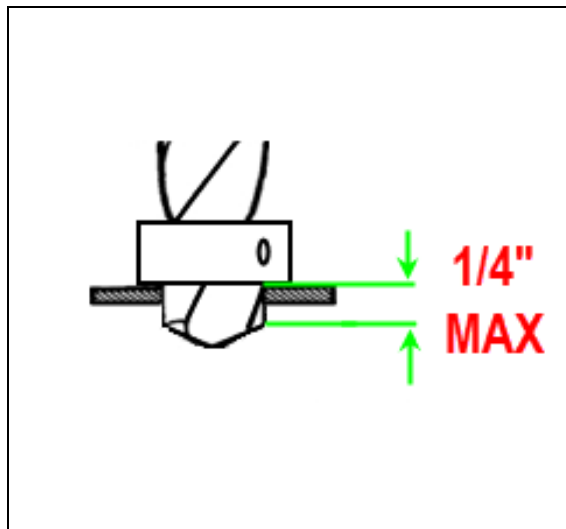

Fig.23

18. Once the three (3) holes are drilled, reposition the plate and secure it using the three (3) #504379 rivets included in the kit (Fig.24).

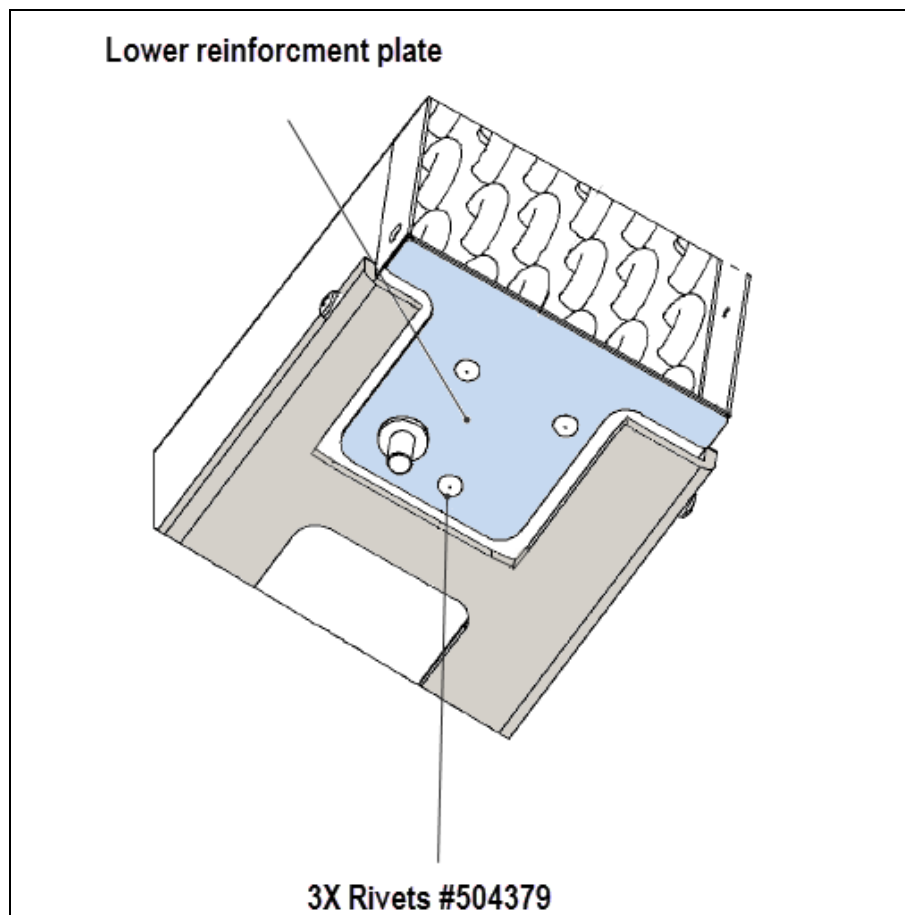

Fig.24

19. Prior to condenser reinstallation, install a new #507260 nylon bushing in the lower compartment pin hole (Fig 25 & 26).

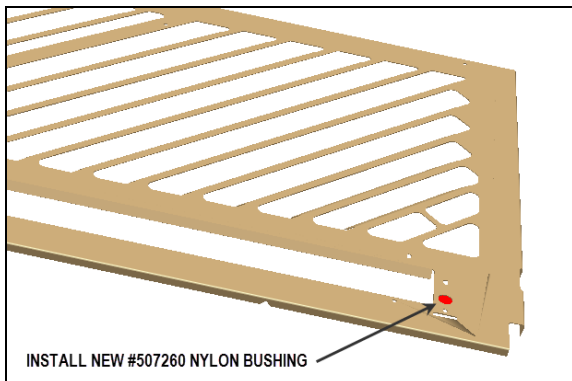

Fig.25

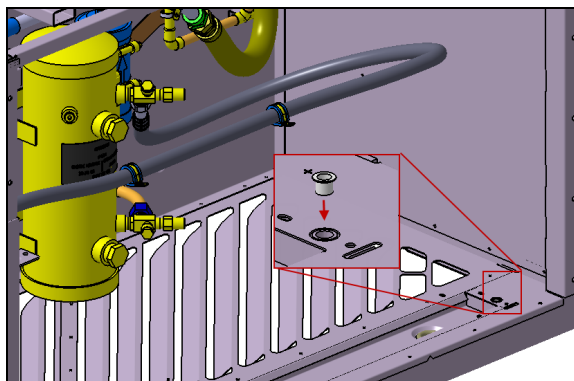

Fig.26

20. With the help of a colleague, put back the condenser in the straight-up position.
21. Screw back the remaining five (5) Phillips head screws that hold the front (door side) part of the slider.
22. Lift the condenser slightly with the lift table so the lower pin will clear the compartment floor.
23. Slowly bring the condenser into position over the pin recess in the compartment floor (Fig.27).
24. Lower the condenser making sure that the lower pin engages in the pin recess (Fig.28).

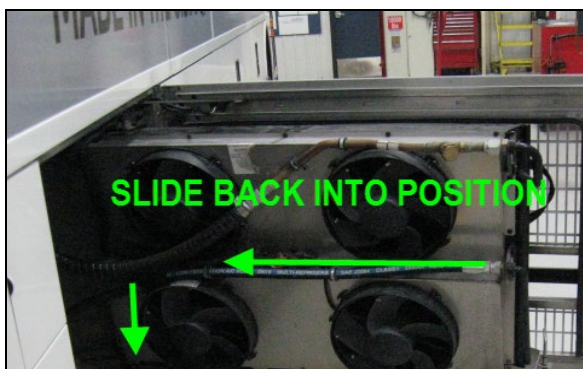

Fig.27



Fig.28

25. Reinstall the upper condenser pivot bracket and tighten the two (2) M8 hex bolts to 25 lbs.-ft. (Fig.29).
26. Follow the original routing for the wiring harness (over the bracket) and secure it with three (3) cable ties (Fig.30).

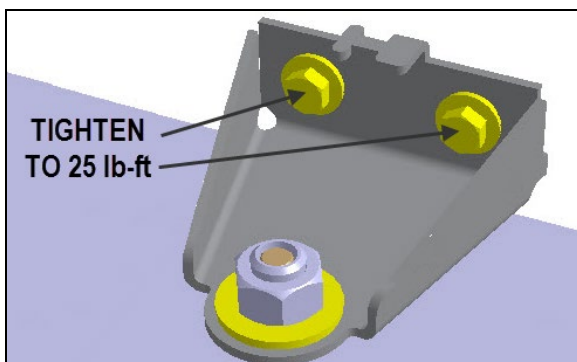

Fig.29

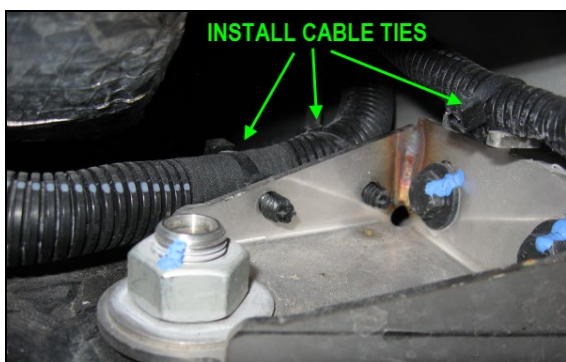

Fig.30

27. Install the three (3) cable ties that secure the harness to the condenser body (Fig.31).

28. Reinstall the harness at the upper door with a cable tie (Fig.32).



Fig.31

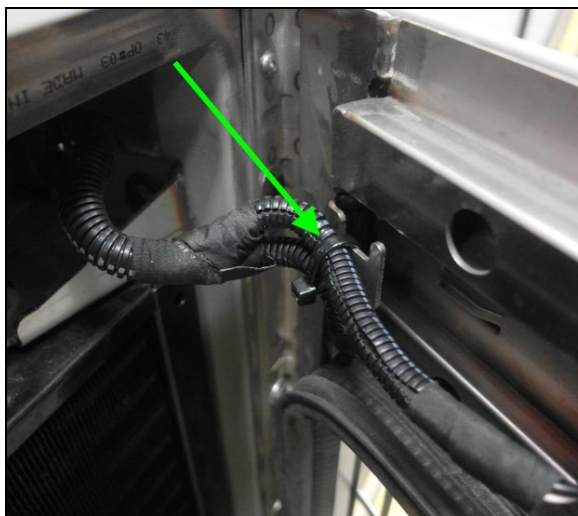

Fig.32

29. Reconnect the harness in the condenser compartment (Fig.33).

30. Install three (3) cable ties to secure the connectors like shown in the pictures below (Fig.34).

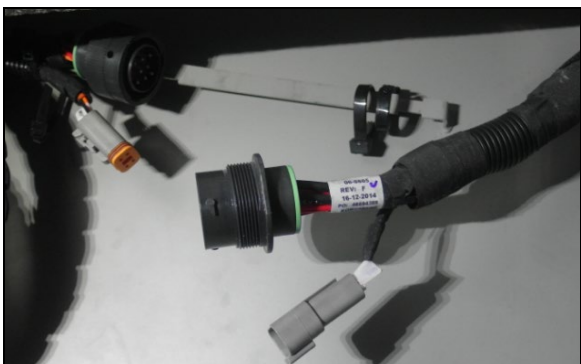

Fig.33

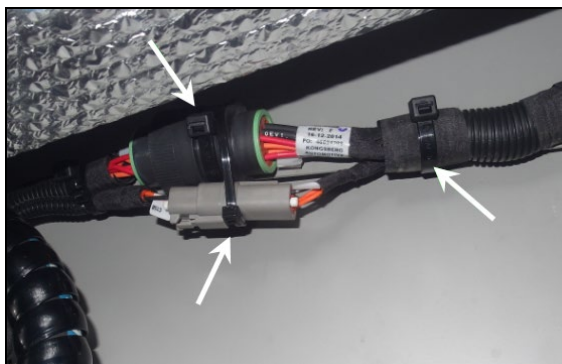

Fig.34

31. Attach the lower condenser hose to the condenser body by reinstalling the two (2) P-clamps previously removed (Fig.35).

32. Reinstall the condenser door limiter strap (Fig.36).

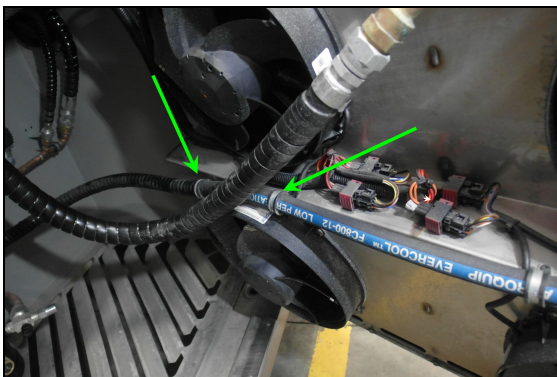

Fig.35

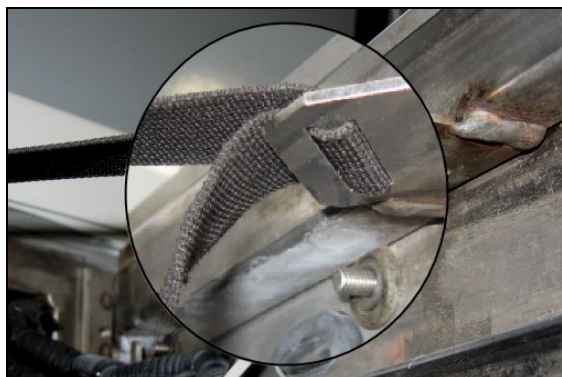

Fig.36

33. Check for proper operation by opening and closing the condenser door and sliding the condenser body in and out a few times.

PARTS / WASTE DISPOSAL

Discard waste according to applicable environmental regulations (Municipal/State[Prov.]/ Federal)