



**MAINTENANCE  
INFORMATION**

**MI15-56**

DATE :	NOVEMBER 2015	SECTION :	23 - Accessories
SUBJECT :	<b>MALFUNCTIONING OF R.H. SIDE ELECTRICAL SUNSHADE ON US07 VEHICLES</b>		

**IMPORTANT NOTICE**  
*This modification is recommended by PrevoSt to increase your vehicle's performance. Note that no reimbursement will be awarded for carrying out this modification.*

**APPLICATION**

Model	VIN	
Vehicles complying to EPA US07 regulation equipped with sunshade control buttons on steering wheel		

**DESCRIPTION**

On vehicles mentioned above, should the curbside electric sunshade fail to operate without encountering a drive mechanism issue, perform the following procedure.

**MATERIAL**

Part No	Description	Qty
-	WIRE, ELECTRICAL 14AWG BLACK	Approx. 3 feet
-	SHRINK TUBING	3 inches
563296	TERMINAL, FEMALE 14GA , YAZAKI #7116412102	1

**PROCEDURE**

<b>DANGER</b>
<p>Park vehicle safely, apply parking brake, stop engine. Prior to working on the vehicle, set the ignition switch to the OFF position and trip the main circuit breakers equipped with a trip button. On Commuter type vehicles, set the battery master switch (master cut-out) to the OFF position.</p>

**FIX: Add a 14AWG black wire (ground circuit) between multiplex module A55 (connector J2, cavity no.1) and the telltale module A12 (cavity no.5).**

1. Remove the dashboard cover.
2. Module A55, cavity no.1 is already used by the circuit 00B. Remove circuit 00B from the connector then cut and discard the terminal.

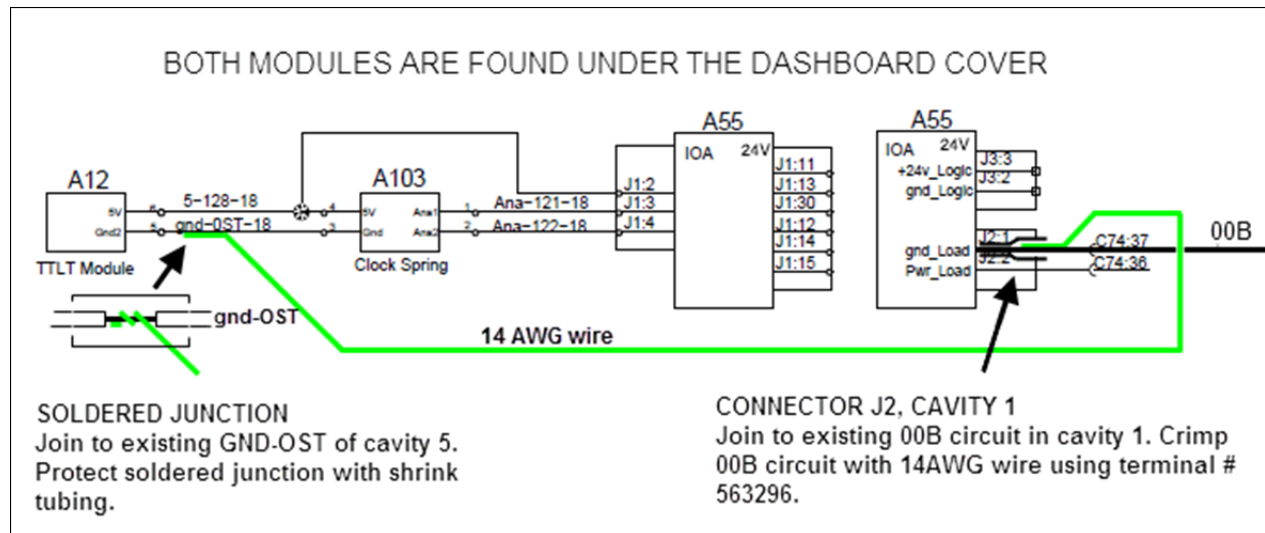

3. Join the 14AWG wire with circuit 00B. Crimp both circuits in a female terminal #563296 (**YAZAKI #7116412102, 6.3 System**), and then reinstall the new terminal in cavity no.1 of connector J2 (consult the Yazaki manual annexed).
4. Close to module A12, while taking care not to cut the wire, clear a part of circuit gnd-OST sheath and solder the other end of the 14AWG wire. To protect this junction, cover with shrink tubing to protect.
5. Secure the new wire to nearby harness using nylon ties.
6. Replace the dashboard cover can test the functioning of the sunshade.

## PARTS / WASTE DISPOSAL

Discard according to applicable environmental regulations (Municipal/State[Prov.]/ Federal)



Access all our Service Bulletins on <https://secureus5.volvo.com/technicalpublications/en/pub.asp>  
Or scan the QR-Code with your smart phone.

E-mail us at [technicalpublications\\_prev@volvo.com](mailto:technicalpublications_prev@volvo.com) and type "ADD" in the subject to receive our warranty bulletins by e-mail.

YPES-15-240

Handling Manual  
For  
YESC Connector  
2.8 System, 6.3 System and  
Hybrid System

<Note>

Please be informed that the contents in this handling manual may be revised without notice.

YAZAKI PARTS CO., LTD  
YAZAKI CORPORATION  
AUG.01.2001

# Table of Contents

1. Introduction .....	2
2. Description of part names and functions of terminals, housing and front holders .....	3
3. Parts storage and Transportation Precautions .....	7
4. Terminal Crimping Specification .....	9
5. Handling of Terminal crimped Wires .....	15
6. Terminal and Front Holder Setting Instructions and Precautions .....	16
7. Terminal and Front Holder Removal Instructions and Precautions .....	19
8. Male Connector Terminal Alignment inspection .....	26
9. Precautions During Wire Harness Installation in to the Vehicle .....	30
10. Precautions During Completed Vehicle Inspection .....	31
11. Precautions During Dealer's Service .....	31
12. Notice for Packing of wire harness .....	34
13. Connector Configurations and figures of Part Numbers .....	Attached sheet

## 1. INTRODUCTION

THIS HANDLING MANUAL IS PREPARED FOR WIRING HARNESS SUPPLIERS, VEHICLE MANUFACTURERS, ETC.

REGARDING THE HANDLING OF 1.5 SYSTEM CONNECTOR, PLEASE REFER TO THE HANDLING MANUAL FOR 1.5 SYSTEM CONNECTOR (YESC-15-239).

<NOTE>

THIS HANDLING MANUAL MAY BE SUBJECT TO REVISION WITHOUT ANY NOTICE TO THE CUSTOMERS.

## 2. DESCRIPTION OF PART NAMES AND FUNCTIONS OF TERMINALS, HOUSINGS AND FRONT HOLDERS

### 2-1 MALE TERMINAL 2.8 SYSTEM

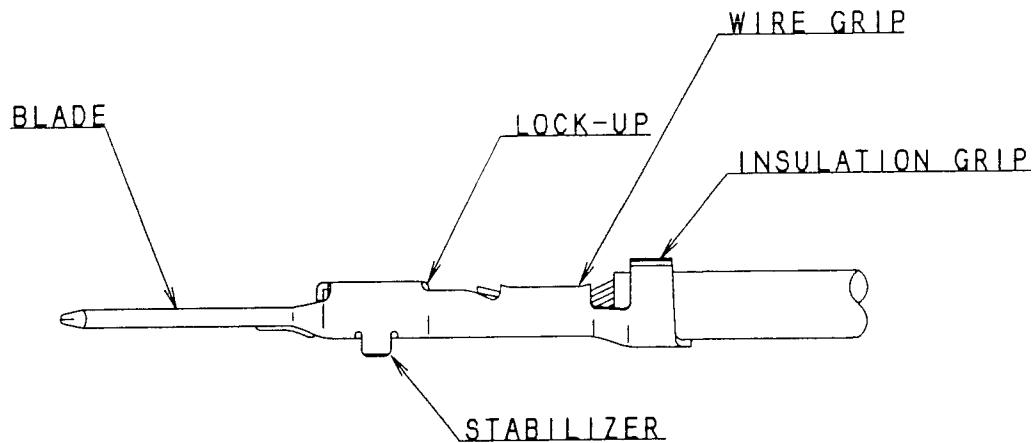

### 6.3 SYSTEM

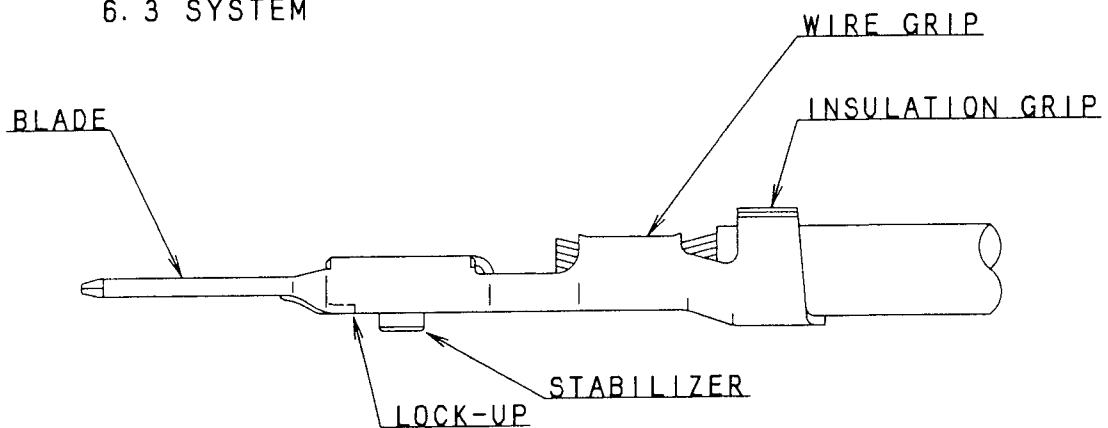

PART NAME	FUNCTION
BLADE	CONTACT WITH FEMALE TERMINAL
LOCK-UP	LOCK WITH HOUSING
STABILIZER	PREVENTION OF RATTLE AND WRONG SIDE INSERTION
WIRE GRIP	CONDUCTOR CRIMPING
INSULATION GRIP	INSULATION CRIMPING

2-2 FEMALE TERMINAL  
2.8 SYSTEM

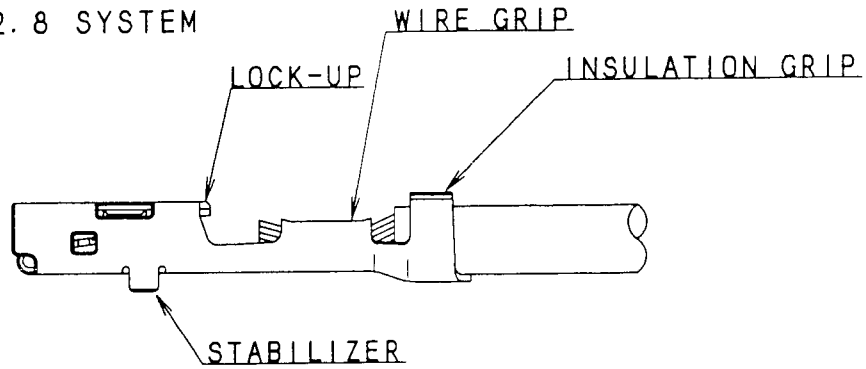

6.3 SYSTEM

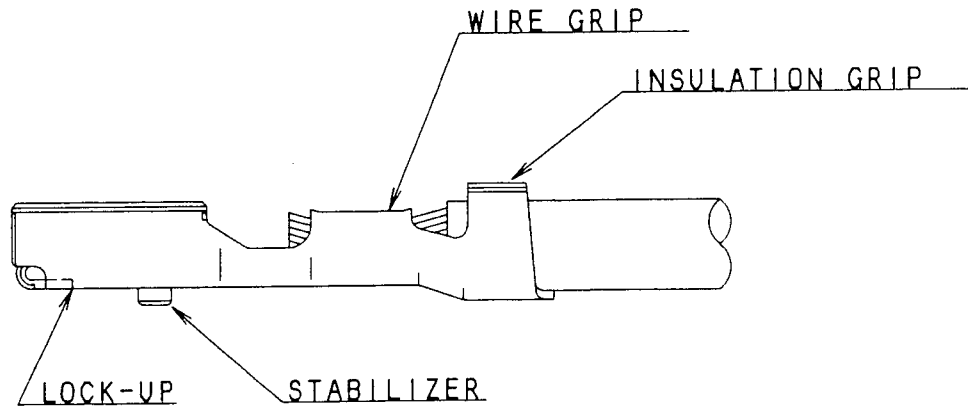

PART NAME	FUNCTION
LOCK-UP	LOCK WITH HOUSING
STABILIZER	PREVENTION OF RATTLE AND WRONG SIDE INSERTION
WIRE GRIP	CONDUCTOR CRIMPING
INSULATION GRIP	INSULATION CRIMPING

2-3 MALE HOUSING AND FRONT LOADED SPACER  
2.8 SYSTEM

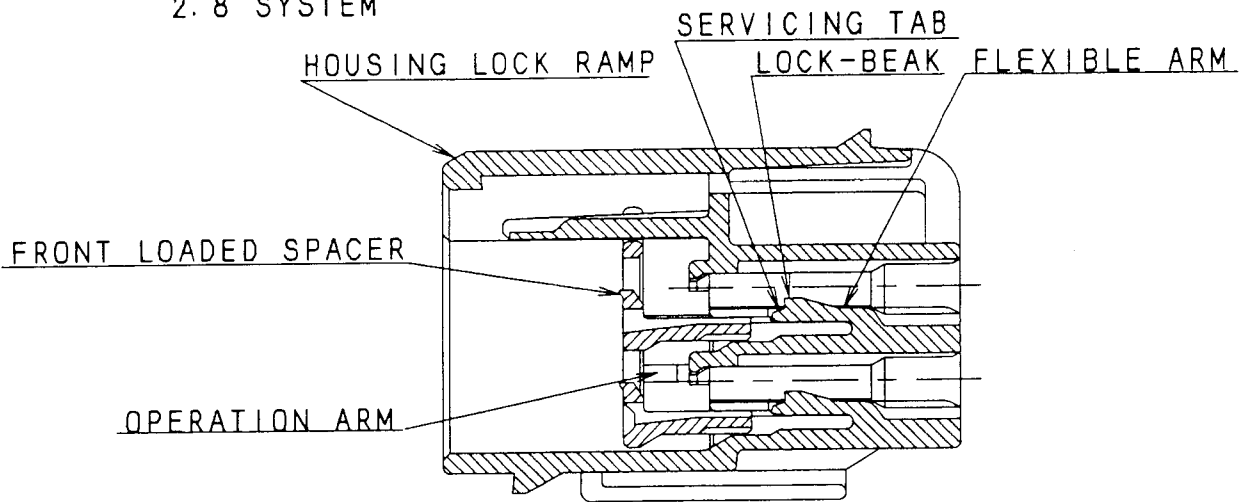

6.3 SYSTEM

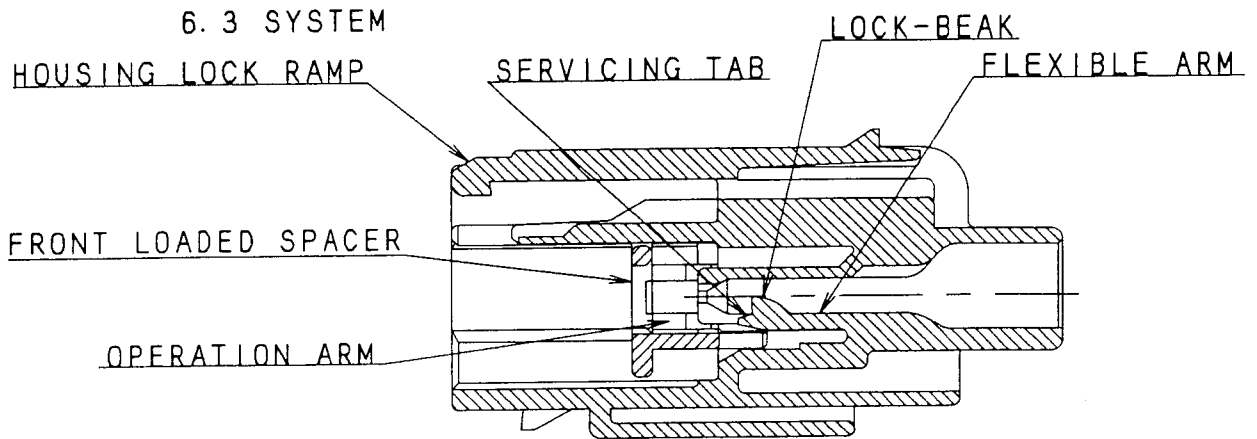

PART NAME	FUNCTION
HOUSING LANCE	TO LOCK WITH MALE TERMINAL
SERVICING TAB	TO RELEASE HOUSING LANCE LOCK
FLEXIBLE ARM	TO HOLD BEAK AND KEY
LOCK-BEAK	TO HOLD TERMINAL
HOUSING LOCK RAMP	TO LOCK WITH FEMALE HOUSING
FRONT LOADED SPACER	TERMINAL POSITION ASSURANCE
OPERATION ARM	SETTING AND RELEASING OF SECONDARY LOCKING



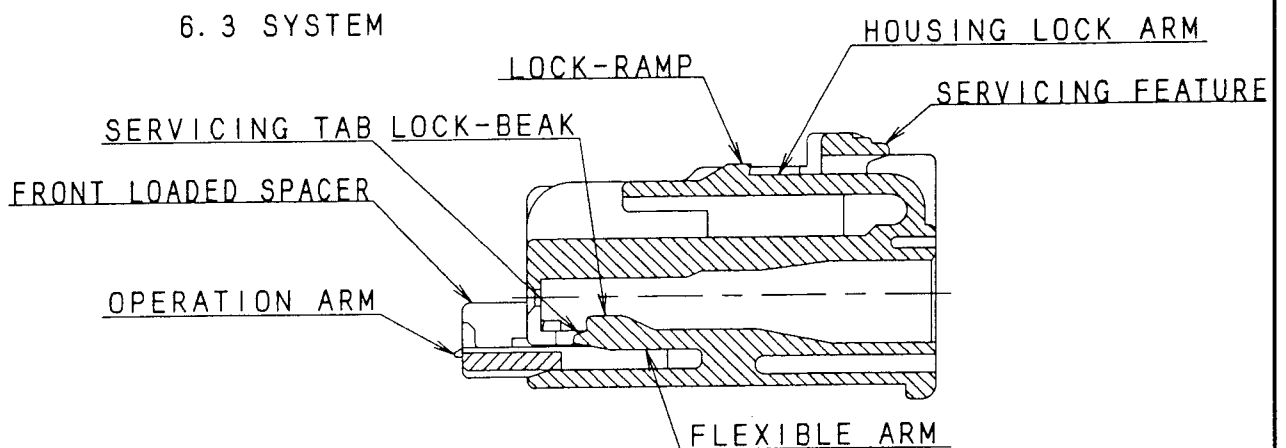
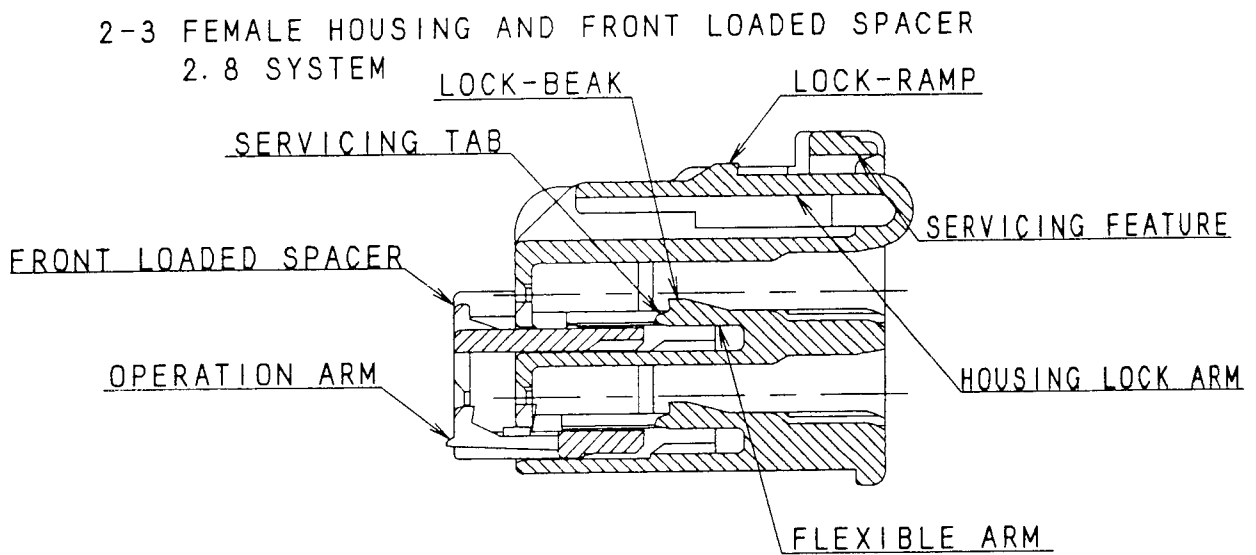

PART NAME	FUNCTION
HOUSING LANCE	TO LOCK WITH FEMALE TERMINAL
SERVICING TAB	TO RELEASE HOUSING LANCE LOCK
FLEXIBLE ARM	TO HOLD BEAK AND KEY
LOCK-BEAK	TO HOLD TERMINAL
LOCKING ARM	TO LOCK WITH MALE HOUSING
LOCK-RAMP	TO HOLD MALE HOUSING
SERVICING FEATURE	TO RELEASE HOUSING LOCK
FRONT LOADED SPACER	TERMINAL POSITION ASSURANCE
OPERATION ARM	SETTING AND RELEASING OF SECONDARY LOCKING

### 3. PARTS STORAGE AND TRANSPORTATION PRECAUTIONS

THE PARTS MUST BE FREE FROM DEFORMATION AND DAMAGE, ETC. DURING STORAGE AND TRANSPORTATION.

#### 3-1 TERMINAL

FOR STORAGE AND TRANSPORTATION, THE FOLLOWING METHODS MUST BE OBSERVED:

##### <TRANSPORTATION>

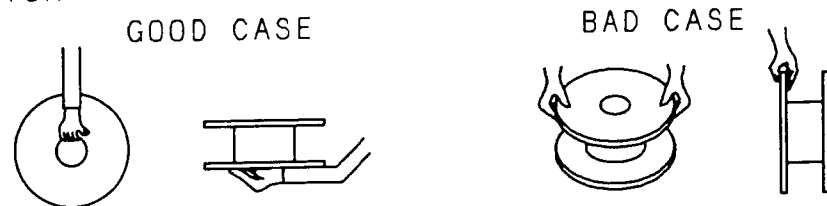

##### <STORAGE>

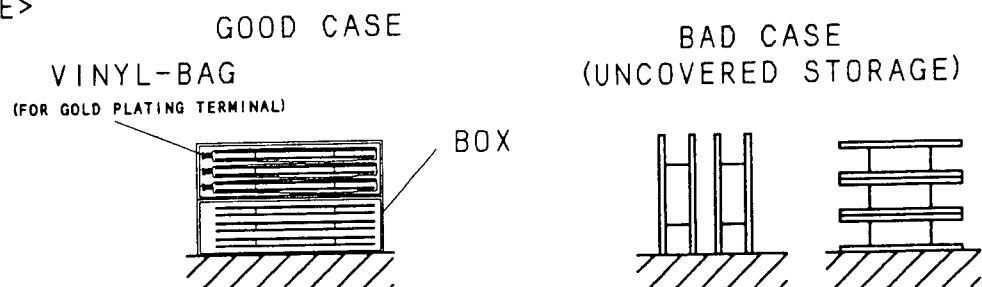

\*PILE UP TO MAX. 2 BOXES.

#### 3-2 HOUSING ETC.

STORE THEM IN THE BOX OR VINYL-BAG.

#### PRECAUTIONARY ITEMS

1. THE PARTS MUST BE STORED INDOORS WHERE IT IS NOT HUMID AND NO DIRECT EXPOSURE TO SUNLIGHT.
2. THE PARTS MUST NOT BE STORED UNCOVERED WITH BOX OR VINYL-BAG (THEY MUST BE PROTECTED ESPECIALLY FROM WATER, OIL AND DUST.)
3. AVOID ANY IMPACTS DURING TRANSPORTATION.
4. TERMINALS ARE FASTENED TO THE REEL WITH A WIRE AS SHOWN BELOW TO PREVENT TERMINAL FRAYING.

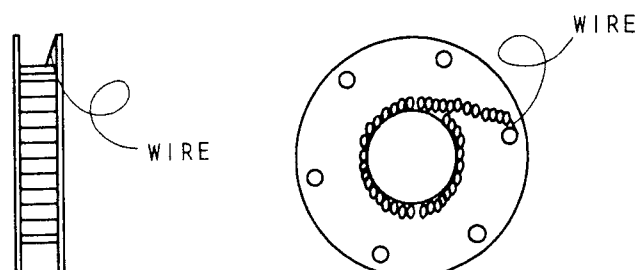

## 4. TERMINAL CRIMPING SPECIFICATION:

### 4-1 CRIMPING STANDARD:

THE FOLLOWING TABLE FOR THE CRIMPING STANDARD IS  
REFERENCE ONLY.

THEREFORE, CONTACT OUR SALES DEPARTMENT FOR THE  
 OFFICAL CRIMPING STANDARD.

TYPE	TERMINAL PART NO.	WIRE SIZE mm <sup>2</sup>	INSUL. STRIP LENGTH	WIRE BARREL		INSULATION BARREL	
				C/H	C/W	C/H	C/W
1.5 SYSTEM MALE	7114-4100-02	0.35	5.0	1.00 ~ 1.10	1.70 ~ 1.80	1.95 ~ 2.15	2.20 ~ 2.40
		0.5	5.0	1.05 ~ 1.15	1.70 ~ 1.80	2.10 ~ 2.30	2.20 ~ 2.40
	7114-4101-02	0.75	5.0	1.15 ~ 1.25	2.20 ~ 2.30	2.35 ~ 2.55	2.55 ~ 2.75
		1.0	5.0	1.20 ~ 1.30	2.20 ~ 2.30	2.55 ~ 2.75	2.55 ~ 2.75
	7114-4104-02	1.5	5.0	1.00 ~ 1.10	1.70 ~ 1.80	1.95 ~ 2.15	2.20 ~ 2.40
		0.35	5.0	0.90 ~ 1.00	1.70 ~ 1.80	1.80 ~ 2.00	2.20 ~ 2.40
1.5 SYSTEM FEMALE	7116-4100-02	0.5	5.0	0.95 ~ 1.05	1.70 ~ 1.80	1.95 ~ 2.15	2.20 ~ 2.40
		0.75	5.0	1.05 ~ 1.15	2.05 ~ 2.15	2.20 ~ 2.40	2.55 ~ 2.75
	7116-4101-02	1.0	5.0	1.15 ~ 1.25	2.05 ~ 2.15	2.40 ~ 2.60	2.55 ~ 2.75
		1.5	5.0	1.00 ~ 1.10	1.70 ~ 1.80	1.95 ~ 2.15	2.20 ~ 2.40
	7116-4104-02	0.35	5.0	0.95 ~ 1.05	1.85 ~ 2.05	1.80 ~ 2.00	2.35 ~ 2.55
		0.5	5.0	1.05 ~ 1.15	1.85 ~ 2.05	2.05 ~ 2.25	2.35 ~ 2.55
2.8 SYSTEM MALE	7114-4110-02	0.75	5.0	1.15 ~ 1.25	2.30 ~ 2.50	2.25 ~ 2.45	3.15 ~ 3.35
		1.0	5.0	1.25 ~ 1.35	2.30 ~ 2.50	2.40 ~ 2.60	3.15 ~ 3.35
	7114-4111-02	1.5	5.0	1.45 ~ 1.55	2.70 ~ 2.90	2.70 ~ 2.90	3.70 ~ 3.90
		2.5	5.0	1.65 ~ 1.75	2.70 ~ 2.90	3.10 ~ 3.30	3.70 ~ 3.90
	7114-4112-02	0.35	5.0	0.95 ~ 1.05	1.85 ~ 2.05	1.80 ~ 2.00	2.35 ~ 2.55
		0.5	5.0	1.05 ~ 1.15	1.85 ~ 2.05	2.05 ~ 2.25	2.35 ~ 2.55
2.8 SYSTEM FEMALE	7116-4110-02	0.75	5.0	1.15 ~ 1.25	2.30 ~ 2.50	2.25 ~ 2.45	3.15 ~ 3.35
		1.0	5.0	1.25 ~ 1.35	2.30 ~ 2.50	2.40 ~ 2.60	3.15 ~ 3.35
	7116-4116-02	1.5	5.0	1.45 ~ 1.55	2.70 ~ 2.90	2.70 ~ 2.90	3.70 ~ 3.90
		2.5	5.0	1.65 ~ 1.75	2.70 ~ 2.90	3.10 ~ 3.30	3.70 ~ 3.90
	7116-4112-02	0.35	5.0	0.95 ~ 1.05	1.85 ~ 2.05	1.80 ~ 2.00	2.35 ~ 2.55
		0.5	5.0	1.05 ~ 1.15	1.85 ~ 2.05	2.05 ~ 2.25	2.35 ~ 2.55
6.3 SYSTEM MALE	7114-4120-02	0.5	5.0	1.25 ~ 1.35	2.50 ~ 2.70	2.30 ~ 2.50	3.00 ~ 3.20
		0.75	5.0	1.30 ~ 1.40	2.50 ~ 2.70	2.45 ~ 2.65	3.00 ~ 3.20
	7114-4121-02	1.0	5.0	1.35 ~ 1.45	2.50 ~ 2.70	2.70 ~ 2.90	3.00 ~ 3.20
		1.5	5.0	1.60 ~ 1.70	2.95 ~ 3.15	3.00 ~ 3.20	3.75 ~ 3.95
	7114-4122-02	2.5	5.0	1.85 ~ 1.95	2.95 ~ 3.15	3.60 ~ 3.80	3.75 ~ 3.95
		4.0	5.5	2.10 ~ 2.20	3.55 ~ 3.75	4.05 ~ 4.15	4.45 ~ 4.65
6.3 SYSTEM FFEMALE	7116-4120-02	0.5	5.0	1.20 ~ 1.30	2.50 ~ 2.70	2.30 ~ 2.50	3.00 ~ 3.20
		0.75	5.0	1.25 ~ 1.35	2.50 ~ 2.70	2.45 ~ 2.65	3.00 ~ 3.20
	7116-4121-02	1.0	5.0	1.35 ~ 1.45	2.50 ~ 2.70	2.70 ~ 2.90	3.00 ~ 3.20
		1.5	5.0	1.60 ~ 1.70	2.95 ~ 3.15	3.00 ~ 3.20	3.75 ~ 3.95
	7116-4122-02	2.5	5.0	1.80 ~ 1.90	2.95 ~ 3.15	3.60 ~ 3.80	3.75 ~ 3.95
		4.0	5.5	2.10 ~ 2.20	3.55 ~ 3.75	4.05 ~ 4.15	4.45 ~ 4.65

<NOTE>



THE TOLERANCE FOR INSULATION STRIP LENGTH IS +0.5mm.

4-2 CRIMPING CHECK POINTS AND JUDGEMENT:

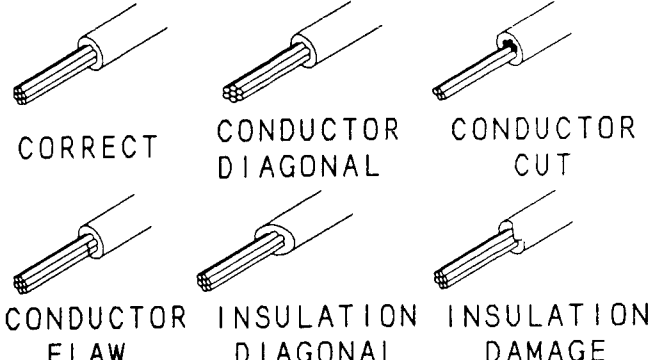
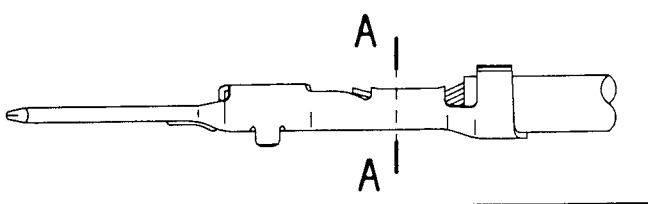
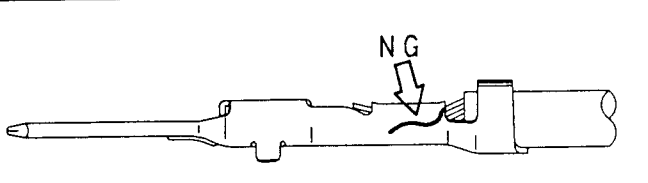
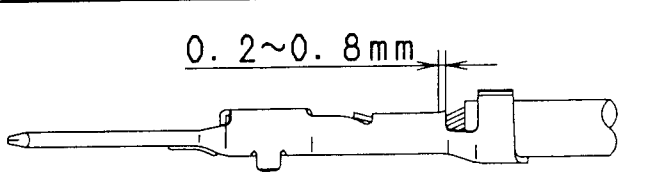
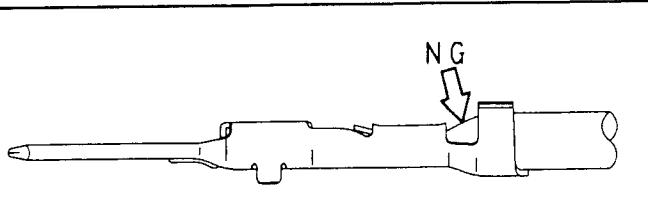
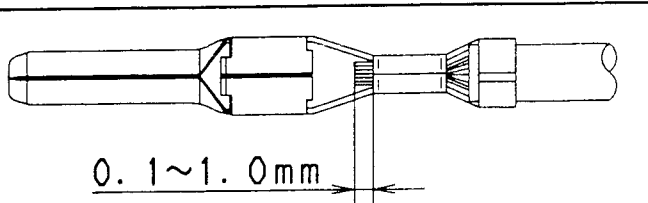
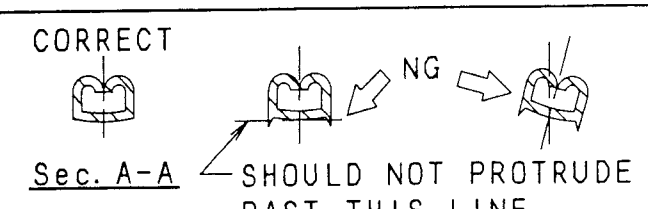
WHEN TERMINALS ARE CRIMPED, CARE MUST BE TAKEN ON THE FOLLOWING ITEMS:

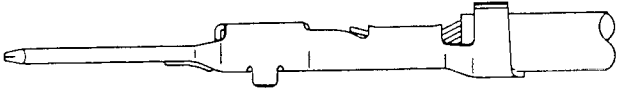
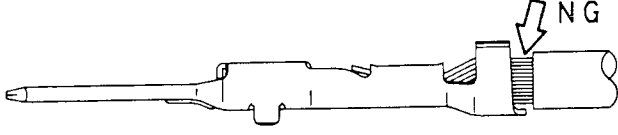
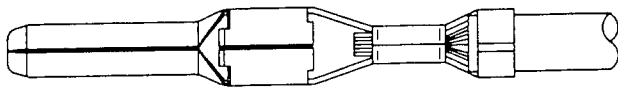
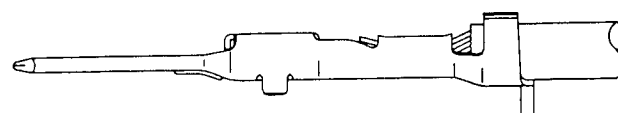
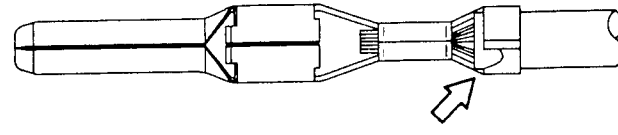
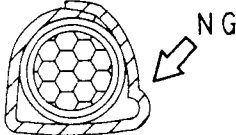
ITEM	CHECK POINT	JUDGEMENT
INSULATION STRIPPING	<ul style="list-style-type: none"> <li>· CONDUCTOR DIAGONAL CUTTING</li> <li>· CONDUCTOR CUT</li> <li>· ANY FLAW ON CONDUCTORS</li> <li>· INSULATION DIAGONAL CUT</li> <li>· ANY DAMAGE ON INSULATION</li> </ul>	 <p>CORRECT      CONDUCTOR DIAGONAL      CONDUCTOR CUT</p> <p>CONDUCTOR FLAW      INSULATION DIAGONAL      INSULATION DAMAGE</p>
CRIMPING OF WIRE GRIP MALE/FEMALE	CORRECT CRIMPING CONDITION	
	ANY CONDUCTOR FLAW	
	BELL-MOUTH	
	INSULATION CRIMPED BY WIRE BARREL	
	TOP LENGTH OF CONDUCTOR	
	BURR AND/OR TWIST	 <p>CORRECT</p> <p>Sec. A-A      NG      SHOULD NOT PROTRUDE PAST THIS LINE.</p>

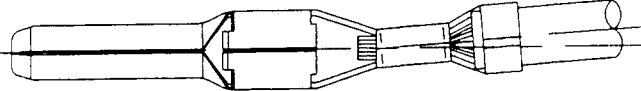
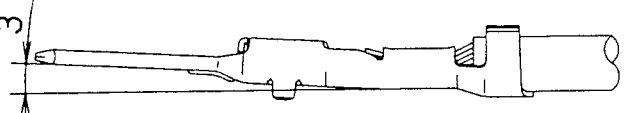
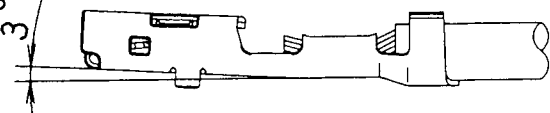
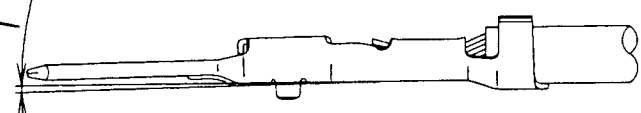
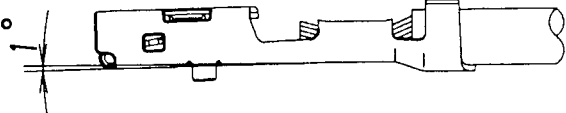
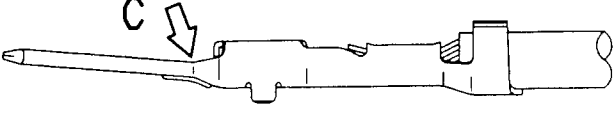
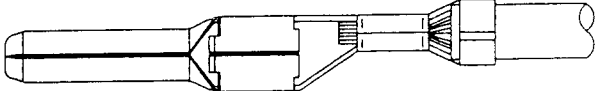
ITEM	CHECK POINT	JUDGEMENT
CRIMPING OF INSUL. GRIP  MALE/FEMALE	CORRECT CRIMPING CONDITION	THE END OF INSULATION MUST BE SEEN BETWEEN WIRE AND INSULATION GRIP.  
	INSULATION FALLS SHORT OF INSULATION GRIP	
	WRAP CRIMPING	THE INSULATION GRIP MUST BE WRAPPED.  
	CUT OFF LENGTH	 $0 \sim 0.3 \text{ mm}$
	DAMAGED INSULATION	INSULATION CRIMP PINCHES AND/OR VISIBLY DEFORMS THE WIRE INSULATION.  
	NO CREASE OF GRIP	

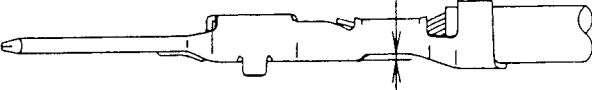
ITEM	CHECK POINT	JUDGEMENT
DEFORMATION BY CRIMPING	TWIST MALE/FEMALE	<p>TWISTED TERMINALS SHOULD BE REJECTED DURING VISUAL CHECKING.</p> 
	BENT UP	<p>THE DEGREE OF BENDING MUST BE 3° OR LESS.</p>  
	BENT DOWN	<p>THE DEGREE OF BENDING MUST BE 1° OR LESS.</p>  
	BLADE DEFORMATION	<p>DEFORMATION AT POINT C IS NOT ACCEPTABLE.</p> 
	BOX MISALIGNMENT MALE/FEMALE	
	BOX DEFORMATION	  NG
	CRIMP DISCREPANCY MALE/FEMALE	 NG

4-3 MEASUREMENT OF CRIMP HEIGHT AND CRIMP WIDTH:

PLEASE MEASURE THE CRIMP HEIGHT AND CRIMP WIDTH USING THE SPECIFIED EQUIPMENT.

FOR THE SPECIFIED EQUIPMENT, PLEASE REFER TO SECTION 4-4.

CRIMP HEIGHT

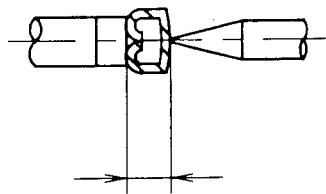

CRIMP WIDTH

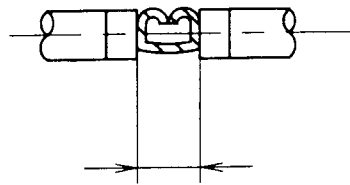

4-4 MEASURING EQUIPMENT:

THE MEASURING EQUIPMENT IS A MICROMETER WHICH SATISFIES THE SPECIFICATIONS SHOWN BELOW:

THIS MEASURING EQUIPMENT SHALL BE EQUIPPED WITH A STAND.

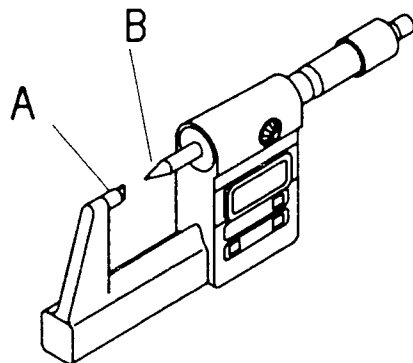

DETAIL OF A

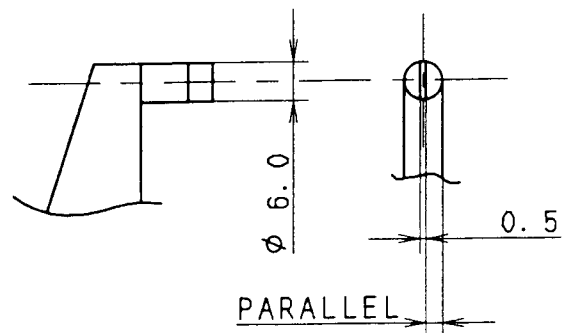

DETAIL OF B

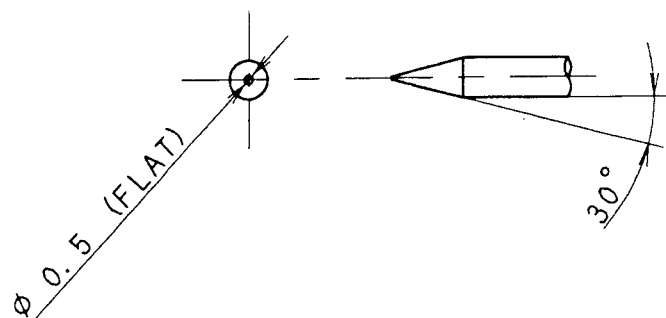

4-5 TERMINAL INSPECTION GAUGE (REFERENCE SPECIFICATIONS)

THE PURPOSE OF THIS GAUGE IS TO ASSURE THE CRIMPED TERMINAL IS WITHIN THE SPECIFIED BEND-UP/BEND-DOWN REQUIREMENTS/TOLERANCES.

<FOR 2.8 SYSTEM MALE>

APPLICABLE WIRE: WSK-M1L124-A (FORD), STD7613, 111 (VOLVO)

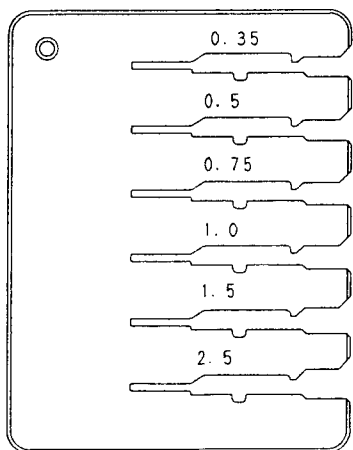
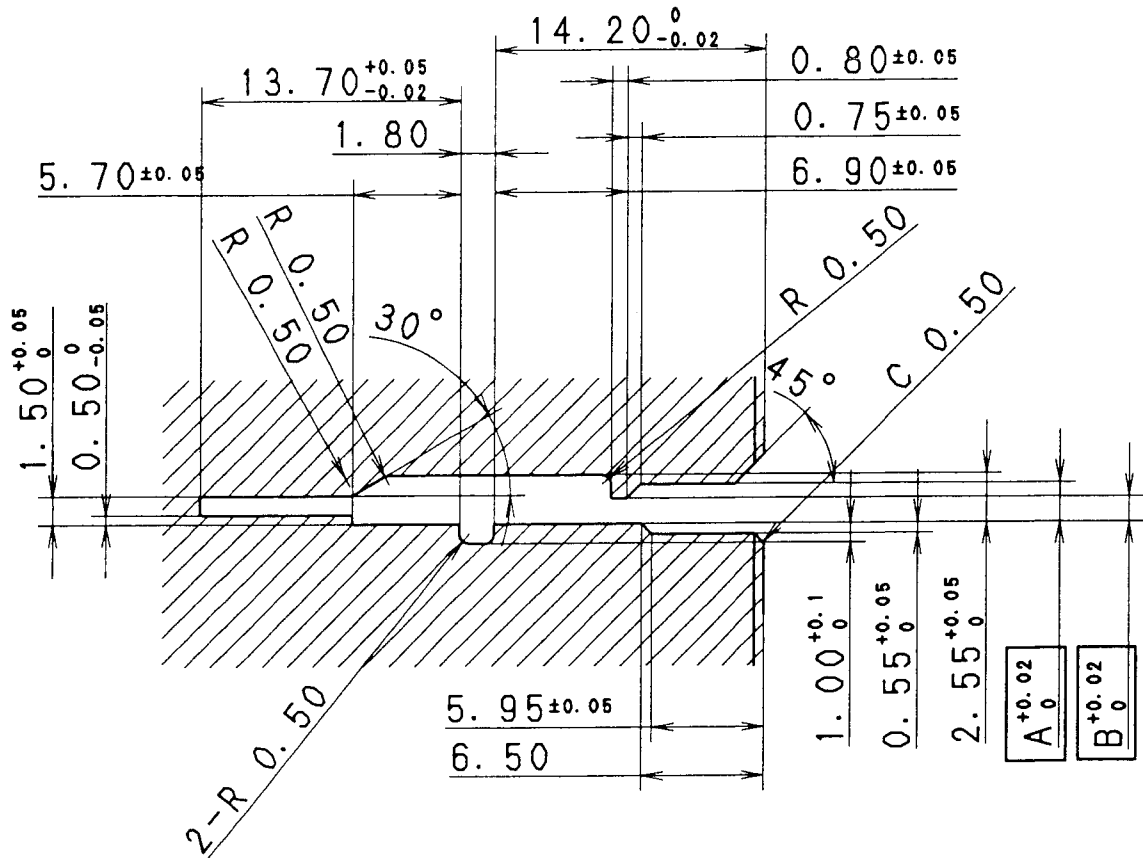

CRIMP GAUGE VARIABLE

WIRE SIZE	A	B
0.35	2.06	1.31
0.5	2.16	1.34
0.75	2.36	1.50
1.0	2.51	1.54
1.5	2.81	1.74
2.5	3.30	1.94



## METHOD FOR GAUGE USAGE

WHEN THE CRIMPED TERMINAL IS PARALLEL TO THE GAUGE SURFACE, IT MAY BE INSERTED THROUGH THE OPENING.

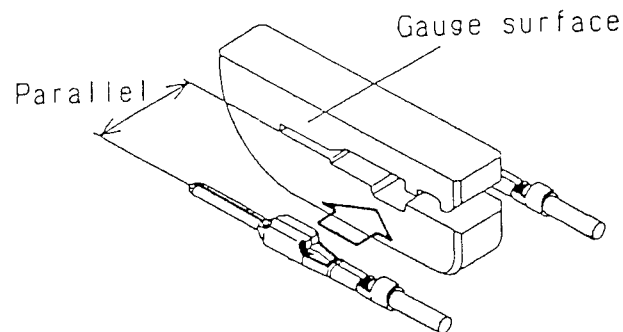

## EVALUATION CRITERIA

ACCEPTABLE : CRIMPED TERMINATION CAN SMOOTHLY PASS THROUGH GAUGE.

UNACCEPTABLE : CRIMPED TERMINATION IS OBSTRUCTED  
WHEN GAUGE USAGE IS ATTEMPTED.

## INSPECTION FREQUENCY

CONFORMANCE TO GAUGE INSPECTION IS RECOMMENDED  
AT THE BEGINNING AND END EACH PRODUCTION LOT.

## 5. HANDLING OF TERMINAL CRIMPED WIRES :

CARE MUST BE TAKEN ON THE FOLLOWING POINTS WHEN HANDLING TERMINAL CRIMPED WIRES.

1. THE TERMINAL CRIMPED WIRES SHALL BE PREPARED READY FOR SUBSEQUENT USE AND NOT ONLY FOR THE PURPOSE OF STOCK BECAUSE THESE TERMINALS MAY BE DAMAGED (I. E. : BENT, DEFORMATION) EASILY DURING TRANSPORTATION AND STORAGE.
2. THE NUMBER OF TERMINAL CRIMPED WIRES PER BUNDLE SHALL BE BETWEEN 50 TO 100 WIRES. BUNDLE THEM WITH ELASTIC-BANDS IN ORDER TO KEEP THEM FROM BECOMING SEPARATED (SEE EXAMPLE BELOW).
3. AFTER CRIMPING, THE TERMINALS SHALL BE COVERED WITH A VINYL-BAG FOR PROTECTION (SEE EXAMPLE BELOW). THIS BAG MUST NOT BE REMOVED OR OPENED BEFORE ASSEMBLY.
4. A WIRE HANGING STAND OR A BOX WITH A LID SHALL BE USED FOR THE TRANSPORTATION OF THESE TERMINAL CRIMPED WIRES. THE WIRES MUST NOT BE STACKED.
5. DURING TRANSPORTATION, THE WIRES MUST NEVER BE THROWN TO THE GROUND OR INTO A BOX. THE BOX CONTAINING THESE WIRES MUST NEVER BE THROWN ABOUT.

EXAMPLE OF BUNDLE

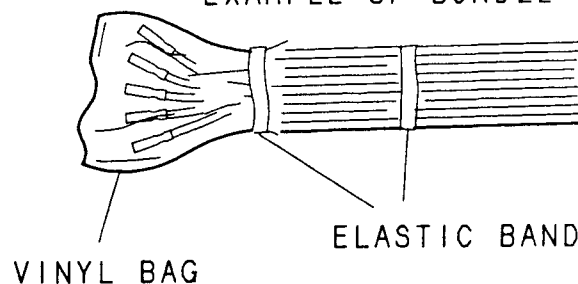

EXAMPLE OF WIRE HANGING

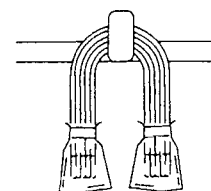
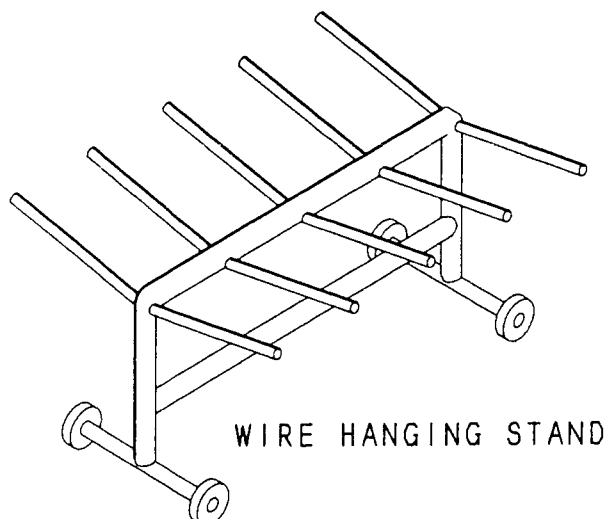

SHORT WIRES

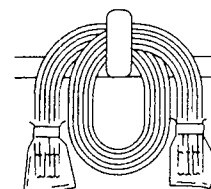

LONG WIRES

## 6. TERMINAL AND FRONT LOADED SPACER SETTING INSTRUCTIONS AND PRECAUTIONS:

### 6-1 MALE TERMINAL INSERTION INTO HOUSING:

1. AFTER MAKING SURE THAT THE FRONT LOADED SPACER IS ON THE PRIMARY LOCKING POSITION AND THAT THE ORIENTATION OF THE TERMINALS ARE PROPER (REFER TO THE PICTURE BELOW). INSERT THE TERMINALS INTO THE MALE HOUSING.
2. INSERT THE TERMINAL UNTIL A CLICKING SOUND IS HEARD FROM THE TERMINAL LOCK-UP LOCKING ONTO THE HOUSING FLEXIBEL LANCE.
3. AFTER INSERTION. PULL THE WIRE LIGHTLY TO CHECK IF THE TERMINAL LOCK-UP HAS SECURELY LOCKED ONTO THE HOUSING FLEXIBLE LANCE.

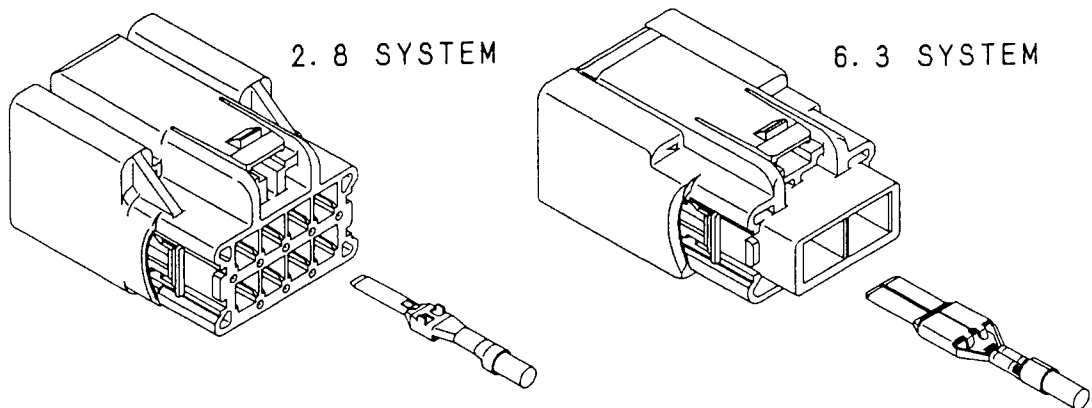

### 6-2 FEMALE TERMINAL INSERTION INTO HOUSING:

1. AFTER MAKING SURE THAT THE FRONT LOADED SPACER IS ON THE PRIMARY LOCKING POSITION AND THAT THE ORIENTATION OF THE TERMINALS ARE PROPER (REFER TO THE PICTURE BELOW). INSERT THE TERMINALS INTO THE FEMALE HOUSING.
2. INSERT THE TERMINAL UNTIL A CLICKING SOUND IS HEARD FROM THE TERMINAL LOCK-UP LOCKING ONTO THE HOUSING FLEXIBEL LANCE.
3. AFTER INSERTION. PULL THE WIRE LIGHTLY TO CHECK IF THE TERMINAL LOCK-UP HAS SECURELY LOCKED ONTO THE HOUSING FLEXIBLE LANCE.

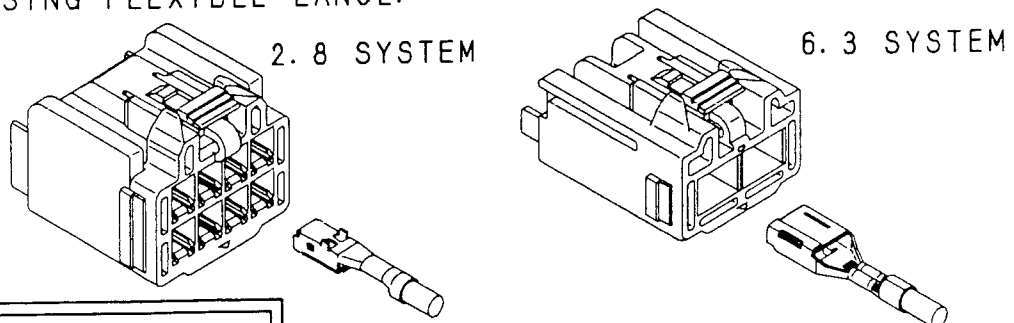

#### PRECAUTIONARY ITEM

WHEN THE FRONT LOADED SPACER IS FULLY INSERTED, THE TERMINAL MUST ONLY BE INSERTED INTO THE HOUSING AFTER FIRST RELEASING THE FRONT FOADED SPACER TO THE PRIMARY LOCKING POSITION (SEE FRONT HOLDER RELEASING ON SECTIONS 7-1 & 7-2).

## 6-3 FRONT LOADED SPACER SETTING FOR MALE CONNECTOR:

PULL THE OPERATION ARM OF THE FRONT LOADED SPACER IN THE DIRECTION OPPOSITE TO TERMINAL INSERTION AND MOVE THE FRONT LOADED SPACER TO THE FULLY INSERTED POSITION AS SHOWN BELOW.

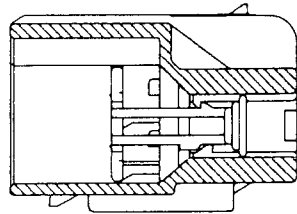

PRIMARY LOCKING POSITION

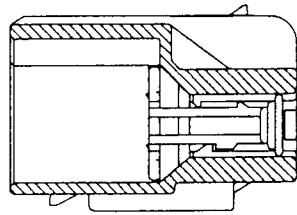

FULLY INSERTED POSITION

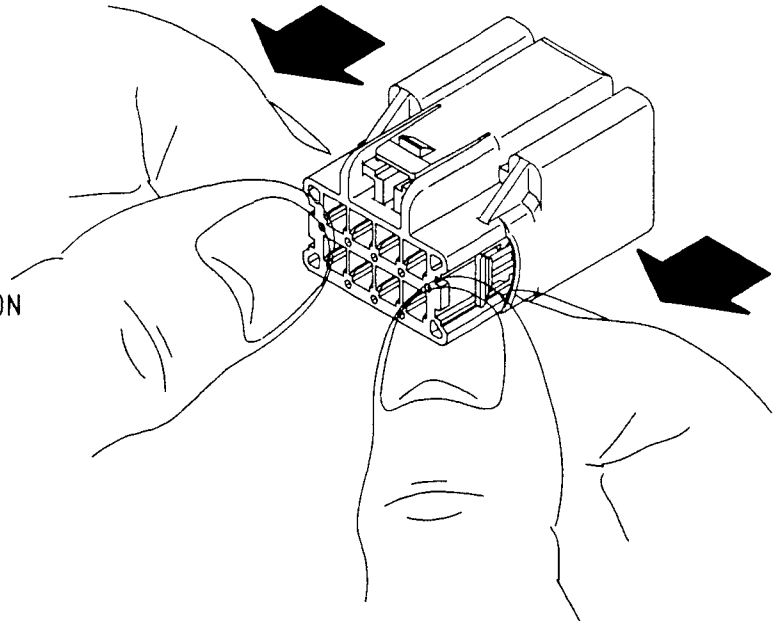

FRONT LOADED SPACER SETTING DIRECTION

## PRECAUTIONARY ITEMS

1. WHEN THE LOCKING FORCE OF THE FRONT LOADED SPACER IS HIGH OR THE FRONT LOADEDE SPACER CANNOT BE EASILY LOCKED, CHECK THE TERMINAL INSERTION AS THE TERMINALS MAY BE INCOMPLETELY INSERTED OR INSERTED IN THE WRONG DIRECTION.
2. FORCEFULLY PUSHING THE FRONT LOADED SPACER WHEN TERMINALS ARE INCOMPLETELY INSERTED MAY CAUSE DAMAGE TO THE HOUSING AND/OR THE FRONT LOADED SPACER. THEREFORE, CHECK THE TERMINAL POSITIONS AGAIN BEFORE SETTING THE FRONT LOADED SPACER TO ITS FULLY INSRTED POSITION.

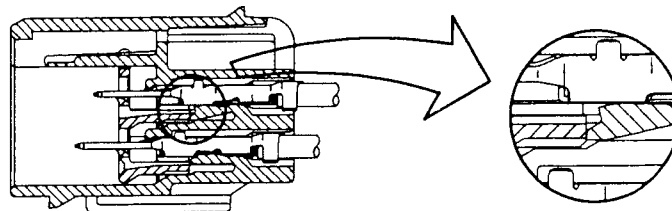

INCOMPLETE INSERTION CONDITION

3. AFTER SETTING THE FRONT LOADED SPACER, CHECK ITS LOCKING CONDITION TO AVOID HALF LOCKING AS SHOWN BELOW.

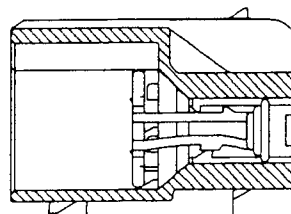

INCORRECT CONDITION

## 6-4 FRONT LOADED SPACER SETTING FOR FEMALE CONNECTOR:

PRESS DOWN THE OPERATION ARM OF THE FRONT LOADED SPACER. FIRST THEN PUSH THE FRONT LOADED SPACER TO ITS FULLY INSERTED POSITION WHILE RELEASING THE OPERATION ARM AS SHOWN BELOW.

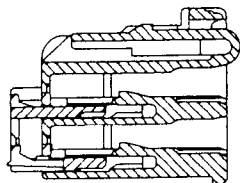

PRIMARY LOCKING POSITION

SAME PLANE

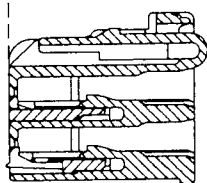

SECONDARY LOCKING POSITION

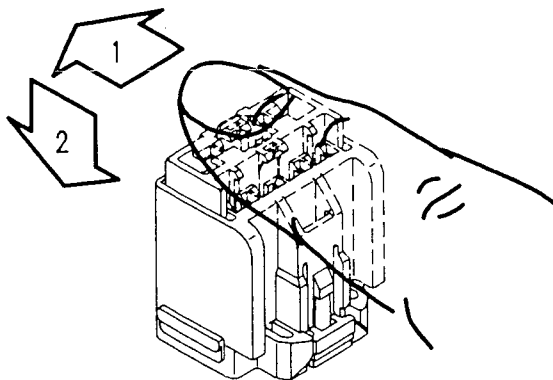

FRONT HOLDER SETTING ORDER

## PRECAUTIONARY ITEMS

1. WHEN THE LOCKING FORCE OF THE FRONT LOADED SPACER IS HIGH OR THE FRONT LOADED SPACER CANNOT BE EASILY LOCKED, CHECK THE TERMINAL INSERTION AS THE TERMINALS MAY BE INCOMPLETELY INSERTED OR INSERTED IN THE WRONG DIRECTION.
2. FORCEFULLY PUSHING THE FRONT LOADED SPACER WHEN TERMINALS ARE INCOMPLETELY INSERTED MAY CAUSE DAMAGE TO THE HOUSING AND/OR THE FRONT LOADED SPACER. THEREFORE, CHECK THE TERMINAL POSITIONS AGAIN BEFORE SETTING THE FRONT LOADED SPACER TO ITS FULLY INSERTED POSITION.

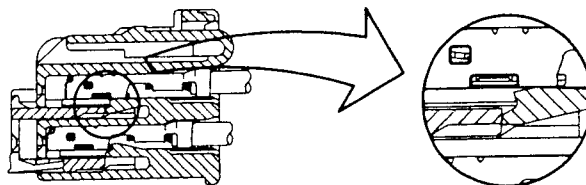

INCOMPLETE INSERTION CONDITION

3. AFTER SETTING THE FRONT LOADED SPACER, CHECK ITS LOCKING CONDITION TO AVOID HALF LOCKING AND ENSURE THAT THE FRONT LOADED SPACER IS SECURELY LOCKED BY CHECKING IF THE FRONT LOADED SPACER IS ON THE SAME PLANE AS THE FEMALE HOUSING MATING FACE AS SHOWN ABOVE.
4. DO NOT PUSH THE FRONT HOLDER WITHOUT RELEASING THE LOCKING BETWEEN THE HOUSING AND THE FRONT HOLDER VIA THE OPERATION ARM BECAUSE THE LOCKING SYSTEM CAN BE DAMAGED AND IMPAIR THE FRONT LOADED SPACER'S NORMAL OPERATING FUNCTION.

## 7. TERMINAL AND FRONT LOADED SPACER REMOVAL INSTRUCTIONS AND PRECAUTIONS:

WHEN IT IS NECESSARY TO REMOVE A TERMINAL, THE FOLLOWING PRECAUTIONS MUST BE TAKEN.

ALSO, THE TERMINALS MUST NOT BE ABLE TO BE RELEASED UNINTENTIONALLY.

### 7-1 FRONT LOADED SPACER REMOVAL FOR MALE CONNECTOR:

THE PROPER METHOD OF MOVING THE FRONT LOADED SPACER TO ITS PRIMARY LOCKING POSITION IS AS FOLLOWS:

<NOTE>

THE METHOD OF FRONT LOADED SPACER RESETTING IS AS REFERRED TO IN SECTION 6-3.

1. RELEASE THE LOCK BY PULLING THE OPERATION ARMS OF THE SPACER OUTWARD.
2. WHILE HOLDING THE OPERATION ARMS OF THE SPACER, MOVE THE SPACER TO ITS PRIMARY LOCKING POSITION.

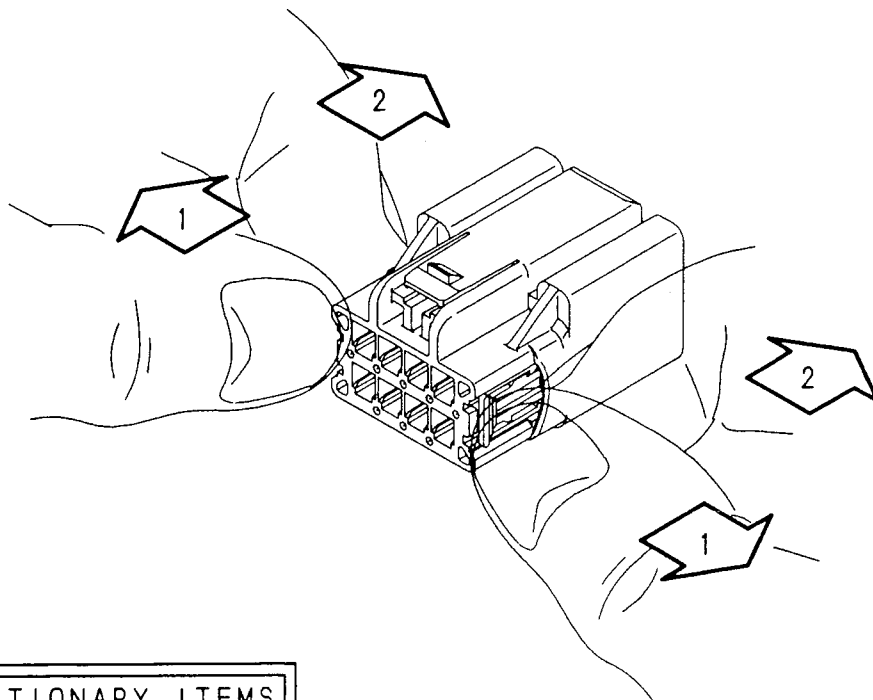

#### PRECAUTIONARY ITEMS

1. DO NOT PULL THE SPACER'S OPERATION ARMS OUTWARD EXCESSIVELY BECAUSE IT IS FEARED THAT THE OPERATION ARMS MIGHT BE DAMAGED.
2. MAKE SURE THAT THE FRONT HOLDER IS PROPERLY IN ITS PRIMARY LOCKING POSITION BEFORE ATTEMPTING TO REMOVE A TERMINAL.

## 7-2 FRONT LOADED SPACER REMOVAL FOR FEMALE CONNECTOR:

THE PROPER METHOD OF MOVING THE SPACER TO ITS PRIMARY LOCKING POSITION IS AS FOLLOWS:

<NOTE>

THE METHOD OF FRONT LOADED SPACER RESETTING IS AS REFERRED TO IN SECTION 6-4.

1. RELEASE THE LOCK BY PRESSING DOWN THE OPERATION ARM OF THE SPACER.
2. PULL OUT THE SPACER TO ITS PRIMARY LOCKING POSITION WHILE RELEASING THE PRESSURE ON THE OPERATION ARM.

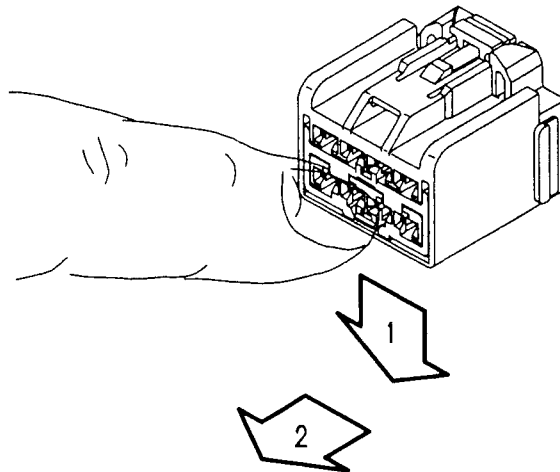
**PRECAUTIONARY ITEM**

LIGHTLY PRESS DOWN ON THE OPERATION ARM; TOO MUCH PRESSURE ON IT MIGHT CAUSE PERMANENT DEFORMATION.

## 7-3 TERMINAL REMOVAL:

THE TERMINAL REMOVAL OPERATION MUST NOT BE ATTEMPTED BY A NON-SPECIALIST WHO HAS NOT BEEN TRAINED FOR THIS OPERATION.

THE TOOL TO BE USED FOR THIS OPERATION IS SPECIFIED IN SECTION 7-3.

THIS OPERATION SHOULD ONLY BE CARRIED OUT USING THE PROPER REMOVAL TOOL. PRECISION SCREWDRIVERS MUST NOT BE USED.

THE PROPER METHOD OF REMOVING THE TERMINALS FROM THE HOUSING IS AS FOLLOWS:

## 7-3-1 MALE TERMINAL FOR 2.8 SYSTEM:

1. PUSH THE WIRE LIGHTLY IN THE DIRECTION OF TERMINAL INSERTION THEN INSERT THE REMOVAL TOOL BETWEEN THE TERMINAL AND THE HOUSING LANCE ALONG THE GUIDE HOLE OF THE FRONT LOADED SPACER AFTER ASSURING THE ORIENTATION OF THE REMOVAL TOOL. PUSH THE REMOVAL TOOL LIGHTLY TO RELEASE THE LOCK BETWEEN THE LOCK BEAK AND THE TERMINAL LOCK-UP.

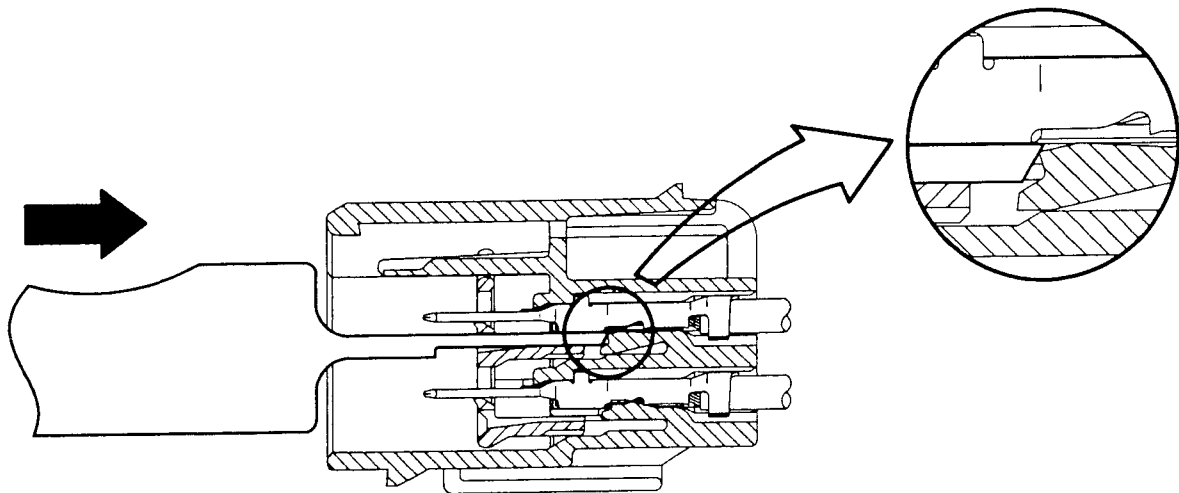

2. THEN PULL THE WIRE LIGHTLY TO REMOVE THE TERMINAL FROM THE HOUSING.

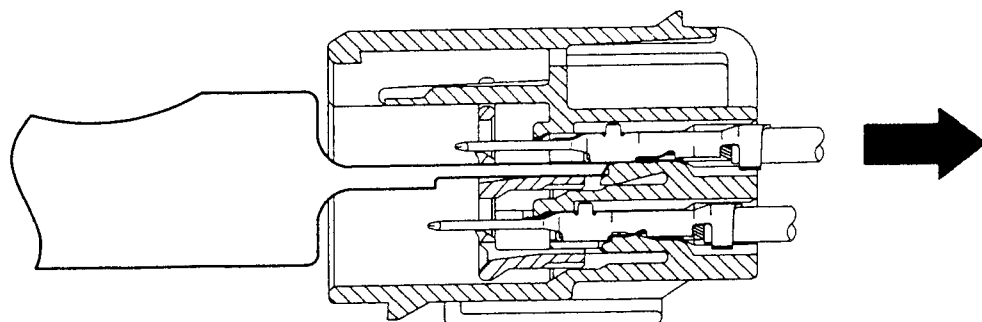



PRECAUTIONARY ITEMS

1. WHEN THE TERMINAL CANNOT BE RELEASED BY PULLING THE WIRE LIGHTLY, THE REMOVAL OPERATION DISCUSSED ON THE PREVIOUS PAGE MUST BE REPEATED.
2. CHECK THE TERMINAL AND/OR HOUSING FOR ANY DEFORMATION. IF ANY DEFORMATION IS FOUND, THEY MUST NOT BE REWORKED BUT REPLACED WITH NEW ONES.

7-3-2 MALE TERMINAL FOR 6.3 SYSTEM:

1. PUSH THE WIRE LIGHTLY IN THE DIRECTION OF TERMINAL INSERTION THEN INSERT THE REMOVAL TOOL BETWEEN THE TERMINAL AND THE HOUSING LANCE ALONG THE GUIDE HOLE OF THE FRONT LOADED SPACER AFTER ASSURING THE ORIENTATION OF THE REMOVAL TOOL.

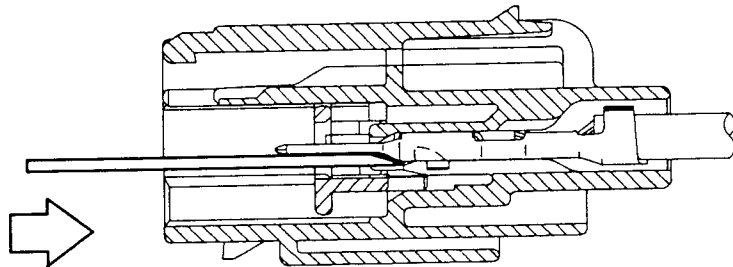

2. RELEASE THE LOCK BETWEEN THE LOCK BEAK AND THE TERMINAL LOCK-UP BY TURNING THE REMOVAL TOOL IN THE DIRECTION SHOWN IN THE DRAWING BELOW. THEN PULL THE WIRE LIGHTLY TO REMOVE THE TERMINAL FROM THE HOUSING.

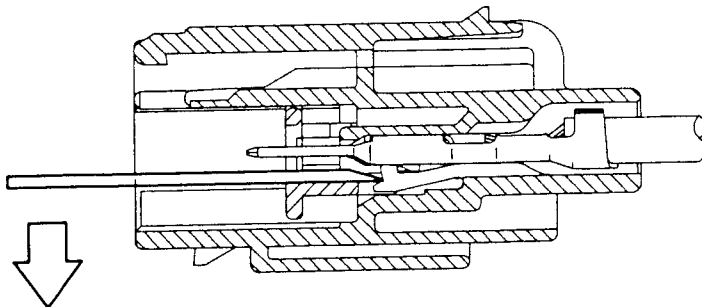

**PRECAUTIONARY ITEMS**

1. WHEN THE TERMINAL CANNOT BE RELEASED BY PULLING THE WIRE LIGHTLY, THE REMOVAL OPERATION DISCUSSED ON THE PREVIOUS PAGE MUST BE REPEATED.
2. CHECK THE TERMINAL AND/OR HOUSING FOR ANY DEFORMATION. IF ANY DEFORMATION IS FOUND, THEY MUST NOT BE REWORKED BUT REPLACED WITH NEW ONES.
3. WHEN REMOVING A TERMINAL, THE BLADE MUST NEVER BE DEFORMED BY THE REMOVAL TOOL. IF ANY TERMINAL IS DEFORMED, IT MUST NOT BE REWORKED BUT REPLACED WITH A NEW ONE.

**7-3-3 FEMALE TERMINAL FOR 2.8 SYSTEM:**

1. PUSH THE WIRE LIGHTLY IN THE DIRECTION OF TERMINAL INSERTION THEN INSERT THE REMOVAL TOOL BETWEEN THE TERMINAL AND THE HOUSING LANCE ALONG THE GUIDE HOLE OF THE FRONT LOADED SPACER AFTER ASSURING THE ORIENTATION OF THE REMOVAL TOOL. PUSH THE REMOVAL TOOL LIGHTLY TO RELEASE THE LOCK BETWEEN THE LOCK BEAK AND THE TERMINAL LOCK-UP.

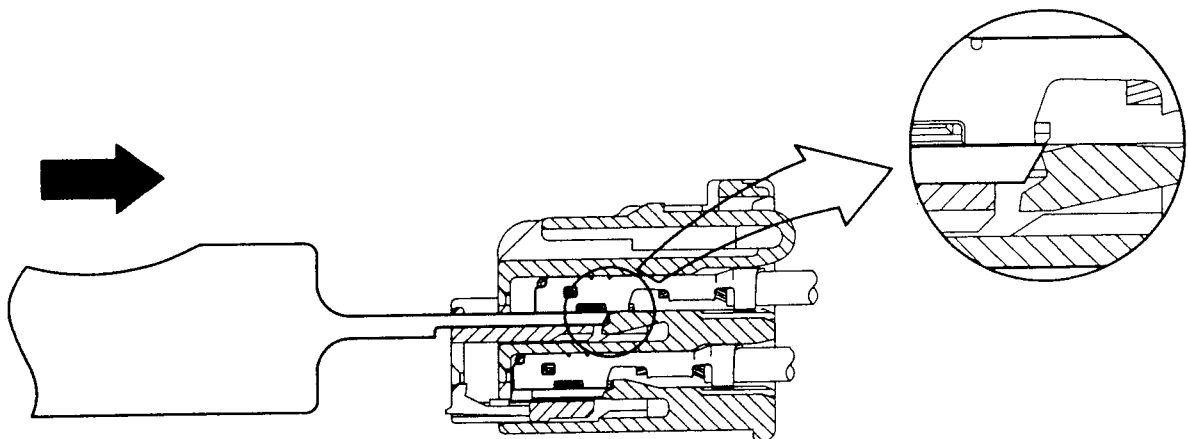

2. THEN PULL THE WIRE LIGHTLY TO REMOVE THE TERMINAL FROM THE HOUSING.

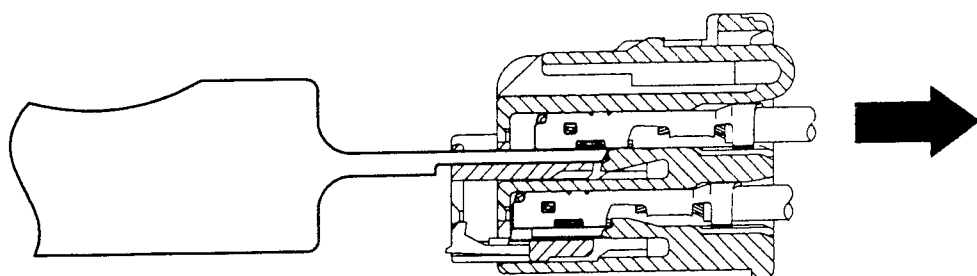

PRECAUTIONARY ITEMS

1. WHEN THE TERMINAL CANNOT BE RELEASED BY PULLING THE WIRE LIGHTLY, THE REMOVAL OPERATION DISCUSSED ON THE PREVIOUS PAGE MUST BE REPEATED.
2. CHECK THE TERMINAL AND/OR HOUSING FOR ANY DEFORMATION. IF ANY DEFORMATION IS FOUND, THEY MUST NOT BE REWORKED BUT REPLACED WITH NEW ONES.
3. WHEN REMOVING THE FEMALE TERMINAL, THE REMOVAL TOOL MUST NEVER BE INSERTED INTO THE CONTACT AREA WITH THE MALE TERMINAL.  
IF THE REMOVAL TOOL IS INSERTED INTO THE CONTACT AREA BY MISTAKE, THE TERMINAL MUST BE CHANGED WITH A NEW ONE REGARDLESS OF HOW FAR THE REMOVAL TOOL WAS INSERTED INTO THE CONTACT AREA.

7-3-4 FEMALE TERMINAL FOR 6.3 SYSTEM:

1. PUSH THE WIRE LIGHTLY IN THE DIRECTION OF TERMINAL INSERTION THEN INSERT THE REMOVAL TOOL BETWEEN THE TERMINAL AND THE HOUSING LANCE ALONG THE GUIDE HOLE OF THE FRONT LOADED SPACER AFTER ASSURING THE ORIENTATION OF THE REMOVAL TOOL.

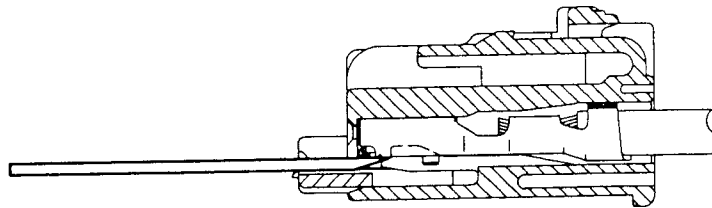

2. RELEASE THE LOCK BETWEEN THE LOCK BEAK AND THE TERMINAL LOCK-UP BY TURNING THE REMOVAL TOOL IN THE DIRECTION SHOWN IN THE DRAWING BELOW. THEN PULL THE WIRE LIGHTLY TO REMOVE THE TERMINAL FROM THE HOUSING.

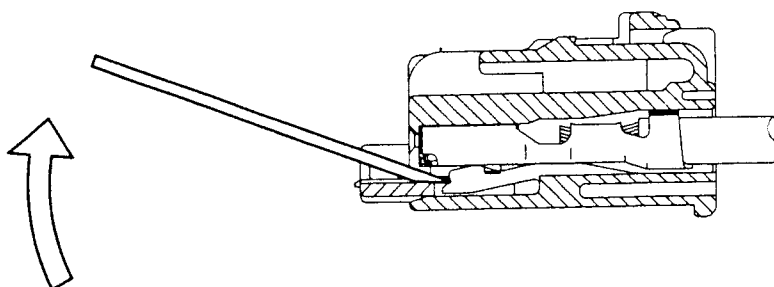

### PRECAUTIONARY ITEMS

1. WHEN THE TERMINAL CANNOT BE RELEASED BY PULLING THE WIRE LIGHTLY, THE REMOVAL OPERATION DISCUSSED ON THE PREVIOUS PAGE MUST BE REPEATED.
2. CHECK THE TERMINAL AND/OR HOUSING FOR ANY DEFORMATION. IF ANY DEFORMATION IS FOUND, THEY MUST NOT BE REWORKED BUT REPLACED WITH NEW ONES.
3. WHEN REMOVING THE FEMALE TERMINAL, THE REMOVAL TOOL MUST NEVER BE INSERTED INTO THE CONTACT AREA WITH THE MALE TERMINAL.  
IF THE REMOVAL TOOL IS INSERTED INTO THE CONTACT AREA BY MISTAKE, THE TERMINAL MUST BE CHANGED WITH A NEW ONE REGARDLESS OF HOW FAR THE REMOVAL TOOL WAS INSERTED INTO THE CONTACT AREA.

#### 7-4 SHAPE OF REMOVAL TOOLS:

1. REMOVAL TOOL FOR  
2. 8 SYSTEM CONNECTOR:

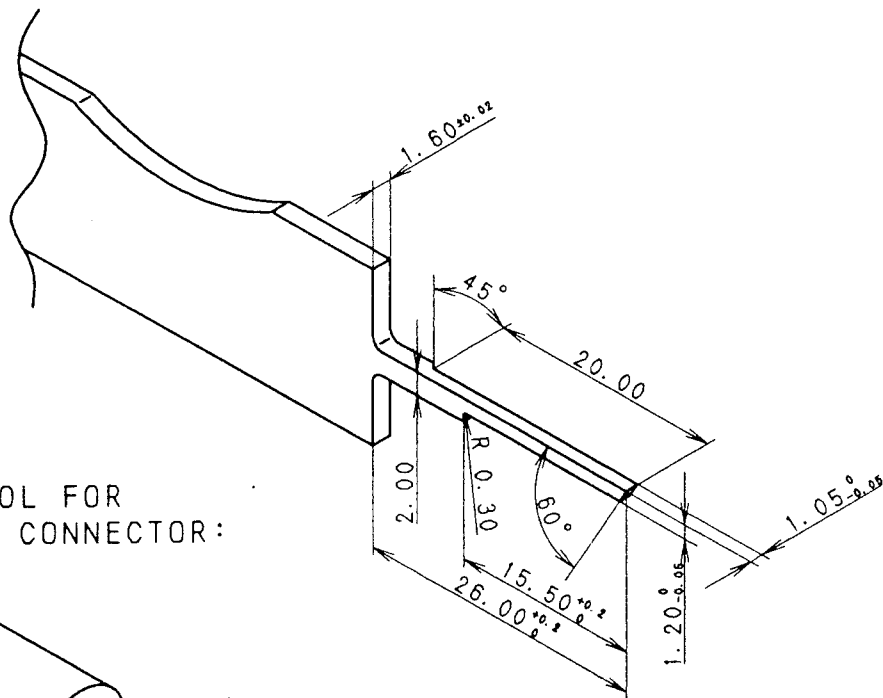

2. REMOVAL TOOL FOR  
6. 3 SYSTEM CONNECTOR:

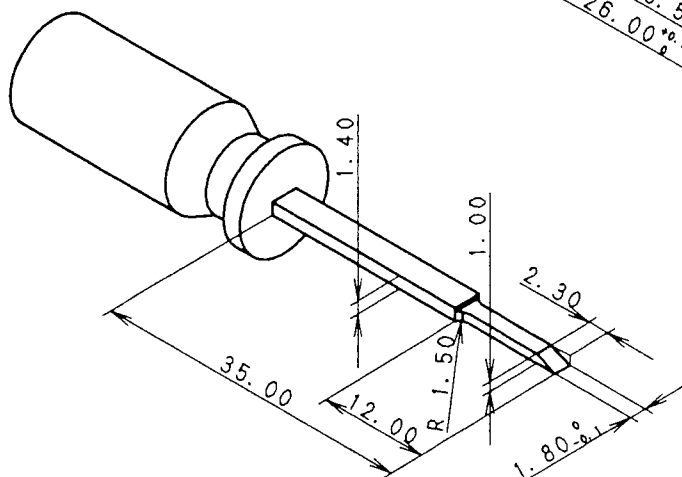

## 8. MALE CONNECTOR TERMINAL ALIGNMENT INSPECTION

THE PURPOSE OF THIS GAUGE IS TO ASSURE THE MALE CONNECTOR TERMINAL ALIGNMENT.

NO.	PART NO.	DRAWING OF GAUGE	REMARKS
1	7282-5621-40	PAGE 28 OF 34	
2	7282-5622-40	PAGE 28 OF 34	COMMON WITH GAUGES
3	7282-5623-60		
4	7282-5623-30		
5	7282-5624-90		
6	7282-5625-40	PAGE 29 OF 34	

NOTE) HANDLING OF GAUGE CONSIDERED,  
GAUGE WEIGHT SHALL BE 150g OR UNDER.

### 8-1 INSPECTION METHOD

1) CONFIRM THE COMBINATION OF GAUGES AND CONNECTORS.

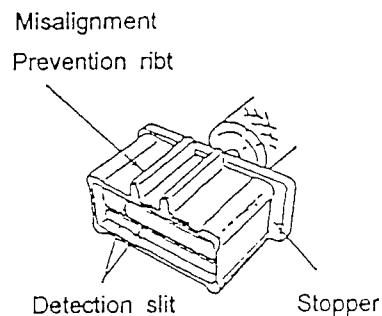

2) BEFORE INSERTING THE GAUGE, INSPECT VISUALLY THAT NO ABNORMALITY EXISTS ON TERMINAL ALIGNMENT.

#### NOTE

1. WARP WIRES UP AND DOWN AND INSPECT TERMINAL ALIGNMENT.
2. FOR THE TERMINAL ON WHICH ABNORMALITY IS DETECTED BY VISUAL INSPECTION, REPLACE IT BEFORE INSPECTION WITH GAUGE.

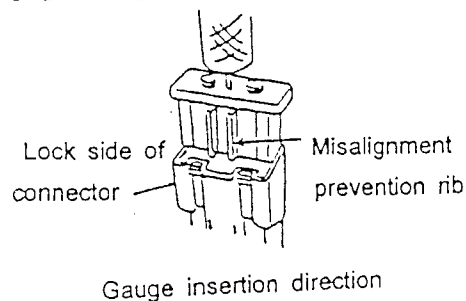

### 3) INSERT THE GAUGE INTO THE CONNECTOR HOOD.

CONFIRM THE PROPER POSITION OF THE GAUGE.  
BEND THE WIRE TO THE LOCK SIDE FOR BEING TERMINAL TIPDOWN.  
INSERT THE GAUGE ALONG THE INSIDE BOTTOM SURFACE OF THE HOOD.  
CONFIRM THE GAUGE CAN BE FULLY INSERTED WITH THE FORCE  
EQUIVALENT TO THE WEIGHT OF THE GAUGE ITSELF.

#### NOTE

IF THE TERMINAL ALIGNMENT IS NOT ACCETABLE, THE GAUGE INTERFERES  
WITH THE TERMINAL AND STOP AT THE POSITION REMAINING APPROX 4mm  
FROM THE END OF THE HOOD.  
IN CASE OF THAT, DO NOT PUSH THE GAUGE.

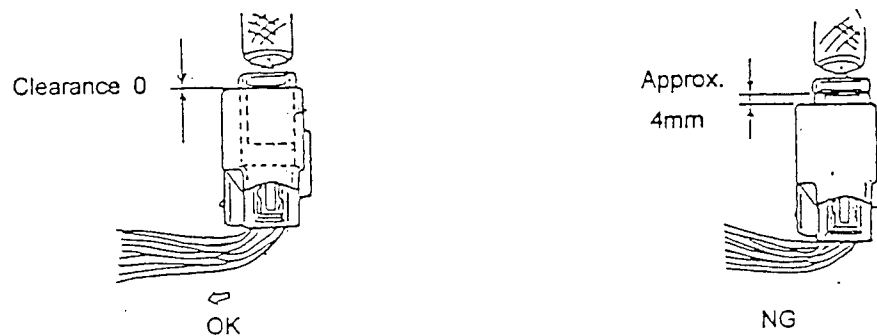

### 4) REMOVE THE GAUGE TO REINSPECT THE TERMINALS ALIGNMENT.

8-2 DRAWING OF GAUGE

NO.	PART NO.	A	B	C
1	7282-5621-40	11.10	11.80	28.20
2	7282-5622-40	18.10	18.80	35.20
3	7282-5623-60			
4	7282-5623-30			
5	7282-5624-90			

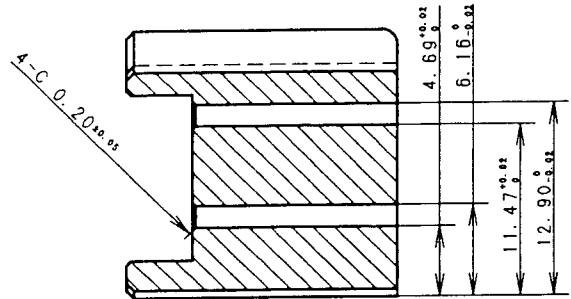
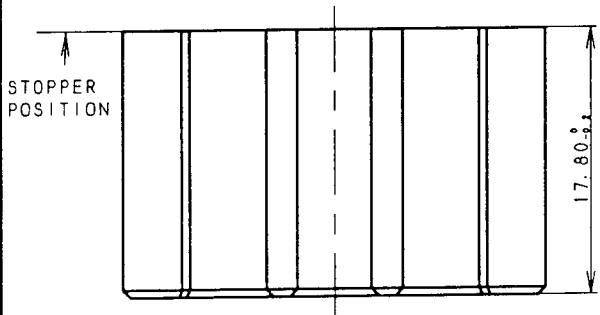

SEC. C-C  
(2.8 SYSTEM)

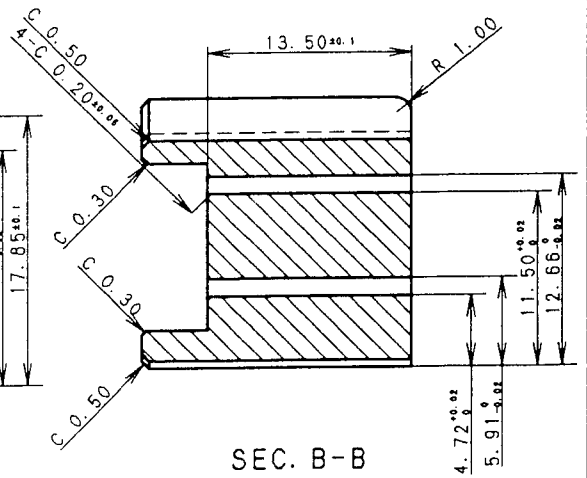
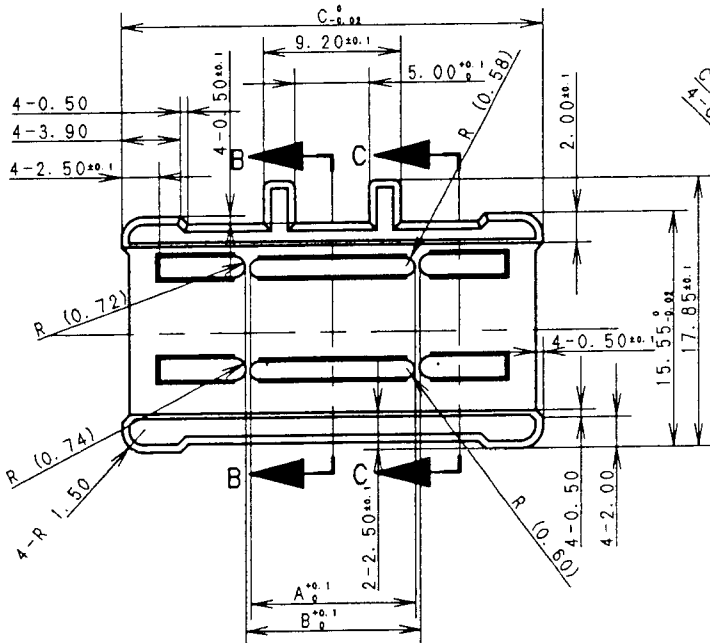

SEC. B-B  
(1.5 SYSTEM)

FOR 7282-5625-40

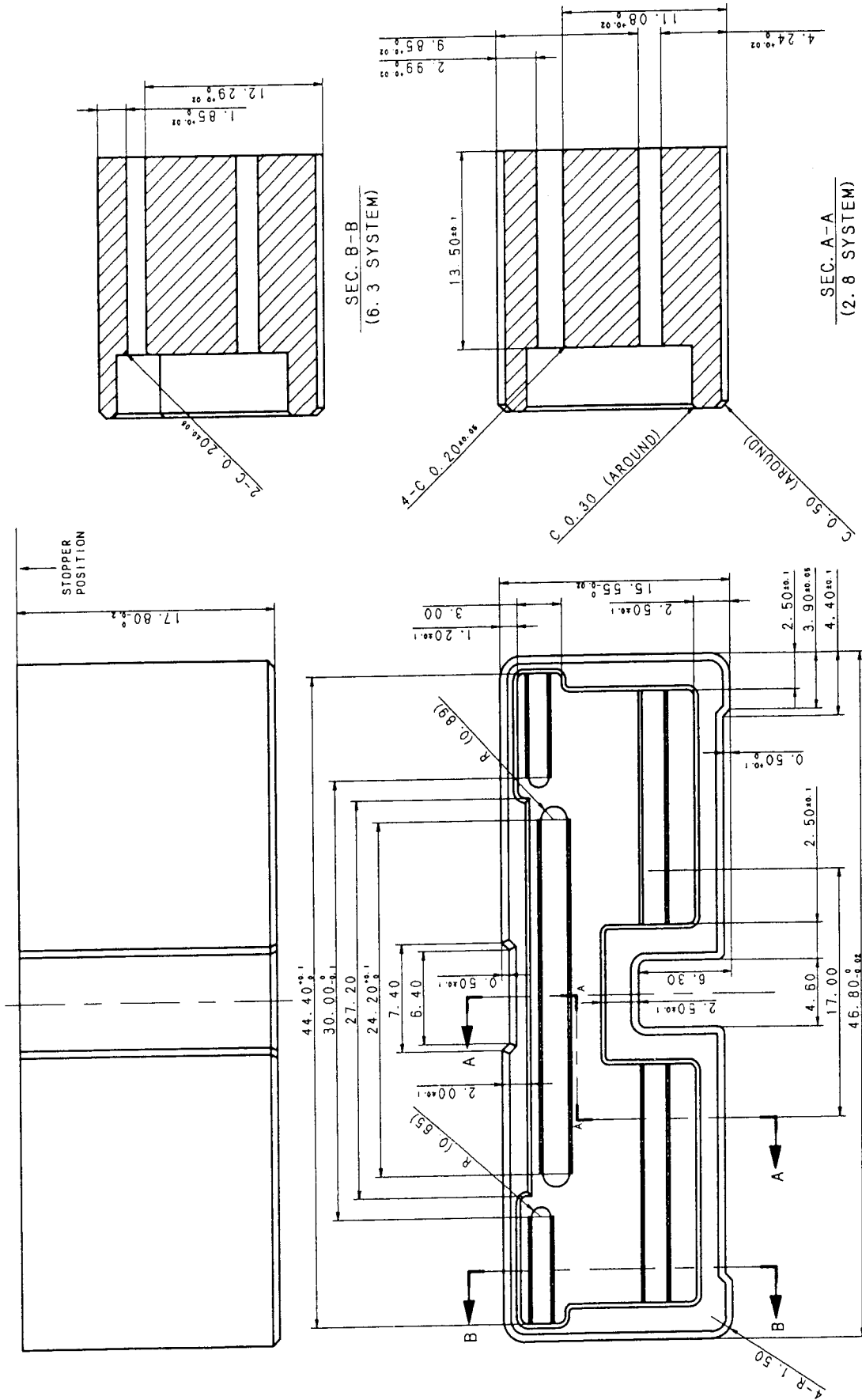



## 9. PRECAUTIONS DURING WIRING HARNESS (W/H) INSTALLATION INTO THE VEHICLE:

### 9-1 INSTALLATION INTO THE VEHICLE:

IF THE CONNECTORS ARE PASSED THROUGH A HOLE FOR INSTALLATION, THE CONNECTOR MUST NOT BE PULLED BY FORCE IN ORDER TO AVOID ANY DAMAGE.

### 9-2 CONNECTOR MATING:

MATE THE CONNECTORS WITHOUT WRENCHING AFTER THE MATING DIRECTION HAS BEEN CHECKED.  
(REFER TO THE FOLLOWING)

#### PRECAUTIONARY ITEM

THE KEY OF THE LOCKING ARM MUST NEVER BE PRESSED DOWN DURING CONNECTION.

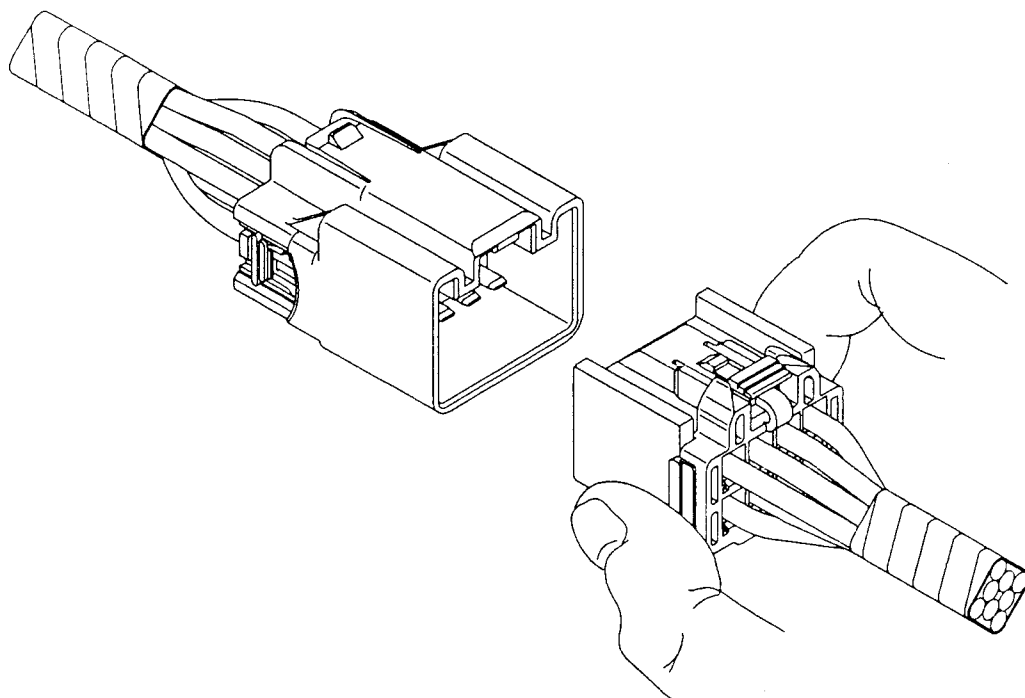

### 9-3 CONNECTOR REMOVAL:

REMOVE/SEPARATE THE CONNECTORS BY PRESSING DOWN THE KEY OF THE LOCKING ARM.

#### PRECAUTIONARY ITEM

DURING THE REMOVAL OPERATION, THE WIRES MUST NOT BE HELD AND PULLED BY FORCE.

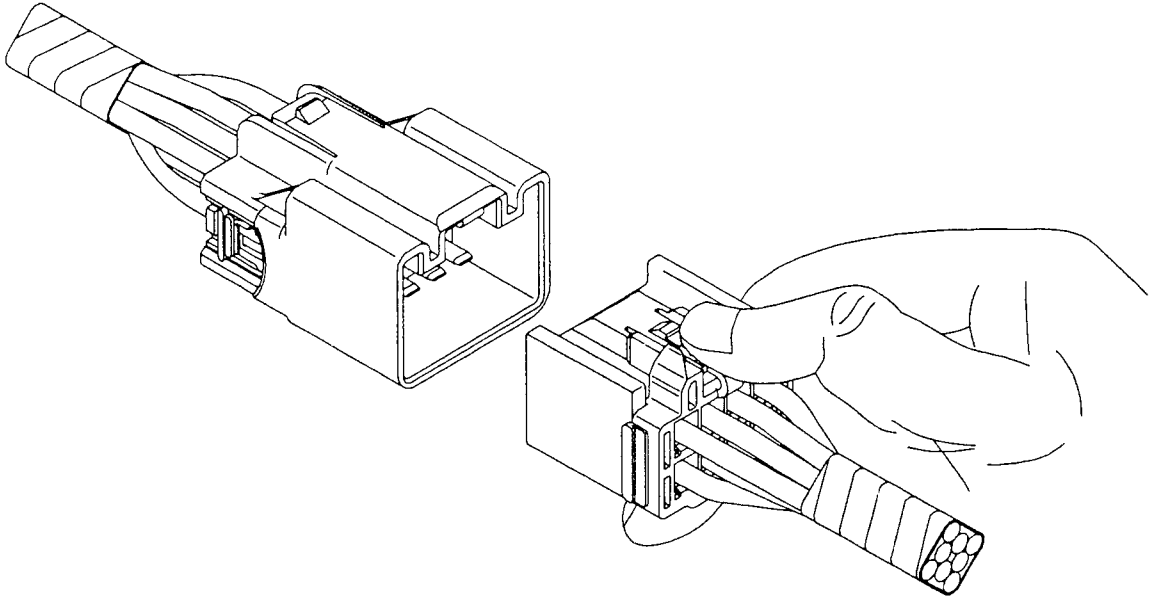

## 10. PRECAUTIONS DURING COMPLETED VEHICLE INSPECTION:

### 10-1 CONNECTOR REMOVAL:

REFER TO SECTION 9-3.

### 10-2 CONNECTOR MATING:

REFER TO SECTION 9-2.

## 11. PRECAUTIONS DURING DEALER'S SERVICE:

### 11-1 CONNECTOR REMOVAL:

REFER TO SECTION 9-3.

### 11-2 CONNECTOR MATING:

REFER TO SECTION 9-2.

## 11-3 CONNECTOR REPAIRING:

1. STRIP OFF THE TAPE OF THE W/H TO AN ADEQUATE LENGTH.

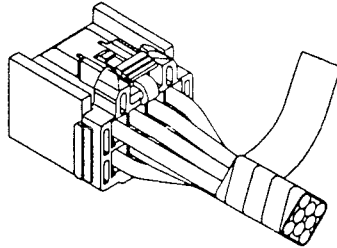

2. MOVE THE FRONT HOLDER TO ITS PRIMARY LOCKING POSITION THEN DRAW OUT THE TERMINAL TO BE REPAIRED. FOR THE FRONT LOADED SPACER AND TERMINAL REMOVAL METHOD, REFER TO SECTION 7.

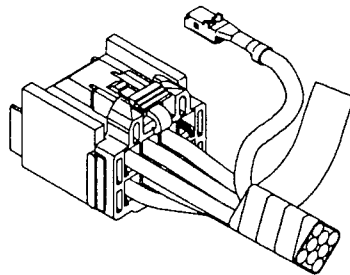

3. CUT THE WIRE OF THE TERMINAL TO BE REPLACED. STRIP OFF ABOUT 30mm OF THE WIRE INSULATION.

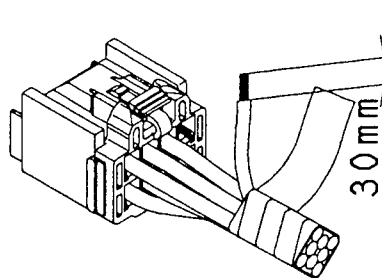

4. CONNECT A LEAD WIRE WITH A TERMINAL TO THE STRIPPED WIRE AS SHOWN BELOW THEN SOLDER THE POINT OF CONNECTION.

PRECAUTIONARY ITEM
--------------------

A LEAD WIRE WITH A TERMINAL MUST BE USED TO REPLACE THE PART.

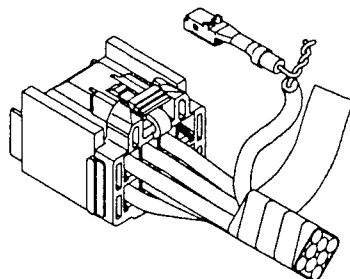

5. CUT THE ENDS OF BOTH WIRES THEN COVER THE POINT OF CONNECTION WITH A SEALING MATERIAL, ETC. AS SHOWN BELOW.

**PRECAUTIONARY ITEM**

THIS OPERATION MUST BE CARRIED OUT TO PROTECT THE WIRES FROM OXIDIZATION, ETC.

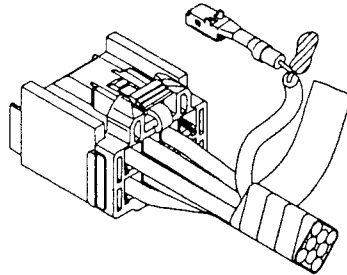

6. PUT A VINYL TUBE ON THE CONNECTION THEN TAPE IT OVER.

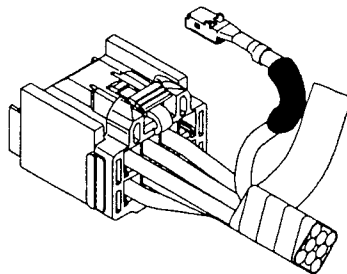

7. INSERT THE NEW TERMINAL INTO THE HOUSING THEN RESET THE FRONT HOLDER TO ITS SECONDARY LOCKING POSITION. FOR THE TERMINAL AND FRONT HOLDER RESETTING METHODS, REFER TO SECTION 6.
8. THE STRIPPED TAPE OF W/H IS WRAPPED AGAIN.

**PRECAUTIONARY ITEM**

AT THIS TIME, THE REPAIRED CONNECTION POINT MUST BE INCLUDED IN THIS TAPE WRAPPING.

9. IF THERE ARE MORE THAN ONE RECONNECTION POINTS PER CONNECTOR, THE DISTANCE BETWEEN THESE CONNECTED POINTS MUST BE AT LEAST 30mm AS SHOWN BELOW.

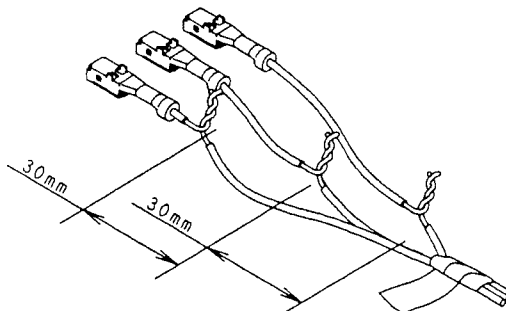

12. Notice for Packing of Wire Harness

As with many plastic parts the connector may be damaged if external force is applied to the connector during transportation or storage. To prevent damages, please take the following actions as well as the standard packaging and handling procedures:

When packing wire harness in layers, please use paper corrugate/corrugate dividers for each layer, including layer dividers, vertical dividers, internal supports, and partitions to equally distribute weights of upper-layer harnesses from being unequally applied to the lower-layer harnesses, as shown below.

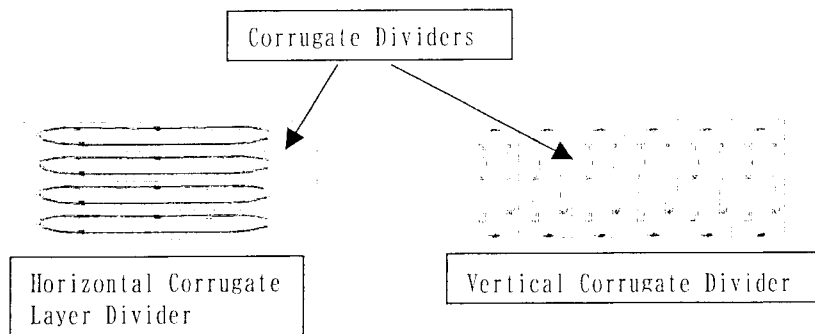

Junction block, relay box, protectors, brackets, and any heavy and/or bulky item must be placed on the bottom of the carton or the divider to prevent weight of such item from being applied to the connector as shown below.

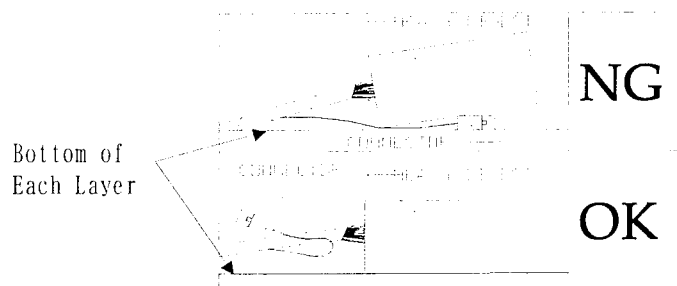

The connector must be positioned outside or in the center of the harness bundle, to prevent the weight of the harness from being applied to the connector

Sample harness sketch. Place connectors inside and outside of bundled W/H to protect connectors from weight of the W/H.

Wire harness bundle size must fit the carton to prevent shifting of wire harness during transportation or storage. See below illustration.

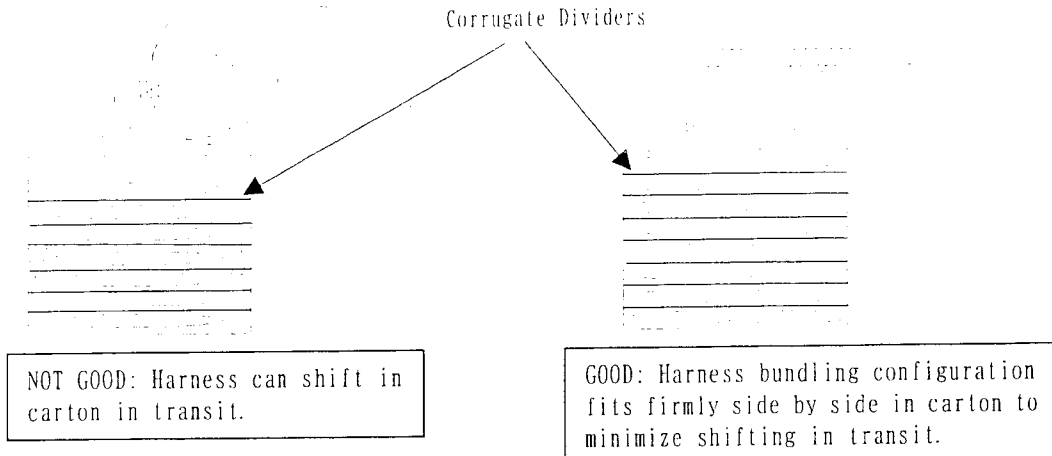

If the connector housing is 'taped back' on the wire harness bundle, assure that the housing lock or other flexible member of the connector is positioned away from the wire harness bundle. See reference illustration below.

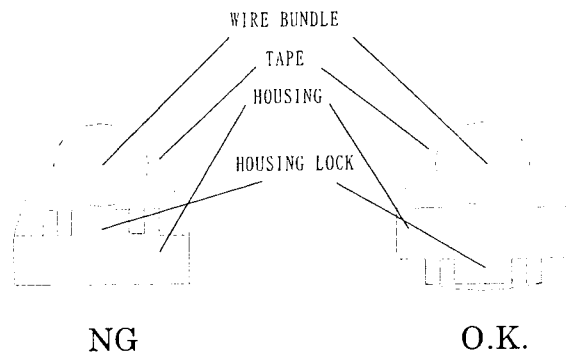

Extra care must be taken to prevent wire harnesses tangling which causes damages to the connector when the wire harness is removed from the carton at the vehicle assembly.

After transportation or storage, the connector must be checked for damages.

YAZAKI SHALL NOT BE LIABLE FOR ANY DAMAGES RESULTING FROM MISUSE OR FAILURE TO FOLLOW THE ABOVE INSTRUCTIONS