

SAFETY RECALL

SR17-85

| | | | | |
|---------|------------|-------|-----|------|
| Date | Expiration | Group | No. | Page |
| 02.2018 | NA | | | 1(6) |

X905 FUSE BOX INSPECTION
9700 (B13R)

MODEL YEAR(S) AND VEHICLE SERIAL NUMBERS (VIN) INVOLVED

| NOTICE TO SERVICE CENTERS | |
|--|--|
| Verify vehicle eligibility by checking recall status with SAP or via ONLINE WARRANTY SYSTEM available on Service / Warranty tab of PrevoSt website. | |
| Model | VIN |
| Volvo 9700 us/can Model Year : 2016 - 2018 | From 3CET2V220G5 <u>177311</u> up to 3CET2V927J5 <u>188044</u> incl. |
| This recall does not necessarily apply to all the above-mentioned vehicles, some vehicles may have been modified before delivery. The owners of the vehicles affected by this recall will be advised by a letter indicating the Vehicle Identification Number (VIN) of each vehicle concerned. | |

DESCRIPTION

On the vehicles affected by this recall, inspect fuse box X905 in the consumer I-start compartment. Refer to procedure below for further details.

MATERIAL

Order Kit **SR17-85**

| Part No. | Description | Qty |
|----------|----------------------------------|-----|
| 23066063 | M10 flanged nut, stainless steel | 2 |
| 969391 | M8 flanged nut, stainless steel | 7 |

Other parts that may be required

| Part No. | Description | Qty |
|----------|-----------------------------------|-------|
| 994913 | 80A fuse | A/R |
| 982617 | 125A fuse | A/R |
| 992454 | 80A fuse MIDI | A/R |
| 684013 | Color guard rubber coating, 428ml | 30 ml |
| 685353 | Torque seal, yellow, 1oz. tube | A/R |

PROCEDURE



DANGER

Park vehicle safely, apply parking brake, stop engine. In the battery box, set the battery cut-off switch to the OFF position prior to working on the vehicle.

PROCEDURE

1. Locate the fuse box over the road side wheel well.

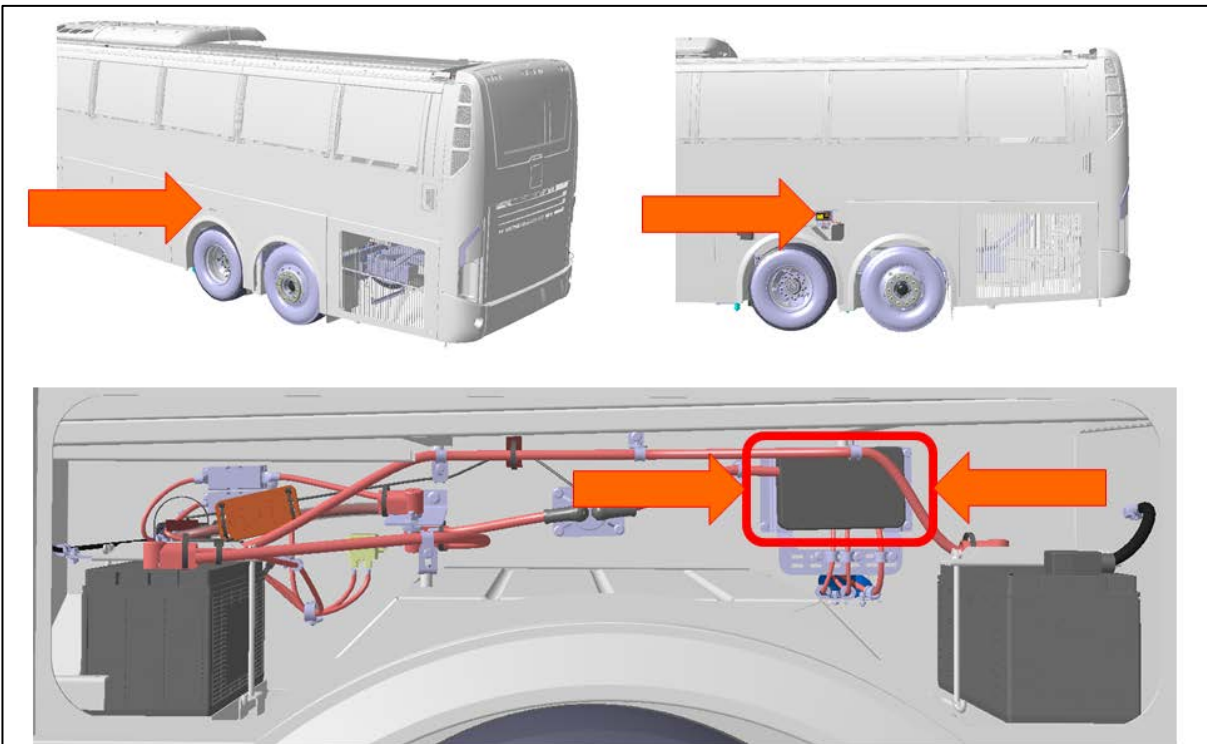

Figure 1: Fuse Box Location

- Remove the fuse box cover



Figure 2: Consumer I-Start compartment

- Check vehicle chassis number.

Vehicles **from 177311 up to 187126**, follow **STEP A** below.

Vehicles **from 187127** follow **STEP B** below.

STEP A. From chassis **177311 up to 187126**: Inspect the fuse amp rating values in the fuse box. Value should be, from left to right:

80 | 80 | 125 | 80*

Refer to **Figure 3** below.

*Note that the last **80** position may be empty. It is used only if the vehicle has a wheelchair lift.

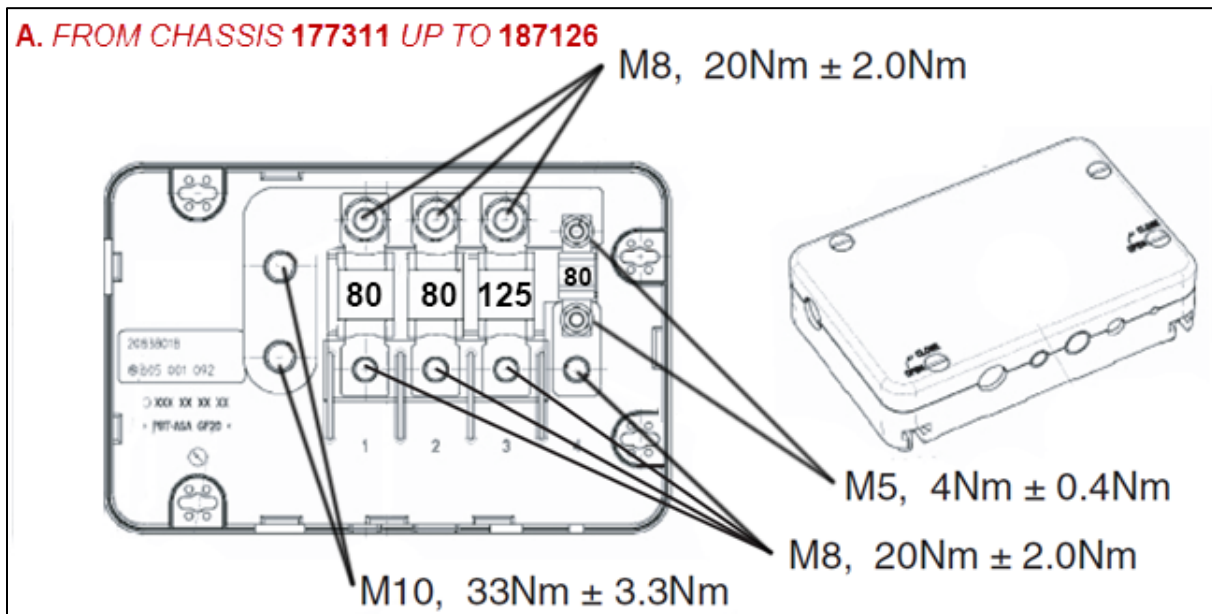

Figure 3: Stud Torques, Fuse arrangement. From Chassis 177311 up to 187126.

STEP B. From chassis **187127**: Inspect the fuse amp rating values in the fuse box.
Value should be, from left to right:

80 | 125 | 80 | 80*

Refer to **Figure 4** below.

*Note that the last **80** position may be empty. It is used only if the vehicle has a wheelchair lift.

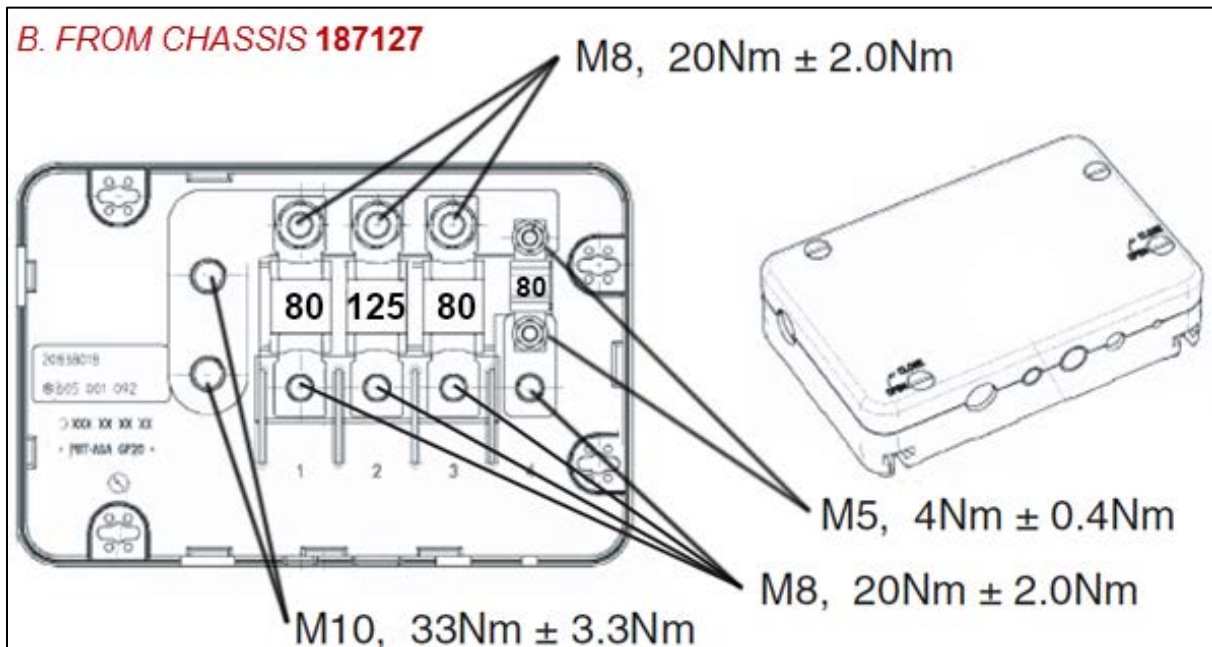

Figure 4: Stud Torques, Fuse arrangement. From Chassis 187127.

4. Replace any fuse showing heat damage.
5. Confirm the fuses have the proper rating for each position.
6. Replace as required with the following parts.
 - 994913 **80A** fuse
 - 982617 **125A** fuse
7. Tighten the connection studs to the indicated torque values shown in Figure 3 and Figure 4.
8. Apply color guard corrosion protection 684013 on all connections in the fuse box. (Figure 5)
9. Let coating dry.
10. Apply torque seal mark across nut and stud.



Figure 5: Corrosion Protection

11. Inspect the P-clamp at the left of the battery box. (Figure 6). Make sure it is secure. Position may vary.
12. Tighten to: 12 N-m (9 lb-ft)

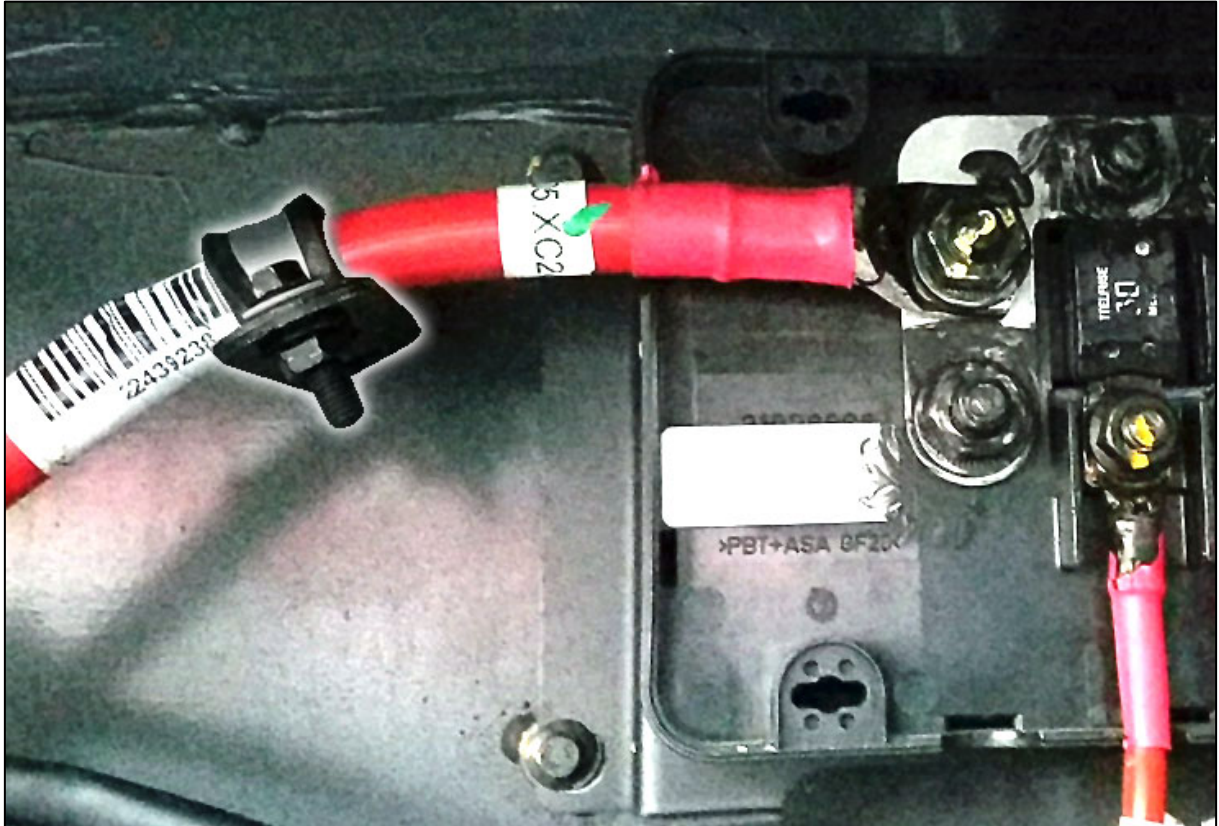

Figure 6: P-clamp on main cable. Position may vary.

PARTS / WASTE DISPOSAL

DO NOT RETURN THE REPLACED PARTS. Discard waste according to applicable environmental regulations (Municipal/State[Prov.]/ Federal)

SAFETY RECALL

SR17-85

| Date | Expiration | Group | No. | Page |
|---------|------------|-------|-----|------|
| 02.2018 | NA | | | 6(6) |

WARRANTY

This modification is covered by Prevost's normal warranty. We will reimburse you the parts and half an hour (0.5h) of labor upon receipt of a completed A.F.A. Please submit claim via our Online Warranty System, available at www.prevostcar.com (under Service \ Warranty section). Use Claim Type: "Bulletin/Recall" and select "Safety Recall SR17-85".

OTHER

| | |
|--------------|----------|
| VBC Bulletin | C5410 |
| Fail Code | 6-21 |
| Defect Code | 09 |
| Syst.Cond. | R |
| Causal Part | 22066589 |

Access all our Service Bulletins on <http://prevostparts.volvo.com/technicalpublications/en/pub.asp> or scan the QR-Code with your smart phone.

E-mail us at technicalpublications_prev@volvo.com and type "ADD" in the subject to receive our warranty bulletins by e-mail.



Prevost engages in a continuous program of testing and evaluating to provide the best possible product. Volvo Bus, however, is not committed to, or liable for updating existing products.