

SECTION 13: WHEELS, HUBS & TIRES

CONTENTS

1. WHEELS.....	3
2. WHEEL MAINTENANCE	3
2.1 INSPECTION	3
2.2 SINGLE WHEEL REMOVAL.....	3
2.3 SINGLE WHEEL INSTALLATION	4
3. DUAL WHEELS.....	4
3.1 OUTER WHEEL REMOVAL	4
3.2 INNER WHEEL REMOVAL	4
3.3 INNER WHEEL INSTALLATION	4
3.4 OUTER WHEEL INSTALLATION.....	4
3.5 INSPECTION	4
4. ALUMINUM WHEEL ANTI-CORROSION PROTECTION	4
5. WHEEL STRAIGHTNESS TEST.....	5
6. WHEEL STUDS.....	5
6.1 DRIVE AXLE STUDS.....	6
6.2 FRONT AND TAG AXLE STUDS	6
7. HUB MOUNTED WHEELS	6
7.1 CARE OF WHEELS	7
8. FRONT AND TAG AXLE WHEEL HUBS	7
8.1 HUB BEARING INSPECTION	7
8.2 HUB BEARING REMOVAL	8
8.3 HUB BEARING INSTALLATION	8
9. DRIVE AXLE WHEEL HUBS	9
9.1 BEARING ADJUSTMENT.....	9
9.2 DISASSEMBLY AND REPAIR.....	9
10. SPARE WHEEL (IF APPLICABLE)	10
10.1 PULLING OUT SPARE WHEEL.....	10
10.2 CHANGING A FLAT TIRE	11
10.3 SPARE WHEEL MAINTENANCE	11
11. TIRE MAINTENANCE	11
11.1 INFLATION PRESSURE	11
11.2 TIRE MATCHING	13
11.3 WHEEL BALANCING	13
11.4 TIRE ROTATION.....	13
12. SPECIFICATIONS	14

ILLUSTRATIONS

FIGURE 1: ALUM/STEEL WHEEL ARRANGEMENT 3
FIGURE 2: TIGHTENING SEQUENCE 3
FIGURE 3: DIAL GAUGE INSTALLATION 5
FIGURE 4: DRIVE AXLE WHEELS 6
FIGURE 5: SINGLE WHEEL 6
FIGURE 6: FRONT & TAG AXLE WHEEL HUB 7
FIGURE 7: FRONT & TAG AXLE HUB AND ROTOR ASSEMBLY 8
FIGURE 8: WARNING REFLECTORS LOCATION 10
FIGURE 9: SPARE WHEEL AND TIRE 10
FIGURE 10: TIRE INFLATION 12
FIGURE 11: TIRE LIFE / INFLATION PRESSURE 13

1. WHEELS

The vehicle is equipped with hub-mounted wheels as standard equipment, all studs and nuts have right-hand threads. Either steel wheels or optional aluminum-polished wheels may be installed on the vehicle except inner drive wheels which are always steel wheels. Both are mounted with radial tubeless tires.

Except for customer special request, all wheel dimensions are 22.50 X 9.0 inches (571.5 X 228.6 mm) for 315/80 R 22.5 "L" tires.

NOTE
 Wheel dimensions 22.50 X 10.5 (571.5 X 266.7 mm) for 365/70 R 22.5 tires are standard on VIP front and tag axles.

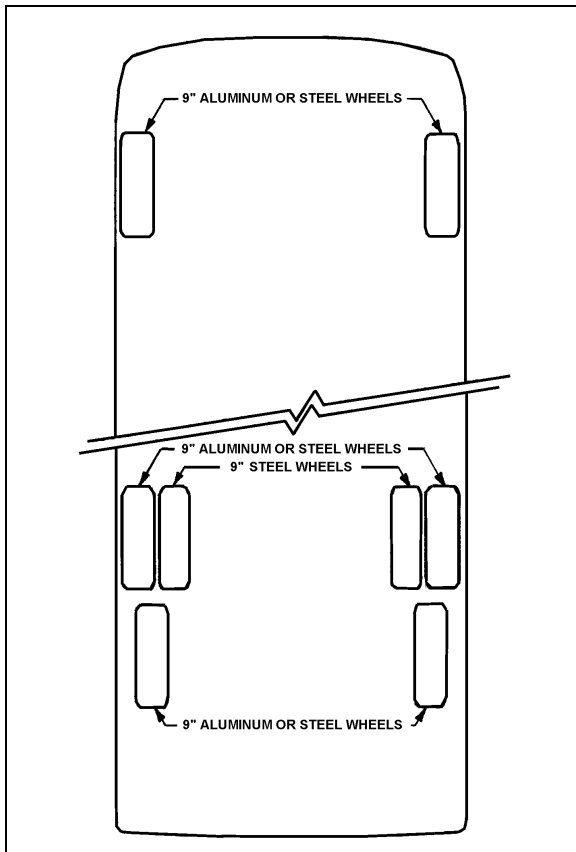

FIGURE 1: ALUM/STEEL WHEEL ARRANGEMENT 13001

2. WHEEL MAINTENANCE

Wheel maintenance consists of periodic inspections. Check all parts for damage and make sure that wheel nuts are tightened to the proper torque. In the case of a new vehicle, or after a wheel installation, stud nuts should be tightened every 100 miles (160-km) for the first 500 miles (800-km) to allow setting in of clamping surfaces.

Wheel studs and nuts must be kept free from grease and oil. No lubricant whatsoever should be used. Cleanliness of the wheel and its rotor mating surfaces is important for proper wheel mounting.

However, for hub mounted wheels, it is recommended to add some rust protection lubricant on the pilot diameter of the hub (to facilitate future removal).

It is also important that wheel stud nuts be tightened alternately on opposite sides of the wheel. Refer to Figure 2 for the suggested tightening sequence.

2.1 INSPECTION

Tighten stud nuts progressively as shown in Figure 2. The final tightening should be done with a torque wrench. Tighten stud nuts to 475±25 lbf-ft (645±35 Nm) for aluminum as well as steel wheels.

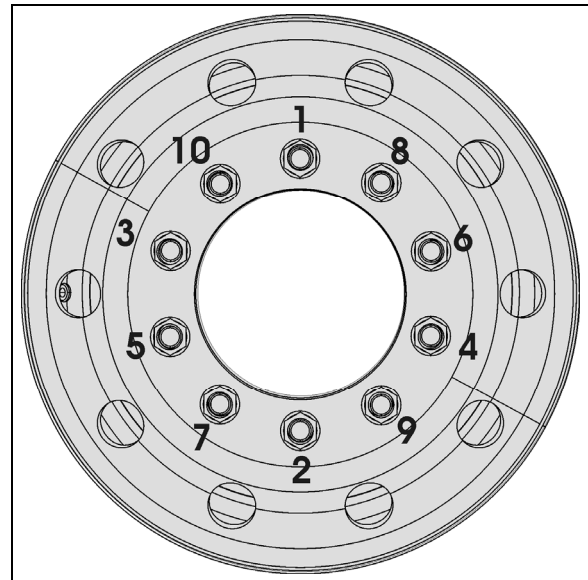

FIGURE 2: TIGHTENING SEQUENCE 13018

2.2 SINGLE WHEEL REMOVAL

1. Stop engine and apply parking brake.
2. Loosen wheel nuts about one turn (do not remove the nuts). This is not necessary if equipped with hydraulic powered gun.
3. Raise the vehicle by its jacking points on the body. See Section 18, "Body", under heading "Vehicle Jacking Points";
4. Unscrew wheel hex stud nuts and remove the wheel;



CAUTION

Always mark position of the wheel on the axle prior to removal in order to replace wheel at the same location, thus avoiding a new wheel balancing.

2.3 SINGLE WHEEL INSTALLATION

1. Mount the wheel over studs, being careful not to damage stud threads;
2. Screw in the hex stud nuts (refer to Figure 2 for sequence) so that wheel will position itself concentrically with hub. This is important, otherwise wheel may be eccentric with hub and will not run straight. In this initial step, slightly tighten the nuts to correctly position the wheel;
3. Tighten stud nuts progressively as shown in Figure 2. The final tightening should be done with a torque wrench. Tighten stud nuts to 450 - 500 lbf-ft (610 - 680 Nm) for aluminum as well as steel wheel.



CAUTION

Insufficient mounting-torque can result in damage to parts. Excessive mounting torque can cause studs to break and the wheel to crack in stud hole area.

3. DUAL WHEELS

3.1 OUTER WHEEL REMOVAL

Same as described in "Single Wheel Removal" procedure described previously.

3.2 INNER WHEEL REMOVAL

1. Remove outer wheel;
2. Remove inner wheel.

3.3 INNER WHEEL INSTALLATION

Mount the wheel over studs, being careful not to damage stud threads;

3.4 OUTER WHEEL INSTALLATION

With inner and outer wheels installed, tighten the stud nuts progressively as shown in Figure 2. The final tightening should be done with a torque wrench. Tighten stud nuts to 450 - 500 lbf-ft (610 - 680 Nm) for aluminum as well as steel wheel.



CAUTION

Insufficient mounting-torque can result in damage to parts. Excessive mounting torque can cause studs to break and the wheel to crack in stud hole area.

NOTE

On dual wheel assemblies, position the wheels with the tire valves 180° apart in order to have access to both the inner and outer valves.

3.5 INSPECTION

1. Loosen a hex stud nut three turns (Fig. 5);
2. Retighten the hex stud nut to 450 - 500 lbf-ft (610 - 680 Nm).

Repeat for each of the 10 "hex stud nuts" according to the tightening sequence in figure 2.



CAUTION

The actual length of thread engagement present in an assembled wheel can not always be determined by visual inspection of measurement of a tightened assembly. The relationship of the wheel cap nut seat to the end of the stud may vary. If there is any doubt that enough thread engagement is present, the number of engaged threads may be counted. Tighten all nuts in the regular manner, then loosen one to hand-tightness. The number of turns to disengage a 1-1/8-inch nut should be at least five full turns.

At least seven full turns should be required to disengage a 3/4-inch nut or a M22 nut. Ideally, when torqued to the proper load, the stud should be flush with the face of the nut. The face of the nut may be recessed in nuts that are taller for improved wrenching. With most of the nuts in present use, a few unengaged threads at the outer end will cause no problem provided at least 5-7 full turns are required to disengage the nut depending on thread size.

4. ALUMINUM WHEEL ANTI-CORROSION PROTECTION

Clean wheels often by means of a high pressure water jet. Cleaning may be accelerated with mild soap. Do not use concentrated alkaline cleaning products.

When tire is removed, clean and inspect wheel thoroughly. Remove dirt and corrosion on rim by means of a wire brush. Do not use a wire brush on the outer surface of the wheel.

The following measures should be taken to maintain original appearance of the aluminum wheels:

1. Remove any tar from wheel surface with a good quality tar remover.
2. Spray Alcoa Cleaner (Prévost #683529) evenly on cool outer surface of wheel. Let work 15-20 minutes (keep wet by spraying more Cleaner if necessary).
3. Rinse thoroughly with clean water and let air dry. Heavy oxidation may require a repeat application of cleaner.
4. Apply Alcoa Polish (Prévost #683528) sparingly to a small area using a clean, soft cloth. Work polish into surface as you would a rubbing compound.
5. Buff, turning cloth frequently, until surface is clean and shiny. Let air dry. Use power buffer to improve ease of use and gloss uniformity.
6. On completely dry, clean and polished surface, generously apply Alcoa sealant (Prévost #683527). Rinse thoroughly with water while surface is still wet in appearance (have water source ready as the dry time is very short, usually less than 2 minutes).
7. For best results, finish by wiping the surface with a clean rag to remove excess water, then allow surface to dry.

Clean aluminum wheels as required to maintain original look.



WARNING

Wheel surfaces may have sharp or cutting edges that may cause injury to the hands. To prevent contact with sharp edges, it is strongly recommended to wear rubber gloves when washing or polishing wheels.

5. WHEEL STRAIGHTNESS TEST

1. Slightly raise axle to be checked and place a safety support underneath;
2. Check wheel lateral run-out. Install a dial gauge as shown in figure 3, then rotate the

wheel by hand one full turn. As the wheel turns, note any variation on the dial gauge;



CAUTION

Damage to the dial gauge could occur if it strikes a wheel balancing weight.

3. If the variation in lateral run-out exceeds 0.0625 inch (1,6 mm), the wheel must be replaced.

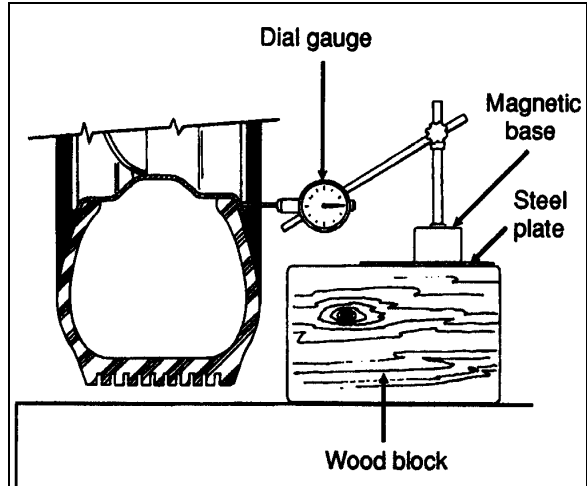



FIGURE 3: DIAL GAUGE INSTALLATION 13008

If doubt exists whether wheel or hub is distorted, hub may be checked as follows:

- Replace the existing wheel with a wheel known to be correct;
- Check wheel lateral run-out as outlined in step 2;
- If, within specifications, the hub is correct but the suspected wheel must be replaced.



WARNING

NEVER STRAIGHTEN ALUMINUM WHEELS. Never heat aluminum wheels to repair damages incurred after hitting a curb or resulting from other causes. The special alloy in wheels has been heat treated, and any uncontrolled heating could alter wheel structure. Furthermore, never weld aluminum-forged wheels for any reason whatsoever.

6. WHEEL STUDS

Stripped threads may be the result of excessive torquing or may have been damaged during wheel installation when placing the wheel over the studs.

Section 13: WHEELS, HUBS & TIRES

A stud having damaged threads must be replaced. Broken studs are a direct result of operating with loose stud nuts or improperly seated wheels. When a broken stud is replaced, the adjacent studs, on each side of the broken one must also be replaced since they could have been subjected to excessive strain and may be fatigued.

When installing wheel studs to hubs, check nuts retaining the wheel stud to wheel hub and replace if they are deformed, damaged or severely corroded. Install nut (and washer where applicable) to new stud. Torque to 450 - 500 Ft-lbs (610 - 680 Nm).

6.1 DRIVE AXLE STUDS

Hub-mounted wheels are mounted with M22 x 1.5 studs and an M22 flange nut.

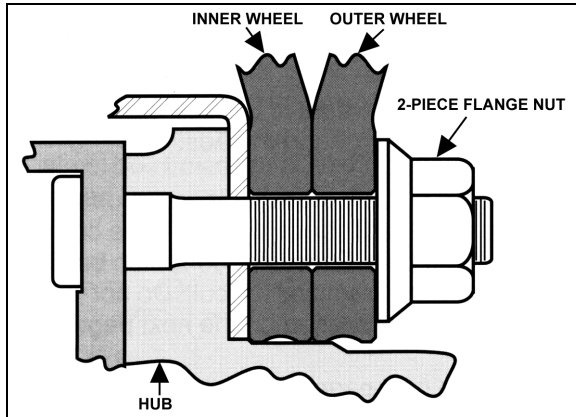

FIGURE 4: DRIVE AXLE WHEELS 13007

6.2 FRONT AND TAG AXLE STUDS

Wheel is hub mounted on front and tag axle (M22 x 1.5 thread).

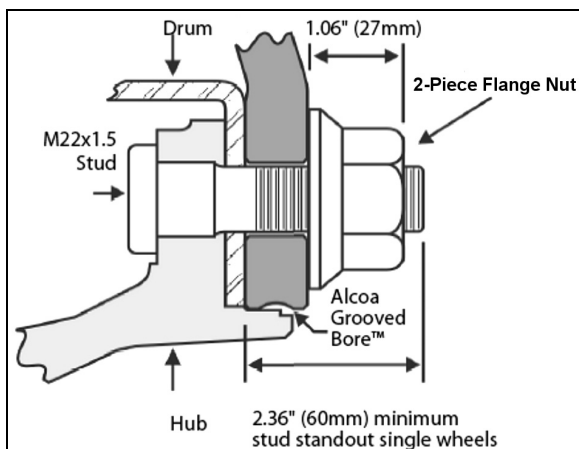

FIGURE 5: SINGLE WHEEL 13025

NOTE

Wheel studs and nuts must be kept free from grease and oil. No lubricant whatsoever should be used.

7. HUB MOUNTED WHEELS

Wheel surfaces in contact with hubs, nuts or other wheels should be kept free of all rust, grease and paint (except for initial "E" coat protection, applied to stop rusting and to facilitate wheel removal). The reason for this is to assure that all faces are clamped together without buildup of any coating. The threads of the wheel studs and the wheel nuts should be clean and undamaged.

NOTE

When painting wheels, make sure to mask all surfaces identified above.

Using a calibrated torque wrench, tighten wheel nuts to 450 - 500 lbf-ft (610 - 680 Nm) of torque. Do not use power tools or long bars for tightening. Tighten wheel nuts alternately as shown in figure 2.

NOTE

Tightening should not be done immediately after prolonged braking or when wheel ends are hot.

Check wheel nut torque at every 100 miles (160 km) for 500 miles (800 km) after fitting wheels. Let cool before checking. If any relaxation of the initial 450 - 500 lbf-ft (610 - 680 Nm) of torque has occurred, retighten. Relaxation of initial torque may occur because of the "bedding down" of the hub and wheel surfaces.

NOTE

Torque relaxation occurs when wheel ends are hot but should revert to original setting when cool. Retightening when hot will produce a higher torque reading than recommended.

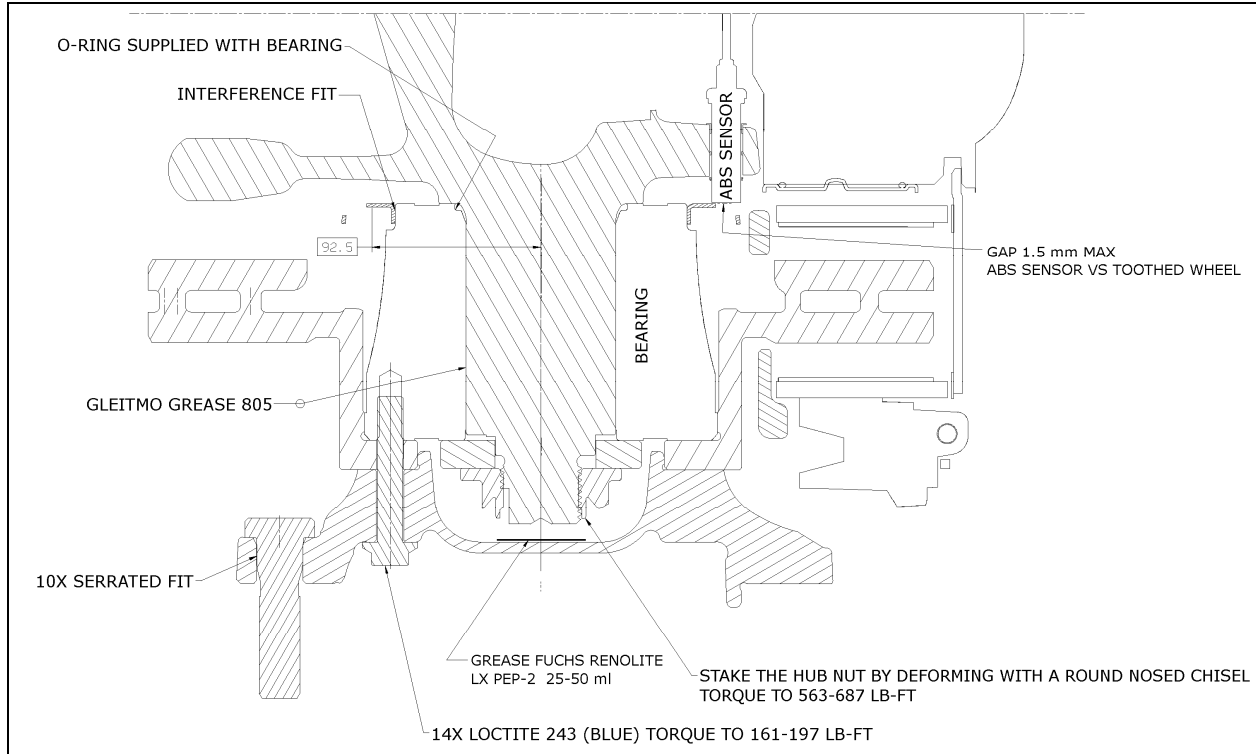

FIGURE 6: FRONT & TAG AXLE WHEEL HUB

7.1 CARE OF WHEELS

Check for cracks in wheels, especially around the fixing holes, studs, nuts and washers. If in doubt, renew.

Do not simply retighten very loose wheel fixings or wheels that are continually becoming loose. Find out why they are loose and whether any damage has been caused.

Use trained personnel and keep records of all attention to wheels and fixings, including which parts were renewed and when.

8. FRONT AND TAG AXLE WHEEL HUBS

The unitized hub bearings used on the NDS range of axles, are non-serviceable items. Bearings are pre-adjusted, lubricated and have seals fitted as part of the manufacturing process. The bearings are greased for life and there is no need or facility for re-lubrication.

8.1 HUB BEARING INSPECTION



MAINTENANCE

An inspection should be made at intervals of 30,000 miles (48 000 km) or once a year whichever comes first.

- Apply parking brake, raise wheels off the ground and support axle on stands. When the wheels are raised, they should revolve quite freely without roughness.
- Place magnetic base of a dial indicator on brake caliper and position dial indicator stem against a convenient marked spot on face of hub flange.
- With dial indicator in position pull hard but steadily on hub flange and oscillate at same time until a steady reading is achieved.
- Without releasing the pressure, turn bearing so that dial indicator stem contacts marked spot and note reading on indicator.
- Push bearing flange hard and oscillate as before until a steady reading is achieved.
- Without releasing the pressure, turn bearing so that indicator stem again contacts the marked spot and note new reading on indicator.
- The difference between readings is the amount of mounted end play in bearing unit.
- The mounted end play figure should not exceed 0.004" (0.105mm) for a new bearing in a used hub and 0.008" (0.20mm) for a bearing which has been in service.

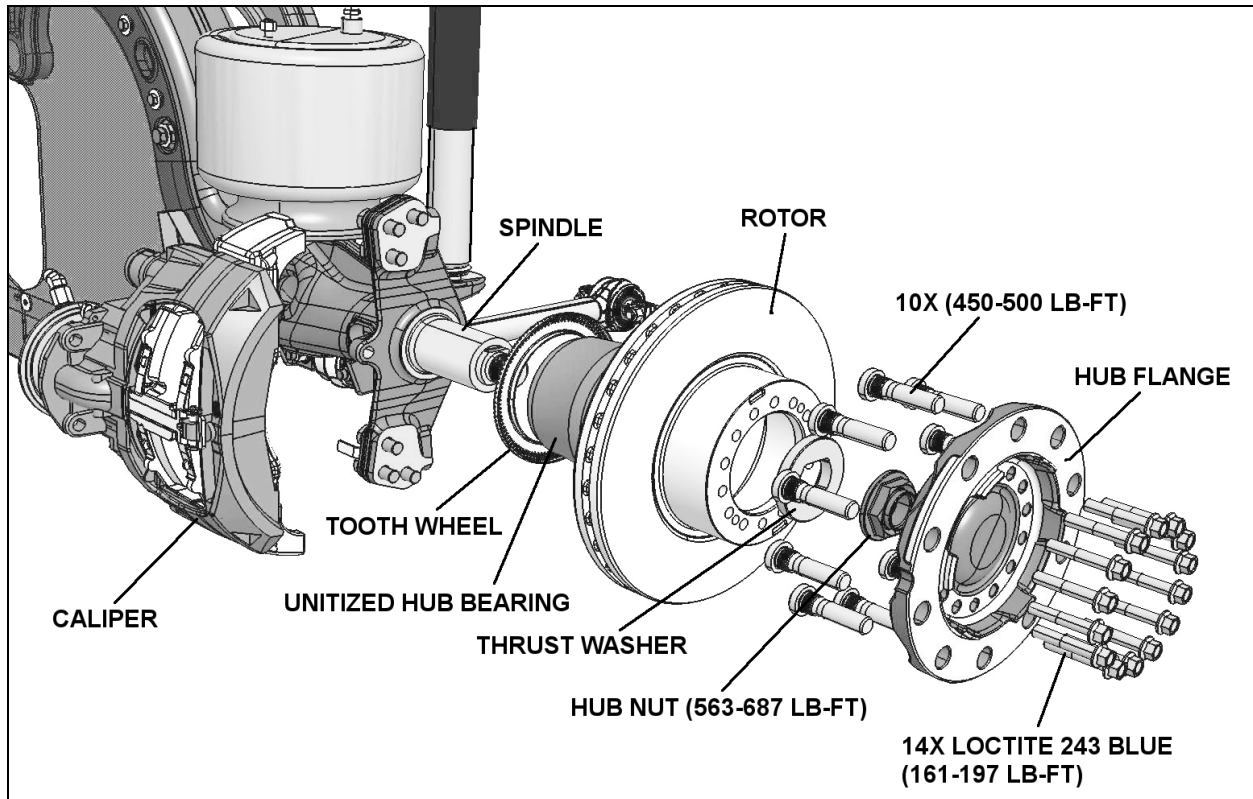

FIGURE 7: FRONT & TAG AXLE HUB AND ROTOR ASSEMBLY

NOTE

If original bearing unit is re-fitted, and end-float is measured at 1 mm, with hub not fully tightened to correct torque [563-687 lb-ft (763-931 Nm)], then the retaining clip within the unit is damaged and a new unit must be fitted.

NOTE

For more information on front and tag axle wheel hub, refer to "DANA SPICER Maintenance Manual Model NDS and Maintenance Manual NDS Axles" annexed at the end of Section 11.

8.2 HUB BEARING REMOVAL

- Stop engine and apply parking brake.
- Loosen wheel nuts about one turn (do not remove the nuts). This is not necessary if equipped with hydraulic powered gun.
- Raise the vehicle by its jacking points on the body. See Section 18, "Body", under heading "Vehicle Jacking Points".
- Unscrew wheel hex stud nuts (10) and remove the wheel.
- Unscrew hub flange hex cap screws (14).

- Remove hub flange and rotor.
- Unscrew hub nut.
- Remove hub nut and thrust washer.
- Remove unitized hub bearing by hand or use a puller if necessary.

8.3 HUB BEARING INSTALLATION

- Clean spindle using EFX degreaser (Prevost #685313).
- Lubricate part of spindle where bearing will be located, use Gleitmo 805 grease (Prevost #685274).
- Slide unitized hub bearing over spindle and position using insertion tool #32950.
- Clean thrust washer and hub nut using EFX degreaser.
- Install thrust washer and hub nut then torque hub nut to [563-687 lb-ft (763-931 Nm)].
- Stake the hub nut by deforming with a round nosed chisel.
- Clean hub bearing, rotor and hub flange clamping surfaces using EFX degreaser.
- Install rotor onto hub bearing.

- Add some grease (25-50 ml) (Fuchs Renolite LX PEP-2) (Prevost #685325) into the bottom of the hub flange cap. Mount hub flange onto rotor.
- Apply some Loctite 243 blue onto cap screw threads then secure hub flange and rotor to unitized hub bearing using cap screws (14). Torque to [161-197 Lb-Ft (218-267 Nm)] (Refer to figure 2 for tightening sequence).
- Mount the wheel over studs, being careful not to damage stud threads.
- Screw in the hex stud nuts (refer to Figure 2 for sequence) so that wheel will position itself concentrically with hub. This is important, otherwise wheel may be eccentric with hub and will not run straight. In this initial step, slightly tighten the nuts to correctly position the wheel.
- Tighten stud nuts progressively as shown in Figure 2. The final tightening should be done with a torque wrench. Tighten stud nuts to [450 - 500 lbf-ft (610 - 680 Nm)] for aluminum as well as steel wheel.

9. DRIVE AXLE WHEEL HUBS

Drive wheels use a single oil-seal assembly. They are lubricated from the oil supply in the differential housing. Bearings are tapered rollers, adjustable to compensate wear. Maintain differential oil level with general-purpose gear lubricant (refer to Section 24 "Lubrication" for proper oil grade selection) to ensure adequate oil supply to wheel bearings at all times.

9.1 BEARING ADJUSTMENT

To adjust drive wheel bearings:

1. Raise vehicle until both dual wheels can be turned freely (approximately 6 inches from the ground). Position jack stands under drive axle, then lower vehicle approximately 2 inches in order to avoid entire weight of the axle being supported by the suspension air bellows and the shock absorber pins.
2. Remove axle shaft as indicated in "Meritor - Maintenance Manual No. 5" under heading "Single Reduction Differential Carriers" annexed to "Section 11" of this manual. Remove gaskets. Unscrew lock nut and remove adjusting nut lock ring.
3. To adjust, tighten adjusting nut until the wheel binds. Rotate the wheel while tightening so that all surfaces are in proper contact. Back off adjusting nut approximately, 1/4 to 1/3 turn to assure 0.001/0.007" (0.0254/0.1778 mm) endplay and to ensure that wheel turns freely. Replace the lock ring, and adjust nut dowel pin in one of the holes. The ring may be turned over if necessary to allow more accurate bearing adjustment.
4. Tighten lock nut and check bearing adjustment. Replace the axle shaft using a new gasket.

9.2 DISASSEMBLY AND REPAIR

1. Jack vehicle as per "Bearing Adjustment" and remove axle shaft as indicated in "Meritor - Maintenance Manual No. 5" entitled "Single Reduction Differential Carriers" annexed to Section 11 of this manual.
2. Remove wheels and tires.



CAUTION

To replace wheel at the same location, always mark position of the wheel on the axle before removal, thus avoiding a new wheel balancing.

3. Remove lock nut, lock ring and adjusting nut from axle housing to prevent the outer bearing from falling out. Remove outer bearing cone and roller assembly.
4. Remove screws attaching inner oil seal retainer to hub, and remove inner oil seal assembly. Remove inner bearing cone and roller assembly. Bearing cups can be separated from the hub using a hammer and a long brass drift.
5. Thoroughly clean all parts. Bearing cone and roller assemblies can be cleaned in a suitable cleaning solvent using a stiff brush to remove old lubricant.
6. In case that excessive wear, deterioration, cracking or pitting is present on the bearing cups, rollers or cones, the bearings should be replaced. Seals should be replaced each time they are removed from the hub. To install new oil seal, use a suitable adapter and drive the seal into the retainer bore until it bottoms.
7. When installing wheel on spindle, center the wheel hub with spindle to avoid damaging the seal with the end of the spindle. Push wheel straight over the spindle until inside diameter of seal press fits on wiper ring. Fill hub cavity with general-purpose gear lubricant (refer to Section 24 "Lubrication" for proper oil grade

Section 13: WHEELS, HUBS & TIRES

selection). Lubricate, then install outer bearing cone. Adjust bearing and lock.

8. Assemble axle flange to axle using a new gasket. Apply sealant in stud area. After both wheels have been assembled according to above procedure, fill the differential with the recommended lubricant to the proper factory recommended level.

NOTE

During regular inspection, do not forget to check lubricant level in differential. Clean thoroughly or replace vent as required.

10. SPARE WHEEL (IF APPLICABLE)

Tire failure is a rare event if tires are properly cared for. In case of a flat tire, move vehicle a safe distance away from traffic and apply parking brake. Remember to use the hazard flashers and according to the Highway Code regulations, set up the triangular reflectors (see "Emergency Warning Reflectors" in the Operator's Manual) at an adequate distance, to warn incoming motorists. This kit is located at the ceiling of the forward baggage compartment, on the R.H. side.

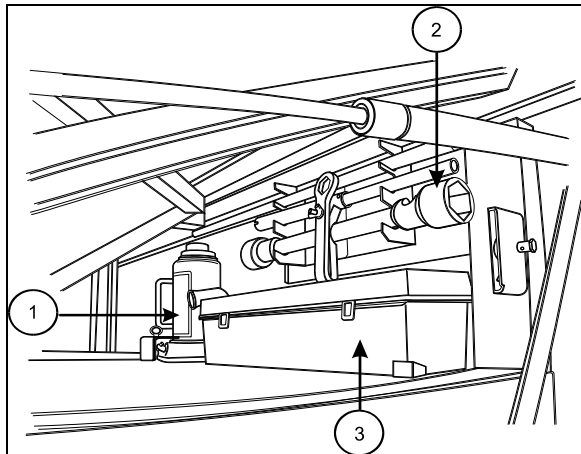

FIGURE 8: WARNING REFLECTORS LOCATION 23376

The spare wheel is stored in a dedicated compartment behind the front bumper. To access, pull the release handle located in the front electrical and service compartment. Although the bumper is heavy, sprung hinges permit one person operation.

When closing bumper compartment, make sure bumper is securely installed.

NOTE

Converted vehicles contain no spare wheel. Access to compartment is also obtained by pulling the release handle located in the front service compartment.



WARNING

This compartment has not been designed for storage. Never leave loose objects in this area since they may interfere with steering linkage mechanism. Make sure bumper is safely locked in place after closing the compartment.

10.1 PULLING OUT SPARE WHEEL

To pull out spare wheel, open reclining bumper according to the previous instructions

Untighten the pressure screw holding the tire in place. Lift the pressure screw arm and move to the side. Pull the spare wheel out of the compartment.

NOTE

The pressure screw arm must return to its initial position otherwise, the bumper cannot be latched in upper position.

NOTE

Store damaged wheel in spare tire compartment. Repair and balance the flat tire as soon as possible.

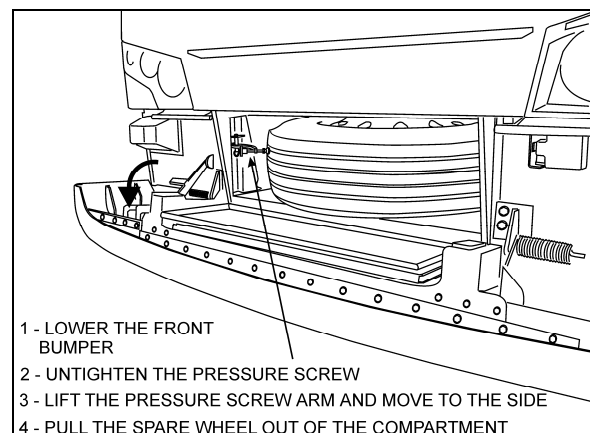

FIGURE 9: SPARE WHEEL AND TIRE 18415

NOTE

The jack and wheelnut wrench are stored at the ceiling of the forward baggage compartment, on the R.H. side..

The jack/tools kit contains a:

1. 30 ton hydraulic jack;
2. Wheel nut wrench and lever.
3. Triangular reflectors kit.

NOTE

Check the inflation pressure of the spare tire periodically to keep it ready for use. Inflate spare tire to the pressure of the tire, which has the highest pressure on the vehicle. When installing, deflate to correct pressure if necessary.

10.2 CHANGING A FLAT TIRE

In case of flat tire, refer to appropriate procedure under "Wheel Maintenance" heading in this section.

NOTE

For hydraulic jack placement, refer to Section 18 "Body", under heading "Vehicle Jacking Points".



DANGER

Place jack on stable and level ground; if necessary, place a board under the jack. Do not raise the vehicle until you are sure the jack is securely engaged.



WARNING

To prevent personal injury and/or equipment damage, use only the recommended jacking points. Passengers must not remain inside vehicle while wheel is being replaced.



CAUTION

Adjust tire pressure according to the appropriate cold tire inflation-pressure.

NOTE

Store damaged wheel in spare tire compartment. Repair and balance the flat tire as soon as possible.

10.3 SPARE WHEEL MAINTENANCE

Maintenance of the spare wheel and tire consists in ensuring that tire inflation pressure is the same as the tire on the coach that has the

highest inflation pressure (refer to "Specifications" in this section for the recommended tire inflation pressure). Inspect rim to ensure that there is no important corrosion. In addition, check if spare wheel covering is in good condition and check that spare tire is securely fastened in compartment.

11. TIRE MAINTENANCE

The most critical factor in tire maintenance is proper inflation (Fig. 10). No tire is impervious to loss of air pressure. To avoid the hazards of under inflation, always maintain tires at their recommended inflation pressure. Improper inflation decreases tire life.

An under inflated tire builds up heat that can cause sudden tire destruction, resulting in improper vehicle handling and possible loss of vehicle control. At least once a week, before driving (when tires are cold), check inflation pressure on all the tires, including the spare tire. This is especially important in cases when different drivers operate the vehicle.



WARNING

Failure to maintain correct tire inflation pressure may result in sudden tire destruction, improper vehicle handling, and will cause rapid and irregular tire wear. Inflation pressure should be checked weekly and always before long distance trips.

11.1 INFLATION PRESSURE

- Vehicles equipped with BERU TPMS

On vehicles equipped with the Beru Tire Pressure Monitoring System (TPMS), it is better to use the TPMS display as the primary reference to judge when tire pressure need adjustment.

The TPMS presents pressure readings of each tire as a +/- deviation from the wanted target.

If a tire reads within +/- 3 PSI no adjustment is needed.

If a tire reads -4 PSI and below, re-inflate by the marked amount.

If a tire reads +4 PSI and above, deflate by the marked amount.

Relying on the TPMS system is better than relying on a hand gage since the TPMS is temperature compensated and remain accurate no matter if the tires are cold or hot.

Section 13: WHEELS, HUBS & TIRES

Tires take up to 3 hours to get down to ambient temperature after a ride. A common mistake consist of checking pressure while the tires have not fully cooled down which leads into under-inflated tires. Relying on the TPMS eliminate this mistake.

Running tires at optimal pressure reduce tire wear, improve safety and fuel economy.

NOTE

It is more accurate to use the TPMS display to set the tire pressures than a pressure gauge.

The TPMS target pressures are factory set to equal the prevailing tire pressure at delivery time.

When tire pressures are increased to account for higher vehicle weight, the TPMS set point need to be increased accordingly.

- Vehicles not equipped with BERU TPMS

The condition and pressure of the tires can greatly affect both useful tire life and road safety.

At regular intervals, verify the tire pressures. Use an accurate tire pressure gauge when checking inflation pressures. Never exceed the maximum inflation pressure specified on each tire.

NOTE

Inflation pressure should be checked when tires are cold. Cold tire inflation pressure can be measured when a vehicle has not been driven for at least 3 hours or less than 1 mile (1.6 km). Driving, even for a short distance, causes tires to heat up and air pressure to increase. Check inflation pressure on all tires (including the spare tire) using an accurate tire gauge.

NOTE

The recommended tire inflation pressures are given in the applicable documents supplied with the vehicle. In addition, cold tire inflation pressures are listed on the Department of Transport's certification plate, affixed on the panel behind the driver's seat. For special tire selection, a "PRÉVOST COACH SPECIAL SPECIFICATION" chart is supplied with the vehicle and is affixed on the left wall near the driver's seat. Remember, tire inflation pressure must be adjusted according to vehicle loading - see table in "Coach Final Record"

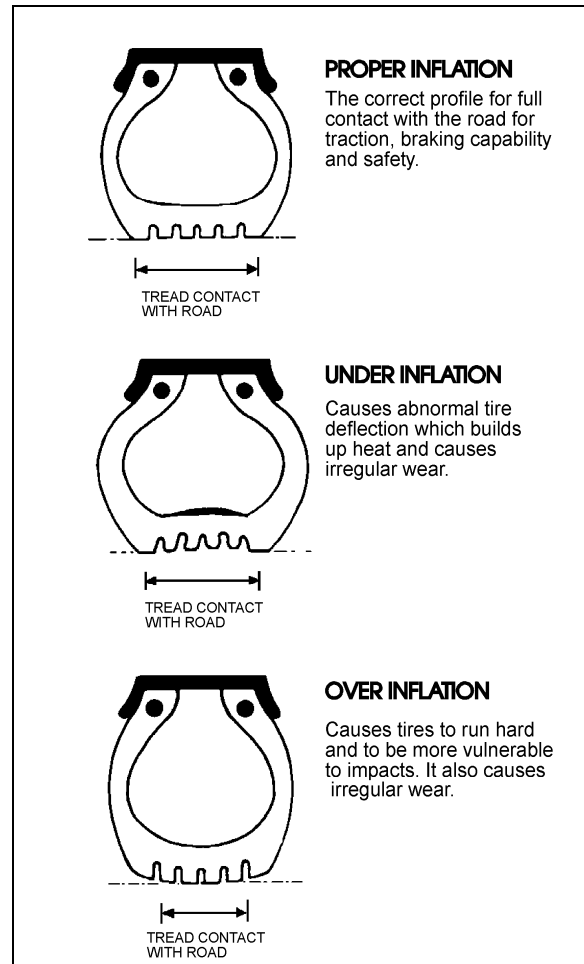

FIGURE 10: TIRE INFLATION

13009



CAUTION

Never bleed air from hot tires as tires will then be under inflated. Use an accurate tire gauge to check pressures (Do not kick tires as an inflation check. This is an unreliable method).



CAUTION

These tire pressures are established in accordance with the maximum allowable load on each axle. A lower pressure is recommended if the axle load is less than the above specifications. Weigh vehicle fully loaded and pressurize according to tire manufacturer's recommendations. For other tire and wheel specifications, see Prévost tire pressure tabulation in "Coach Final Record".

**WARNING**

Incorrect tire pressures cause increased tire wear and adversely affect road holding of the vehicle, which may lead to loss of vehicle control.

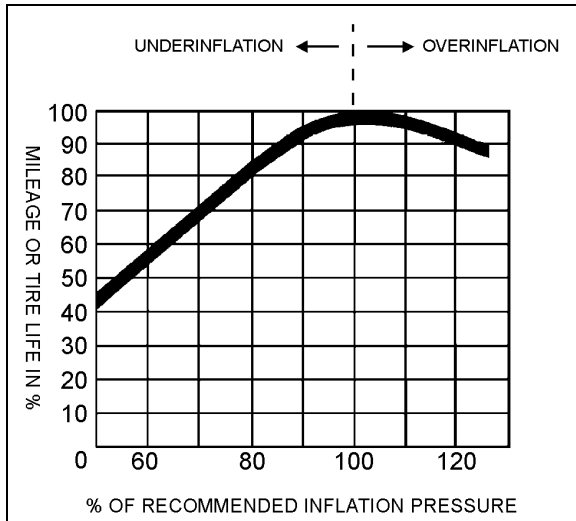

FIGURE 11: TIRE LIFE / INFLATION PRESSURE 13010

**WARNING**

Recommended tire inflation pressures and maximum allowable loads apply to speeds up to 65 mph (105 km/hr). Do not drive vehicle at a higher speed than 65 mph (105 km/h) or above the posted speed limit.

**WARNING**

All tires on the same axle should always be inflated to the same pressure. There should not be a difference in pressure between right and left tires on the same axle.

A 5-psi (35-kPa) underinflation in one front tire can not only reduce vehicle maneuverability, but will create steering hazards which can lead to an accident.

11.2 TIRE MATCHING

Unmatched tires on drive axle will cause tire wear and scuffing, as well as possible damage to the drive unit. Consequently, we recommend that tires be matched within 1/8" (3 mm) of the same rolling radius.

NOTE

It is recommended that all tires on coach be of the same type.

11.3 WHEEL BALANCING

Before balancing, wheels must be clean and free from all foreign matter. The tires should be in good condition and properly mounted. An unbalanced wheel can be due to a bent wheel or improper mounting. Before removing the wheel from the vehicle, check for swaying movement and if necessary, check the wheel lateral runout as outlined under heading "Wheel Straightness Check".

**WARNING**

When balancing wheel and tire assemblies, it is strongly recommended to closely follow instructions covering the operation of wheel balancer.

**CAUTION**

A maximum of 16-oz (450 g) of balancing weight is recommended. If more weight is necessary, check and correct the cause.

11.4 TIRE ROTATION

Radial tires should be rotated only when necessary. If the tires are wearing evenly, there is no need to rotate. If irregular wear becomes apparent or if the wear rate on the tires is perceptively different (from axle to axle), then tires should be rotated in such a manner as to alleviate the condition.

NOTE

There is no restriction on criss-cross rotation.

Section 13: WHEELS, HUBS & TIRES

12. SPECIFICATIONS

STEEL WHEELS (including inner drive axle)

Wheel size..... 9.0" X 22.5"
Wheel nut torque..... 450 - 500 lbf-ft (610 - 680 Nm)
Tire size..... 315/80 R 22.5 load range "L"

ALUMINUM WHEELS (except inner drive axle wheel on coaches)

Wheel size..... 9" X 22.5"
Wheel nut torque..... 450 - 500 lbf-ft (610 - 680 Nm)
Tire size..... 315/80 R 22.5 load range "L"

WHEELS ON VIP (Front & Tag axle)

Wheel size..... 10.5" X 22.5"
Wheel nut torque..... 450 - 500 lbf-ft (610 - 680 Nm)
Tire size..... 365/70 R 22.5

OPTIONAL WHEELS ON VIP (Drive axle)

Wheel size..... 14" X 22.5" hub mounted wheel
Wheel nut torque..... 450 - 500 lbf-ft (610 - 680 Nm)
Tire size..... 455/55 R 22.5

RECOMMENDED TIRE INFLATION PRESSURE AT MAXIMUM LOAD (cold)

NOTE

Vehicle is delivered with the specific inflation pressure certification plate according to the tire selection.

**WARNING**

Special tire selection may lower maximum allowable speed limit, even below posted speed limit. For maximum safety, check with tire manufacturer.

**CAUTION**

In the case of a converted vehicle, weigh fully loaded and pressurize according to tire manufacturer's recommendations.

**WARNING**

Recommended tire inflation pressures and maximum allowable loads apply to speeds up to 65 mph (105 km/hr). Do not drive vehicle at a higher speed than 65 mph (105 km/h) or above the posted speed limit.

ALUMINUM WHEEL CLEANING AND MAINTENANCE PRODUCTS

Aluminum Wheel Cleaner (22 Oz bottle)Prevost #683529
Aluminum Wheel Polish (16 Oz bottle)Prevost #683528
Aluminum Wheel Sealer (13 Oz bottle)Prevost #683527