

# **OPERATION & MAINTENANCE MANUAL FOR PREVOST H345 TRIAL SYSTEM**

**Manual Number 160339  
Revision 09SEPT04**

**TABLE OF CONTENTS**

Introduction	3
System Operation	3
System Block Diagram	4
Operational Sequence	
Fire	5
Component Descriptions	
Protection Panel	6
Optical Fire Detector	7
Linear Thermal Detector	8
End-of-Line Device	8
Manual Activation Switch	9
Cone Nozzle	9
Fire Extinguisher	10
Component Locations	11
Electrical Interconnections	12
System Reset	
Fire	13
Periodic Maintenance	
Pre-Trip	15
3000 Miles or Monthly	15
18000 Miles or Semi-Annually	16
6 Years	16
Trouble Shooting Guide	17
Replacement Parts List	19

## INTRODUCTION

This manual describes the operation and maintenance of the Kidde Dual Spectrum<sup>®</sup> Automatic Fire Detection and Suppression System (AFSS) as installed for trial purposes on one Prevost H345 bus (#1304) at Prevost Car Inc, Sainte-Claire, QC, Canada.

## SYSTEM OPERATION

When a fire is detected inside the engine compartment, the system sends a fire alarm signal to the Protection Panel located in the operator's area. The Protection Panel immediately turns on the fire "ALARM" lamp and sounds the audio alarm. After a 15-second time delay the engine is automatically shut down. The Fire Extinguisher is discharged simultaneously with engine shutdown. The Manual Activation Switch is used when immediate discharge of the Fire Extinguisher and engine shutdown are desired.

The Protection Panel continuously monitors system integrity and displays the information via the "SYSTEM OK" and fire "TROUBLE" indicators.

A system block diagram is shown in Figure 1.

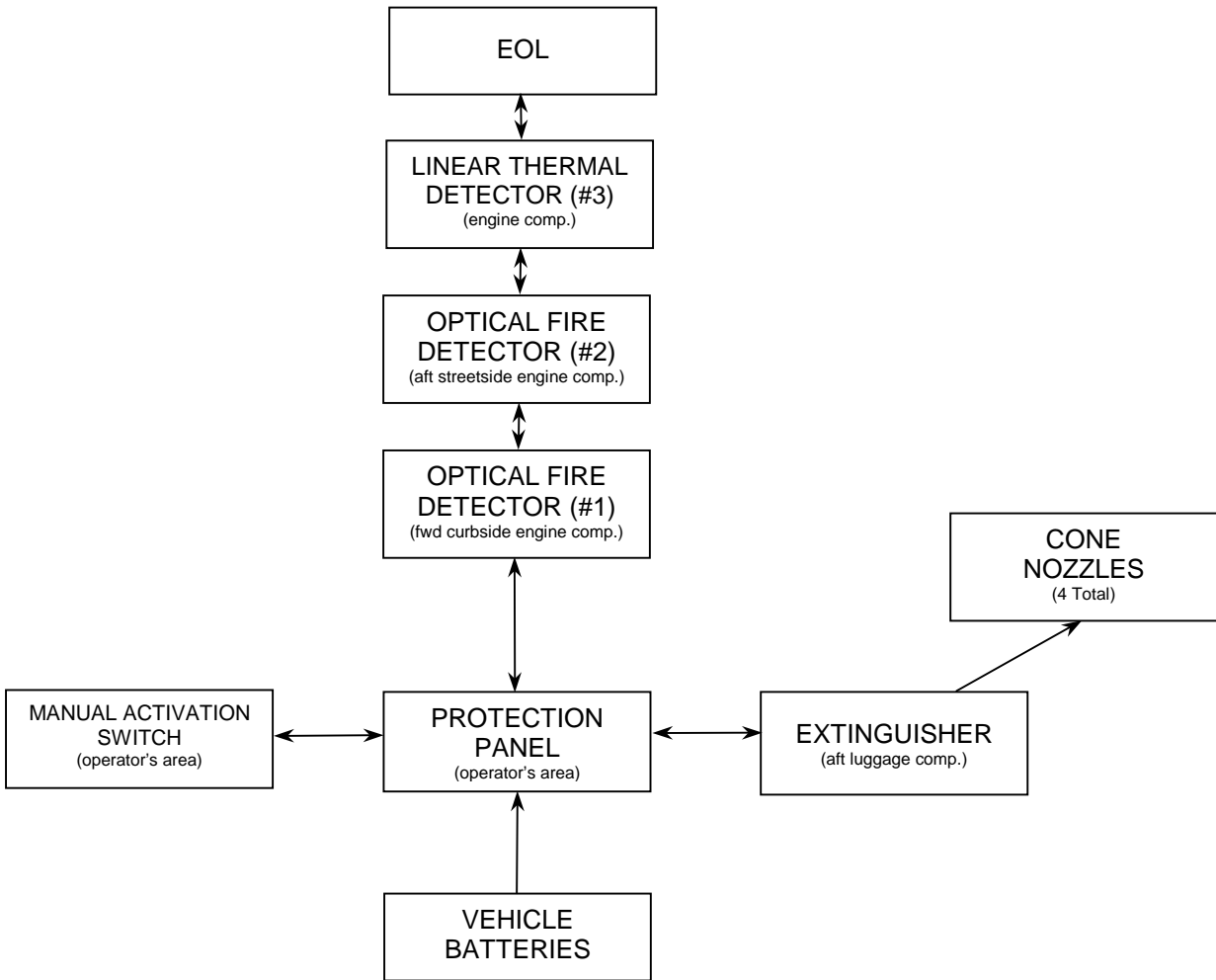

**FIGURE 1 - SYSTEM BLOCK DIAGRAM**

## OPERATIONAL SEQUENCE (FIRE)

### FIRE:

1. An Optical Fire Detector or Liner Thermal Detector detects a fire in the engine compartment and sends a signal to the Protection Panel in the operator's area.
2. The fire "ALARM" lamp on the Protection Panel will illuminate solid red and an audible alarm will sound.
3. The operator shall bring the vehicle to a safe stop.
4. The system automatically shuts down the vehicle engine and discharges the Extinguisher into the engine compartment 15 seconds after the fire alarm starts unless advanced or delayed by the operator.
  - If the operator presses the Manual Activation Switch, all delays will terminate and the engine shutdown and extinguisher discharge will occur immediately.
  - If the operator presses and releases the 'DELAY ENGINE STOP' switch once, the engine shutdown and extinguisher discharge will be delayed by an *additional* 15 seconds.

**WARNING**

**THE ENGINE WILL STOP 15 SECONDS AFTER THE FIRE ALARM STARTS. THE OPERATOR MUST BE PREPARED TO BRING THE VEHICLE TO A SAFE STOP AS SOON AS THE ALARM SOUNDS. STEERING MAY BECOME DIFFICULT AFTER ENGINE SHUTDOWN. IF MORE TIME IS REQUIRED, THE "DELAY ENGINE STOP" SWITCH MAY BE PRESSED AND RELEASED FOR AN ADDITIONAL 15 SECOND DELAY.**

**WARNING**

**THE EXTINGUISHER DISCHARGE MAY CAUSE AN OBSCURING CLOUD BEHIND AND NEAR THE VEHICLE**

5. The red Fire "ALARM" lamp and audible alarm will stay on. The yellow fire "TROUBLE" lamp will also be on indicating a discharged Extinguisher.
6. The system must be reset and the Fire Extinguisher removed and replaced in accordance with the 'SYSTEM RESET' portion of this manual.

## COMPONENT DESCRIPTIONS

### PROTECTION PANEL

The Protection Panel is located in the operator's area and displays the current system status. The Protection Panel contains "SYSTEM OK", fire "ALARM" and "TROUBLE" lamps, the audio alarm, the "TEST/RESET" switch, and the "ALARM SILENCE" switch.

The "SYSTEM OK" lamp indicates power is on to the system and that there are no trouble conditions present. The "TROUBLE" lamp blinks if there is a fault in the detection circuitry and illuminates solid if there is a fault in the extinguishing circuitry. When the "TROUBLE" lamp is on, the "SYSTEM OK" lamp will be off and the audible alarm will sound intermittently. The "SYSTEM OK" lamp will flash when the system is low on battery power. Depressing the "TEST/RESET" switch tests the Protection Panel's lamps and audio alarm. The "ALARM SILENCE" switch will disable the audio alarm.

When a fire detector automatically detects a fire, the fire "ALARM" lamp and audio alarm activate. When the Manual Activation Switch is activated, the fire "ALARM" lamp blinks and the audio alarm activates. The lamp will remain blinking until power is cycled to the system.

The engine shutdown output is a normally open contact (1 Amp maximum) which shorts to ground 15 seconds after fire and/or significant gas leak detection. The "DELAY ENGINE STOP" will be illuminated immediately following detection. Pressing the "DELAY ENGINE STOP" will delay engine shutdown (and extinguisher discharge with fire detection only) an extra 15 seconds. The additional delay will be indicated by a flashing "DELAY ENGINE STOP".

The Protection Panel also has other features which can be enabled via internal configuration switches.

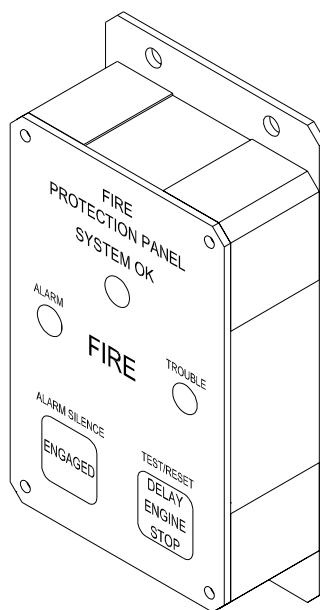

**FIGURE 2 - PROTECTION PANEL**

## **OPTICAL FIRE DETECTOR**

The Kidde Dual Spectrum® model PM-3M fire sensor operates by sensing two separate bands of infrared energy. A fire signal is generated when the sensors see a fire fueled by gasoline, diesel, CNG, LNG, LPG, methanol, oils, lubricants, and other types of hydrocarbons.

The fire sensor has a 100° solid cone field-of-view. It has a response time to explosive fires of one half of a second maximum. The PM-3M has a detection threshold of 42 inches for a one square foot pan fire fueled by diesel.

The fire sensor is immune to false alarms from sunlight, flashlights, lightning, vehicle headlights, incandescent lights (100W at 2 inches), and welding arcs (30 inches).

Each fire sensor has a green status light in the center of its front surface. The status light is illuminated when the fire sensor has electrical power. The status light will blink after the sensor has responded to a fire. The blinking will not stop with system reset, but is cleared when power has been cycled to the sensor. This feature can be used to help pinpoint the source of the fire.

The temperature operating range of the fire sensor is -40°F to 257°F (-40°C to 125°C). Input current is 5 mA quiescent.

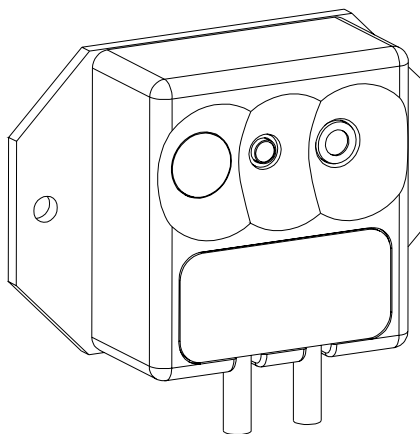

**FIGURE 3 – OPTICAL FIRE DETECTOR**

### **LINEAR THERMAL DETECTOR (LTD)**

The Linear Thermal Detector (LTD) is a twin conductor cable with temperature-sensitive insulation protected by an outer sheath. It operates by short-circuiting in a fire or overheat condition. The LTD provides economical detection in vehicle engine bays, fuel storage tanks and any other location where the threat of fire exists. The LTD is capable of detecting a fire at any point along its length and will react to a fire situation within 20 seconds. The cable is not resettable however. If the wire alarms to a fire, the wire must be replaced or the damaged section cut out and a new section added prior to returning the system to service. The added section can be ordered as 420413-x where x indicates the length in feet required. Interface connectors must be added to the original LTD. LTD's are shock and vibration resistant.



**FIGURE 4 – LINEAR THERMAL DETECTOR**

### **END-OF-LINE DEVICE**

The End-of-Line device is required for supervision of the fire detection circuits. It consists of a resistor installed into a connector and is environmentally sealed with potting compound. The End-of-Line device is installed on the last detector in each series of detectors.

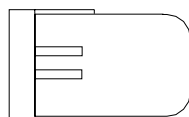
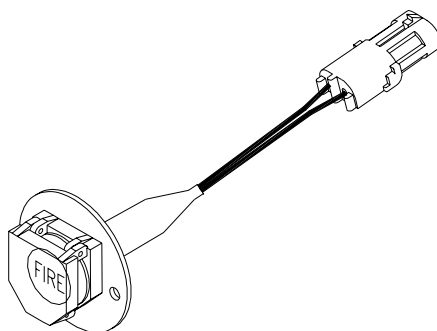

**FIGURE 5 – END-OF-LINE DEVICE**



## MANUAL ACTIVATION SWITCH

The Manual Activation Switch allows immediate system activation (extinguisher discharge and engine shutdown) by the vehicle operator at any time. Activation of the switch is accomplished by twisting and pulling the tamper seal (not shown) to remove, lifting the cover and pressing the red “FIRE” button for more than half a second. After the Manual Activation Switch has been activated, the Protection Panel will blink the fire “ALARM” indicator until power has been cycled to the system.



**FIGURE 6 – MANUAL ACTIVATION SWITCH (DEPICTED WITHOUT TAMPER SEAL)**

## CONE NOZZLE

The Cone Nozzle is constructed of plated steel and contains a 45° steel cone, causing the nozzle to disperse a cone shaped spray of dry chemical. The nozzle has a silicone rubber protective cap that is blown off by the dry chemical discharge.

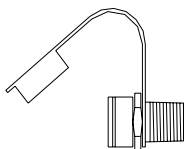

**FIGURE 7 – CONE NOZZLE**

## FIRE EXTINGUISHER

The Fire Extinguisher is an electrically operated, stored pressure type extinguisher that contains 22 pounds of BC rated 'Purple K' dry chemical extinguishing agent pressurized with nitrogen. A fast opening valve is mounted on a DOT certified cylinder. The Extinguisher is installed vertically in the bottle-mounting bracket.

### **CAUTION**

**THE EXTINGUISHER WILL NOT FUNCTION AS INTENDED IF ORIENTED INCORRECTLY**

### **WARNING**

**THE ANTI-RECOIL PLUG SHALL BE INSTALLED ON THE VALVE OUTLET PORT AT ALL TIMES EXCEPT WHEN THE EXTINGUISHER IS CONNECTED TO THE DISTRIBUTION PIPING OR WHILE THE EXTINGUISHER IS BEING FILLED.**

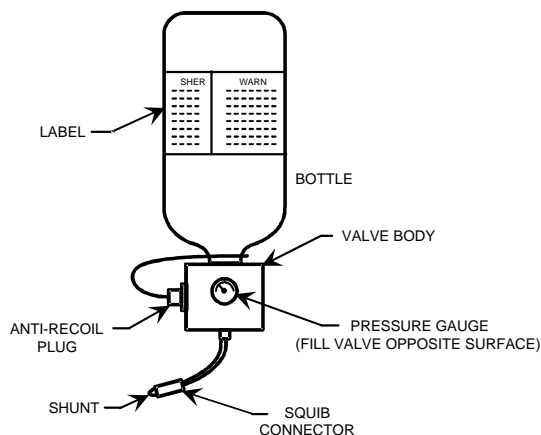







**FIGURE 8 – FIRE EXTINGUISHER**

## COMPONENT LOCATIONS

The major system components consist of a Protection Panel, 2 Optical Fire Detectors, 1 Linear Thermal Detector, 1 End-of-Line Device, a Manual Activation Switch, a Fire Extinguisher and 4 Cone Nozzles. See figure 9.

KEY:

-  PROTECTION PANEL
-  MANUAL DISCHARGE SWITCH
-  OPTICAL FIRE DETECTOR
-  LINEAR THERMAL DETECTOR
-  END-OF-LINE DEVICE
-  EXTINGUISHER
-  NOZZLE

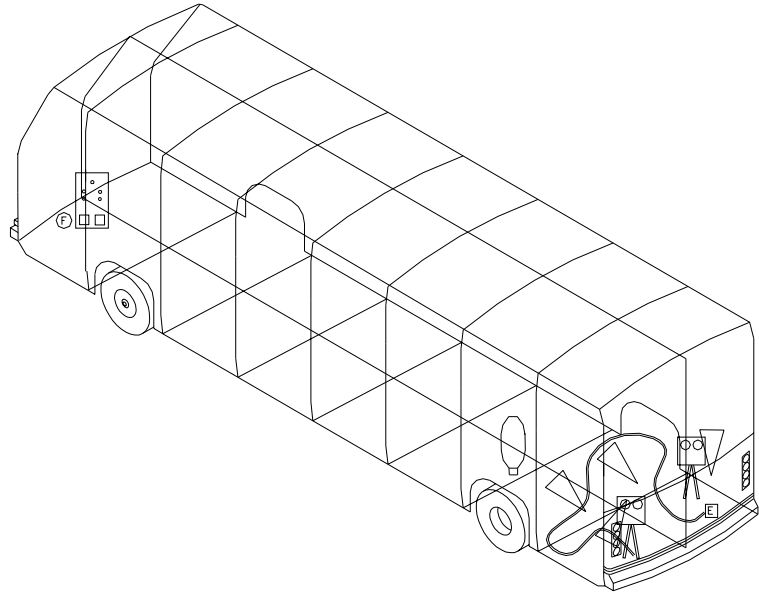

**FIGURE 9 – MAJOR SYSTEM COMPONENTS**

## ELECTRICAL INTERCONNECTIONS

The vehicle harness connects directly to the vehicle batteries, Protection Panel, Manual Activation Switch, Extinguisher, and first Optical Fire Detector. Additional Optical Fire Detectors and Linear Thermal Detector are connected to the preceding detector using interconnect harness. The vehicle harness also connects the Protection Panel's 'Engine Shutdown' output to the vehicle's multiplex system. See figure 10.

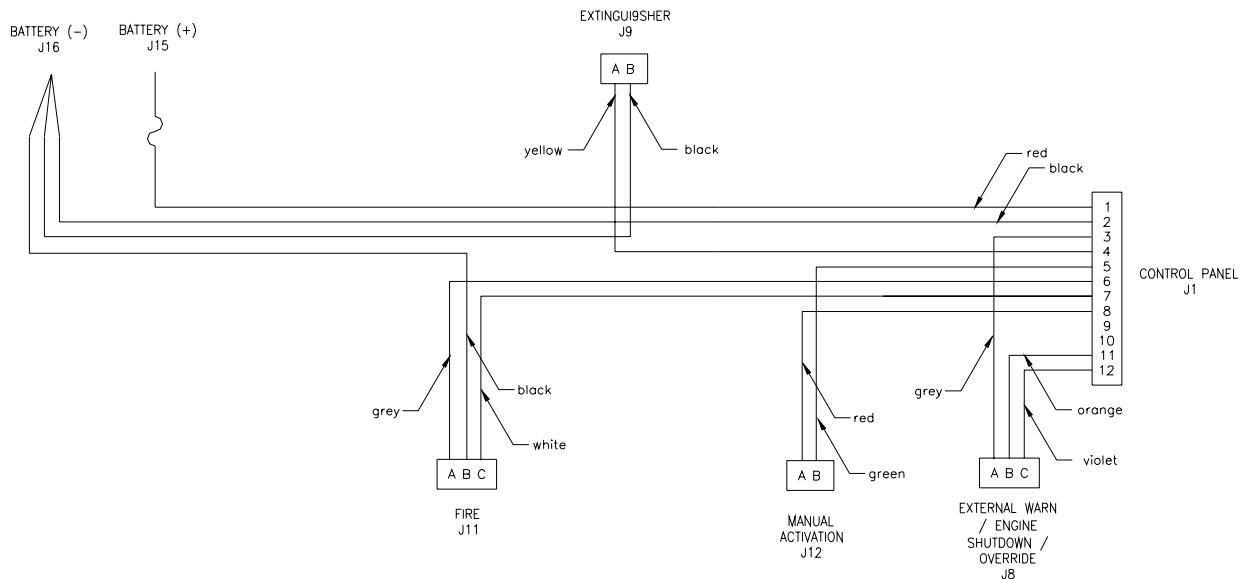

**FIGURE 10 - VEHICLE HARNESS**

## SYSTEM RESET

### FIRE:

After a fire in the engine compartment, the system is restored to operational status as follows:

1. Disconnect system power by removing system fuse located in battery compartment.
2. Repair and/or replace any damaged detection devices and/or electrical harnessing.
3. Remove the Fire Extinguisher:
  - a) Disconnect the electrical connector on the extinguisher valve from the vehicle harness.
  - b) Install a shorting plug to the electrical connector on the extinguisher valve.
  - c) Remove the distribution piping from the valve outlet port and install the anti-recoil plug.

**WARNING**

**THE ANTI-RECOIL PLUG SHALL BE INSTALLED ON THE VALVE OUTLET PORT AT ALL TIMES EXCEPT WHEN THE EXTINGUISHER IS CONNECTED TO THE DISTRIBUTION PIPING OR WHILE THE EXTINGUISHER IS BEING FILLED.**

- 
- 
- 
- d) Loosen the mounting clamps and remove the extinguisher.

**CAUTION**

**DO NOT ATTEMPT TO REBUILD THE EXTINGUISHER. HAVE THE FIRE EXTINGUISHER REBUILT BY A QUALIFIED FIRE PROTECTION EQUIPMENT COMPANY FAMILIAR WITH KIDDE DUAL SPECTRUM EQUIPMENT. REBUILD SHALL INCLUDE SQUIB, VALVE SEALS AND DRY CHEMICAL REPLACEMENT.**

- 
- 
- 
4. Remove the dry chemical nozzles from the distribution tubing for inspection and cleaning.
5. Blow out the distribution tubing with dry compressed air to insure the tubing is dry and free of debris and/or residual agent.
6. Reinstall the dry chemical nozzles wrench tight. NOTE: Do NOT use pipe dope or Teflon tape on the threads.
7. Replace the Fire Extinguisher:

- a) Inspect the new extinguisher; verify it is the correct part number to ensure it is the correct configuration for the application and verify the anti-recoil plug and the shorting plug are installed.
- b) Install the extinguisher in the mounting bracket and oriented per the instructions on the extinguisher nameplate. Tighten the mounting clamps. Do NOT connect the electrical connector at this time.

**CAUTION**

**THE EXTINGUISHER WILL NOT FUNCTION AS INTENDED IF ORIENTED INCORRECTLY**

- c) Remove the anti-recoil plug and immediately connect the distribution piping.
- d) Connect system power by replacing the system fuse located in the battery compartment and verify the red fire 'ALARM' lamp on the Protection Panel is NOT on. NOTE: The fire 'TROUBLE' lamp will be on because the electrical connector on the extinguisher valve is not connected.

**CAUTION**

**IF THE PROTECTION PANEL IS IN ALARM CONDITION, THE EXTINGUISHER MAY DISCHARGE IF IT IS CONNECTED TO THE SYSTEM. BE SURE THE RED FIRE 'ALARM' LAMP ON THE PROTECTION PANEL IS NOT ILLUMINATED BEFORE PROCEEDING FURTHER.**

- e) Remove the shorting plug from the electrical connector on the extinguisher valve.
  - f) Attach the vehicle harness to the electrical connector on the extinguisher valve.
7. Verify the green 'SYSTEM OK' lamp on the Protection Panel and green status lamp on each Optical Fire Detector is on solid.

## PERIODIC MAINTENANCE

### PRE-TRIP

- Verify the Protection Panel 'SYSTEM OK' lamp is on solid green

### EVERY 3000 MILES OR MONTHLY (whichever occurs first)

#### General

- Verify neither the protected equipment nor the hazard has changed
- Verify no obvious physical damage or condition exists that might prevent system operation

#### Protection Panel

- Verify all warning lamps and the audible alarm are operational by pressing the 'TEST/RESET' button

#### Manual Activation Switch

- Verify tamper seal is intact and access to switch is unobstructed

#### Fire Detectors

- Optical
  - Verify status lamp on the detector face is on solid green
  - Verify nothing is blocking the detector's field of view
  - Verify the windows on the face of the detector are free of excess contamination (dirt, oil, grease, etc) - if necessary, clean using water soaked non-abrasive towel
- Linear Thermal
  - Verify there is no obvious physical damage and that unit is free of excess contamination (dirt, oil, grease, etc) - if necessary, clean using water soaked non-abrasive towel
  - Verify mounting is secure and taught

#### Electrical Harness

- Verify electrical connectors and electrical wiring have no visible damage and all connectors are securely seated

#### Extinguisher & Distribution System

- Verify the extinguisher pressure gauge pointer is in the green arc at room temperature
- Verify distribution piping and nozzles are intact and unobstructed and that nozzle blow-off caps are in place

**EVERY 18000 MILES OR SEMI-ANNUALLY** (whichever occurs first)

- Perform a comprehensive fire system test using a Kidde Dual Spectrum System Test Set (Optical Test Kit P/N 420871-2)

**EVERY SIX YEARS**

- Have the fire extinguisher rebuilt by a qualified fire protection equipment company familiar with Kidde Dual Spectrum equipment. Rebuild shall include squib, valve seals and dry chemical replacement.
- At time of rebuild, if 12 or more years have passed since last hydrostatic test of the fire extinguisher cylinder; have the cylinder hydrostatically tested by a qualified fire protection equipment company familiar with Kidde Dual Spectrum equipment.



**TROUBLE SHOOTING GUIDE**

SYMPTOM	PROBABLE CAUSE	CORRECTIVE ACTION
All Protection Panel lamps off.	No power to system	Check connections to & voltage of vehicle batteries.  Check system fuse (15A).  Below 9 volts the system will not function
Protection Panel green "SYSTEM OK" lamp blinking.	Low battery voltage	Check connections to & voltage of vehicle batteries.  Below 22 volts the system will provide low voltage indication.
Protection Panel green "SYSTEM OK" lamp off, yellow fire "TROUBLE" lamp on, red fire "ALARM" lamp on solid and audible alarm on.	System automatically discharged	Correct the cause of the fire and reset the system as described in the system reset portion of this manual
Protection Panel green "SYSTEM OK" lamp off, yellow fire "TROUBLE" lamp on, red fire "ALARM" lamp on blinking and audible alarm on.	System manually discharged	Correct the cause of the fire and reset the system as described in the system reset portion of this manual
Protection Panel green "SYSTEM OK" lamp off, yellow fire "TROUBLE" lamp on solid and audible alarm beeping.	Component not connected or damaged harness in the extinguisher circuit	Check harness connections at extinguisher  Check electrical interconnections (Figure 10)
Protection Panel green "SYSTEM OK" lamp off, yellow fire "TROUBLE" lamp on blinking and audible alarm beeping.	Component not connected or damaged harness in the fire detection circuit	Check harness connections at fire sensors  Check connection at EOL  Check electrical interconnections (Figure 10)

<p>Bus will not start, Protection Panel red fire "ALARM" lamp on solid and audible alarm on</p>	<p>System not reset after fire</p>	<p>Correct the cause of the fire and reset the system as described in the system reset portion of this manual</p>
<p>Extinguisher pressure gauge reading is low</p>	<p>Extinguisher cold</p>	<p>Let extinguishers warm up to room temperature (about 70°F) and recheck the gauge. If the pointer is then within the green arc no corrective action is required</p>
	<p>Extinguisher leaking or discharged</p>	<p>Have the fire extinguisher serviced by a fire protection equipment company familiar with KDS equipment</p>

**REPLACEMENT PARTS LIST**

Protection Panel, P/N 413410-146

Manual Activation Switch Kit, P/N 421317

Manual Activation Switch Tamper Seal, P/N 421317-2

Optical Fire Detector, P/N 420010

Linear Thermal Detector (LTD), 20ft, P/N 420413-20

End-of-Line Device (EOL), P/N 420241

Vertical Fire Extinguisher, 22lb, BC, Gauge Right, P/N 408876-1232

Extinguisher Bracket Assembly, P/N 409475

Nozzle, Dry Chemical, P/N 408878-1

Wiring Harness, P/N 421410

Interconnect Harness, 13ft, P/N 420373-13

Optical Fire System Test Kit, P/N 420871-2