

SECTION 06: ELECTRICAL

CONTENTS

1	GENERAL DESCRIPTION	5
1.1	WIRING DIAGRAMS	5
1.1.1	Using Wiring Diagrams	5
1.1.2	Testing Circuits	6
1.2	WIRE SIZES AND COLORS	6
1.3	SPARE WIRES	6
1.4	CLEANING CONNECTORS	7
1.5	CIRCUIT BREAKERS	7
1.6	MULTIPLEX FUSES	7
1.7	RELAYS	8
1.8	PRECAUTIONS	8
2	H3 SERIES VEHICLES ELECTRICAL COMPARTMENTS	10
2.1	MAINTENANCE	10
2.2	MAIN POWER COMPARTMENT	10
2.2.1	Battery Charger Or In-Station Lighting Connector	12
2.3	FRONT ELECTRICAL AND SERVICE COMPARTMENT	12
2.4	ENGINE REAR START PANEL	13
2.5	A/C AND HEATING CONTROLS	13
2.6	PNEUMATIC ACCESSORY PANEL	13
3	BATTERIES	14
3.1	GROUP 31 ACID-LEAD BATTERY	14
3.2	GROUP 31 AGM BATTERIES	14
3.3	BATTERY DISCHARGE PROTECTION	15
3.4	MAIN BATTERY RELAYS	15
3.5	BATTERY REMOVAL AND INSTALLATION	15
3.6	BATTERY RATING	16
3.7	BATTERY TESTING	17
3.7.1	Visual Inspection	17
3.7.2	Removing Surface Charge	17
3.7.3	Load Test	17
3.7.4	Testing Battery Cables	18
3.8	BATTERY CHARGING	18
3.8.1	Battery Charging Guide	19
3.8.2	Emergency Jump Starting With Auxiliary (Booster) Battery	20
3.9	AGM BATTERY CHARGING PRECAUTIONS	21
3.10	BATTERY EQUALIZATION AND AGM BATTERIES	21
3.11	CLEANING AND INSPECTION	21
3.12	COMMON CAUSES OF BATTERY FAILURE	21
3.13	TROUBLESHOOTING	22
3.14	"BATTERY VOLTAGE WARNING" PICTOGRAM	22
3.14.1	Voltmeter Gauge Definitions	22
4	PRIME ENERGY MANAGEMENT SYSTEM	22
4.1	DESCRIPTION	22
4.2	COMPONENTS	23
4.3	DID DISPLAY	23
5	TROUBLESHOOTING AND TESTING THE MULTIPLEX VEHICLES	23
5.1	PROBING VOLTAGE ON THE MULTIPLEX CIRCUITS	23
5.2	CAN NETWORK	23
5.2.1	Spare Can	24
5.3	ELECTRICAL SYSTEM DIAGNOSTIC	24

Section 06: ELECTRICAL

5.4	MULTIPLEX INPUT TEST MODE	24
5.5	MOTOR TEST SEQUENCE	26
5.5.1	Test Sequence – Coaches only	26
5.5.2	Test Sequence – VIP With Central HVAC System	27
5.5.3	Test Sequence – VIP With Small HVAC System	27
5.6	FORCED ACTIVATION OF THE RADIATOR FAN CLUTCH	28
5.7	CAN NETWORK LAYOUT AND TROUBLESHOOTING	28
5.8	ROADSIDE TROUBLESHOOTING	33
5.9	ESSENTIAL FUNCTIONS TO OPERATE THE VEHICLE	37
5.9.1	Available Functions	38
5.10	LOWER PRIORITY MODULES FOR BREAKDOWN SERVICE	38
5.11	MULTIPLEX MODULES	38
5.11.1	MCM	38
5.11.2	I/O-A	38
5.11.3	I/O-B	38
5.12	MULTIPLEX MODULES REPLACEMENT	38
5.12.1	Replacing I/O-A Or I/O-B Modules And Initiating Autoprogramming	38
5.12.2	Replacing The MCM Module	39
6	ALTERNATORS	39
6.1	ALTERNATOR BRUSH REPLACEMENT	40
6.2	IDENTIFYING THE DEFECTIVE ALTERNATOR	41
6.3	ALTERNATOR DRIVE BELT	41
6.4	ADJUSTMENT	41
7	BATTERY EQUALIZER	42
8	STARTER	42
9	ENGINE BLOCK HEATER	42
9.1	MAINTENANCE	42
10	EXTERIOR LIGHTING	42
10.1	HEADLIGHTS	42
10.1.1	Headlight Beam Toggle Switch	42
10.1.2	Maintenance	43
10.1.3	Replacing headlight bulbs	43
10.1.4	Replacing Front Turn Signal LED module	43
10.1.5	Optional Xenon Headlamp (Low Beam)	44
10.1.6	Aiming headlights	44
10.2	STOP, TAIL, DIRECTIONAL, BACK-UP, AND HAZARD WARNING LIGHTS	45
10.2.1	Lamp Removal And Replacement	45
10.2.2	High-Mounted Stop Light Removal And Replacement	45
10.3	LICENCE PLATE LIGHT	46
10.4	CLEARANCE, IDENTIFICATION AND MARKER LIGHTS	46
10.4.1	Marker Light Removal And Replacement	46
10.4.2	Clearance And Identification Light Removal And Replacement	46
10.5	DOCKING AND CORNERING LIGHTS	47
10.5.1	Lamp Removal And Replacement	47
10.6	FOG LIGHTS	47
10.6.1	Bulb Removal And Replacement	47
11	INTERIOR LIGHTING EQUIPEMENT	48
11.1	CONTROL PANEL LIGHTING	48
11.1.1	Switch Lighting	48
11.1.2	Telltale Light Replacement	48
11.1.3	Gauge Light Bulb Replacement	48

11.2	STEPWELL LIGHTS	48
11.2.1	Coach Entrance.....	48
11.2.2	VIP Entrance	49
11.2.3	Bulb Removal And Replacement	49
11.3	LAVATORY NIGHT-LIGHT	49
11.3.1	Bulb Removal And Replacement	49
11.4	DRIVER'S AREA LIGHTS.....	49
11.4.1	Bulb Removal And Replacement	49
11.5	PASSENGER SECTION LIGHTING	49
11.5.1	Fluorescent Tube Replacement.....	49
11.5.2	Removal And Replacement Of In-Station Fluorescent Tubes	50
11.5.3	Removal And Replacement Of Reading Lamp Bulb.....	50
11.6	ENGINE COMPARTMENT LIGHTING	50
11.7	LAVATORY LIGHT	50
12	LIGHT BULB DATA	51
13	SPECIFICATIONS	52

ILLUSTRATIONS

FIGURE 1:	WIRE NUMBER	6
FIGURE 2:	MAIN BREAKERS	7
FIGURE 3:	MULTIPLEX MODULE CONNECTORS	8
FIGURE 4:	ELECTRICAL COMPARTMENTS.....	10
FIGURE 5:	MAIN POWER COMPARTMENT (PARTIAL VIEW).....	11
FIGURE 6 :	MAIN POWER COMPARTMENT.....	11
FIGURE 7:	FRONT ELECTRICAL AND SERVICE COMPARTMENT	12
FIGURE 8:	ENGINE REAR START PANEL	13
FIGURE 9:	HVAC PANEL IN EVAPORATOR COMPARTMENT	13
FIGURE 10 :	PNEUMATIC ACCESSORY PANEL.....	13
FIGURE 11:	BATTERIES.....	14
FIGURE 12 :	BATTERY CONNECTIONS (STANDARD ACID-LEAD GROUP 31).....	16
FIGURE 13:	AGM BATTERY CONNECTIONS WITH PRIME	16
FIGURE 14:	LOAD TEST	17
FIGURE 15:	ALLIGATOR CLAMPS AND BATTERY	19
FIGURE 16:	BOOSTER BLOCK	20
FIGURE 17:	PRIME DID DISPLAY	23
FIGURE 18:	BATTERY STATE OF CHARGE	23
FIGURE 19:	BATTERY ARRANGEMENT WITH PRIME	23
FIGURE 20:	IO-B MODULE REMOVAL.....	38
FIGURE 21:	ALTERNATORS DRIVE BELT	39
FIGURE 22:	ALTERNATORS AND ACCESSORIES MOUNTING TORQUES (H3 COACH SHOWN).....	40
FIGURE 23:	ALTERNATOR MOUNTING, TIGHTENING SEQUENCE – CENTRAL A/C SYSTEM.....	40
FIGURE 24:	ALTERNATOR MOUNTING, TIGHTENING SEQUENCE – SMALL A/C SYSTEM.....	40
FIGURE 25:	BOSCH HD10 BRUSH HOLDER MOUNTING SCREWS.....	40
FIGURE 26:	TWIN BOSCH HD10 CONNECTIONS	41
FIGURE 27:	ENGINE BLOCK HEATER PLUG LOCATION	42
FIGURE 28:	HEADLIGHT ASSEMBLY	42
FIGURE 29:	ROCKING THE HEADLIGHT ASSEMBLY	43
FIGURE 30:	HEADLIGHT ASSEMBLY REAR VIEW	43
FIGURE 31:	HEADLIGHT ASSEMBLY	44
FIGURE 32:	VERTICAL AIMING.....	45
FIGURE 33:	VARIOUS LIGHTS LOCATION	46
FIGURE 34:	FOG LIGHT MOUNTING BOLT	47
FIGURE 35:	FOG LIGHT EXPLODED VIEW.....	47
FIGURE 36:	SWITCH	48

Section 06: ELECTRICAL

FIGURE 37: COACH ENTRANCE STEPWELL 48
FIGURE 38: VIP ENTRANCE STEPWELL 49
FIGURE 39: PARCEL RACK 50
FIGURE 40: ENGINE COMPARTMENT LED MODULE..... 50

1 GENERAL DESCRIPTION

This vehicle uses a dual voltage system to obtain two different voltages (12-volt and 24-volt) for various electrical controls and accessories. The main power source incorporates four batteries connected in parallel-series. All batteries are kept uniformly charged by means of a 100 amp battery equalizer (standard), giving a maximum possible output supply of 100 amps on the 12-volt system. Both the 12-volt and 24-volt systems are controlled through individual main battery relays. Two 28-volt self-regulated alternators are belt driven from the engine, and can be reached through the engine compartment door.

Vehicles equipped with optional PRIME energy management system are equipped slightly differently and feature AGM batteries and a Vanner Vann-Bus 80 Series battery equalizer.

1.1 WIRING DIAGRAMS

A master wiring diagram of the electric circuits, covering standard and optional accessories and systems, is located in the technical publications box. Usually, a separate wiring diagram page is provided for each major function or system. In some cases, more than one circuit may appear on one wiring diagram page; when this occurs, each circuit covered in this page is listed in the wiring diagram index. Moreover, a circuit may appear on several pages; in such case, the number(s) at the extremity of the diagram title will indicate the sheet reference number. Refer to the "*Wiring Diagram Index*" to ensure that the correct diagram is being used to trace the circuit in question. In addition to the major functions page reference, the wiring diagram index contains the following information pages.

- The Multiplexed Device Index,
- The Arrangement-Harness drawing showing the harnesses arrangement and harness number on the vehicle,
- Glossary,
- Circuit number listing,
- Circuit breaker code,
- Connector code,
- Diode number code,
- Resistor number code,

- Fuse code.

1.1.1 Using Wiring Diagrams

Three methods are used to "*work*" with electric wiring diagrams.

Situation: You have identified the defective part (breaker, diode, relay, etc.), and you wish to locate its corresponding circuit.

Problem: Circuit breaker CB12 is released (open circuit) and you don't know which circuit is affected.

- a) Refer to wiring diagram index, and look for "*Circuit breaker code*", pages **F**.
- b) At item CB12, you will find the location, the Prevost number, the breaker function, the breaker ampere rating and the page on which to find the corresponding diagram.
- c) Refer to page 3.1.
- d) When you have located CB12, follow the wiring up to the end and find the diagram page number and function on which the circuit continues.

Situation: You have a problem with a specific system and you want to find the corresponding diagram.

Problem: The last three (3) speakers on the R.H. side of vehicle are inoperative and you must trace the electric circuit.

- a) Refer to wiring diagram index and look for "*Sound system*".
- b) You will find on page 35.1 & 35.2 the components as well as the electric wiring, thus providing you with a complete understanding of this circuit.

Situation: Using the Driver Information Display (DID), you check on arrival if there are active errors in the vehicle electrical system. With the DIAGNOSTICS menu, highlight **FAULT DIAGNOSTICS**, highlight **ELECTRICAL SYSTEM** to request a diagnostic of the electrical system and then press the enter key. If applicable, the DID shows the fault messages or fault codes recorded. When more than one fault is recorded, an arrow pointing down appears on the right of the display. Use the down button to see all the fault messages.

Problem: MCD displays the fault "Elec. Horn SW61 SW62; shorted to ground" as being active.

Section 06: ELECTRICAL

- Refer to wiring diagram index, and look for "*Multiplexed Device Index*", pages B1-B8.
- In first column DEVICE ID, look for device SW61, SW62.
- At device SW61, SW62, find the fault message, the minimum condition to activate, other inputs involved in logic, the multiplex module related to switch 61 and switch 62, the connector and pin number on the module and the page on which to find the corresponding diagram.
- Once the problem corrected, the MCD still shows the fault as being active. You have to leave the FAULT DIAGNOSTICS menu, wait approximately 20 to 30 seconds and then return to FAULT DIAGNOSTICS to request a new diagnostic of the ELECTRICAL SYSTEM. The DID should display the fault as being inactive.

1.1.2 Testing Circuits

A careful study of the wiring diagrams should be made to determine the source and flow of current through each circuit. When a circuit is thoroughly understood, a point-to-point check can be made with the aid of the applicable wiring diagrams. Any circuit can be tested for continuity or short circuits with a multimeter or a suitable voltmeter.

All electrical connections must always be kept clean and adequately tight. Loose or corroded connections can result in discharged batteries, difficult starting, dim lights and improper functioning of other electric circuits. Inspect all wiring connections at regular intervals. Make sure knurled nuts on all amphenol-type plugs are securely tightened. Knurled nuts on the plastic amphenol-type connectors will click into a detent when properly tightened. Line connectors, who have the side locking tabs, must have the locks latched in place to ensure a proper electrical connection.

1.2 WIRE SIZES AND COLORS

Each wire in the electrical system has a specific size as designated on the wiring diagram. When replacing a wire, the correct size must be used. Never replace a wire with one of a smaller size. The vehicle electrical system is provided with different voltages. The insulation on each wire is distinctly colored in order to determine visually the wiring voltage and to assist in making connectors. The wires are color coded as follows:

Yellow	Multiplex modules communication CAN-H (twisted with green)
Green	Multiplex modules communication CAN-L (twisted with yellow)
Orange	Connected to multiplex outputs
White	Connected to multiplex inputs
Red	24-volt system
Yellow	12-volt system
Black	grounded wire
Black	110 V ac system (live)
White	110 V ac system (neutral)
Green	110 V ac system (ground)
Orange	speakers (+)
Brown	speakers (-)
Grey	spare wire

NOTE

Wires are identified at each 2-4 inch (5-10 cm) intervals by a printed number.

Each wire on a diagram is patterned to assist in tracing and testing circuits. The wire number identifies the voltage rating, the wire identification number and the basic wire gauge as illustrated in Figure 1.

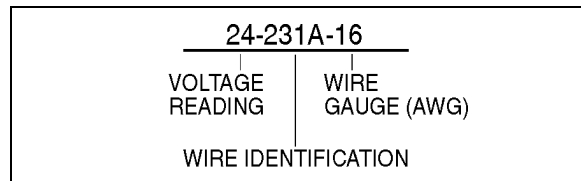

FIGURE 1: WIRE NUMBER

06048

1.3 SPARE WIRES

When the vehicle leaves the factory, and even in the case of a fully-equipped vehicle, an important number of unconnected spare wires are routed between the junction boxes to serve as replacement wires if regular wires are damaged. Refer to page 8.1 "*Spare wires*" and page E "*Circuit number listing*" to determine the number and location of these wires.



CAUTION

Wire size is calibrated according to the breaker or fuse that protects it. When using a spare wire to replace a damaged wire, assure that the spare wire size is equal or larger than the wire being replaced. Using a wire too small for the breaker or fuse amperage might cause overheating of the wire.

NOTE

Spare wires are identified by the letters "SP" and by the wire identification number.

1.4 CLEANING CONNECTORS

When connector pin and socket terminals become dirty, clean with a good quality solvent containing HFC 134A refrigerant as its active ingredient. HFC 134A has two qualities that recommend it. First, it does not conduct electricity and therefore, will not cause shorting between connector pins and sockets. Second, it evaporates quickly, eliminating the possibility of condensation within the connectors.

Always shake out or gently blow out any excess HFC 134A before assembling a connector to its mating connector or hardware. HFC 134A trapped in the connector can affect the connector seal.



DANGER

HFC 134A is toxic. HFC 134A bases compounds should always be used in a well-ventilated area, never in a confined space. Use outdoor whenever possible.

1.5 CIRCUIT BREAKERS

Most electric circuits are protected by manually switchable circuit breakers. The main circuit breakers, as well as those protecting the A/C system, are located in the main power compartment, on R.H. side of the vehicle (Fig. 2).

CIRCUIT BREAKERS (VIP)			
CB1	Front distribution	24 VI	90 amps
CB2	Front distribution	12 VD	90 amps
CB3	HVAC - evaporator	24 VI	90 amps
CB4	Rear distribution	12 VD	70 amps
CB5	Rear distribution	24 VI	150 amps
CB6	Rear Distribution	24 VD	70 amps
CB7	HVAC - condenser	24 VI	70 amps
CB8	Rear distribution	12 VI	40 amps
CB9	Slide-out	24VI	40 amps
CB10	Front distribution	12 VI	70 amps
CB60	Luggage door lock - VECR		20 amps
CB61	Luggage door lock - VECR		20 amps
CB62	Lower wiper - VECF		20 amps

This type of circuit breaker opens the circuit without disconnecting any wire. Push the red button on breaker to open the circuit, repair defective circuit, and afterwards lift the black tab of breaker to its original position to close the circuit.

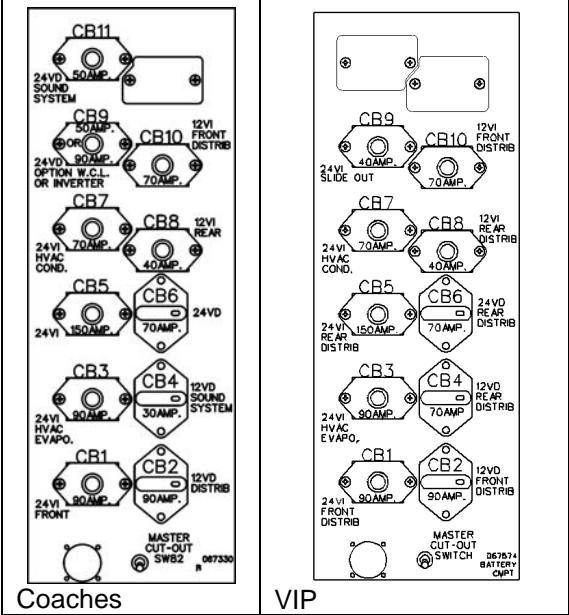

FIGURE 2: MAIN BREAKERS

CIRCUIT BREAKERS (coaches)			
CB1	Front distribution	24 VI	90 amps
CB2	Distribution	12 VD	90 amps
CB3	HVAC - evaporator	24 VI	90 amps
CB4	Sound system	12 VD	30 amps
CB5	Rear distribution	24 VI	150 amps
CB6	Distribution	24 VD	70 amps
CB7	HVAC - condenser	24 VI	70 amps
CB8	Rear distribution	12 VI	40 amps
CB9	WCL or other options	24VD	50 amps
CB10	Front distribution	12 VI	70 amps
CB11	Sound system	24 VD	50 amps
CB13	Galley		50 amps
CB14	Galley		90 amps
CB82	Wipers		20 amps
CBOP1	Driver seat		40 amps
CBOP1	Driver seat		40 amps

VD= volts direct. The electrical components connected to these circuit breakers are direct-connected to the battery.

VI= volts indirect. Electrical power is supplied via master relay R1 which engages when ignition key is in the ON or ACC position and battery master switch is set to ON.

1.6 MULTIPLEX FUSES

The multiplex outputs are protected in current by an internal "soft-fuse". Each output has programmed specific maximum amperage. When an output is shorted, the current gets above the limit and the soft-fuse intervenes to turn the output OFF. The output stays OFF until the "soft-fuse" is reset.

Section 06: ELECTRICAL

Turn the ignition key to the OFF position and turn to the ON position again. This resets all "soft-fuses".

There is also hardware fuses used to protect the incoming power to the multiplex modules. These fuses are located inside the VECF (Vehicle Electrical Center Front) and VECR (Vehicle Electrical Center Rear).

1.7 RELAYS

Relays are used to automatically energize or de-energize a circuit from a remote location. The relay draws a very low current to energize its coil. Once the coil is energized, it develops a magnetic field that pulls a switch arm closed or open, to either energize or de-energize a given component. As the control current required for the coil is very low, the relay allows a remote station to control a high energy circuit without running great lengths of costly high capacity cable, and also eliminates the need for high amperage switches and heavy connectors.

NOTE

Each relay is identified with "12 V" or "24 V" printed on its casing in order to identify the coil operating voltage.



CAUTION

The Multiplex vehicle uses a VF4 relay designed especially for Volvo that has different internal characteristics than the current VF4 relay. It is important to use only the new part marked Volvo as a replacement in Multiplex vehicles. Regular relays have an inadequate lifespan for Multiplex vehicles.

1.8 PRECAUTIONS



DANGER

Prior to working on a system inside vehicle, make sure to cut electrical power and air supply. A component could be supplied with electricity even if the ignition switch is set to the OFF position and/or a component could be pressurized even if air tanks are emptied. Always refer to the appropriate wiring and pneumatic diagrams prior to working on electrical and/or pneumatic systems.

NOTE

When the ignition switch is set to the OFF position, the electrical components are not energized except for the MCM, ECM (engine Control Module), transmission ECU, instrument cluster module, the battery equalizer, the preheater system, the wheelchair lift system and some Multiplex modules which are energized during 15 minutes after the ignition has been set to the OFF position. Prior to working on one of these electrical components, set the battery master switch in the main power compartment to the OFF position. If the vehicle will not be operated for a long period (more than 2 weeks), it is recommended, in order to prevent the batteries from discharging, to trip the main circuit breakers located in the main power compartment to stop the small current drawn by the radio preset station memory, the MCM memory and the instrument cluster clock. Note that the radio station presets will be erased, same thing for the diagnostic codes history and the instrument cluster clock will have to be reset.



CAUTION

Prior to arc welding on the vehicle, refer to "Multiplex Modules Disconnection Procedure Prior To Welding" in section 00 GENERAL of this manual to avoid serious damage to the vehicle components.

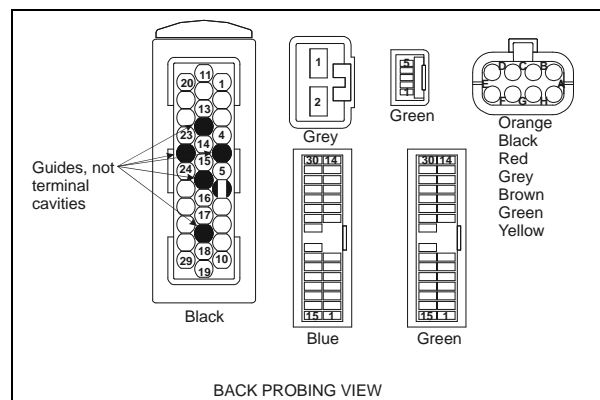
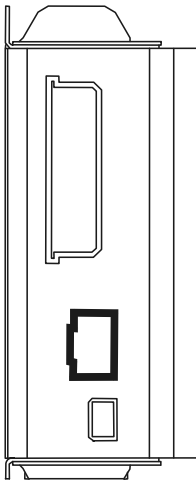
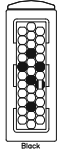
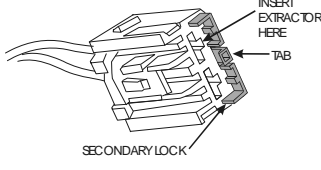
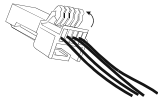
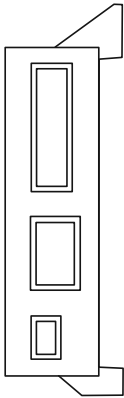
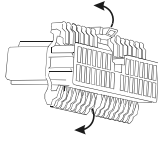
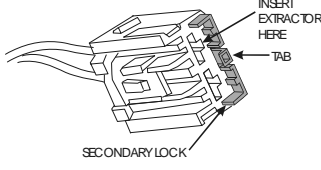

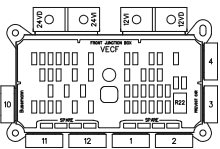
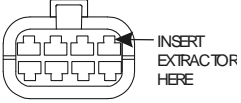

FIGURE 3: MULTIPLEX MODULE CONNECTORS PIN-OUT

Multiplex modules	Connector type	Terminal removal
 <p>IO-B 06625</p>	 <p>Block AMP 06628</p>	<p>EXTRACTOR/TOOL: Prevost #683594</p> <p>Insert the extractor on the front of the connector. Remove the terminal by disengaging the flexible lock tabs on the terminal. Gently remove the terminal from the connector by pulling on the wire.</p>
	 <p>INSERT EXTRACTOR HERE TAB SECONDARY LOCK grey 06629 YAZAKI</p>	<p>EXTRACTOR/TOOL: Packard #12094430</p> <p>Using a small flat blade screwdriver, open the hinged secondary lock. Insert the extractor on the front of the connector, over the terminal cavity. Remove the terminal by disengaging the flexible lock tab on the terminal. Gently remove the terminal from the connector by pulling on the wire.</p>
	 <p>green 06630 JAE</p>	<p>EXTRACTOR/TOOL: Prevost #683766</p> <p>Using a small flat blade screwdriver, open the hinged secondary lock. Insert the extractor on the front of the connector, over the terminal cavity. Remove the terminal by disengaging the flexible lock tab on the terminal. Gently remove the terminal from the connector by pulling on the wire.</p>
 <p>IO-A 06626</p>	 <p>green, blue JAE 06631</p>	<p>EXTRACTOR/TOOL: Prevost #683766</p> <p>Using a small flat blade screwdriver, open both hinged secondary locks. Insert the extractor on the front of the connector, over the terminal cavity. Remove the terminal by disengaging the flexible lock tab on the terminal. Gently remove the terminal from the connector by pulling on the wire.</p>
	 <p>INSERT EXTRACTOR HERE TAB SECONDARY LOCK grey 06629 YAZAKI</p>	<p>EXTRACTOR/TOOL: Packard #12094430</p> <p>Using a small flat blade screwdriver, open the hinged secondary lock. Insert the extractor on the front of the connector, over the terminal cavity. Remove the terminal by disengaging the flexible lock tab on the terminal. Gently remove the terminal from the connector by pulling on the wire.</p>
	 <p>green 06630 JAE</p>	<p>EXTRACTOR/TOOL: Prevost #683766</p> <p>Using a small flat blade screwdriver, open the hinged secondary lock. Insert the extractor on the front of the connector, over the terminal cavity. Remove the terminal by disengaging the flexible lock tab on the terminal. Gently remove the terminal from the connector by pulling on the wire.</p>
 <p>VECF 06627</p>	 <p>INSERT EXTRACTOR HERE Orange Black Red Grey Brown Green Yellow BUSSMANN 06632</p>	<p>EXTRACTOR/TOOL: Prevost #682256 (Packard 12094429)</p> <p>Remove the terminal by disengaging the flexible lock tab on the terminal. Gently remove the terminal from the connector by pulling on the wire.</p>

2 H3 SERIES VEHICLES ELECTRICAL COMPARTMENTS

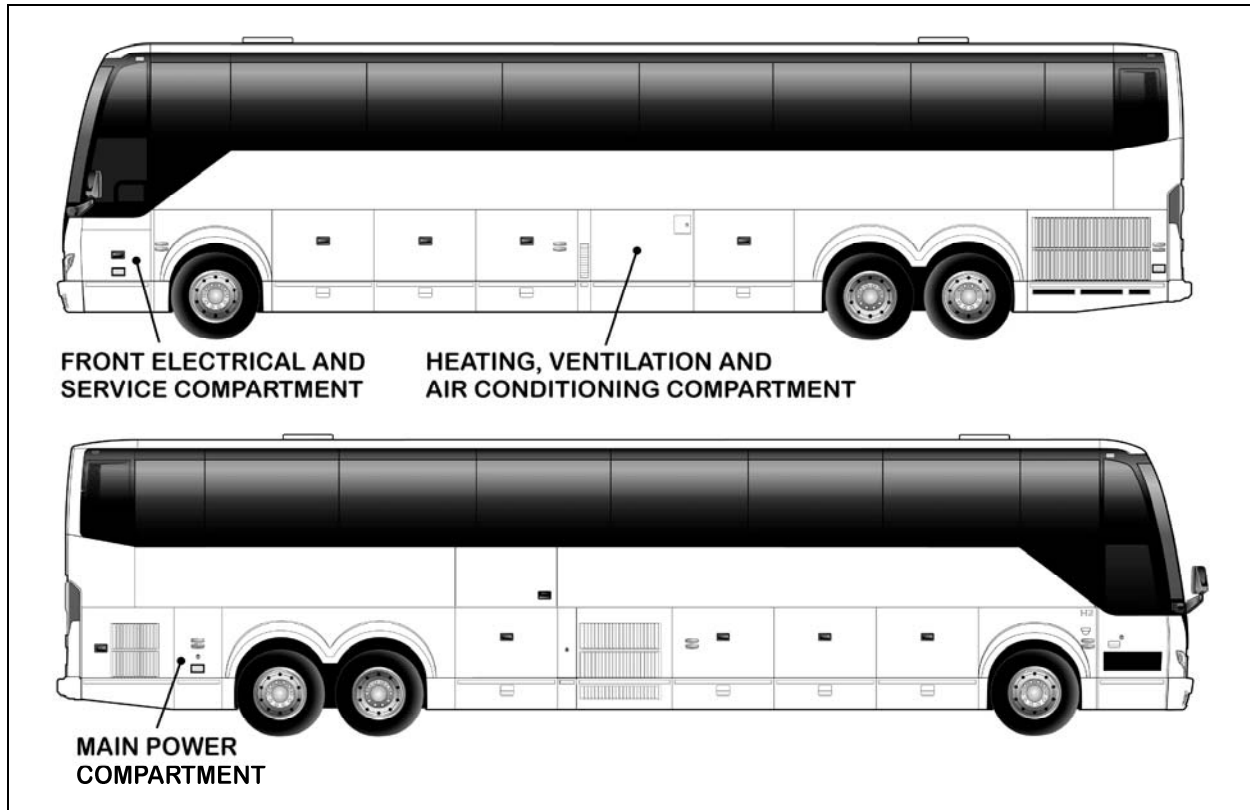



FIGURE 4: ELECTRICAL COMPARTMENTS

2.1 MAINTENANCE

A corrosion inhibitor has been sprayed on certain electrical components in order to protect them from corrosion. Refer to procedure SAV00002E at the end of this section for recommended products and where they are used.



DANGER

Use sprayed sealer in a well ventilated area. Do not smoke. Avoid prolonged contact with skin and breathing of spray mist.



CAUTION

Never put grease or other product on the multiplex modules connector terminals.

2.2 MAIN POWER COMPARTMENT

The main power compartment is located on rear R.H. side of vehicle behind the rear wheelhousing. This compartment contains the following components (fig. 5 & 6):

- Four 12-volt batteries;
- Main circuit breakers for 12-volt and 24-volt electrical system;
- Voltage regulator (if applicable);
- Battery equalizer;
- Battery Charger (optional);
- Battery master relay (R1) & battery master switch;
- TCM (Transmission Control Module);
- Secondary circuit breakers;
- Relays;
- Rear fuse box known as VECR (Vehicle Electrical Center Rear);
- Multiplex modules: I/O-A, I/O-B;

- OBD13 connector C464A (On-Board Diagnostic);
- Electronic ground stud.

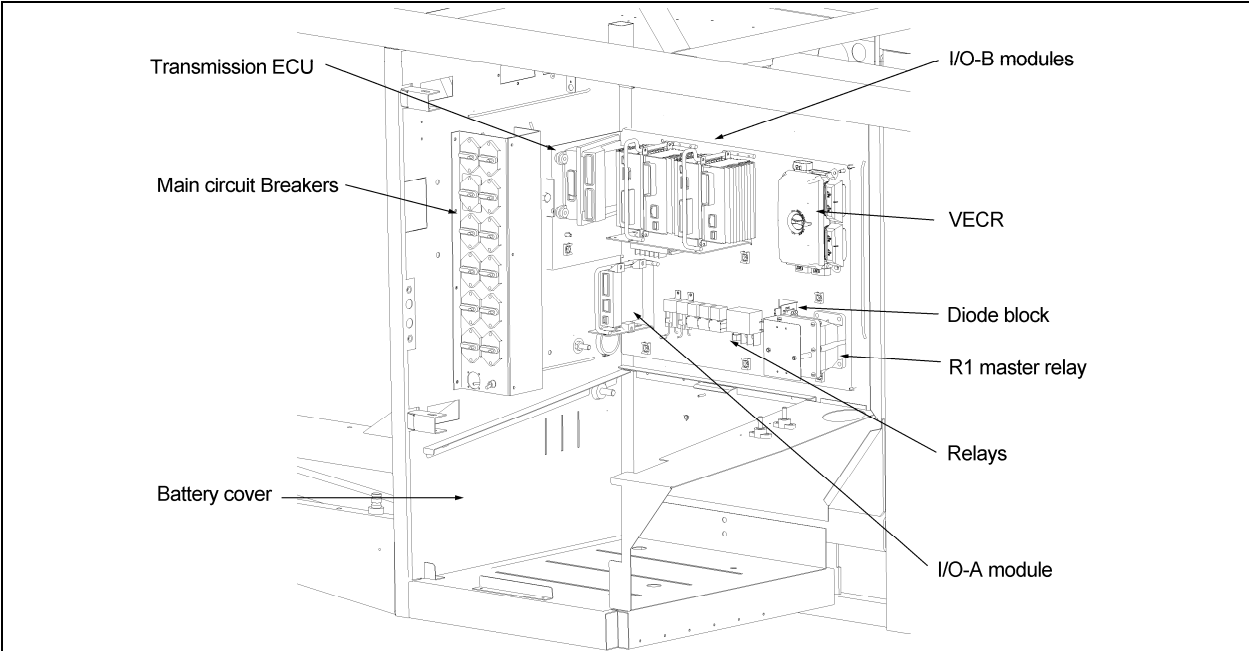

FIGURE 5: MAIN POWER COMPARTMENT (PARTIAL VIEW)

06594

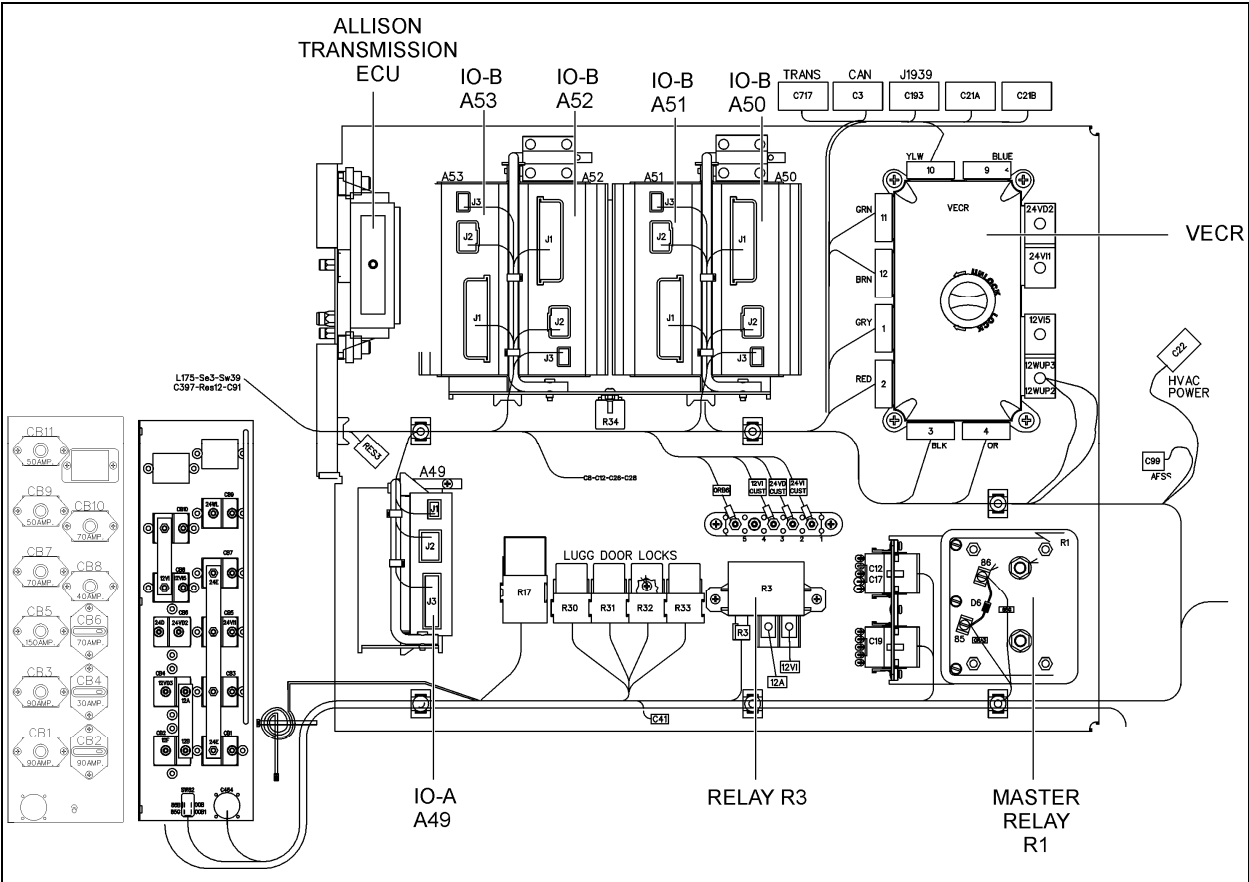

FIGURE 6 : MAIN POWER COMPARTMENT

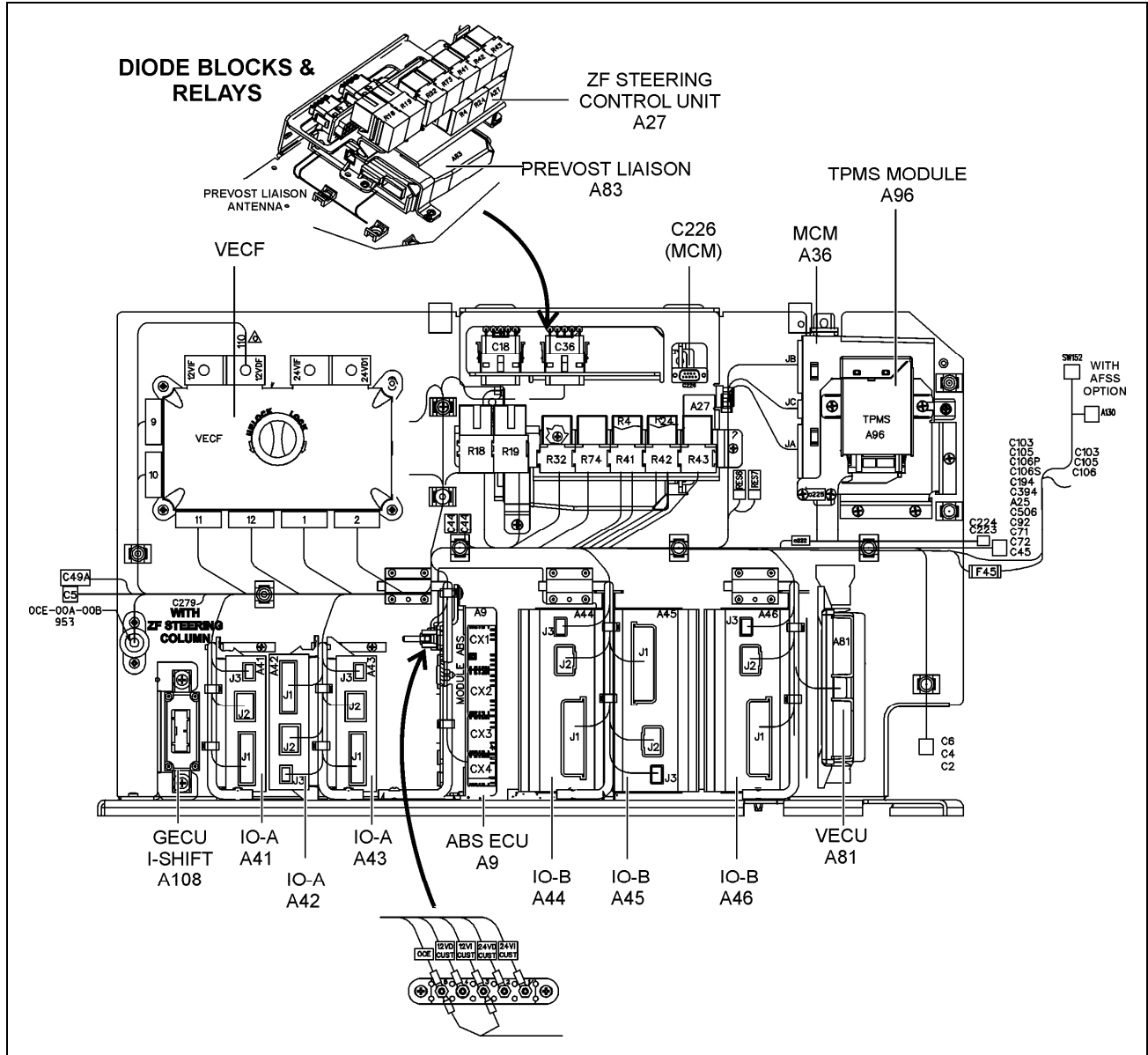

FIGURE 7: FRONT ELECTRICAL AND SERVICE COMPARTMENT

2.2.1 Battery Charger Or In-Station Lighting Connector

The vehicle may be equipped with a battery charger or in-station lighting connector. When it is connected to an external 110-120 VAC power source, the in-station lighting circuit can be energized without depleting the batteries. The receptacle is usually located on the main power compartment door or engine compartment R.H. side door.

2.3 FRONT ELECTRICAL AND SERVICE COMPARTMENT

The front electrical and service compartment is located on front L.H. side of vehicle. It contains the front junction panel with the following components (fig.7).

- Resistors;
- ABS module;
- Fuses;
- Relays;
- Kneeling audible alarm;

- Front multiplex modules;
- Front fuse box known as VECF (Vehicle Electrical Center Front);
- Emergency door opening unlock valve (coaches only);
- Windshield washer reservoir;
- Reclining bumper opening handle;
- Accessories air tank purge valve;
- Accessories system fill valve;
- Spare wheel support and rail (coaches only);
- Keyless entry system module (VIP only).

2.4 ENGINE REAR START PANEL

This control panel is located in the R.H. side of engine compartment near the engine oil reserve tank. This control panel includes the engine starter selector switch, as well as the rear start push button switch to start engine from engine compartment.

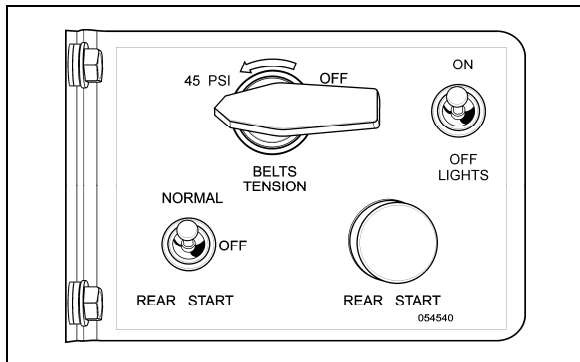

FIGURE 8: ENGINE REAR START PANEL 01044

2.5 A/C AND HEATING CONTROLS

The following components are located in the main power compartment (fig.5).

The following components are located in the front electrical and service compartment (fig.7).

The following components are located in the Evaporator Compartment (HVAC). They are mounted on a panel located on the R.H. side wall when facing the compartment (fig.9).

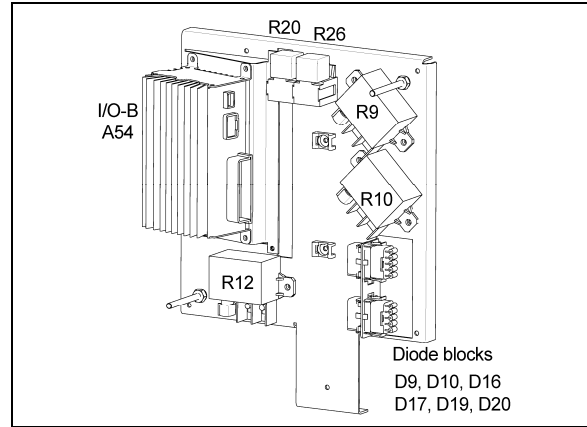

FIGURE 9: HVAC PANEL IN EVAPORATOR COMPARTMENT 06596

Each relay or resistor is identified to facilitate its location (fig.9).

NOTE

It is important when checking the A/C and heating system to keep the condenser compartment door closed in order to avoid faulty readings.

2.6 PNEUMATIC ACCESSORY PANEL

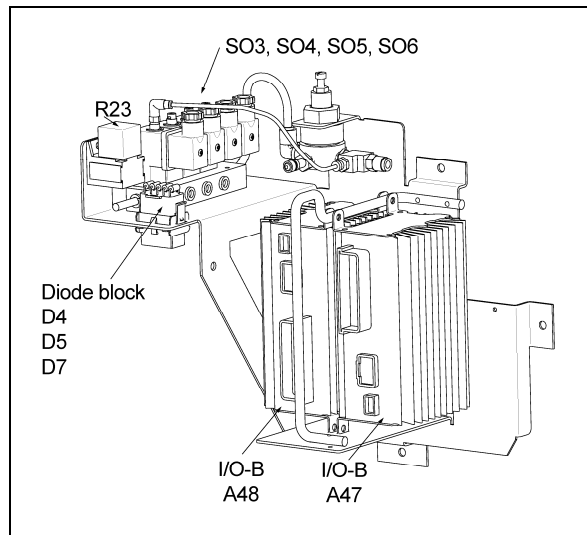

FIGURE 10 : PNEUMATIC ACCESSORY PANEL 06597

To access the pneumatic accessory panel of the right console, remove the panel under the larger utility compartment at the right of the dashboard.

Section 06: ELECTRICAL

3 BATTERIES

The battery has four (4) major functions:

1. Providing a source of current for starting the engine.
2. Stabilizing the voltage in the electrical system.
3. Supplying current for a limited time, when electrical demands of the equipment exceed the power output of the alternator.
4. Providing a limited source of power for connected accessories, when the engine is not running.

Two types of batteries are available.

- Standard acid-lead Group 31 maintenance free batteries
- AGM Spill proof batteries provided with optional PRIME energy management system.

3.1 GROUP 31 ACID-LEAD BATTERY

The vehicle is provided with four (4) 12-volt heavy-duty batteries connected in series-parallel. The top-mounted negative and positive terminals are tightly sealed to prevent leaks. Water never needs to be added to this type of battery.

There are no filler caps in the cover. The battery is sealed, except for small vent holes in the cover. The vents must not be restricted as they allow small amounts of gases produced in the battery to escape. The special chemical composition inside the battery reduces gassing to a very small amount at normal charging voltages. Besides reducing gassing, the special chemistry greatly reduces the possibility of overcharge damage.

The vents require keeping the battery in an upright position to prevent electrolyte leakage. Tipping the battery beyond a 45° angle in any direction can allow a small amount of electrolyte to leak out of the vent holes.



WARNING

DO NOT tip battery by more than 45° when carrying or installing the battery.

NOTE

Evidence of electrolyte leakage does not necessarily mean the battery is defective.

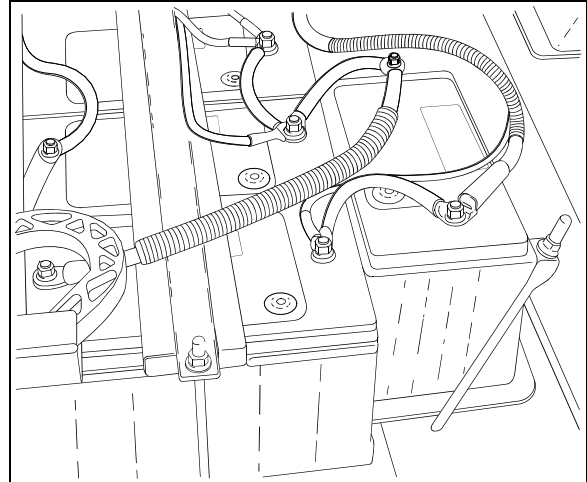

FIGURE 11: BATTERIES

06343

With special cables properly attached to the batteries, the metal surfaces that carry the current are completely sealed from the atmosphere. This prevents terminal oxidation and corrosion that may cause starting and charging problems.

If new cables are required, sealed terminal cable replacements should be used to retain the reliability of the original connections.



DANGER

All lead-acid batteries generate hydrogen gas, which is highly flammable. If ignited by a spark or flame, the gas may explode violently, causing spraying of acid, fragmentation of the battery, which may result in severe personal injuries. Wear safety glasses and do not smoke when working near batteries. In case of contact with acid, flush immediately with water.

3.2 GROUP 31 AGM BATTERIES

If your vehicle is equipped with PRIME energy management system, it is provided with four (4) Absorbed Glass Mat (AGM) 12-volt batteries connected in series-parallel.

These batteries require no maintenance for their lifetime. They can withstand deeper discharge cycles and several times the charging cycles of a standard battery.

These are sealed, valve regulated recombinant batteries which means that the oxygen created will recombine with the hydrogen in the battery, creating water and preventing water loss. Water never needs to be added to this type of battery.

The top-mounted negative and positive terminals are tightly sealed to prevent leaks.

The electrolyte in this type of battery is absorbed in micro-porous glass separators. This design prevents spills and results in greater resistance to vibration.

Always replace these batteries with identical make and model batteries as the system is balanced and optimized for this type of battery.

	<h3>CAUTION</h3>
<p>Replace only with AGM type batteries of the same specification and capacity.</p> <p>PRIME system is programmed for the charging capacity of the batteries installed.</p> <p>Installing a higher capacity battery will affect the battery life as the system will not fully charge the batteries, which is detrimental to battery performance.</p> <p>Refer to "Specifications" at the end of this section for further details.</p> <p>AGM batteries should be replaced in pairs or four at a time.</p>	

	<h3>CAUTION</h3>
<p>AGM (Absorbed Glass Mat) batteries require a voltage-limited charger, ideally fitted with a battery temperature sensor for temperature correction of charging parameters.</p> <p>Charge voltage: 13.8-14.6 Volt @77°F (25°C)</p> <p>Float voltage: 13.4-13.6 Volt @77°F (25°C)</p> <p>Charging AGM battery on a typical constant current or taper current charger – even one time – may greatly shorten its life.</p>	

3.3 BATTERY DISCHARGE PROTECTION

To prevent discharge of the batteries when the engine is not running, some functions are automatically switched off if the battery voltage drops below 24 volts for more than 30 seconds. The "Battery Voltage Warning" pictogram will show on the DID. Set the ignition key to the OFF position and then turn the ignition key to the ON position to reactivate the functions for a period of 30 seconds before they switch off again.

If a prolonged use of the functions with the engine not running is necessary, connect the battery to a charger.

3.4 MAIN BATTERY RELAYS

Main battery relays (12-volt and 24-volt) are provided for this vehicle. The relays are located in the main power compartment. The 24-volt battery relay engages when ignition key is in the ON or ACC position and battery master switch is flipped ON.

When the main battery relays are turned to the OFF position, all electrical supply from the batteries is cut off, with the exception of the following items.

- Battery equalizer check module;
- Engine Control Module;
- TCM power (Allison transmission);
- Preheater electronic timer;
- Preheater and water recirculating pump;
- Sedan entrance door;
- Radio memory;
- MCM;
- Cluster memory.

3.5 BATTERY REMOVAL AND INSTALLATION

1. Remove the two screws at the bottom of the plastic protective cover. Unscrew the two quarter turn nuts to remove the protective cover.
2. Remove supports. Unscrew terminal nuts of each defective battery.

	<h3>DANGER</h3>
<p>To prevent possible electric shock or sparking, the main battery relays should be in the "Off" position before disconnecting cables from the batteries.</p>	

3. Remove battery cables from the batteries.

<h3>NOTE</h3>
<p><i>When the battery cables have been removed from the batteries, wrap the battery terminals and cable ends with electric tape to prevent accidental grounding. The ground cables should always be disconnected first and</i></p>

Section 06: ELECTRICAL

replaced last.

4. Remove batteries.
5. Installation is the reverse of removal. Connect the red (24-volt) battery cables first, then the yellow (12-volt) battery cables and finish with the black (ground) cables. Tighten battery terminal nuts 10-15 lbf-ft.

NOTE

In replacing batteries, only batteries of the same specification should be used. Refer to "Specifications" at the end of this section for further details.

NOTE

When reinstalling batteries, battery connections must be tightened to 10-15 lbf-ft (13-20 Nm).



CAUTION

Ensure that connections are not reversed when reinstalling batteries, since damage to electrical system components will result.



DANGER

To prevent possible electric shock or sparking, the main battery relays must be set to the "Off" position before tightening an electrical connection.

NOTE

A protective coating should be applied on certain power connections that have been disconnected. Refer to Procedure PR00002E included at the end of this section to know the recommended products and where they are used.

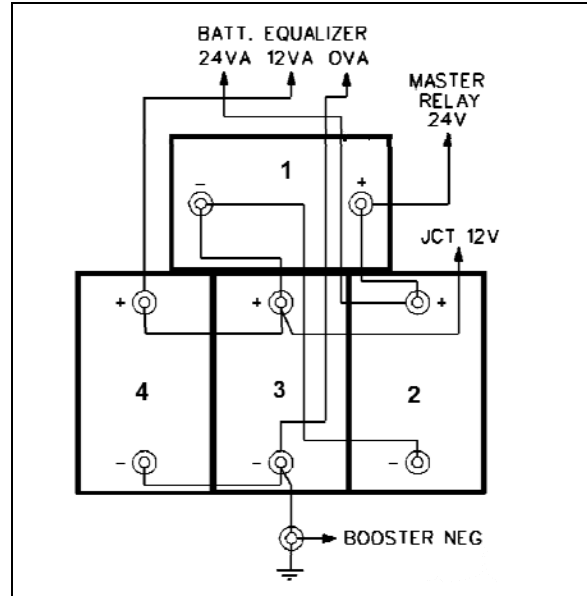

FIGURE 12 : BATTERY CONNECTIONS (STANDARD ACID-LEAD GROUP 31)

06597

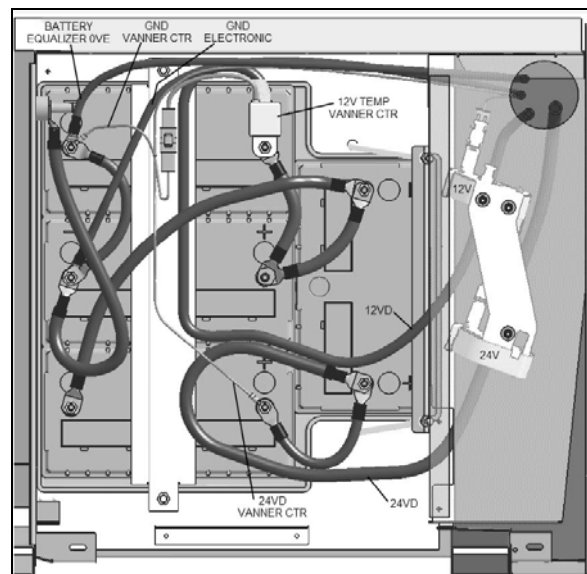

FIGURE 13: AGM BATTERY CONNECTIONS WITH PRIME

3.6 BATTERY RATING

Each of the 12-volt batteries used on the vehicle has the following rating:

Standard acid-lead battery

- Reserve capacity: 195 minutes
- Cold cranking (amps): 950 @ 0°F (-18°C)
- Cold cranking (amps): 745 @ -20°F (-29°C)
- Weight (filled): 59 lb. (26,7 kg)

AGM batteries (PRIME)

- Reserve capacity: 200 minutes

- Cold cranking (amps): 800 @ 0°F (-18°C)
- Weight (filled): 69 lb. (26,7 kg)

The reserve capacity is defined as the number of minutes a new, fully charged battery at 80°F (26,6°C) can be discharged at 25 amperes and maintain a minimum of 1.75 volts per cell (10.5 volts total for one 12-volt battery). This rating can be used as a basis for determining how long a vehicle might run after an alternator failure.

The cold cranking rating is defined as the minimum discharge current a battery will deliver in amperes for 30 seconds at 0 F (-18 C) while maintaining a minimum of 1.2 volts per cell (7.2 volts total for one 12-volt battery). This rating can be used as a basis for comparing starting performance.

3.7 BATTERY TESTING

3.7.1 Visual Inspection

1. Check the outside of the battery for a broken or cracked cover or case that could permit loss of electrolyte. If obvious physical damage is noted, replace the battery. Also, check for wet areas around the terminals.
2. Check for loose terminal posts, cable connections, damaged cables, and for evidence of corrosion. Correct conditions as required before proceeding with tests.
3. Check for damaged or loose battery tie-downs.

3.7.2 Removing Surface Charge

Disconnect cables from the battery and attach alligator clamps to the contact lead pad on the battery as shown in figure 14. Connect a load equal to half the CCA across the terminal for 5 seconds to remove surface charge from the battery.

3.7.3 Load Test

This test is one means of checking the battery to determine its ability to function as required in the vehicle.

To make this test, use test equipment that will withstand a heavy electrical load from the battery, such as a carbon pile resistor along with an ammeter and volt meter. Charging system analyzer test equipment may also be used.

1. Connect a voltmeter, ammeter, and a variable load resistance as illustrated in figure 14.

⚠ CAUTION

Observe polarity of the meters and the battery when making connections, and select the correct meter range.

2. Apply a load equal to half the CCA rating at 0°F for 15 seconds.
3. With an ammeter reading specified load, read voltage. The voltage should be at least 9.6 volts. Disconnect the load. If the voltmeter indicates 9.6 volts or more, the battery is good. If the voltmeter reading is less than 9.6 volts, replace the battery. This voltage is to be used for battery ambient temperatures of 70°F (21°C) and above. For temperatures below 70°F (21°C), refer to the following "Voltage and Temperature Chart".

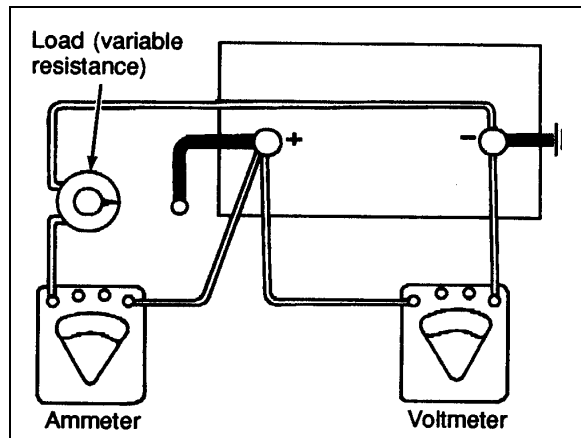

FIGURE 14: LOAD TEST 06064

NOTE

The accuracy of this test procedure is dependent upon close adherence to the proper load, time and temperature specifications.

Voltage and Temperature Chart

Ambient Temperature	Minimum Voltage
70°F (21°C) and above	9.6
60°F (16°C)	9.5
50°F (10°C)	9.4
40°F (4°C)	9.3
30°F (-1°C)	9.1

Section 06: ELECTRICAL

20°F (-7°C)	8.9
10°F (-12°C)	8.7
0°F (-18°C)	8.5

3.7.4 Testing Battery Cables

Check all cable ring terminals and connections to determine if they are in good condition. Excessive resistance, generally caused by poor connections, produces an abnormal voltage drop which may lower voltage at the starter to such a low value that normal operation of the starter will not be obtained. An abnormal voltage drop can be detected with a low-reading voltmeter as follows:



DANGER

To prevent the engine from starting, remove fuses F78 & F79 located in the VECR. Once these tests are completed, reinstall F78 & F79.

1. Check voltage drop between grounded (negative) battery terminal and vehicle frame by placing one prod of the voltmeter on the battery terminal and the other on a good ground (unpainted surface) on the vehicle. With the starter cranking the engine at a temperature of 70°F (21°C), voltage reading should be less than 0.3 volt. If the voltage reading exceeds 0.3 volt, there is excessive resistance in this circuit.
2. Check voltage drop between the positive battery terminal and the starter positive terminal stud while the starter motor is operated. If the reading is more than 2.5 volts, there is excessive resistance in this circuit.

NOTE

If it is necessary to extend the voltmeter lead for this test, use a #16 (AWG) or larger wire.

3. Check voltage drop between the starter housing and a good ground on the vehicle. The reading should be less than 0.2 volt.



DANGER

Any procedure other than the following could cause personal injury or damages to the charging system resulting from battery explosion or electrical burns.

Wear adequate eye protection when working on or near the batteries. Ensure that metal tools or jumper cables do not contact the positive battery terminal (or a metal surface in contact with it) as a short circuit will result. Do not attempt to jump start a vehicle suspected of having a frozen battery because the battery may rupture or explode. Both the booster and discharged batteries must be treated carefully when using jumper cables. Follow exactly the procedure outlined later in this section, being careful not to cause sparks.

3.8 BATTERY CHARGING



DANGER

During charging of the batteries, an explosive gas mixture forms in each cell. Part of this gas escapes through the vent holes and may form an explosive atmosphere around the battery itself if ventilation is poor. This explosive gas may remain in or around the battery for several hours after it has been charged. Sparks or flames can ignite this gas causing an internal explosion, which may shatter the battery.

Do not smoke near a battery which is being charged or which has been recently charged.

Do not break live circuits at battery terminals because a spark usually occurs at the point where a live circuit is broken. Care must always be taken when connecting or disconnecting booster leads or cable clamps on chargers. Poor connections are a common cause of electric arcs, which cause explosions.

The electrical system on this vehicle is negative ground. Installing the batteries with the positive terminals grounded or incorrect use of the booster battery and jumper cables will result in serious damage to the alternator, batteries and battery cables.

The batteries used on this vehicle can be charged either on or off the vehicle; however, when they are removed from the vehicle, it is recommended that an adapter kit, which is available from any "A/C DELCO" dealer, be used in charging sealed-terminal batteries. Use the booster block to charge the batteries when they are left on vehicle and **make sure that the main battery disconnect switch is set to the "On" position.**

The alligator clamps of the tester or charger must be placed between the terminal nuts and the lead pads of the terminal studs (Fig. 15) after the vehicle cables are detached. The alligator clamps should make firm contact with the lead pads.

NOTE

If this connection cannot be made because of the alligator clamp design, the load value for testing must be reduced from 290 to 260 amperes.

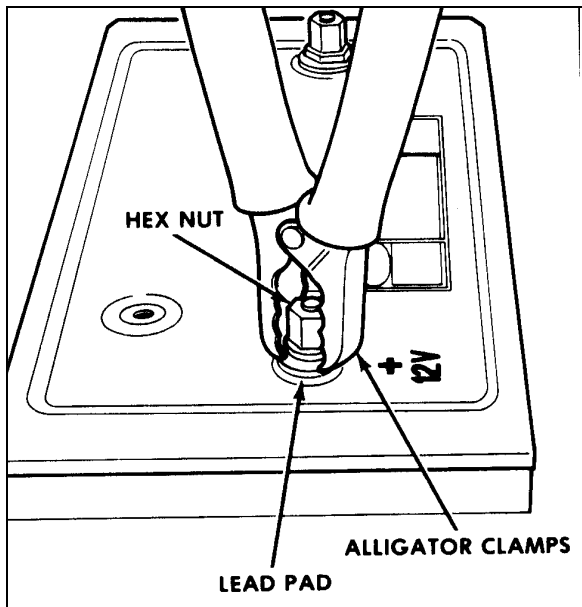

FIGURE 15: ALLIGATOR CLAMPS AND BATTERY 06065

A charge rate between 3 and 50 amperes is generally satisfactory for any maintenance-free battery as long as spewing out of electrolyte does not occur or the battery does not feel excessively hot (over 125°F (52°C)). If spewing out or violent gassing of electrolyte occurs or battery temperature exceeds 125°F (52°C), the charging rate must be reduced or temporarily stopped to allow cooling and to avoid damaging the battery.

Battery temperature can be estimated by touching or feeling the battery case.

**WARNING**

Always turn off the charger before connecting or disconnecting to a battery.

NOTE

The charge rate must be doubled when the batteries are charged by the booster block, because of the series-parallel circuit.

Battery charging consists of a charge current in amperes for a period of time in hours. Thus, a 25 ampere charging rate for 2 hours would be a 50 ampere-hour charge to the battery.

3.8.1 Battery Charging Guide**NOTE**

AGM (Absorbed Glass Mat) batteries require a voltage-limited charger, ideally fitted with a battery temperature sensor for temperature correction of charging parameters. *Do not manually charge AGM batteries. Look for the following voltage values on your voltage-limited charger.*

Charge voltage: 13.8-14.6 Volt @77°F (25°C)

Float voltage: 13.4-13.6 Volt @77°F (25°C)

Charging AGM battery on a typical constant current or taper current charger – even one time – may greatly shorten its life.

Fast Charging Rate

3-3/4 hours @ 20 amps

2-1/2 hours @ 30 amps

2 hours @ 40 amps

1-1/2 hours @ 50 amps

Slow Charging Rate

15 hours @ 5 amps

7-1/2 hours @ 10 amps

The time required for a charge will vary according to the following factors:

Size of Battery

For example, a completely discharged large heavy-duty battery requires more than twice the recharging time of a completely discharged small passenger car battery.

Temperature

For example, a longer time will be needed to charge any battery at 0°F (-18°C) than at 80°F (27°C). When a fast charger is connected to a cold battery, the current accepted by the battery will be very low at first, and then in time, the battery will accept a higher rate as it warms.

State of Charge

For example, a completely discharged battery requires more than twice as much charge than a half-charged battery. Since the electrolyte is nearly pure water and a poor conductor in a

Section 06: ELECTRICAL

completely discharged battery, the current accepted is very low at first. Later, as the charging current causes the electrolyte acid content to increase, the charging current will likewise increase.

Charger Capacity

For example, a charger which can supply only 5 amperes will require a much longer period of charging than a charger that can supply 30 amperes or more.

3.8.2 Emergency Jump Starting With Auxiliary (Booster) Battery

 **DANGER**

Off-board battery charger with a start boost facility must not be used to jump start the vehicle. This could damage the electrical system.

Both booster and discharged batteries should be treated carefully when using jumper cables. A vehicle with a discharged battery may be started by using energy from a booster battery or the battery from another vehicle.

On H3 coaches, the booster block is located in the engine compartment, on the R.H. side and is accessible through engine R.H. side door.

 **DANGER**

Jump starting may be dangerous and should be attempted only if the following conditions are met:

The booster battery or the battery in the other vehicle must be of the same voltage as the battery in the vehicle being started, and must be negative grounded.

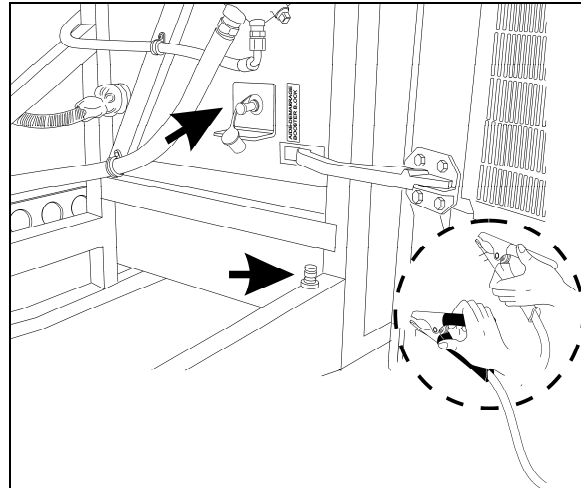



FIGURE 16: BOOSTER BLOCK

 **DANGER**

Follow the procedure exactly as outlined hereafter. Avoid making sparks.

Wear eye protection and remove rings, watches with metal bands and other metal jewelry.

Apply parking brake and place the transmission shift lever or push-button pads in Neutral (N) position in both vehicles. Turn off lights, heater and other electrical loads.

The following procedure should be used only when the batteries are discharged.

Do not attempt jump starting if you suspect the batteries are charged. Inspect the engine starting system prior to using this procedure.

1. Connect one end of one red jumper cable to the positive (+) terminal of the booster power source and the other end to the positive (+) post of the booster power block, located in the engine compartment R.H. side.
2. Connect one end of the remaining negative jumper cable (black) to the negative (-) terminal of the booster power source, and the other end of the black jumper cable to the negative (-) post of the booster power block.
3. Make sure the clips from one cable do not inadvertently touch the clips on the other cable. Do not lean over the battery when making connections. The ground connection must provide good electrical conductivity and current carrying capacity.
4. Start the engine in the vehicle that is providing the jump start. Let the engine run

for a few minutes, then start the engine in the vehicle that has the discharged batteries.

- When removing the jumper cables, perform the above procedure exactly in reverse order, and replace protective caps on booster block terminals.

 DANGER
<p>Any procedure other than the above could result in personal injury, property damage due to battery explosion, or damage to the charging system of the booster vehicle or of the boosted vehicle.</p>

<p>NOTE</p> <p><i>Jumper cables must withstand 500 cranking amperes. If cable length is 20 feet (6m) or less, use 2/0 (AWG) gauge wires. If cable length is between 20-30 feet (6-9m), use 3/0 (AWG) wires.</i></p>
--

3.9 AGM BATTERY CHARGING PRECAUTIONS

AGM (Absorbed Glass Mat) batteries require a voltage-limited, temperature corrected charger.

Make sure your charger is multi-staged and minimally provides the following voltage values:

Charge stage voltage:

13.8-14.6 V @ 77°F (25°C)

Float stage voltage:

13.4-13.6 V @ 77°F (25°C)

Charging AGM battery on a typical constant current or taper current charger – even one time – may greatly shorten its life.

3.10 BATTERY EQUALIZATION AND AGM BATTERIES

Equalization is a controlled over charge. Conventional batteries may benefit from this procedure, stirring the chemistry of the entire battery it counters stratification (layers of different concentration of electrolyte), and also counters sulfating that may have accumulated on the battery plates.

AGM battery design prevents chemical unbalance of the electrolyte. Manufacturers of this type of battery generally do not recommend performing equalization.

3.11 CLEANING AND INSPECTION

The external condition of the battery and the battery cables should be checked periodically. The top of the battery should be kept clean and the battery hold-down clamp bolts should be kept properly tightened. For best results when cleaning the battery, wash first with a diluted solution of ammonia or soda to neutralize any acid present, and then wash out with clean water. The battery hold-down bolts should be kept tight enough to prevent the batteries from moving, but they should not be tightened to the point that excessive strain is placed on the battery hold-down cover (proper tightening torque: 45-55 lbf-in (5-6 Nm)).

To insure good contact, the battery cable ring terminals should be tight on the battery posts. If the posts or cable ring terminals are corroded, the cables should be disconnected and the posts and clamps cleaned separately with a soda solution and a wire brush. Install cable ring terminals on battery posts and tighten to a torque of 10-15 lbf-ft (13-20 Nm). Replace protective caps to prevent corrosion and sparks.

3.12 COMMON CAUSES OF BATTERY FAILURE

When a battery fails, the cause of failure may be related to something other than the battery itself. For this reason, when a battery failure occurs, do not be satisfied with merely recharging or replacing the battery. Locate and correct the cause of the failure to prevent recurrence. Some common external causes of battery failure are as follows:

- A defect in charging system such as high resistance or a faulty alternator or regulator. The dashboard ALTERNATOR telltale illuminates if one of the alternators is defective.
- A malfunction within the 12-volt system (equalizer).
- Overloads caused by a defective starter or excessive use of accessories.
- Dirt and electrolyte on top of the batteries causing a constant drain.
- Hardened battery plates, due to battery being in a low state of charge over a long period of time.



ALTERNATOR telltale

Section 06: ELECTRICAL

6. Shorted cells, loss of active material from plates.
7. Driving conditions or requirements under which the vehicle is driven for short periods of time.
8. A constant drain caused by a shorted circuit such as an exposed wire or water infiltration in junction boxes causing ground fault.
9. Extended operation of preheating system with engine not running.
10. Failing to close disconnect switches during the night.

3.13 TROUBLESHOOTING

If a battery is known to be good and then has not performed satisfactorily in service for no apparent reason, the following factors may reveal the cause of trouble:

1. Vehicle accessories and disconnect switches inadvertently left on overnight.
2. Defects in the charging system, such as high wiring resistance, faulty alternator, regulator or battery equalizer.
3. A vehicle electrical load exceeding the alternator (or battery equalizer) capacity, with the addition of electrical devices, such as CB radio equipment, a cellular phone or additional lighting systems.
4. Defects in the electrical system, such as shorted or pinched wires.
5. Extended driving at slow speed while using many accessories.
6. Loose or poor battery cable-to-post connections, previous improper charging of a run-down battery or loose hold-down clamp bolts.
7. High-resistance connections or defects in the cranking system.

3.14 "BATTERY VOLTAGE WARNING" PICTOGRAM

If the "BATTERY VOLTAGE WARNING" (battery voltage incorrect) pictogram shows up in the DID (Driver Information Display), use the DID voltmeter gauge to determine if the battery voltage is too high or too low.



BATTERY VOLTAGE WARNING pictogram

3.14.1 Voltmeter Gauge Definitions

Voltmeter drops below 24 volts dc

- Check alternator output.
- Check voltage regulator.
- Check battery connections.
- Check battery cells.
- Check battery equalizer connections.

Voltmeter exceeds 30 volts dc

- Check alternator output.
- Check voltage regulator.
- Check battery connections.

Battery Balance

NOTE
<i>Allow at least 15 minutes to balance batteries after any corrective measure has been taken.</i>

1. Batteries out of balance (difference greater than 1.5 volts between the two battery banks).
 - Check battery equalizer connections.
 - Check equalizer cables for proper gauge.
 - Check battery connections.
2. Demand for 12-volt power exceeding rated amperage output of battery equalizers causing batteries to go out of balance.
 - Reduce 12-volt load or install additional battery equalizer(s).

4 PRIME ENERGY MANAGEMENT SYSTEM

4.1 DESCRIPTION

PRIME stands for Power Recovery by Intelligent Management of Energy.

This system focuses on eliminating parasitic loads on the engine by intelligent management of the alternators and air compressor duty cycle.

Instead of constantly charging, the alternator uses engine negative torque (braking, deceleration) to generate free electricity.

Depending on the air requirement, PRIME will also trigger the production of compressed air on negative torque.

PRIME also introduces maintenance-free Absorbed Glass Mat (AGM) batteries and a new

Vanner 80 series battery equalizer that monitors battery State of Charge (SOC).

Battery temperature, voltage and current are also monitored to prevent overcharging and overheating.

Maximum fuel economy is obtained on a ride when the mix of hilly and flat portions allows the batteries to be charged when the vehicle is in free wheel. It basically means that batteries are charged with free energy and that no fuel consumption is dedicated to charge the batteries.

4.2 COMPONENTS

New components includes AGM batteries, a Vanner Battery equalizer, a temperature sensor located on the battery post and two voltage and current sensors monitoring 12V and 24 V circuits.

The compressor duty cycle control is achieved by an electric air dryer. This is covered in section 12 of this manual.

4.3 DID DISPLAY

In the DID you will find the percentage of trip made with regenerated electricity displayed along with the instantaneous fuel consumption.

This value is reset each time the engine is restarted.

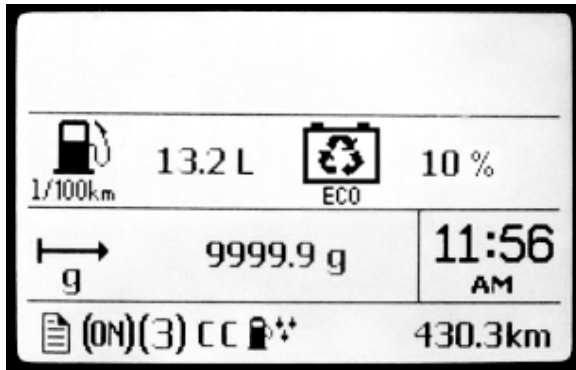

FIGURE 17: PRIME DID DISPLAY

In addition to the standard voltage gage, the DID also includes a state of charge gage for the batteries:

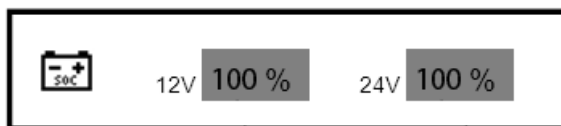

FIGURE 18: Battery state of charge

This gage displays the level of charge for the 12V and 24V battery banks in percentage.

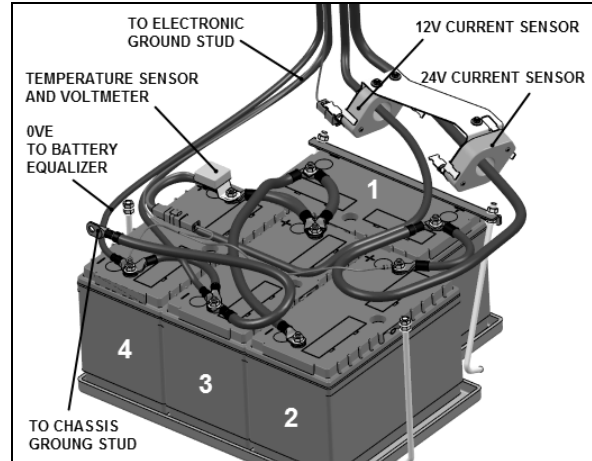

FIGURE 19: BATTERY ARRANGEMENT WITH PRIME

5 TROUBLESHOOTING AND TESTING THE MULTIPLEX VEHICLES

5.1 PROBING VOLTAGE ON THE MULTIPLEX CIRCUITS

Some Multiplex modules are supplied by 12 volts while others are supplied by 24 volts. The 12-volt or 24-volt information is found on the modules symbol in the wiring diagram. Before taking voltage readings to track the source of a problem, first verify if the module is supplied by 12V or 24V, if not, residual voltage on the module inputs/outputs can draw an erroneous conclusion.

Inactive Multiplex output = Residual voltage of 18% to 33% of supply voltage.

Inactive Multiplex input = Residual voltage of 50% of supply voltage.

NOTE
<ul style="list-style-type: none"> Verify on the wiring diagram whether the voltage is 12V or 24V, For a 12V module: an active voltage would be 12V or 0V but not in between. If you measure the intermediate tensions (ex. 6V, 2V, or 4V) this must be interpreted as if the input or the output is inactive. For a 24V module: an active voltage would be 24V or 0V but not in between. If you measure the intermediate tensions (ex. 12V, 4V, or 8V) this must be interpreted as if the input or the output is inactive.

5.2 CAN NETWORK

Section 06: ELECTRICAL

The CAN link wiring is separated in sections and uses connectors that are not shared with other circuits. This allows sections of the network to be isolated to help locate short-circuit on the CAN.

In case of a short-circuit on the CAN link, this affects all the modules and they all show “No Response” in the error messages of the “ELECTRICAL SYSTEM” menu. To locate a short-circuit, proceed by disconnecting one module zone at a time while verifying if this makes inactive the errors in the modules still connected. Connector C1 (front electrical & service compartment) disconnects all the modules at the rear of the vehicle from the network. Connector C5 (front electrical & service compartment) disconnects all the modules from the right-hand console. Connector C100 disconnects the modules from the evaporator compartment. Connector C3 (main power compartment) disconnects the modules from the battery compartment.

Example: Disconnect C5 and C1 and then verify the status of the errors. If the front modules (A41 to A46) now give inactive errors, which means short-circuit is elsewhere than in the front electrical & service compartment.

5.2.1 Spare Can

A spare CAN network is installed between the front and the rear of the vehicle. It has connectors installed at each end to facilitate swapping from the regular CAN network to the spare CAN network. Refer to the vehicle wiring diagram and paragraph 4.6 for more information.

5.3 ELECTRICAL SYSTEM DIAGNOSTIC

Using the Driver Information Display (DID), check if there are active errors for the vehicle electrical system. With the DIAGNOSTICS menu, highlight FAULT DIAGNOSTICS and then highlight ELECTRICAL SYSTEM to request a diagnostic of the electrical system. Press the enter key. If applicable, the DID shows the multiplex device ID, the fault messages or fault codes recorded. When more than one fault is recorded, an arrow pointing down appears on the right of the display. Use the down arrow to see all the fault messages.

Once the problem corrected, the DID still shows the fault as being active. You have to leave the FAULT DIAGNOSTICS menu, wait approximately 20 to 30 seconds and then return to FAULT DIAGNOSTICS to request a new diagnostic of the ELECTRICAL SYSTEM. The DID should display the fault as being inactive.

The MCM can store up to 20 faults, i.e. the first 10 and the last 10. Middle faults will be erased. If the breakers are tripped, the fault history will be erased from the MCM memory.

NOTE

When performing an electrical system diagnostic with the DID, the message « No Response ModA41 » indicates either module A41 is not responding due to a CAN link problem or module A41 is not powered. Similar messages exist for all modules (A42, A43, A44, etc.).

NOTE

Because it is easier to do, check first if the module is powered by probing on its gray connector. If it is, then you can conclude that there is a CAN link problem. Refer to CAN NETWORK LAYOUT AND TROUBLESHOOTING in this section.

NOTE

The Driver Information Display (DID) is the most important tool to achieve troubleshooting on a multiplex vehicle.

5.4 MULTIPLEX INPUT TEST MODE

The multiplex input test provides useful information to diagnose multiplexed inputs of switches and sensors, complimentary to the electrical system diagnosis.

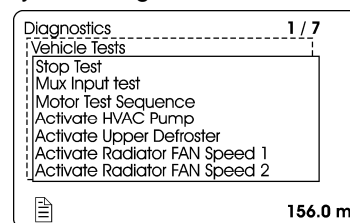

To initiate the test mode, use the Driver Information Display (DID) DIAGNOSTICS menu. Select VEHICLE TESTS submenu and then MUX INPUT TEST. Press ENTER button to start the test. The DID status line will show TEST to confirm the test mode is active. To exit test, press ESCAPE button, select STOP TEST submenu and then press ENTER button twice. TEST will disappear from the DID status line.

Instrument panel audible alarm emits a *beep* each time an OFF/ON transition is detected on a multiplex input. This allows quick verifying if the switches and sensors are detected or seen by the multiplex modules. When the vehicle is

parked, the back-up alarm also emits a *beep* that allows verification of the sensors at the rear of the vehicle.

Certain inputs are doubled (for example, turn signal switch on multi-function lever, door operating buttons) and also other inputs activate at the same time (ex. kneeling switch and Kneeling proximity sensor switch). For these inputs, 2 *beeps* are emitted. If only one *beep* is heard, one of the inputs is defective.

SWITCHES AND SENSORS SUPPORTED BY THE SWITCH/SENSOR TEST MODE
HVAC control unit driver's section ON/OFF
HVAC control unit driver recirculate switch
HVAC overhead compartment fan switch
HVAC control unit passenger's section ON/OFF
Radiator fan clutch switch
Engine rear start selector switch "rear start"
Engine rear start selector switch "normal"
Engine ignition front switch
Engine ignition rear switch
Entrance door inside opening /closing switch
Entrance door outside opening /closing switch
Electric horn button
Kneeling down switch
Kneeling up switch
Baggage compartment locking system switch
Baggage compartment door ajar open sensor
Steering wheel control buttons
Lavatory emergency switch
Interior lighting switch, 2 positions
Driver's area lighting switch
Reading lights switch
Multi-function lever LH turn signal
Multi-function lever RH turn signal
Fog lights switch
Hazard warning flashers switch
Multi-function lever courtesy blinkers switch
Headlights switch, 2 positions

Multi-function lever headlights beam toggle switch
Baggage compartment door lock/unlock switch
Tag axle lever
Wheelchair lift activation switch
Windshield lower wiper
Multi-function lever windshield wipers intermit.
Lower windshield wipers backup switch
Lower windshield washer switch
Upper windshield washer switch
Upper windshield wipers switch, 2 positions

The following inputs, either certain options or sensors which are difficult to activate, are not supported by the switch/sensor test:

- Service chime enable switch,
- Horn selector switch,
- Outside rear view mirror heat,
- Mirror control switches,
- Low-buoy switch,
- Starter sensor,
- ABS warning input,
- WCL switch,
- Driver's power window switch,
- Fog lights switch,
- Alternator sensors 1 & 2,
- Retarder active signal,
- Radiator fan speed 1 & 2 signals.

In test mode, with the parking brake applied and the passenger set point set to a value higher than 64°F (18°C), the circulator pump is not set to OFF as it would normally do when the outside temperature gets above 50°F (10°C). This feature allows verification of the pump when inside a garage. This is also useful when working on the heating system to remove air pockets trapped in the system.

When performing an A/C cooling test and having the water pump shut off is required, initiate the multiplex input test mode. While in this mode, just set the passenger set point temperature to the minimum 64°F (18°C) to shut off the pump.

Section 06: ELECTRICAL

5.5 MOTOR TEST SEQUENCE

This test mode allows testing of the electrical motors and electric contactors without the need to have the engine running. Note that while in test mode, the engine cannot be started.

Prerequisite conditions for the motor test mode:

- A. The battery charger must be connected to a 110-120 volt power supply. If not, the test will be interrupted when the voltage drops below 24 volts,
- B. Engine not running,
- C. Parking brake applied,

 **DANGER**

Before starting the test sequence, make sure nobody is working in the evaporator or condenser compartment.

NOTE

The back-up alarm will beep ten (10) times prior the test starts to warn people that may be working on the vehicle.

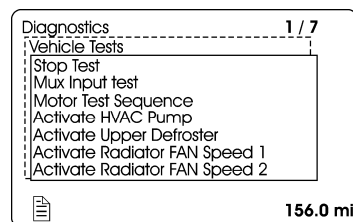

To enter this mode:

- Using the dashboard DID, select DIAGNOSTICS menu and press ENTER button ;
- Select VEHICLE TEST, press ENTER button then select MOTOR TEST SEQUENCE and press ENTER button to initiate the test mode for electrical motors;
- Ten (10) beeps can be heard indicating the motor test mode has started.

Using the test mode:

During the entire test, the instrument panel audible alarm gives a signal each second to remind that the motor test mode is underway.

5.5.1 Test Sequence – Coaches only

Go to the condenser compartment:

- The condenser fans start at speed 1, then after a short pause, speed 2 activates.
- The passenger's unit refrigerant solenoid valve activates.

Then 5 beeps can be heard from the back-up alarm to indicate to go to the engine compartment.

In the engine compartment, the sequence is as follows:

- Toilet fan motor starts.
- A/C compressor clutch activates 3 times.
- Left compressor unloader activates 3 times.
- Right compressor unloader activates 3 times.
- Fan clutch is disengaged (fan can be turned freely by hand).
- Fan clutch engages in speed 1 (fan can be turned by hand but with a certain resistance).
- Fan clutch engages in speed 2 (cannot be turned but hand).

5 beeps from the back-up alarm indicate to go to the evaporator compartment.

In the evaporator compartment:

- Evaporator fan motor runs at speed 1 for 3 seconds then runs at speed 2 for 2 seconds.
- Hot water pump starts running for 5 seconds and hot water pneumatic valve cycles 3 times.

5 beeps from the back-up alarm indicate to get to the driver's area inside the vehicle.

Inside the vehicle:

- The driver's HVAC unit refrigerant solenoid valve cycles 3 times and the hot water pneumatic valve cycles 3 times also.
- Left and right overhead compartment fans start running one after the other for 5 seconds.
- The upper windshield defroster (optional) starts running.

To exit the electric motors test sequence, press ESCAPE button, select STOP TEST submenu and then press ENTER button twice.

5.5.2 Test Sequence – VIP With Central HVAC System

Driver's & passenger's unit fresh air damper open. [20 seconds delay]

Go to the condenser compartment:

- Check the fans. The condenser motors start at speed 1 for 3 seconds, then after a short pause, speed 2 activates. [3 seconds delay]
- The passenger's unit refrigerant solenoid valve activates 3 times. [10 seconds delay]

Then 5 beeps can be heard from the back-up alarm to indicate to go to the engine compartment and main power compartment.

In the engine compartment, the sequence is as follows:

- The main power compartment door fan starts running for 3 seconds (will not run if door is open). [10 seconds delay]
- A/C compressor clutch activates 3 times.
- Left compressor unloader activates 3 times.
- Right compressor unloader activates 3 times. [5 seconds delay]
- Radiator fan clutch is disengaged (fan can be turned freely by hand). [3 seconds delay]
- Fan clutch engages in speed 1 (fan can be turned by hand but with a certain resistance). [3 seconds delay]
- Fan clutch engages in speed 2 (cannot be turned but hand). [10 seconds delay]

5 beeps from the back-up alarm indicate to go to the evaporator compartment.

In the evaporator compartment:

- Evaporator fan motor runs at speed 1 for 3 seconds then runs at speed 2 for 2 seconds.
- Hot water pump starts running for 5 seconds and hot water pneumatic valve cycles 3 times. [20 seconds delay]

5 beeps from the back-up alarm indicate to go to the spare wheel compartment behind the reclining bumper.

Inside the spare wheel compartment:

- Driver's unit refrigerant solenoid valve activates 3 times.
- Driver's unit hot water pneumatic valve cycles 3 times.
- Closing of the fresh air dampers.

To exit the electric motors test sequence, press ESCAPE button, select STOP TEST submenu and then press ENTER button twice.

5.5.3 Test Sequence – VIP With Small HVAC System

Driver's unit fresh air damper opening. [20 seconds delay]

Then 5 beeps can be heard from the back-up alarm to indicate to go to the engine compartment and main power compartment.

In the engine compartment, the sequence is as follows:

- The main power compartment door fan starts running for 3 seconds (will not run if door is open). [10 seconds delay]
- A/C compressor clutch activated 3 times. [5 seconds delay]
- Radiator fan clutch is disengaged (fan can be turned freely by hand). [3 seconds delay]
- Fan clutch engages in speed 1 (fan can be turned by hand but with a certain resistance). [3 seconds delay]
- Fan clutch engages in speed 2 (cannot be turned but hand). [10 seconds delay]

5 beeps from the back-up alarm indicate to go to the spare wheel compartment behind the reclining bumper.

Inside the spare wheel compartment:

- Auxiliary unit refrigerant solenoid valve activates 3 times. [10 seconds delay]
- Hot water pump starts running for 5 seconds.
- Driver's unit refrigerant solenoid valve activates 3 times.
- Driver's unit hot water pneumatic valve cycles 3 times.
- Closing of the fresh air dampers.

Section 06: ELECTRICAL

To exit the electric motors test sequence, press **ESCAPE** button, select **STOP TEST** submenu and then press **ENTER** button twice.

5.6 FORCED ACTIVATION OF THE RADIATOR FAN CLUTCH

To prevent the engine from overheating in case of malfunction of the clutch activation system, it is possible to force activation of the clutch.

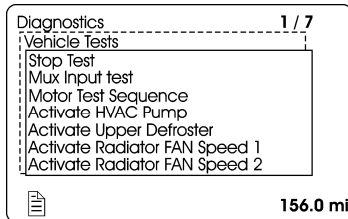

1. On the Driver Information Display, select **DIAGNOSTICS** menu. Select **VEHICLE TESTS** submenu and then **ACTIVATE RADIATOR FAN SPEED 1** or **ACTIVATE RADIATOR FAN SPEED 2** as required.
2. The DID status line will show **TEST** to confirm the forced activation of the radiator

fan clutch. To cancel, turn the ignition switch to the **OFF** position or press **ESCAPE** button, select **STOP TEST** submenu and then press **ENTER** button twice. **TEST** will disappear from the DID status line.

If the fan clutch does not engage using this procedure then the clutch is faulty or the wiring between the multiplex module and the clutch is faulty. Mechanically lock the fan clutch as described in section 05: **COOLING SYSTEM** of the maintenance manual.

5.7 CAN NETWORK LAYOUT AND TROUBLESHOOTING

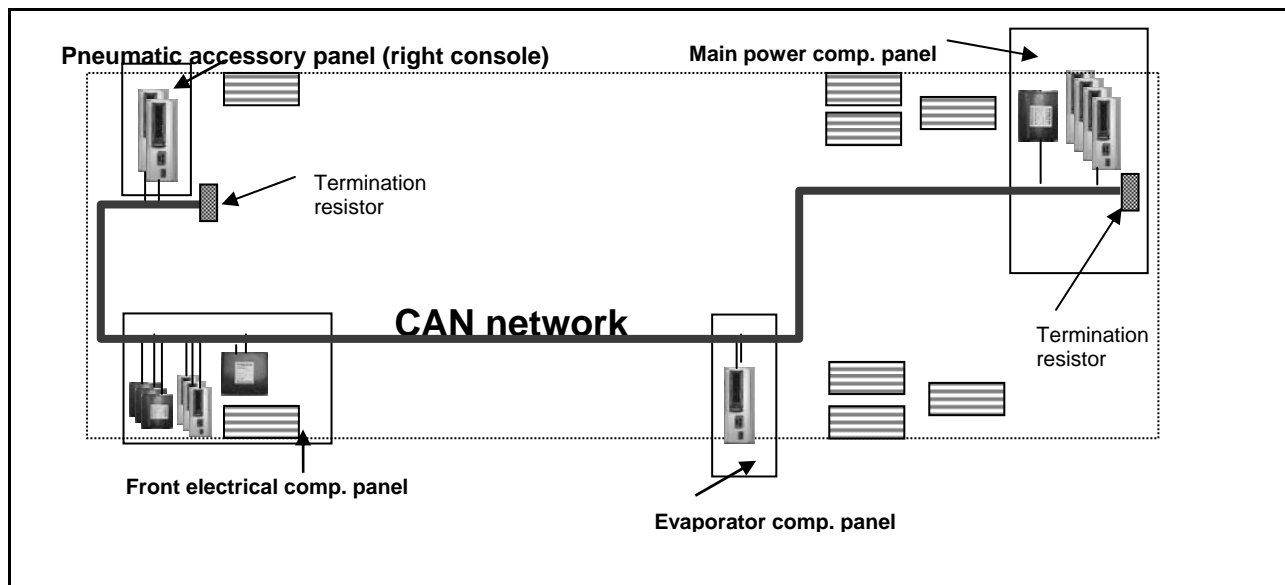

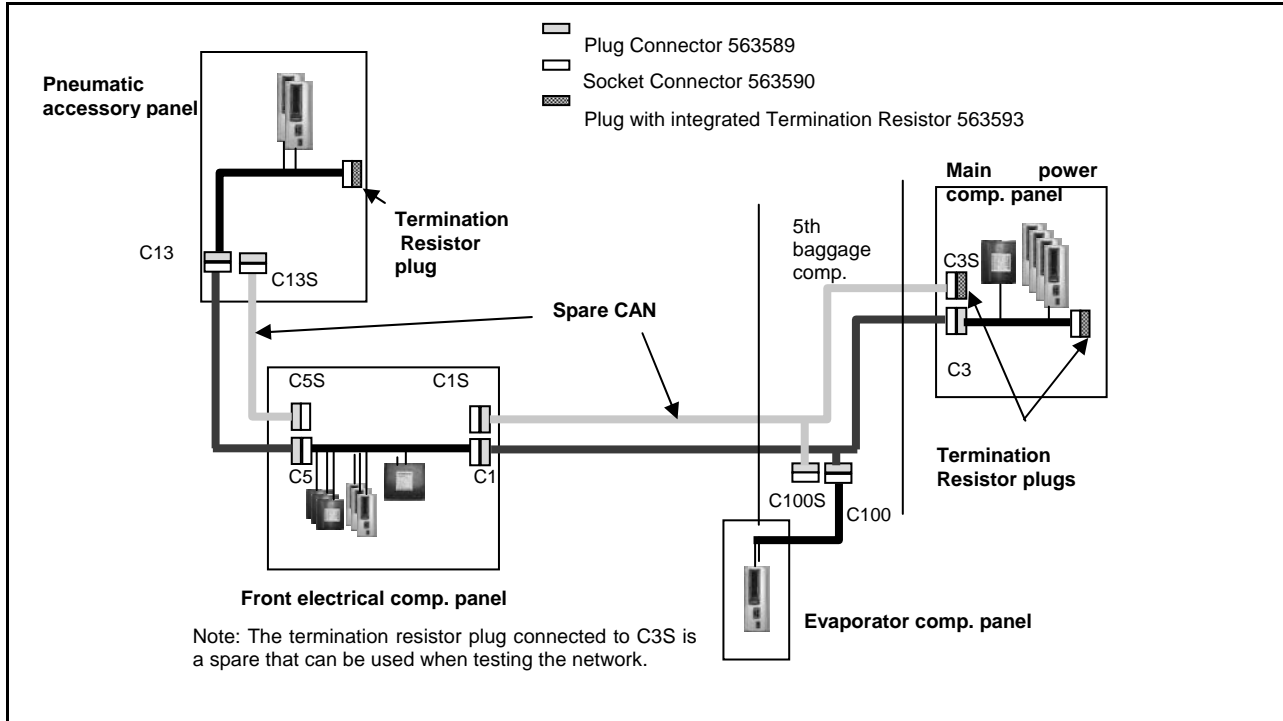

If all 14 modules (A41 to A54) are showed as Not Responding and Active Fault, the problem could be:

- A short circuit somewhere on the CAN network.
- The network is completely open circuit. That means none of the two termination resistors are connected.

Several simple tests can be done to locate the problem.

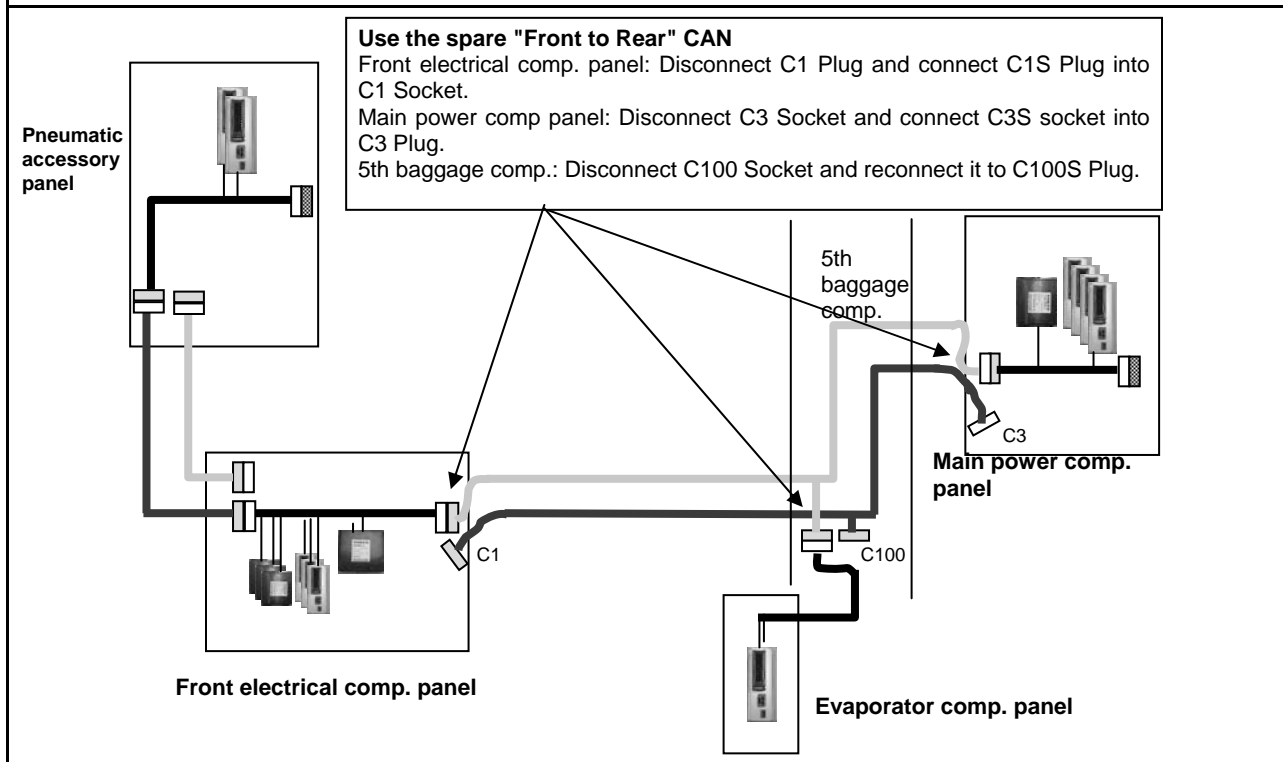

Section 06: ELECTRICAL

All modules including Wake-up modules and MCM have to be powered OFF prior to probe the CAN lines with an ohmmeter.

Probing the resistance between the CAN-H and CAN-L wire is a useful method to localize short circuits or open circuit on the CAN network. However, when doing so, make sure none of the modules connected to the CAN line are powered, including wake-up powered modules and battery direct supply module (MCM). Otherwise the measured value is invalid and will always show OL (Open Load). This is because the modules are applying a voltage on the CAN lines and this is fooling the ohmmeter.

Proceed as follow when probing the CAN line with an ohmmeter in order to get a valid reading:

- Turn ignition key to the OFF position.
- Set the battery master switch to the OFF position to turn all Wake-up modules power to OFF.
- Trip circuit breakers CB2, CB4 and CB6 to remove direct battery power from the MCM.

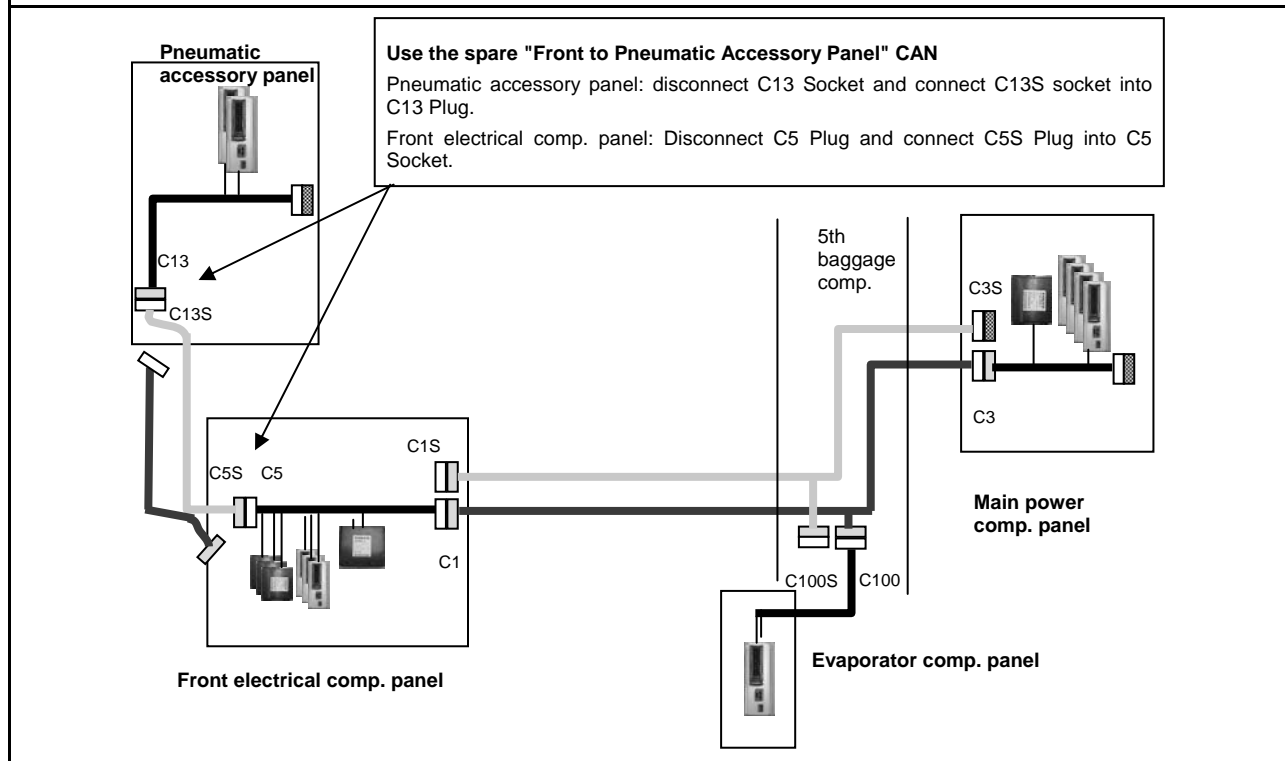

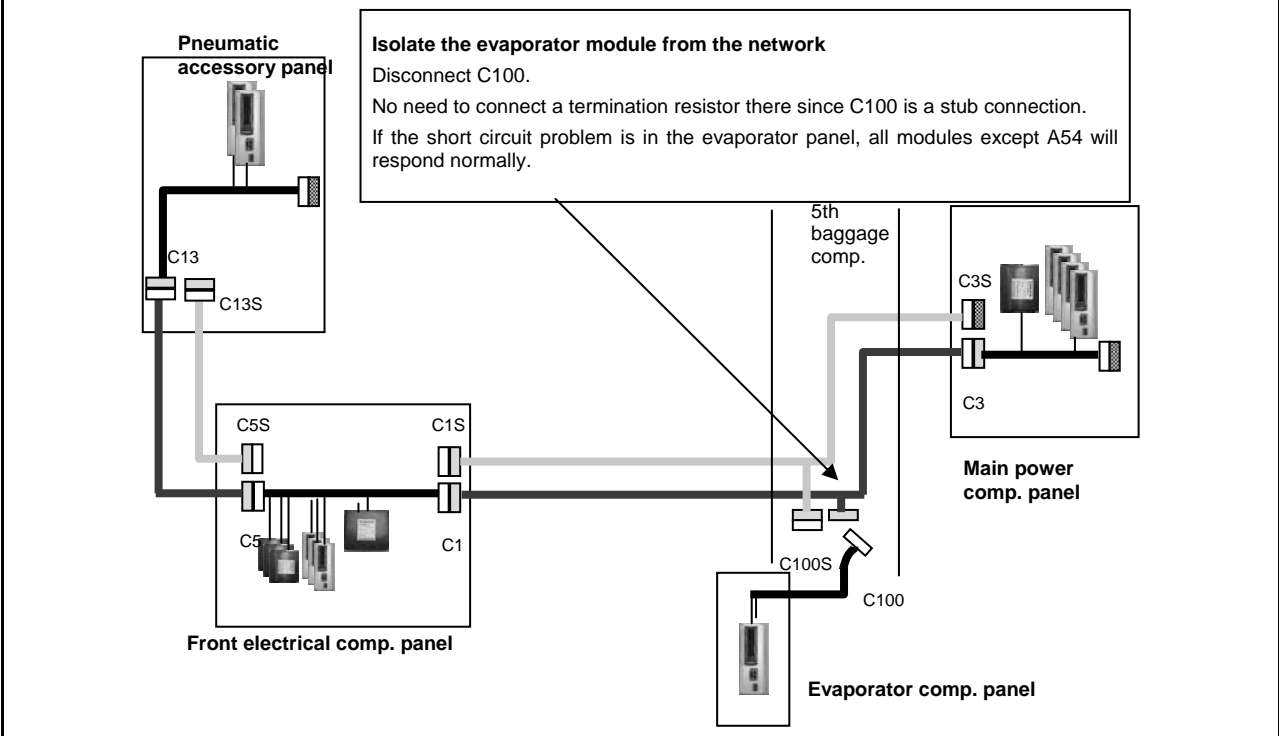
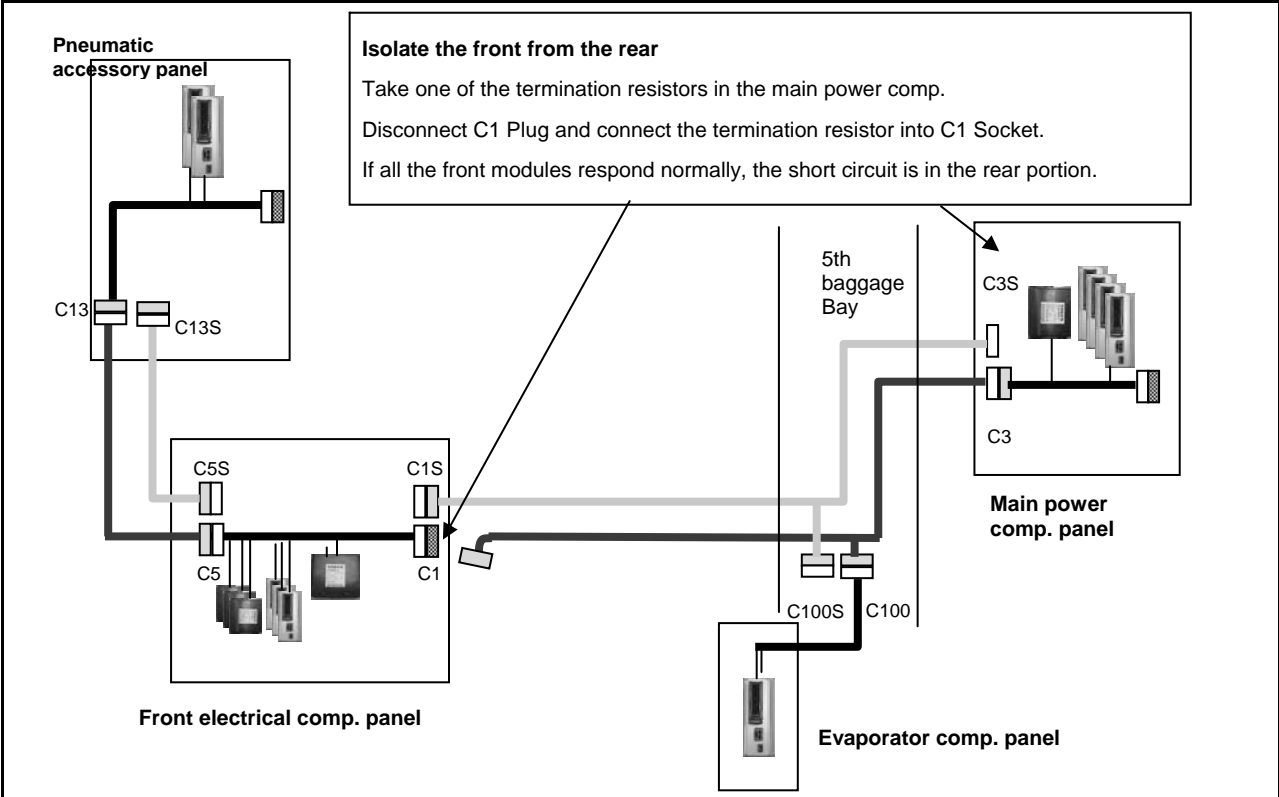

Section 06: ELECTRICAL

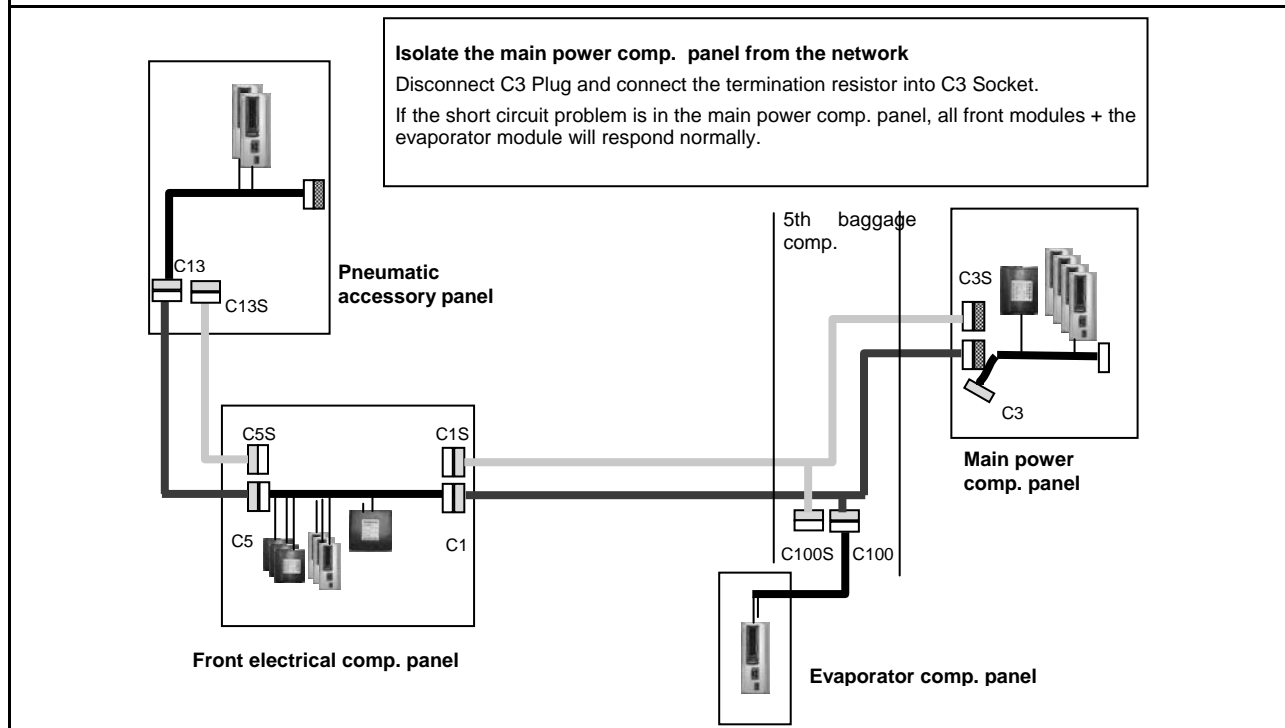
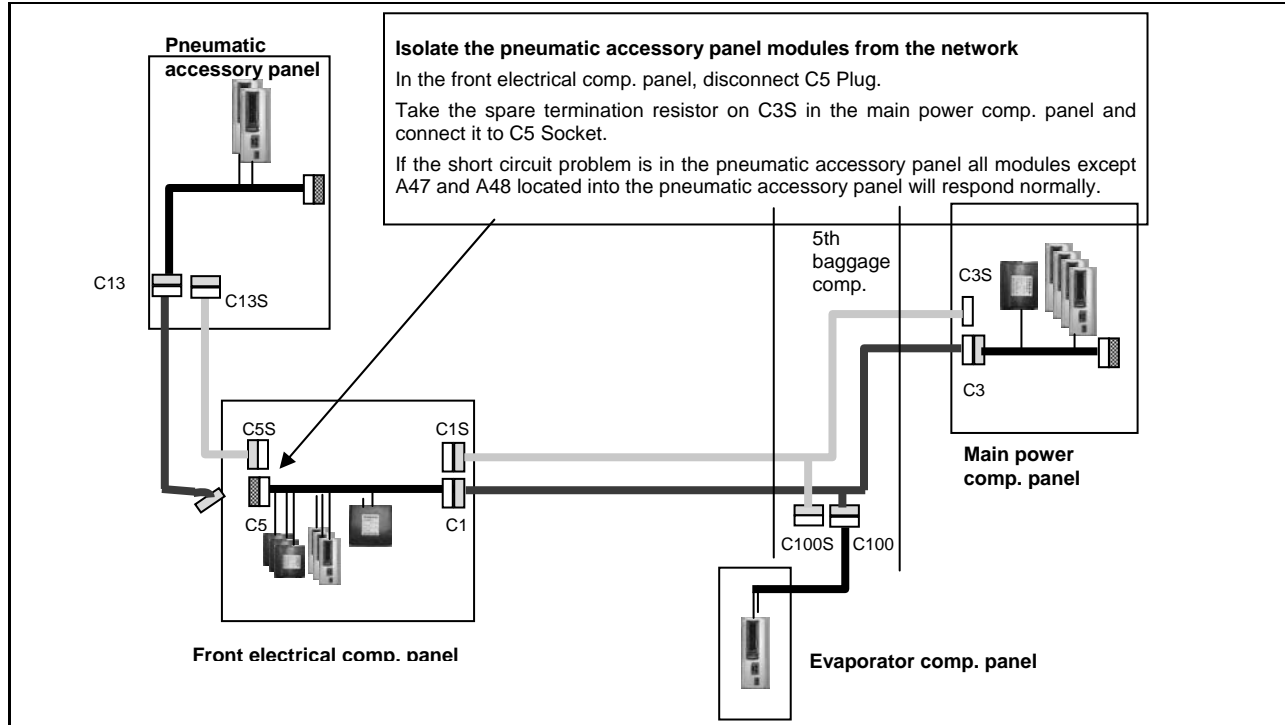

CAN wires are not like other common electrical wires.

- Maintaining a proper wire twisting is important. The two yellow and green wires must be twisted and in close contact all along the network to maintain the transmission line impedance.
- A slack handmade twisting is not acceptable.
- There should be no more than 50 mm (2 inches) without twist at the connection points.

We recommend replacing the CAN harnesses instead of trying to repair them.

5.8 ROADSIDE TROUBLESHOOTING

Problem/Symptom	Probable Causes	Actions
Vehicle does not Start	<p>Rear Start selector switch is not at the NORMAL position</p> <p>Battery master switch in the battery compartment is at the OFF position (down)</p> <hr/> <p>CAN network problem (Multiplex)</p> <p>Module A53 not powered or is defective</p> <p>Engine ECM does not receive the ignition signal</p> <p>Engine ECM is not powered</p>	<ol style="list-style-type: none"> 1. Check that the rear start selector switch is flipped up to NORMAL start position and battery master switch is flipped up to ON and retry cranking 2. Flip the rear start selector switch to "Rear Start" and start the vehicle from the rear <hr/> <p>If the vehicle does not start from the rear:</p> <ol style="list-style-type: none"> 1. Verify that module A53 is powered: <ol style="list-style-type: none"> a) Check DIAGNOSTICS menu of DID. Select FAULT DIAGNOSTIC and ELECTRICAL SYSTEM. The message "No Response ModA53, Active" indicates a power problem on the module or a CAN network problem. b) Check / reset circuit breaker CB5 c) Check / replace fuse F65 d) Probe gray connector on module to see if it is powered. 2. Verify that the engine ECM is powered and get the ignition signal <ol style="list-style-type: none"> a) Check / reset circuit breaker CB8 Check / replace fuse F74 b) Check / reset circuit breaker CB2 Check / replace fuse F78
<p>None of the Multiplexed functions are operating, including the basic limp-home functions (door opening, flashers, wipers in speed 1)</p> <p>"FLIP REAR BREAKER TO INITIATE I/O MODULES PROGRAMMING" pop-up message appears in the DID</p> <p><i>Note: The sunshades are still functioning since these are not multiplexed</i></p>	<p>The program version in the MCM is different than the program in the I/O modules and the MCM is forcing all I/O modules to stay inactive</p>	<ol style="list-style-type: none"> 1. Engage the auto-programming of the I/O modules: Turn the ignition key to the ON position, trip and reset circuit breaker CB6. 2. The DID indicates "MUX AUTOPROGRAMMING I/O MODULE PLEASE WAIT" until the reprogramming is complete.

Section 06: ELECTRICAL

Problem/Symptom	Probable Causes	Actions
<p>Many secondary functions (not essential for driving) not functioning (interior lighting, driver's area lighting, wiper speed 2 and intermittent)</p> <p>Marker lights and clearance lights are turned ON when setting ignition to the ON position</p>	<p>The MCM module does not receive 24 V power</p> <p>The CAN network is not working. It could be caused by a short on the network, an open circuit, a problem with the MCM or the MCM being disconnected from the network</p>	<ol style="list-style-type: none"> 1. Check / reset circuit breaker CB6 (4th from the top on the right side column) Check / replace fuse F1 2. Operate in limp-home mode by starting the vehicle from the engine compartment (REAR START). All functions essential to drive are available <p>To close and lock the door, pull the door manually up to its closed position and it will lock by itself. The door opening button is still functioning</p>
<p>No temperature control in the passenger area</p> <p>Passenger temperature display indicates two dashes "--"</p>	<p>Problem with the temperature sensor located in the evaporator compartment air intake or the sensor wiring</p>	<ol style="list-style-type: none"> 1. Instruct the driver to manually control the temperature by playing with the passenger set point. Set above 22°C (72°F) to heat and below 22° C (72°F) to cool
<p>Entrance door does not open nor close using the control buttons</p> <p>Defroster fan not functioning</p> <p>Lower windshield wipers not functioning in speed 1 or intermittent</p>	<p>Module A47 is not powered or is faulty</p>	<ol style="list-style-type: none"> 1. Check DIAGNOSTICS menu of DID. Select FAULT DIAGNOSTIC and ELECTRICAL SYSTEM. The message "No Response ModA47, Active" indicates a power problem on the module. (A CAN network problem would show the same message but doesn't produce these symptoms). 2. Check / reset circuit breaker CB6 3. Check / replace fuse F5 4. Probe gray connector on module to see if it is powered. 5. Use the air release valves near the entrance door and in the front service compartment to lock / unlock the door
<p>Lower windshield wipers not functioning in speed 1 or intermittent</p>	<p>No power on R23</p>	<ol style="list-style-type: none"> 1. Check / replace fuse F18
<p>HVAC condenser fans not functioning in speed 1</p>	<p>Circuit breaker CB7 was manually tripped and not reset</p>	<ol style="list-style-type: none"> 1. Check / reset circuit breaker CB7
<p>HVAC condenser fans not functioning in speed 2</p>	<p>Circuit breaker CB7 was manually tripped and not reset</p>	<ol style="list-style-type: none"> 1. Check / reset circuit breaker CB7
<p>Lower and upper windshield washer not functioning</p>	<p>Module A46 is not powered or is faulty</p>	<ol style="list-style-type: none"> 1. Check DIAGNOSTICS menu of the DID. Select FAULT DIAGNOSTIC and ELECTRICAL SYSTEM. The message "No Response ModA46, Active" indicates a power problem on

Problem/Symptom	Probable Causes	Actions
<p>Upper windshield wiper not functioning</p> <p>Defroster fan is functioning but no heat or cooling available in the driver area</p>		<p>the module. (A CAN network problem would show the same message but doesn't produce these symptoms).</p> <ol style="list-style-type: none"> 2. Check / reset circuit breaker CB1 3. Check / replace fuse F12 4. Probe gray connector on module to see if it is powered.
<p>Low beam headlights and front flasher on left side not functioning</p> <p>Electric horn not functioning</p>	<p>Module A45 is not powered or is faulty</p>	<ol style="list-style-type: none"> 1. Check DIAGNOSTICS menu of the DID. Select FAULT DIAGNOSTIC and ELECTRICAL SYSTEM. The message "No Response ModA45, Active" indicates a power problem on the module. (A CAN network problem would show the same message but doesn't produce these symptoms). 2. Check / reset circuit breaker CB2 3. Check / replace fuse F33 and F34 4. Probe gray connector on module to see if it is powered.
<p>Low beam headlights and flasher on right side not functioning</p>	<p>Module A48 is not powered or is faulty</p>	<ol style="list-style-type: none"> 1. Check DIAGNOSTICS menu of the DID. Select FAULT DIAGNOSTIC and ELECTRICAL SYSTEM. The message "No Response ModA48, Active" indicates a power problem on the module. (A CAN network problem would show the same message but doesn't produce this symptom). 2. Check / reset circuit breaker CB2 3. Check / replace fuse F33 and F34 4. Probe gray connector on module to see if it is powered.
<p>Rear flashers not functioning</p> <p>Stoplights and high-mounted stoplight not functioning</p>	<p>Module A51 is not powered or is faulty</p>	<ol style="list-style-type: none"> 1. Check DIAGNOSTICS menu of the DID. Select FAULT DIAGNOSTIC and ELECTRICAL SYSTEM. The message "No Response ModA51, Active" indicates a power problem on the module. (A CAN network problem would show the same message but doesn't produce this symptom). 2. Check / reset circuit breaker CB2 3. Check / replace fuse F80 4. Probe gray connector on module to see if it is powered.

Section 06: ELECTRICAL

Problem/Symptom	Probable Causes	Actions
<p>Engine is overheating and radiator fan clutch does not engage</p> <p>The A/C compressor clutch does not engage</p>	<p>Module A52 is not powered or is faulty</p>	<ol style="list-style-type: none"> 1. Check DIAGNOSTICS menu of the DID. Select FAULT DIAGNOSTIC and ELECTRICAL SYSTEM. The message "No Response ModA52, Active" indicates a power problem on the module. (A CAN network problem would show the same message but doesn't produce this symptom). 2. Check / reset circuit breaker CB5 3. Check / replace fuse F65 4. Probe gray connector on module to see if it is powered.
<p>Evaporator fan not functioning</p>	<p>Circuit breaker CB3 tripped</p> <p>Module A54 is not powered or is faulty</p>	<ol style="list-style-type: none"> 1. Check / reset circuit breaker CB3 2. Check DIAGNOSTICS menu of the DID. Select FAULT DIAGNOSTIC and ELECTRICAL SYSTEM. The message "No Response ModA54, Active" indicates a power problem on the module. (A CAN network problem would show the same message but doesn't produce this symptom). 3. Check / reset circuit breaker CB5 4. Check / replace fuse F67 , F68 5. Probe gray connector on module to see if it is powered.
<p>HVAC condenser fans not functioning in speed 1</p>	<p>Module A54 is not powered or is faulty</p>	<ol style="list-style-type: none"> 1. Check DIAGNOSTICS menu of the message center display (MCD). Select FAULT DIAGNOSTIC and ELECTRICAL SYSTEM. The message "No Response ModA54, Active" indicates a power problem on the module. (A CAN network problem would show the same message but doesn't produce this symptom). 2. Check / reset circuit breaker CB5 3. Check / replace fuse F67 , F68 4. Probe gray connector on module to see if it is powered.
<p>Sound system not functioning</p>	<p>Circuit breaker CB4 or CB11 was manually tripped and not reset</p>	<ol style="list-style-type: none"> 1. Check / reset circuit breaker CB4 or CB11
<p>Fire alarm telltale light and audible alarm always ON and there is no fire or high temperature in the engine compartment</p>	<p>Short-circuited fire sensor or defective sensor</p>	<ol style="list-style-type: none"> 1. Prior to start the vehicle, cycle the ignition key to the ON position, OFF position and then ON position again and then start the vehicle. This will deactivate the fire alarm function. This has to be repeated each time the vehicle is re-started

Problem/Symptom	Probable Causes	Actions
The vehicle is parked and the electrical horn is activated to indicate a fire in the engine compartment but there is no fire	Short-circuited fire sensor or defective sensor	1. Cycle the ignition key between the ON and OFF position twice within 3 seconds. This will deactivate the fire alarm function. This has to be repeated each time the vehicle is parked
A single light, a group of LED lights or another function of the vehicle is not functioning	The multiplex outputs are protected in current by an internal "soft-fuse". When an output is shorted, it turns OFF and stays OFF until the "soft-fuse" is reset	1. Turn the ignition key to the OFF position and turn to the ON position again. This resets all "soft-fuses"
No backlighting in the instrument cluster	Circuit breaker CB10 is tripped or fuse F29 blown	Check / reset circuit breaker CB10 Check / replace fuse F29
The radiator fan clutch does not function and the engine is overheating		<p>You can manually engage the radiator fan clutch speed 1 or speed 2.</p> <ol style="list-style-type: none"> 1. On the Driver Information Display, select DIAGNOSTICS menu. Select VEHICLE TESTS submenu and then ACTIVATE RADIATOR FAN SPEED 1 or ACTIVATE RADIATOR FAN SPEED 2. 2. The DID status line will show TEST to confirm the forced activation of the radiator fan clutch. To cancel, turn the ignition switch to the OFF position or press ESCAPE button, select STOP TEST submenu and then press ENTER button twice. TEST will disappear from the DID status line. <p>If the fan clutch does not engage using this procedure then the clutch is faulty or the wiring between the multiplex module and the clutch is faulty. Mechanically lock the fan clutch as described in section 05: COOLING SYSTEM of the maintenance manual.</p>

5.9 ESSENTIAL FUNCTIONS TO OPERATE THE VEHICLE

Even with a defective MCM (Master Chassis Module) or a CAN network problem, essential base functions are maintained to rear start the vehicle from the engine compartment and drive in a secure manner.

However, many secondary functions are lost. In this case, the following directives must be followed.

- Never connect a battery charger when the ignition is at the ON position on a vehicle with a CAN defective or certain functions will start up by themselves.
- Disconnect the charger before starting the vehicle, if not the default functions will not activate.
- If the default mode does not activate, try to turn the ignition OFF while ensuring that no

Section 06: ELECTRICAL

charger is connected and then restart the vehicle.

5.9.1 Available Functions

- Startup: Turn on the ignition in the driver's area and rear start the vehicle from the engine compartment,
- Opening the door: Functions normally,
- Closing the door: Manually pull on the door and it will lock automatically,
- Windshield wipers: Wipers functions at 1st speed only,
- Windshield washer fluid: Lower windshield washer only,
- Headlights: Low beams only,
- Directional signals: Rear and front only,
- Stoplights: 2 upper stoplights + high-mounted stoplight are functional,
- HVAC: Functional with set point fixed at 70°F (22°C), evaporator and condenser fixed at speed 1, defroster fixed at speed 4.

5.10 LOWER PRIORITY MODULES FOR BREAKDOWN SERVICE

Modules A43 (IO-A) and A44 (IO-B) affect lower priority functions. These modules can therefore be used as spare parts for breakdown service while on the road.

Functions lost if A43 is removed and used as spare part:

- High beams,
- Ability to turn on the parking lights only,
- « Watch your step » sign,
- Driver's area lighting,
- Tag axle activation,
- Courtesy lights.

Functions lost if A44 is removed and used as spare part:

- Fresh air damper mix trap control,
- Driver's area and entrance overhead light,
- Front clearance lights.

5.11 MULTIPLEX MODULES

5.11.1 MCM

The MCM plays the role of interface between the engine ECM, the transmission TCM, the telltale panel module and other IO-A, IO-B modules. When a multiplex module is being replaced, the MCM will inform the new module of its role and function accordingly to the vehicle options. The MCM also keeps the specific back-up program of the vehicle. So, a specific MCM cannot be removed from a vehicle and installed on another vehicle.

5.11.2 I/O-A

I/O-A modules receive inputs and control outputs. IO-A's are used for all outputs of 1 amp or less.

5.11.3 I/O-B

I/O-B modules receive inputs and control outputs. I/O-B's are used for outputs up to 30 amps.

5.12 MULTIPLEX MODULES REPLACEMENT

I/O-A, I/O-B modules can be replaced and reprogrammed without having to connect a computer to the vehicle. MCM module reprogramming is performed with connection to a computer.

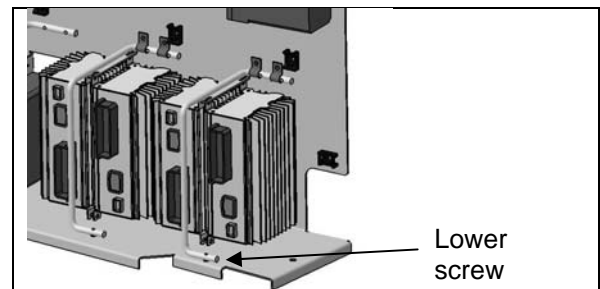

FIGURE 20: IO-B MODULE REMOVAL

5.12.1 Replacing I/O-A Or I/O-B Modules And Initiating Autoprogramming

- Set the ignition key to the ON position and leave it in that position at all time while performing this procedure.
- Inside main power compartment, trip circuit breaker CB6.
- Replace the module (for I/O-B modules, disconnect the green connector first, then the grey one and finish with the black connector). To disconnect the black connector, slide the red latch downwards. Remove the lower

screw that holds the cable attachment rod onto the floor portion of the panel and flip the rod up, this will relieve the I/O-B module, see Fig. 20).

- Reset circuit breaker CB6. This engages the I/O auto programming.
- The DID indicates "MUX AUTOPROGRAMMING I/O MODULE PLEASE WAIT" until the reprogramming is complete unless a higher priority message must be displayed. If this is the case, press ESCape button repeatedly to acknowledge the higher priority messages.
- Check the DIAGNOSTICS menu of the DID. Select FAULT DIAGNOSTICS and ELECTRICAL SYSTEM. Verify the fault message to be certain the module is reprogrammed. If the module is not reprogrammed, the message « Axx Not Responding » appears where Axx is the module number (Ex: A41, A42...etc).

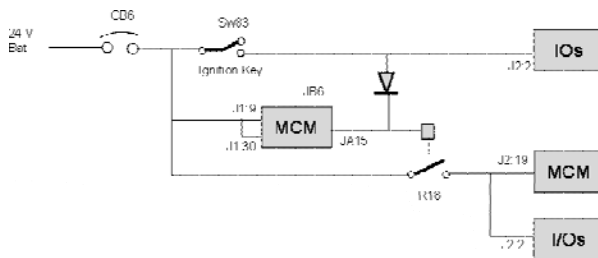

JB6 is a wake-up pin

JA15 output remains active for 15 minutes after JB6 is inactive

To initiate reprogramming:

- Switch SW83 (ignition key) closed, providing 24-volt on JB6, I/O modules and R18. All modules get power.
- CB6 is tripped and reset which is forcing MCM reboot.
- When resetting CB6, all modules gets power, MCM goes into Start Mode. I/O modules needing new program will request reprogramming to MCM while in Start Mode.

5.12.2 Replacing The MCM Module

- Set the ignition key to the ON position and leave it in that position at all time while performing this procedure.

- Inside main power compartment, trip circuit breaker CB6.
- Replace the module.
- Reset circuit breaker CB6.
- The vehicle specific program needs to be uploaded in the MCM. A laptop computer equipped with VPG (Vehicle Program Generator) software must be connected to the DB9 (9-pins) connector (identified C226) found in the electrical harness near the MCM. **Please, contact your Prevost Service Representative if a reprogramming is required.**

6 ALTERNATORS

Two 28-volt 120A, self-regulated, belt driven, air-cooled HD 10 BOSCH alternators are used in the 24 volt electrical system.

If the alternators needed to be removed, reinstall as follows.

1. If necessary, tighten 4 screws fixing alternator support assembly onto engine (item 5). Use Loctite 243 blue (680038) onto the threads.
2. Tighten screws fixing alternator belt tensioner support assembly onto engine (item 1 & 2). Use Loctite 243 blue onto the threads.
3. Also tighten the screw fixing belt tensioner onto alternators support assembly (item 6). Use Loctite 243 blue (680038) onto the threads.

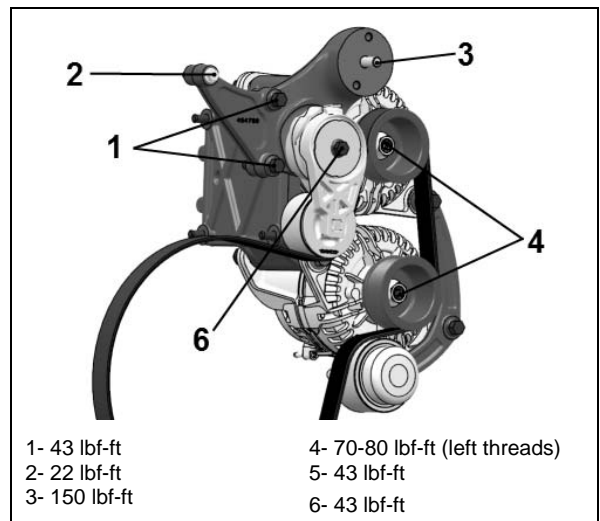

FIGURE 21: ALTERNATORS DRIVE BELT

Section 06: ELECTRICAL

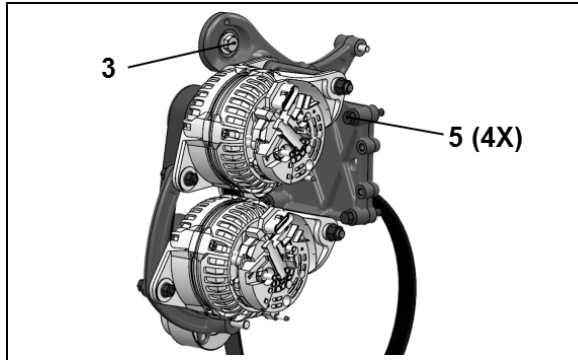
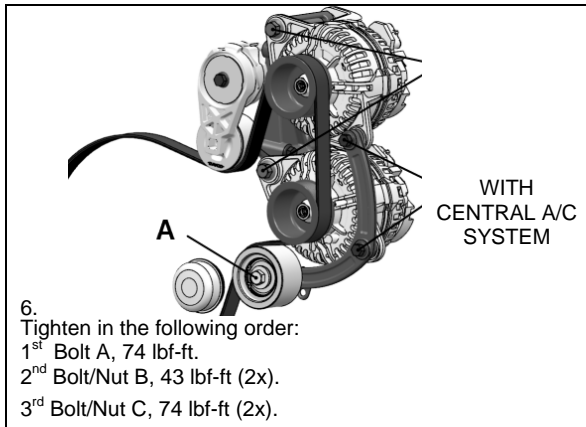

FIGURE 22: ALTERNATORS AND ACCESSORIES MOUNTING TORQUES (H3 COACH SHOWN)

4. If applicable, mount the A/C compressor idler pulley onto alternator belt tensioner support (item 3). Use some Loctite 243 blue (680038) onto the threads.
5. Fix lower and upper alternators loosely to alternators support assembly (bolts 5). Also, mount arched support loosely onto alternators. If applicable, install stone guard below lower alternator.



6. Tighten in the following order:
 - 1st Bolt A, 74 lbf-ft.
 - 2nd Bolt/Nut B, 43 lbf-ft (2x).
 - 3rd Bolt/Nut C, 74 lbf-ft (2x).

Figure 23: alternator mounting, tightening sequence – central a/c system

7. In order to assure installation, it is important to tighten the alternator mounting bolts in proper sequence. (fig.23 & fig.24).
8. Mount pulley onto alternator.
9. Install alternator belt.

NOTE

Final tightening of the pulleys can be performed once the belt is installed. This will help keep the pulley from turning when tightening.

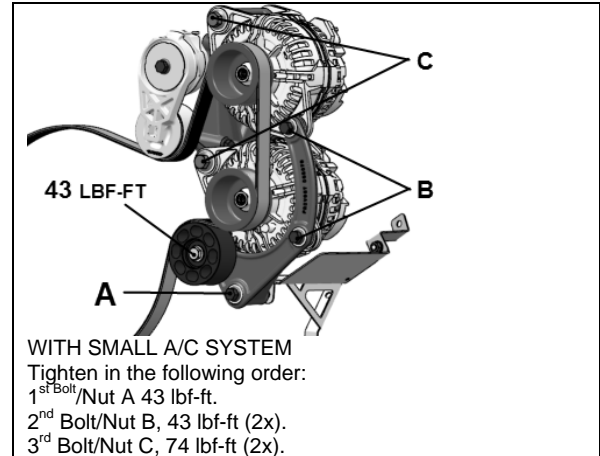

- WITH SMALL A/C SYSTEM**
Tighten in the following order:
- 1st Bolt/Nut A 43 lbf-ft.
 - 2nd Bolt/Nut B, 43 lbf-ft (2x).
 - 3rd Bolt/Nut C, 74 lbf-ft (2x).

FIGURE 24: ALTERNATOR MOUNTING, TIGHTENING SEQUENCE – SMALL A/C SYSTEM

6.1 ALTERNATOR BRUSH REPLACEMENT

1. Disconnect the electrical harnesses and remove the alternator.
2. Remove the cover located on the rear side of the alternator.
3. Dismount the brush holder and voltage regulator assembly. To do so, remove the 3 screws indicated with arrows.

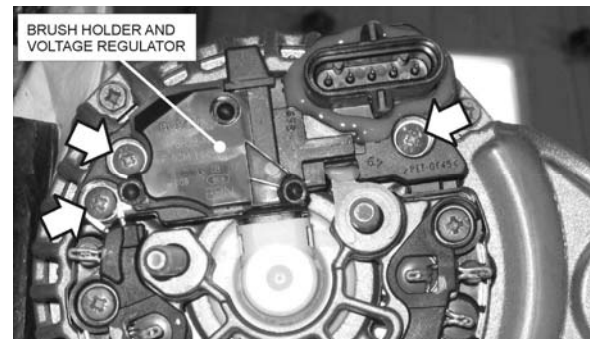

FIGURE 25: BOSCH HD10 BRUSH HOLDER MOUNTING SCREWS

4. Install the new brush holder and tighten the screws.
5. Reinstall the cover. Tighten screw and nuts.
6. Reinstall the alternator loosely.
7. Connect ground harness and (+) positive cable on the lower alternator as shown (figure 26).
10. In order to assure proper installation, it is important to tighten the alternator mounting bolts according to proper sequence (see previous section).

- On the upper alternator, connect the power harness onto the adaptor. Tighten nut to 10 lbf-ft.

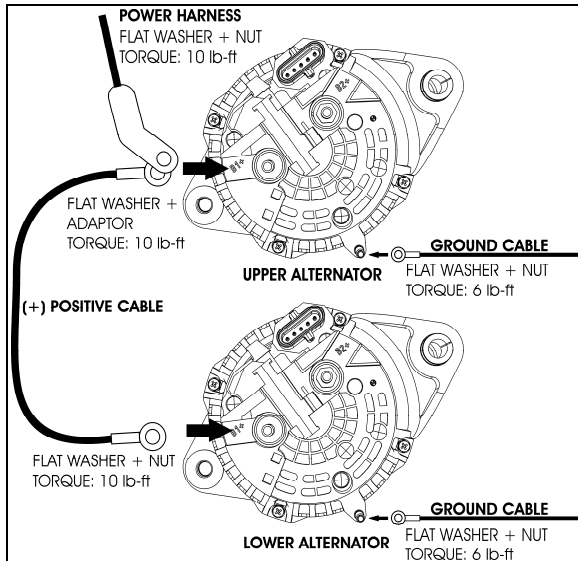



FIGURE 26: TWIN BOSCH HD10 CONNECTIONS

- Connect the 5-pin connector on both alternators.
- Apply protective rubber coating (p/n 684013) or similar product on the stud terminals, washers and nuts.



MAINTENANCE

Commuter application

Check Bosch HD10 alternator brushes and replace if necessary after every 50 000 miles (80 000 km).

Other applications

Check Bosch HD10 alternator brushes after every 100 000 miles (160 000 km) and replace if necessary.

6.2 IDENTIFYING THE DEFECTIVE ALTERNATOR

When an alternator is not charging, the instrument cluster ALTERNATOR telltale will illuminate.



ALTERNATOR
telltale

To identify which alternator is defective (1=lower alternator, 2=upper alternator), proceed as follows:

- On the DID (Driver Information Display), select DIAGNOSTICS menu.

- Select VIEW ACTIVE FAULTS and then ELECTRICAL SYSTEM.
- The active electrical system faults will appear. Scroll through the active faults. You will find one of the following messages:

MID (188) ELECTRICAL SYSTEM
PSID 34 ALTERNATOR 1
FMI (5) OPEN CIRCUIT

MID (188) ELECTRICAL SYSTEM
PSID 35 ALTERNATOR 2
FMI (5) OPEN CIRCUIT

6.3 ALTERNATOR DRIVE BELT

Removal

- Insert a 3/4" socket drive into the automatic belt tensioner opening.
- Twist the tensioning arm to slacken belt.
- Remove belt.

NOTE

Belts specifications may vary. For proper belt selection, always consult your vehicle Coach Final Record.

Installation

Installation of the alternator drive belt is the reverse of removal.

6.4 ADJUSTMENT

Correct belt tension is required to maximize belt life. The tensioning arm maintains proper belt tension, no adjustment is required.



MAINTENANCE

Check for wear and proper tension every 6,250 miles (10 000 km) or twice a year, whichever comes first.

Section 06: ELECTRICAL

7 BATTERY EQUALIZER

Vanner "Vann-Guard 70-Series" Battery equalizer is located beside the batteries in battery compartment. Battery Equalizer Owner's Manual (100 amps) is annexed at the end of this section.

For vehicles with PRIME energy management system, a Vanner "Vann-Bus 80 Series" 100amp Battery equalizer with Smart Monitor is installed beside the batteries in the battery compartment. Owner's Manual is annexed at the end of this section.

8 STARTER

Refer to Mitsubishi Electric Corporation (MELCO) Service bulletin ME003-P annexed at the end of this section for information and maintenance instruction on MELCO 105P70 starter.



CAUTION

Do not engage starter for more than 15 seconds at a time. If engine does not start within 15 seconds, release ignition key and let starter cool for one minute before attempting to restart.

9 ENGINE BLOCK HEATER

The vehicle may be equipped with an engine immersion-type electric block heater to assist cold weather starting. The heater male electric plug is located on the engine compartment R.H. side door (fig. 23). To use it, connect the female plug of an electrical extension cord to the heater plug.

Some converted vehicles may have the heater connected to the coach AC power system. The extension cord must be plugged into a 110-120 V AC power source only. The engine block heater should be used whenever the vehicle is parked for an extended period of time in cold weather and a suitable power source is available.

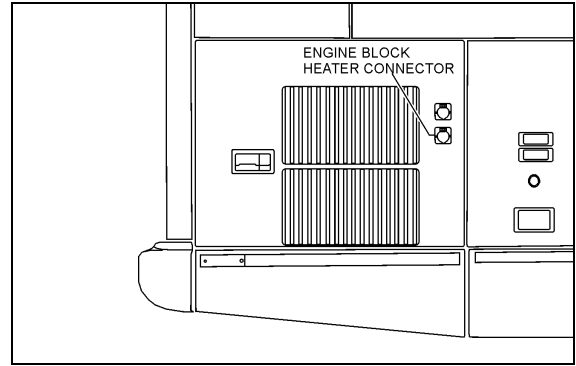

FIGURE 27: ENGINE BLOCK HEATER PLUG LOCATION

9.1 MAINTENANCE

This heater is non-serviceable except for the cord, and if faulty, must be replaced as a unit.

10 EXTERIOR LIGHTING

The circuit for exterior lights, as well as their control switches, relays and circuit breakers are shown on the applicable wiring diagrams. Wiring diagrams are located in the technical publication box.

10.1 HEADLIGHTS

Inner headlights are used for high beam and daytime running light while outer headlights are used for low beam. The inner or outer lamp uses the same single filament halogen bulb part number.

NOTE

If vehicle is equipped with optional Xenon headlights, refer to paragraph 6.1.6.

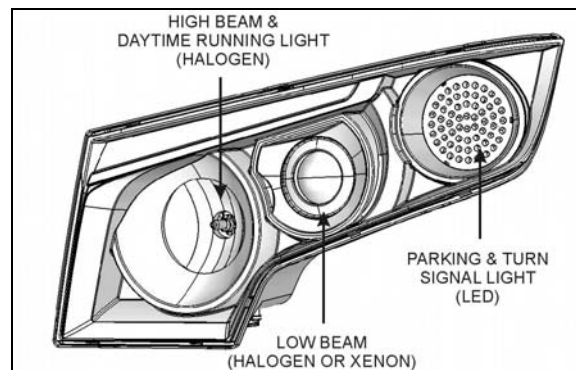

FIGURE 28: HEADLIGHT ASSEMBLY

06713

10.1.1 Headlight Beam Toggle Switch

The multifunction lever located on the steering column is used to select proper lighting. High beams or low beams can be selected by pulling the lever rearward. A high beam indicator on the

central dashboard panel is illuminated when the high beam circuit is energized.

NOTE

Pulling the lever rearward while the lights are off will flash the headlights.

10.1.2 Maintenance

Clean headlights with soap and water and a good glass cleaner whenever dirty. For maximum illumination, headlight connections must be coated with a dielectric grease to prevent oxidation and proper voltage must be maintained. Low battery voltage, loose or dirty contacts in wiring system and poor ground contribute to a decrease in voltage. Check wiring and connections regularly and keep battery properly charged.

10.1.3 Replacing headlight bulbs

The following illustrations show how to gain access to the bulbs. When replacing a bulb, make sure the ignition switch and light switch are off.



CAUTION

- To prevent burning yourself, do not replace the light bulbs while they are hot.
- Halogen bulbs have pressurized gas inside and require special handling. They can burst or shatter if scratched or dropped. Hold a bulb only by its plastic case. Do not touch the glass part of a bulb with bare hands.

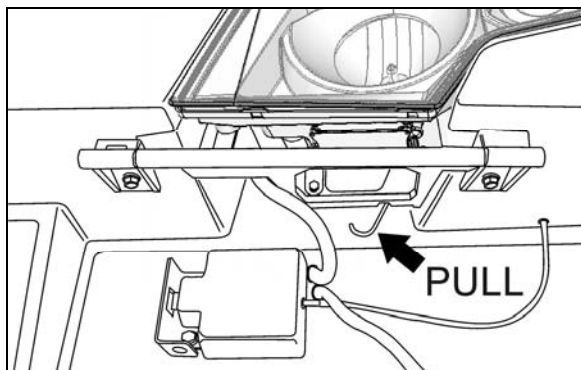

FIGURE 29: ROCKING THE HEADLIGHT ASSEMBLY 06714

1. First, make sure the ignition switch and light switch are off.
2. Pull on the reclining bumper opening handle located inside the front electrical and service compartment.

3. Pull on the rod shown on figure 29 to pivot the headlight assembly.
4. Unscrew the cap to gain access to the bulb connector.
5. HALOGEN: turn the bulb base counterclockwise. XENON: Unscrew the Phillips head screws indicated by arrows, pull the retainer and bulb out (fig.30).

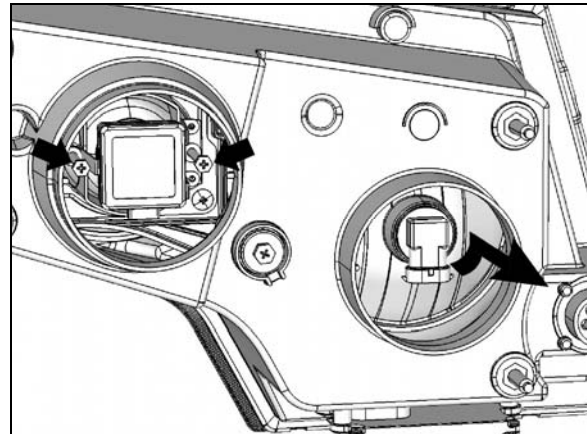

FIGURE 30: HEADLIGHT ASSEMBLY REAR VIEW 06715



CAUTION

During this step, avoid contacting the bulb with the fingers not to alter the bulb life.

6. Unplug the connector while depressing the lock release when applicable.
7. Replace bulb, connect to harness and install into mounting hole.

Aiming is not necessary after replacing the bulb. When aiming is necessary, refer to paragraph "HEADLIGHT AIMING".

10.1.4 Replacing Front Turn Signal LED module

The front turn signal is part of the front headlight assembly. The turn signal is a sealed unit (LED) located on each front corner and should be replaced as an assembly. Turn signal is visible from both front and side.

Removal and Replacement

1. Rotate the cap to gain access to the LED module.
2. Disconnect the electrical harness connector from the LED module.

Section 06: ELECTRICAL

3. Unscrew the 3 mounting fasteners and replace LED module.
4. Install wiring connector on back of new turn signal module.

10.1.5 Optional Xenon Headlamp (Low Beam)

The outer lamps of each headlight assembly may be equipped with the optional Xenon lamps. These lamps improve visibility and provide better lifespan.

 CAUTION
To avoid breaking the bulb, make sure the socket is in proper position against the stop.

 CAUTION
Never connect a voltmeter or V.O.M. to measure bulb voltage as instrument will be destroyed.

NOTE
<i>Do not disrupt headlight adjustment screws.</i>

When switching on the Xenon headlamp using the rocker switch, a short-circuit test is performed.

Current is detected in the lamp circuit before the ignition time and ignition prevented. Connection of the "hot" lamp to the body mass also prevents ignition. In both cases, the system is cut off within < 0.2 s and can only be restarted via the rocker switch.

In general, the maximum ignition time is < 0.2 s, which period is followed by cutoff. This would happen if a lamp was defected.

Lamp missing: system is cut off after < 0.2 s.

If lamp components or cables are damaged by force (accident) so that contact with hazardous parts is possible, the current in these lines is earthed by the vehicle body and - as with a defective household appliance - switched off when 30mA are reached within < 0.2 s. the cutoff time is shortened by a more powerful defect current.

To protect the ballast, a counter in the electronic safety system ensures that a defective lamp can only be switched off 7 times consecutively after a successful ignition, after which the device is cut off. This prevents flutter and flashing. This counter is put out of action when the lamp cutoff

time repetition interval is longer than 1.3 s so that temporary non-defect disturbances that result in immediate invisible re-ignition do not cause lamp cutoff.

A warning notice on the lamp plug makes you aware of the fact that the lamp is operated in this system on a higher voltage (you should therefore switch off the lamp before working on this part).

After taking out the lamp, the contact pins are in a practically idle stat (< 34 Volt) after < 0.5 seconds so that there is no immediate danger of electric shock even if the warning is disregarded.

With this safety concept there is no danger to check the ballast with a new bulb. There is a very high probability that the ballast is OK if the ballast can ignite the bulb.

One simple test to check the ballast would be to measure the Nominal current of 1.58A after one minute for the 24V ballast.

10.1.6 Aiming headlights

Headlights must be properly aimed to provide maximum allowable road illumination. Aiming can be performed without opening headlight assembly. Vertical aiming of each module is provided by one adjusting screw that pivots the entire module in the housing for proper alignment (Fig. 32). There is no adjustment for focus since the module is set for proper focus during manufacturing assembly.

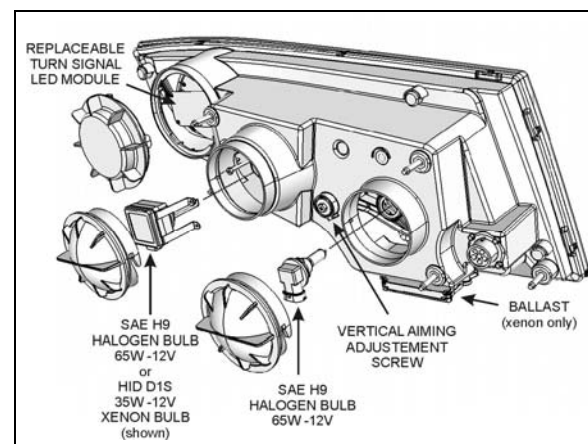

FIGURE 31: HEADLIGHT ASSEMBLY

06716

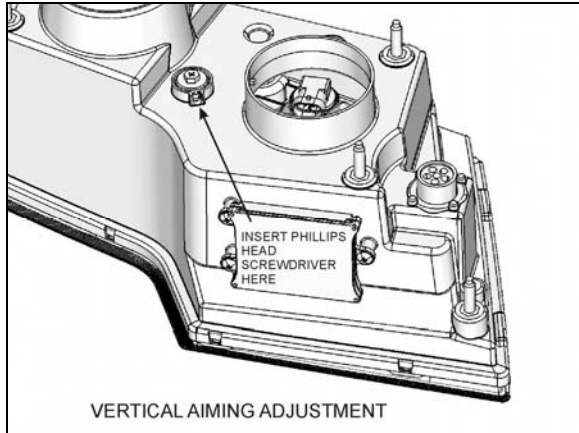

FIGURE 32: VERTICAL AIMING

06717

2. Position the new light assembly and install the "Phillips" screws.

10.2 STOP, TAIL, DIRECTIONAL, BACK-UP, AND HAZARD WARNING LIGHTS

A combination stoplight, taillight, directional signal light and back-up light assembly is mounted at the rear, on each side of the vehicle. Furthermore, when braking, a high-mounted stoplight will illuminate simultaneously with the stoplights on the sides for increased safety.

The stop and tail lights are combined in the same 6-LED lamp. The directional signal and license plate lights consist of individual LED lights mounted on the engine rear door, and each light is serviced individually as a complete unit. The back-up light sealed unit uses a regular tungsten bulb.

The hazard warning flashing system uses the front, side and rear directional lights simultaneously. This system is energized by a switch on the L.H. dashboard.

10.2.1 Lamp Removal And Replacement

1. Open engine compartment rear door.
2. Unscrew the lamp support retaining screws (2), and then from the outside, remove the lamp and its support.
3. From the outside, install the new lamp with its support then fasten the retaining screws.

10.2.2 High-Mounted Stop Light Removal And Replacement

This vehicle is equipped with a high-mounted stop light (LED). This light is a sealed unit and should be replaced as an assembly in accordance with the following procedure:

1. Unscrew both "Phillips" light screws, and then remove the light assembly.

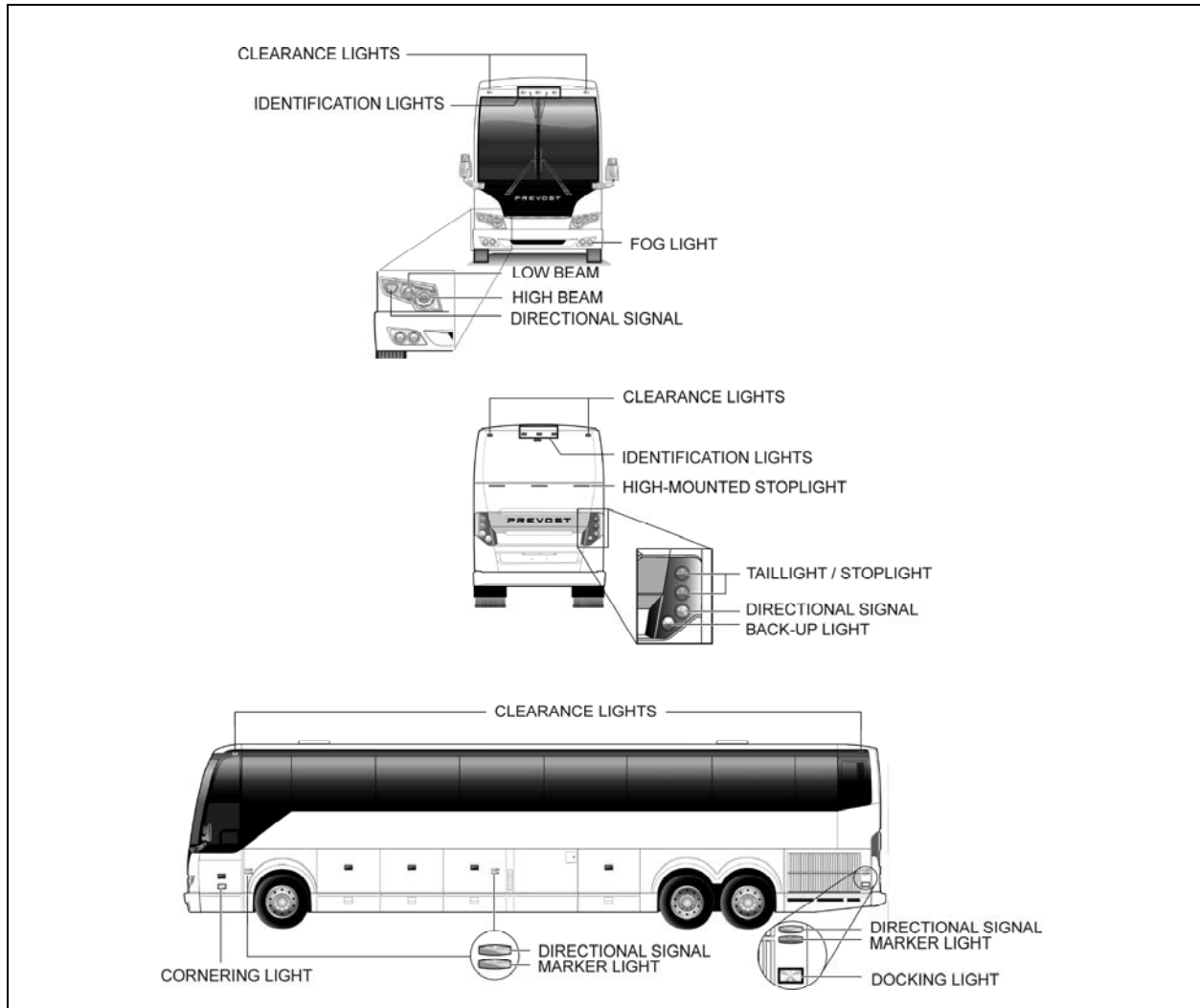

FIGURE 33: VARIOUS LIGHTS LOCATION

18588_4

10.3 LICENCE PLATE LIGHT

Two LED units are mounted above the rear license plate(s) of vehicle. In case of burn out, the LED unit must be changed according to the following procedure.

1. Pry out the rubber seal with a small screwdriver. Pull on the LED unit and disconnect it.
2. Reconnect new LED unit, place rubber seal, and press on it until it is seated in position.

10.4 CLEARANCE, IDENTIFICATION AND MARKER LIGHTS

The vehicle is equipped with marker, identification and clearance lights (LED). The clearance lights are mounted at each corner near the top and the identification lights are in the upper center of rear and front

sections. The rear clearance and identification lights are red and the front ones are amber.

The amber marker lights are mounted along the sides of vehicle.

10.4.1 Marker Light Removal And Replacement

The side marker light is a sealed unit (LED) and should be replaced as an assembly in accordance with the following procedure:

1. Unscrew both "Phillips" light screws, disconnect and remove the light assembly.
2. Connect and position the new light assembly and install the "Phillips" screws.

10.4.2 Clearance And Identification Light Removal And Replacement

The clearance and identification lights are sealed units (LED) and should be replaced as an assembly in accordance with the following procedure:

1. Unscrew both “Phillips” light screws, disconnect and remove the light assembly.
2. Connect and position the new light assembly, then install the “Phillips” screws.

10.5 DOCKING AND CORNERING LIGHTS

This vehicle is provided with two halogen sealed-beam units that serve as cornering lights. They are mounted on the vehicle as follows: one is mounted on the front L.H. side service compartment door, while the other is located between the front wheel and the entrance door on the R.H. side. The main function of these lights is to increase lateral visibility when turning a corner. These lights are energized simultaneously with the directional lights. On the V.I.P. model, a dashboard-mounted rocker switch may be actuated to cancel this system in special situations.

Two additional halogen sealed-beam units are installed on rear electrical compartment door (R.H.) and radiator door. These lights are used as docking lights and both will illuminate automatically when reverse range is selected to facilitate back-up or docking procedure.

On the V.I.P. model, these lights do not operate automatically when the reverse range is selected, but by means of a dashboard-mounted rocker switch. When actuated, the docking as well as the cornering lights illuminate. Furthermore, a “*Low docking*” switch, also located on dashboard, allows the use of the docking and cornering lights at a lower intensity when the docking switch is actuated.

10.5.1 Lamp Removal And Replacement

Both docking and cornering sealed-beam units can be changed in accordance with the following procedure:

1. Remove the two “Phillips” screws attaching the retaining ring.
2. Disconnect the light unit connection.
3. Remove the lamp.
4. Position new lamp.
5. Connect and position the light unit.
6. Finally, install the retaining ring and screw.

10.6 FOG LIGHTS

Optional halogen fog lights can be mounted on this vehicle to give the driver better visibility in foggy weather, or to improve the range of vision just ahead of the coach.

10.6.1 Bulb Removal And Replacement

1. Pull on the release handle located in the front electrical and service compartment, near the door lower hinge. The bumper will lower gradually.

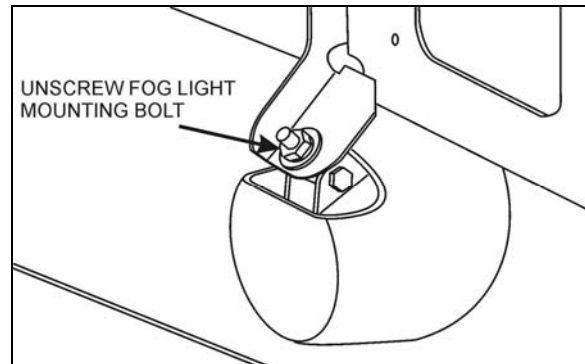

FIGURE 34: FOG LIGHT MOUNTING BOLT

2. From bumper inner side, unscrew the nut fixing the fog light and remove the entire fog light assembly from the bumper.
3. Unscrew the outer ring. Disconnect the light unit connection and remove the bulb.

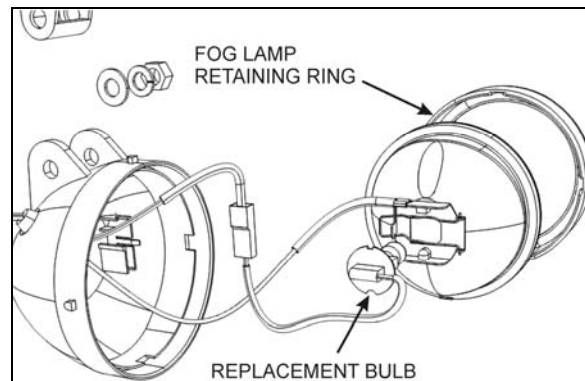

FIGURE 35: FOG LIGHT EXPLODED VIEW



CAUTION

During this step, avoid contacting the bulb with your fingers. This could alter the bulb life.

4. Install the new bulb, reconnect the light unit and replace in its proper position.
5. Reinstall the outer ring, then return the fog light assembly to its proper location.

Section 06: ELECTRICAL

6. Fasten the fog light mounting nut and securely close the bumper.

11 INTERIOR LIGHTING EQUIPEMENT

11.1 CONTROL PANEL LIGHTING

The instrument gauges and switches mounted on all control panels are energized whenever the exterior light switch is pushed to the first position. A control dimmer located on the dashboard is used to vary the brightness of the panel gauges, switches and indicator lights.

The gauge lights, panel lights, switch lights and indicator lights have a different bulb arrangement. Thus, the procedure to change a defective bulb can vary according to the application.

11.1.1 Switch Lighting

1. Slightly pull the switch with a defective LED away from the control panel.
2. Disconnect the electric cable from the switch.
3. To install a new switch, reverse the procedure (fig.36).

NOTE

Switches are lighted by the use of LED. When lighting on a switch fails, replace defective switch as a unit.

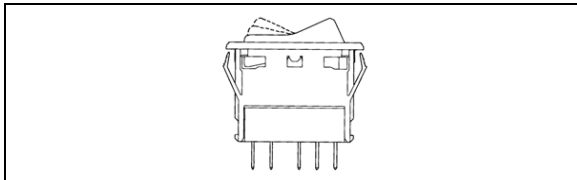

FIGURE 36: SWITCH

11.1.2 Telltale Light Replacement

Telltale module is non-serviceable and must be replaced as a unit.

1. Unscrew and remove the top dashboard panel.
2. Remove the telltale back wire electric connectors.
3. Unscrew and remove the telltale module.
4. To replace the telltale module, reverse the procedure.

11.1.3 Gauge Light Bulb Replacement

1. For any gauge light bulb replacement, the dashboard panel must be removed in order to have access to the rear of gauges.
2. Remove bulb socket from the gauge, turn the defective bulb counterclockwise and pull it out of the gauge.
3. Push a new bulb and socket ASM and turn clockwise to lock in place.
4. Replace the rear dashboard housing.

11.2 STEPWELL LIGHTS

11.2.1 Coach Entrance

The stepwell lights are illuminated when the door opening system is activated (fig.37).

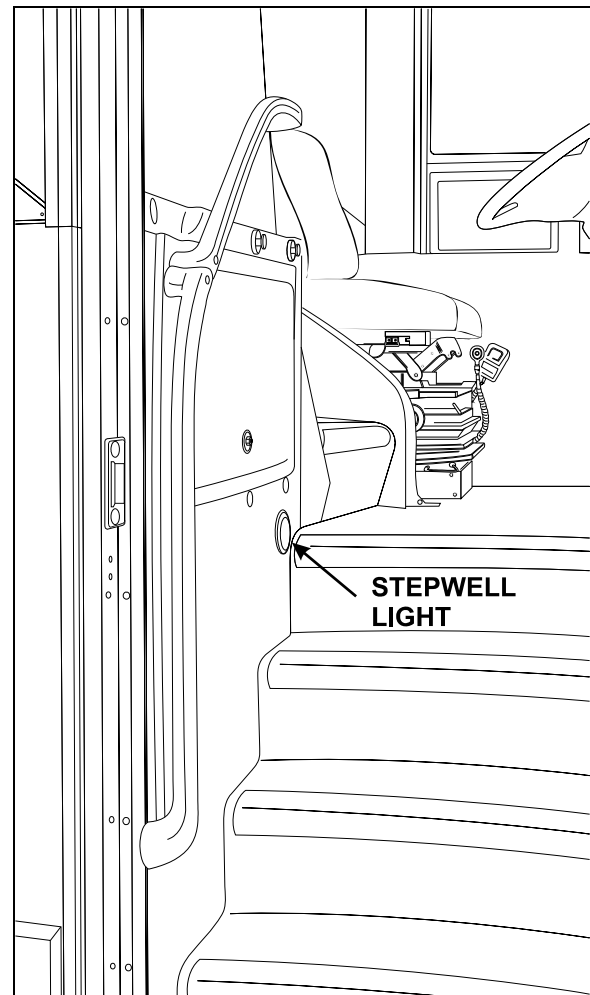

FIGURE 37: COACH ENTRANCE STEPWELL

06492

- Light Removal and Replacement
1. Unsnap the lamp outer ring with a flat head screwdriver and remove it.

2. Unfasten the three fixing screws, remove and disconnect LED light assembly.
3. Connect and install the new LED assembly in position.
4. Fasten the three fixing screws and replace the lamp outer ring by snapping it back in place.

11.2.2 VIP Entrance

The stepwell light is illuminated when the door opening system is activated (fig.38).

11.2.3 Bulb Removal And Replacement

Proceed as follows to replace defective bulb:

1. Unscrew the two Phillips-head screws retaining the lens to the wall, and remove it.
2. With the light lens removed, pull bulb from the lamp while applying lateral pressure.
3. Install the new bulb into the lamp.
4. Position the light lens and install it.

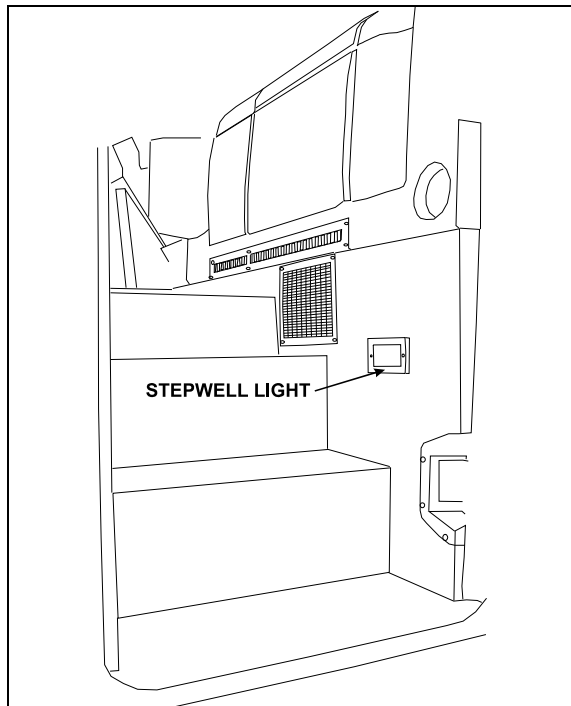

FIGURE 38: VIP ENTRANCE STEPWELL 06507

11.3 LAVATORY NIGHT-LIGHT

The lavatory night-light is illuminated as soon as the ignition switch is set to the "ON" position.

11.3.1 Bulb Removal And Replacement

Proceed as follows to replace defective bulb:

1. Unscrew the two Phillips-head screws retaining the lens to the lavatory wall, and remove it.
2. With the light lens removed, pull bulb from the lamp while applying lateral pressure.
3. Install the new bulb into the lamp.
4. Position the light lens and install it.

11.4 DRIVER'S AREA LIGHTS

One halogen ceiling light is installed over the stepwell and another one over the driver's area. These lights are frequently used for nighttime operation when passengers board or leave coach.

11.4.1 Bulb Removal And Replacement

1. Unsnap the lamp with a flat head screwdriver and remove it.
2. Pull the defective bulb out of the socket.
3. Install the new bulb by pushing it in position.
4. Replace the lamp by snapping it back in place.

	<p>CAUTION</p>
<p>Do not touch halogen bulbs with bare hands as natural oils on skin will shorten bulb life span.</p>	

11.5 PASSENGER SECTION LIGHTING

The passenger section of coach is lit by two types of fluorescent tube lamps installed on the parcel racks.

The aisle or indirect lights are located on front of parcel racks, and provide soft, indirect cabin lighting and parcel rack interior lighting. More powerful lighting for general and in-station applications is provided by fluorescent tubes located under the parcel racks, close to the windows. A dual power system is available for this lighting either from the 24-volt vehicle power supply or from a 110-volt outlet supply. In order to save batteries during extended periods of in-station lighting, no current is drawn from the batteries as soon as the 110-volt circuit is connected.

Moreover, adjustable reading lamps are installed under the parcel racks for passenger accommodation.

11.5.1 Fluorescent Tube Replacement

Section 06: ELECTRICAL

- Indirect Fluorescent Light
 1. Open the parcel rack access door, if so equipped, unscrew the two Phillips screws (one each end). Let the hinged cover down.
 2. Remove fluorescent tube from light socket and install a new fluorescent tube.
 3. Lift the hinged cover and replace the two retaining screws (fig. 39).
- Parcel Rack Interior Lighting
 1. Open the parcel rack access door, if so equipped, unscrew the two Phillips screws (one each end). Pull the hinged cover down.
 2. Push on the bulb, turn and then, pull it from the socket.
 3. Install a new bulb.
 4. Lift the hinged cover and replace the two retaining screws.

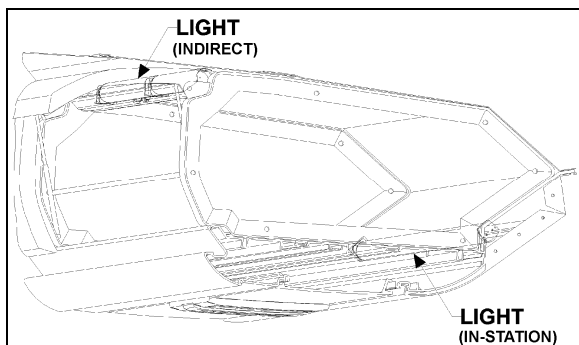

FIGURE 39: PARCEL RACK

06419

11.5.2 Removal And Replacement Of In-Station Fluorescent Tubes

1. Start by pulling out the corner of the lens then delicately peeling it out of its seat.



CAUTION

The lens is fragile. Be very careful when removing and handling.

2. Rotate and pull the fluorescent tube from its sockets.
3. Install a new fluorescent tube, rotating the tube to secure it in the sockets.
4. Replace the screen lens by first inserting one side in the seat, then push the other side in and snap it in place by running it in from one corner to the next.

11.5.3 Removal And Replacement Of Reading Lamp Bulb

1. Engage the tool (#830164) over the lamp and turn one quarter turn counterclockwise. Then, remove the tool slowly.
2. Pull the bulb socket off the reading lamp unit.
3. Push and turn bulb counterclockwise, then pull it out of the socket.
4. Install new bulb in the socket, then push and turn clockwise to lock bulb in position.
5. Push the bulb socket in the reading lamp unit.
6. Position the reading lamp with the tool (#830164), turn one quarter turn clockwise.

11.6 ENGINE COMPARTMENT LIGHTING

Two 24-volts LED module illuminate the engine compartment when the following conditions are met:

1. The engine compartment rear door or curbside door is open.
2. Ignition switch in ON or ACC position.
3. Engine compartment lighting switch on rear engine start panel in ON position.



FIGURE 40: ENGINE COMPARTMENT LED MODULE

11.7 LAVATORY LIGHT

The lavatory halogen lights are installed on ceiling. A microswitch, mounted in the door exterior frame, is activated by the door lock mechanism upon locking to energize the circuit. This switch is readily serviced by removing the two Phillips-head screws securing the mounting plate to the door exterior frame.

Proceed as follows to replace the bulb:

1. Unsnap the lamp with a flat head screwdriver and remove it.
2. Pull the defective bulb out of the socket.
3. Install the new bulb by pushing it in position.

4. Replace the lamp by snapping it back in place.



CAUTION

Do not touch halogen bulbs with bare hands as natural oils on skin will shorten bulb life span.

12 LIGHT BULB DATA

Please, refer to your vehicle Parts Manual for selection of replacement light bulbs.

NOTE

Exterior and interior lights can be 12 volts or 24 volts.

13 SPECIFICATIONS

Battery

Make..... Volvo
Model..... 20359831
Type Maintenance-free
Terminal type Top Stud
Group size..... 31
Volts 12
Load test amperage 290
Reserve capacity (minutes) 195
Cold cranking (in amps)
-At 0°F (-18°C).....950 (each battery)
Maximum dimensions (inches/mm)
-Length (including flange) 13.0/330,2
-Width..... 6.7/169,3
-Height (including top posts) 9.3/237,0
-Approximate weight (lbs/kg) 59/26,7

* *Battery tester cable clamps should be between terminal nuts and lead pads of terminals. If not possible, load value should be 210 amperes.*

AGM Battery

Make..... Volvo
Model..... 21258363
Type Absorbed Glass Mat
Terminal type Top Stud
Group size..... 8A31
Volts 12
Load test amperage 400
Reserve capacity (minutes) 200
Cold cranking (in amps)
-At 0°F (-18°C).....800 (each battery)
Maximum dimensions (inches/mm)
-Length (including flange) 12.93/328
-Width..... 6.7/169
-Height (including top posts) 9.3/237
-Approximate weight (lbs/kg) 61.7/28

Torque specifications

Battery cable to post 10-15 ft-lbf (13-20 N-m)
Battery cover 45-50 ft-lbf (5-6 N-m)

Alternator

Make..... BOSCH
Series HD 10
Amperes 120
Volts 28.4
Output Power 3 Kw
Ground negative
Prevost Number 564119

Battery equalizer

Make..... Vanner
Model..... Vann-Guard 70-Series
Amperes 100 amps

Battery equalizer (with PRIME option)

Make..... Vanner
Model..... Vann-bus 80-Series
Amperes 100 amps

Starter

Make..... Mitsubishi Electric Corporation (MELCO)
Model Number..... M009T82479
Type 105P70
Voltage 24
Prevost Number 510752
No-load test
-Volts 23.5
-Max. current draw 125 amperes
-Min. rpm 3000 rpm

Starter solenoid

Make..... Mitsubishi Electric Corporation (MELCO)
Model Number..... 1115557
Pull In Voltage 16 volts max.