

SECTION 23: ACCESSORIES

CONTENTS

1. AUDIO AND VIDEO EQUIPMENT DESCRIPTION	23-4
1.1 AMP-2000 (HIGH POWER AMPLIFIER).....	23-5
1.1.1 Removal.....	23-6
1.2 AM/FM RADIO.....	23-6
1.2.1 AM/FM Radio Cassette and Disc CD Changer.....	23-6
1.2.2 Removal.....	23-6
1.3 CONTROL HEAD.....	23-6
1.3.1 Removal.....	23-7
1.4 VIDEO CASSETTE PLAYER (VCP).....	23-7
1.4.1 Removal.....	23-7
1.4.2 Installation.....	23-7
1.5 BOOM-TYPE MICROPHONE.....	23-8
1.5.1 Removal.....	23-8
1.5.2 Installation.....	23-8
1.6 HANDHELD PRIORITY MICROPHONE.....	23-8
1.7 RUBBER COATED MICROPHONE.....	23-8
1.8 WIRELESS MICROPHONE.....	23-8
1.9 TV TUNER.....	23-8
1.10 KARAOKE.....	23-9
1.10.1 Karaoke Panasonic Sound System – DVD-A300.....	23-9
1.11 DRIVER'S SPEAKERS.....	23-9
1.12 MONITOR.....	23-9
1.12.1 Removal.....	23-9
1.12.2 Installation.....	23-9
1.13 SCENIC VIEWING SYSTEM.....	23-10
1.14 ROOF ANTENNA INSTALLATION.....	23-10
2. HUBODOMETER	23-10
2.1 DESCRIPTION.....	23-10
2.2 OPERATION.....	23-10
2.3 REMOVAL.....	23-10
2.4 INSTALLATION.....	23-10
3. BACK-UP CAMERA AND MONITOR	23-11
4. COLD STARTING AID (ETHER)	23-11
4.1 PREVENTIVE MAINTENANCE.....	23-11
4.2 TROUBLESHOOTING (IF SYSTEM IS NON-FUNCTIONING).....	23-11
5.3 THERMAL CUTOFF VALVE QUICK TEST.....	23-12
5. DESTINATION SIGN	23-12
5.1 DESCRIPTION.....	23-12
5.2 MAINTENANCE.....	23-13
5.3 DESTINATION SIGN LIGHT REPLACEMENT.....	23-13
5.4 ELECTRIC MOTOR REMOVAL AND INSTALLATION.....	23-13
5.5 SIGN CURTAIN REPAIR.....	23-13
6. LAVATORY	23-13
6.1 DESCRIPTION.....	23-13

Section 23: ACCESSORIES

6.2	MAINTENANCE.....	23-14
6.3	VENTILATION FAN.....	23-14
6.3.1	<i>Description</i>	23-14
6.3.2	<i>Maintenance</i>	23-14
6.3.3	<i>Removal and Installation</i>	23-14
6.4	DOOR LOCK.....	23-15
6.5	LAVATORY LIGHT.....	23-15
6.6	LAVATORY NIGHT-LIGHT.....	23-15
6.7	EMERGENCY BUZZER.....	23-15
6.8	FRESH WATER TANK.....	23-16
6.8.1	<i>Fresh Water Tank Draining</i>	23-16
6.8.2	<i>Fresh Water tank Filling</i>	23-17
6.9	LIQUID SOAP DISPENSER.....	23-17
6.10	FLUSH PUSH-BUTTON.....	23-18
6.10.1	<i>Pneumatic Timer Removal and Installation</i>	23-18
6.10.2	<i>Timer Adjustment</i>	23-18
6.11	FLUSH PUMP.....	23-18
6.11.1	<i>Flush Pump Removal</i>	23-18
6.12	SUMP TANKS.....	23-18
6.12.1	<i>Main Sump Tank Draining</i>	23-18
6.12.2	<i>Main Sump Tank Filling</i>	23-18
6.12.3	<i>Auxiliary sump Tank Draining</i>	23-18
7.	AIR HORN VALVE.....	23-19
7.1	AIR HORN VALVE MAINTENANCE.....	23-19
8.	WINDSHIELD WIPERS AND WASHERS.....	23-19
8.1	GENERAL DESCRIPTION.....	23-19
8.2	WIPER ARM.....	23-20
8.2.1	<i>Wiper Arms Positioning</i>	23-20
8.3	WINDSHIELD WIPER MOTOR.....	23-22
8.3.1	<i>Windshield Wiper Motor Replacement</i>	23-22
8.4	TROUBLESHOOTING.....	23-22
9.	SPECIFICATIONS.....	23-23

ILLUSTRATIONS

FIGURE 1: SOUND SYSTEM JUNCTION PLATE	23-4
FIGURE 2: AMP-2000 AMPLIFIER	23-5
FIGURE 3: PANASONIC CQ-R115SEUC	23-6
FIGURE 4: CONTROL HEAD	23-7
FIGURE 5: INSTALLATION IN PARCEL COMPARTMENT	23-7
FIGURE 6: VIDEO CASSETTE PLAYER.....	23-7
FIGURE 7: BOOM-TYPE MICROPHONE	23-8
FIGURE 8: HANDHELD PRIORITY MICROPHONE	23-8
FIGURE 9: RUBBER COATED MICROPHONE	23-8
FIGURE 10: WIRELESS MICROPHONE	23-8
FIGURE 11: TUNER CONTROLS DESCRIPTION	23-9
FIGURE 12: KARAOKE PANASONIC DVD-A300	23-9
FIGURE 13: MONITOR HOUSING REAR PANEL.....	23-9
FIGURE 14: INSTALLATION IN PARCEL COMPARTMENT	23-10
FIGURE 15: SCENIC VIEW CAMERA	23-10
FIGURE 16: HUBODOMETER	23-10
FIGURE 17: ENGINE	23-11
FIGURE 18: COLD STARTING AID	23-11
FIGURE 19: DESTINATION SIGN – ELECTRICAL	23-12
FIGURE 20: DESTINATION SIGN-ELECTRIC MOTOR	23-13
FIGURE 21; DESTINATION SIGN – ELECTRONIC	23-13
FIGURE 22: LAVATORY	23-14
FIGURE 23: VENTILATION FAN INSTALLATION.....	23-15
FIGURE 24: DOOR LOCK	23-15
FIGURE 25: FUNCTIONING OF LAVATORY	23-16
FIGURE 26: F/W TANK SERVICE VALVES	23-17
FIGURE 27: LIQUID SOAP DISPENSER	23-17
FIGURE 28: AIR HORN VALVE	23-19
FIGURE 29: WINDSHIELD WIPER INSTALLATION	23-19
FIGURE 30: MULTIFUNCTION LEVER.....	23-20
FIGURE 31: WINSHIELD WASHER RESERVOIR	23-20
FIGURE 32: WINDSHIELD WIPER (MOTOR SIDE).....	23-20
FIGURE 33: WINDSHIELD WIPER (DRIVER SIDE).....	23-20
FIGURE 34: WIPER ARMS POSITIONING	23-21
FIGURE 35: DRIVING MECHANISM (DRIVER SIDE).....	23-21
FIGURE 36: DRIVING MECHANISM (MOTOR SIDE).....	23-21

1.1 AMP-2000 (HIGH POWER AMPLIFIER)

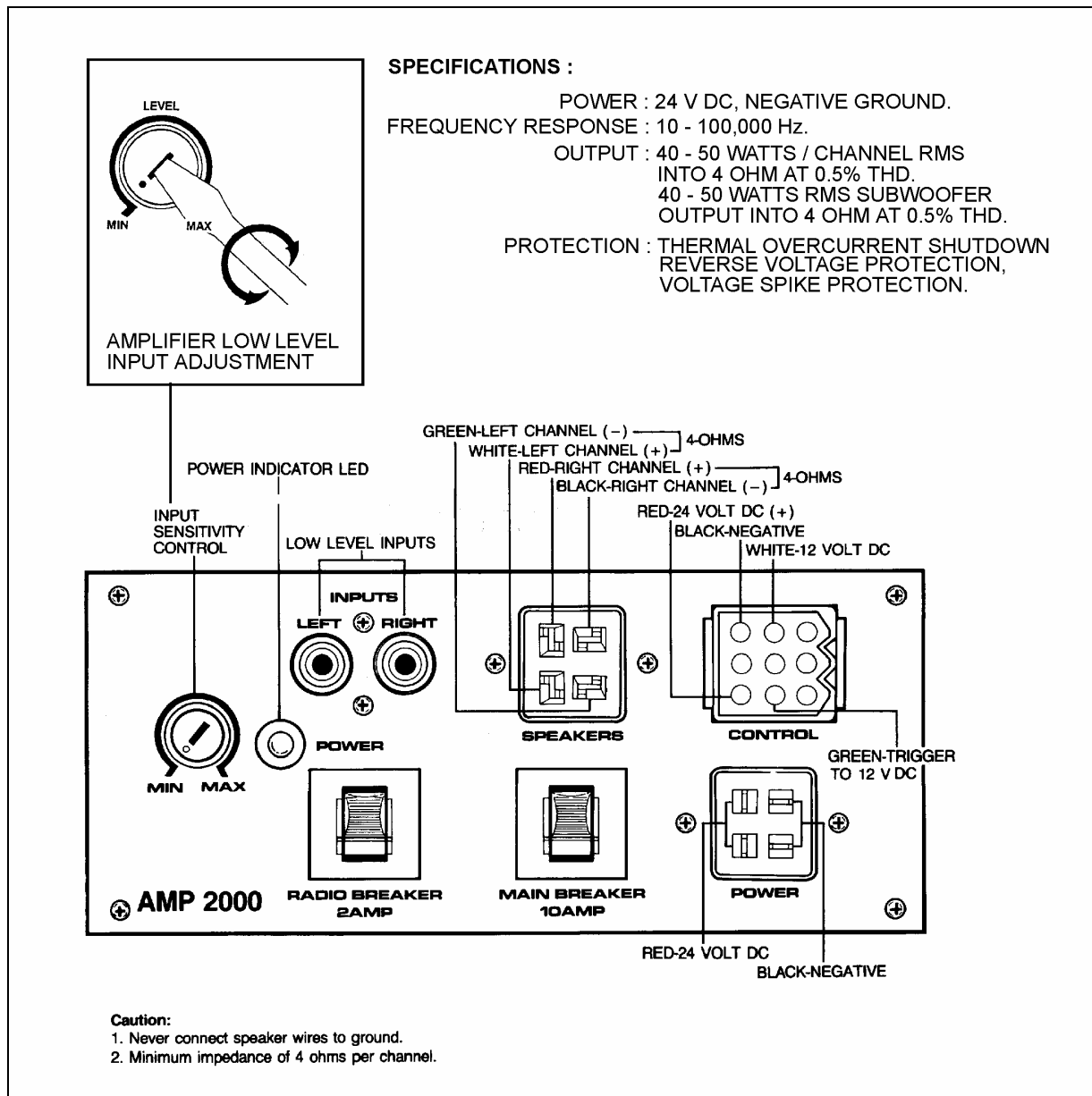

FIGURE 2: AMP-2000 AMPLIFIER

23081

The AMP-2000 brings an added dimension to your stereo equipment and increases the total output of the system. The amplifier will perform with any unit operating in a 24-volt with negative ground electric system. The AMP-2000 is located on the first baggage compartment ceiling. To access, open the first baggage compartment door.

The input sensitivity is adjustable from 100mV to 1V to match the output of the radio or tape deck. Set the volume control on the radio, then adjust the input control on the amplifier for an average listening level. This gives the best balance between radio output and system signal-to-noise ratio (Fig. 2).

Section 23: ACCESSORIES

Caution: The low level input adjustment for this amplifier has been preset according to system specifications.

1.1.1 Removal

Remove the amplifier as follows:

1. Set the battery master switch to the "OFF" position. Refer to Section 6: "Electrical System" for switch location.
2. Remove the sound system junction plate from its location. To perform this step, disconnect wiring connectors, remove cable ties and remove the bolts retaining the sound system junction plate.
3. Remove the four screws retaining the amplifier to its sound system junction plate.
4. Reverse the removal procedure to install the amplifier.

1.2 AM/FM RADIO

1.2.1 AM/FM Radio Cassette and Disc CD Changer

The audio system is composed of an AM/FM radio cassette player "Panasonic, model CQ-R115SEUC (Fig. 3). Also, the vehicle may be equipped with a 6 or 12 disc CD changer and two additional Hi-Fi speakers in the driver's area. A roof antenna as well as different microphone outlets, can be installed as optional equipment.

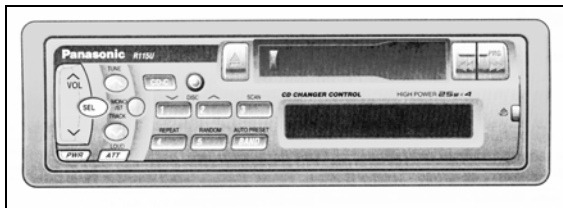

FIGURE 3: PANASONIC CQ-R115SEUC

23218

Note: Before attempting to solve an electrical problem on the sound system, refer to the master wiring diagrams.

Instructions for proper use of the radio are included in the "Panasonic Owner's Manual" which is provided in the technical publication box delivered with the vehicle. The radio is a serviceable component and should only be serviced by a qualified electronics technician. Refer to "Panasonic Service Centers" guide included in the technical publication box.

1.2.2 Removal

To remove the radio from its location, proceed as follows:

1. Place the battery master switch in the "OFF" position.
2. Remove the dashboard panel cover.
3. Disconnect the electrical cable connectors from radio and unfasten back plate securing screw.
4. To separate the radio from its support, push in the dismounting pins included with the Panasonic Owner's Manual.
5. Push the unit through the front instrumentation panel.
5. Install a new unit by reversing the procedure.

1.3 CONTROL HEAD

The system 2000 (Fig. 4) is designed exclusively for coach operations. A complete system will control the following equipment:

- A specially designed 70 watt per channel RMS amplifier, capable of driving up to twenty-six, four ohm speakers.
- Six, custom designed ten-inch color monitors that incorporate a unique anti-theft locking slide mount. This makes installation and removal very easy.
- A specially modified VHS video cassette player that allows the operator convenient control over its functions.

- A digital audio processor that incorporates a centralized system control. The system 2000 microprocessor allows the operator to control up to three audio selections, permitting custom tailoring of each channel's sound quality. There are three microphone inputs for the PUBLIC ADDRESS SYSTEM (PAS), which are switchable between internal and external speakers. The unit contains a separate video section for the VCP that allows the driver to control his own separate audio selections.

Instructions for proper use of the control head are included in the "REI Operator's Manual" which is provided in the technical publication box delivered with the vehicle.

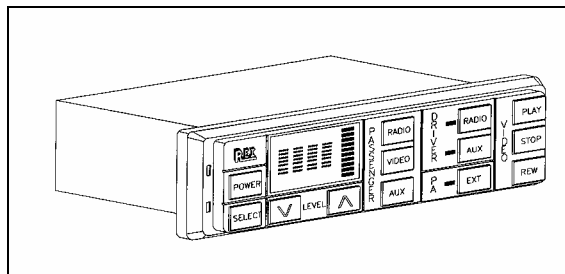

FIGURE 4: CONTROL HEAD

23070

1.3.1 Removal

To remove the control head from its location, proceed as follows:

1. Place the battery master switch in the "OFF" position.
2. Remove the dashboard panel cover.
3. Disconnect the electrical cable connectors from radio and unfasten back plate securing nut.
4. To separate the control head from its support, push in the dismounting pins included with the REI Operator's Manual.
5. Push the unit through the front instrumentation panel.
6. Install a new unit by reversing the procedure.

1.4 VIDEO CASSETTE PLAYER (VCP)

The VCP is located in the first parcel compartment on the driver's side (Fig 5 & 6). Instructions for proper use of the VCP are included in the "Operator's Manual" which is provided in the technical publication box.

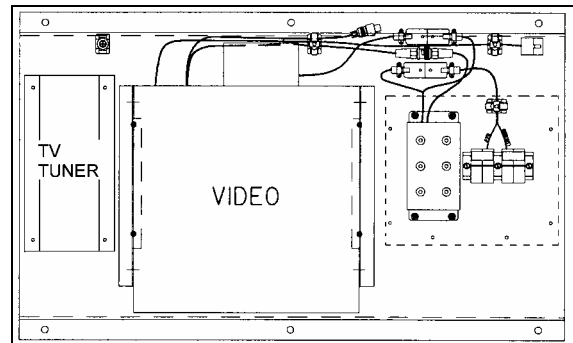

FIGURE 5: INSTALLATION IN PARCEL COMPARTMENT

23223

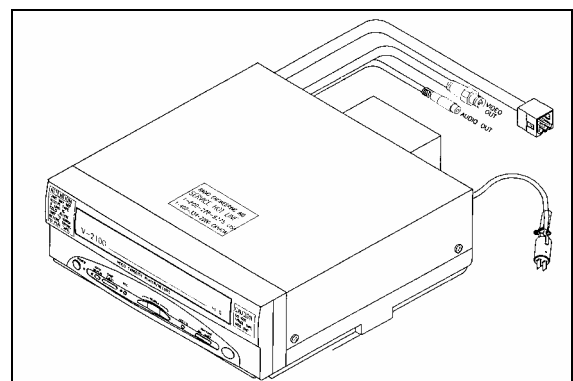

FIGURE 6: VIDEO CASSETTE PLAYER

23075

1.4.1 Removal

1. Place the battery master switch in the "OFF" position.
2. Remove the VCP/VCR mounting locknuts from rubber mounts.
3. Disconnect wiring.
4. Remove VCP/VCR unit from parcel compartment.

1.4.2 Installation

1. Install VCP/VCR unit into parcel compartment aligning rubber mount studs with mounting holes. Insert mount studs through mounting holes.

Section 23: ACCESSORIES

2. Install locknuts on mount studs.
3. Reconnect wiring.
4. Place the battery master switch in the "ON" position.

1.5 BOOM-TYPE MICROPHONE

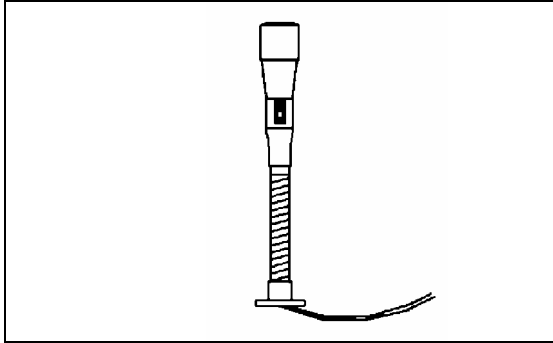

FIGURE 7: BOOM-TYPE MICROPHONE 23083

1.5.1 Removal

1. Place the battery master switch in the "OFF" position.
2. Remove the mounting screws at mounting flange.
3. Disconnect wiring.

1.5.2 Installation

1. Reconnect wiring.
2. Align mounting flange with holes and install screws.
3. Remove spacer block mounting screws.
4. Insert spacer block and install mounting screws.
5. Place the battery master switch in the "ON" position.

1.6 HANDHELD PRIORITY MICROPHONE

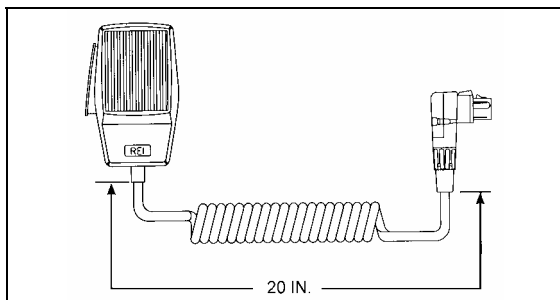

FIGURE 8: HANDHELD PRIORITY MICROPHONE 23216

1.7 RUBBER COATED MICROPHONE c/w 10 Feet cord and connector

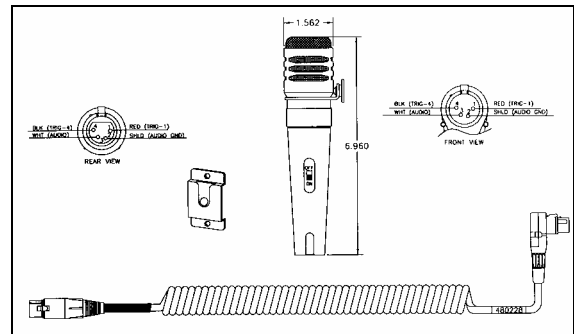

FIGURE 9: RUBBER COATED MICROPHONE 23217

1.8 WIRELESS MICROPHONE

The system 2000 16 channel wireless microphone, Receiver and Charging Cradle are custom designed units that allow for wireless PA communication from anywhere on the coach. The unit consists of a receiver mounted in the parcel area directly behind the driver, and a rechargeable hand-held microphone and charging unit. Instructions for proper use of the microphone are included in the "REI Operating Manual" which is provided in the technical publications box delivered with the vehicle.

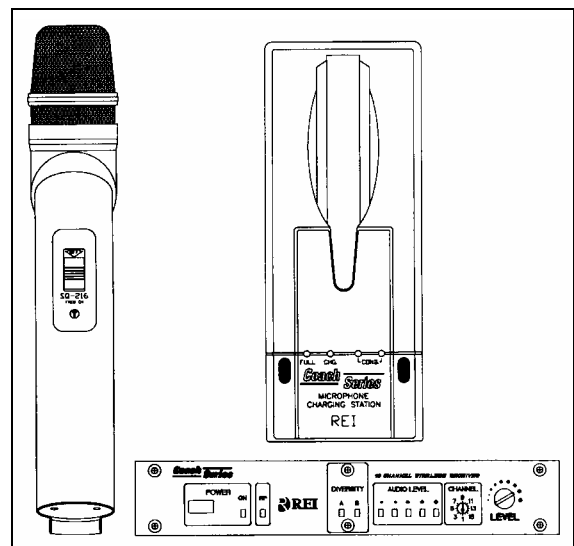

FIGURE 10: WIRELESS MICROPHONE 23226

1.9 TV TUNER

For TV tuner control descriptions, refer to fig. 11.

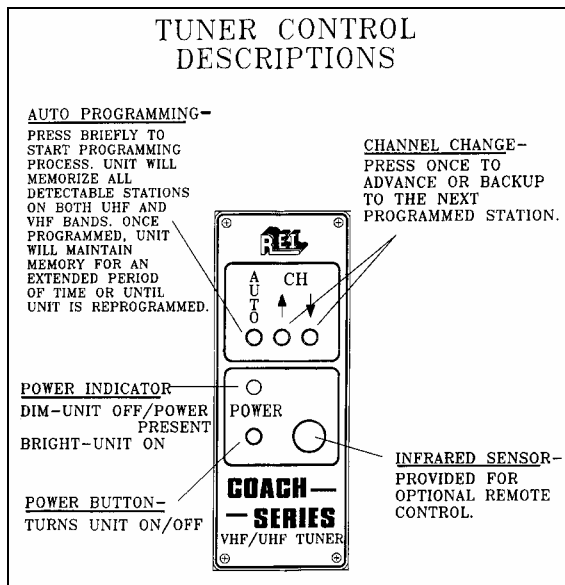

FIGURE 11: TUNER CONTROLS DESCRIPTION 23061

1.10 KARAOKE

The modified Panasonic DVD Player powers up automatically when the video system is activated. In addition to its normal functions controlled by the front panel, the unit can be controlled with the plug-in remote control, or the control head, which has access to the PLAY and STOP commands. A button on the front of the unit switches between normal PA mode and Sing-Along.

Instructions for proper use of the Karaoke system 2000 are included in the "Operating Manual" that is provided in the technical publications box delivered with the vehicle.

1.10.1 Karaoke Panasonic Sound System – DVD-A300



FIGURE 12: KARAOKE PANASONIC DVD-A300 23214

1.11 DRIVER'S SPEAKERS

The driver's speakers are mounted one on each side. This arrangement provides the driver with clear stereo sound. Controls for the driver's audio allow selection between the radio and the

auxiliary audio (independent of the passenger's speakers) or muting the speakers.

1.12 MONITOR

For monitor adjustment, refer to figure 13.

1.12.1 Removal

The front and side, ten-inch color monitors are slide mounted and retained by key locks. A LED indicator is provided on the back to indicate when the unit is "ON". The red button is the monitor ON/OFF switch and the pin style button is the circuit breaker reset button.

1. Place the battery master switch in the "OFF" position.
2. Unlock the monitor slide and pull towards the front of the monitor.
3. After removal, cover mount location using the monitor cover assembly and lock.

1.12.2 Installation

1. Remove monitor cover assembly located over mounting bracket if needed.
2. Align the monitor mount with the slide and slide monitor into place.
3. Lock the monitor or cover to prevent removal.

Note: Make sure connections are not bent or damaged. If monitor is not being replaced, immediately install the mounting cover.

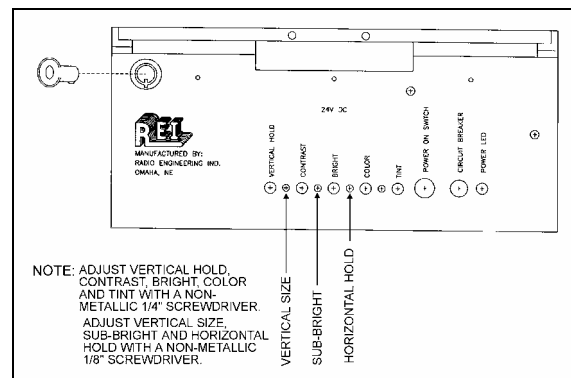

FIGURE 13: MONITOR HOUSING REAR PANEL 23076

Section 23: ACCESSORIES

1.13 SCENIC VIEWING SYSTEM

The scenic viewing system enables the passengers to view the road ahead of the vehicle. This system is composed of a camera, a dashboard mounted ON/OFF switch and the audio – video switching box located in the first parcel compartment on the driver's side (Figs. 14 & 15).

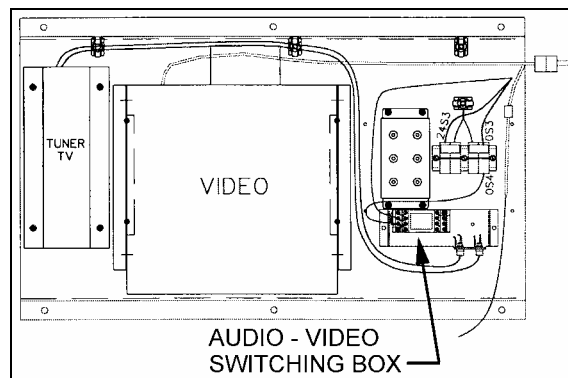

FIGURE 14: INSTALLATION IN PARCEL COMPARTMENT
23333

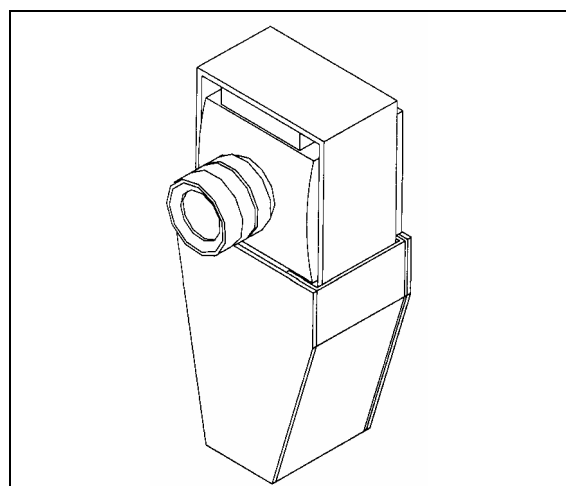

FIGURE 15: SCENIC VIEW CAMERA
23221

1.14 ROOF ANTENNA INSTALLATION

1. Find the desired location and drill a hole according to specification.
2. To remove dirt and grease, wash hole edge with alcohol.
3. If so equipped, remove foam padding ring from antenna to free the metal surface (foam can produce air bulbs in new rubber seal).
4. With SIKA 205, wash the vehicle hole edge and the antenna base surface, wait at least two (2) minutes for chemical evaporation.

5. Apply new seal SIKA 221 on both, vehicle hole edge and antenna base.
6. Fix the antenna in place.
7. Remove excess seal and complete a finishing joint all around the antenna base.

2. HUBODOMETER

2.1 DESCRIPTION

An optional wheel hubodometer (Fig. 16) may have been installed on the R.H. side of the drive axle. It indicates the total distance in miles or kilometers covered by the coach since it has left the factory, including road testing.

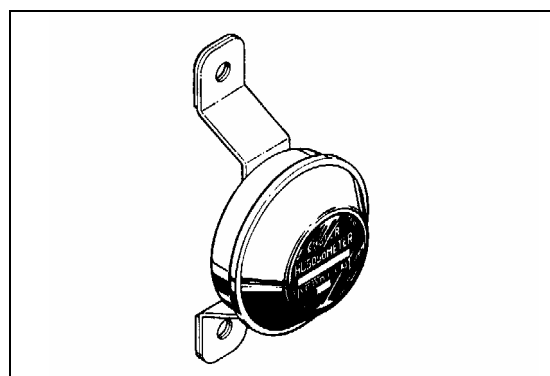

FIGURE 16: HUBODOMETER
23024

2.2 OPERATION

The hubodometer is calibrated for a specific wheel size (diameter). Wheel rotation causes a mechanism inside the hubodometer to record distance after a predetermined number of rotations. The unit should be serviced at a competent speedometer repair facility.

Note: Do not use paint, solvent or thinner on hubodometer face or on plastic hubcaps. Do not weld on hubodometer.

2.3 REMOVAL

To remove the unit, remove the two lock nuts and washers securing it to the wheel hub, and pull the unit off the studs.

2.4 INSTALLATION

Place the hubodometer unit over the wheel hub studs. Replace the lock washers and nuts. Torque stud nuts to 110-165 ft-lbf (150-225 N-m).

3. BACK-UP CAMERA AND MONITOR

An optional back-up camera is available which provides the driver with visual assistance when backing-up. The camera is automatically activated when the transmission is put in reverse gear and the ignition switch is "ON". The TV monitor is mounted on top of the dashboard. Refer to the Operator's Manual under "Controls & Instruments".

4. COLD STARTING AID (ETHER)

The vehicle can be equipped with an electrically-operated type ether cold starting aid designed to ease engine starting when temperature is low.

On vehicles equipped with cold starting aid, the system consists of the main following parts:

- Ether starting aid switch
- Ether cylinder
- Solenoid valve (24 V)
- Thermal cutout valve
- Atomizer

The control rocker switch is located on the dashboard. This switch is provided with a locking mechanism to avoid accidental use when engine is running. To activate the ether starting aid, proceed as follows:

1. Prior to cranking engine, press down rocker switch for three seconds to fill solenoid valve.
2. Release switch to discharge shot.
3. Allow three seconds for shot to discharge.
4. Start engine, use additional shots if necessary to keep engine running.

Caution: This practice should be performed only when absolutely necessary. Excessive use of fluid could result in serious engine damage.

The ether cylinder and solenoid valve assembly are mounted on the engine compartment wall and are accessible from the engine compartment R.H. side door.

The thermal cutout valve is mounted on the engine (radiator side). Its function is to prevent discharge of ether when engine is warm (over 90 F (32 C)). An atomizer is installed on top of the air intake duct (Fig. 17).

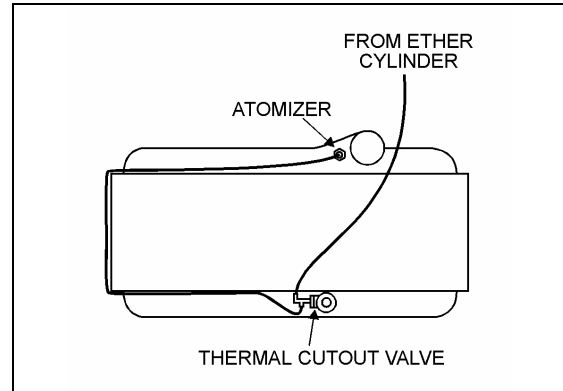

FIGURE 17: ENGINE

23032

4.1 PREVENTIVE MAINTENANCE

During the summer months, remove cylinder to avoid high temperature actuation of the cylinder safety relief device. Always screw valve cap into solenoid valve opening to prevent entrance of road dirt. When removing cylinder, be careful to prevent dirt from entering the valve.

4.2 TROUBLESHOOTING (IF SYSTEM IS NON-FUNCTIONING)

Warning: During the following test, direct free end of tube away from personnel and all sources of ignition as this fuel is extremely flammable. Avoid breathing vapors and contact fuel with skin. Never smoke during test.

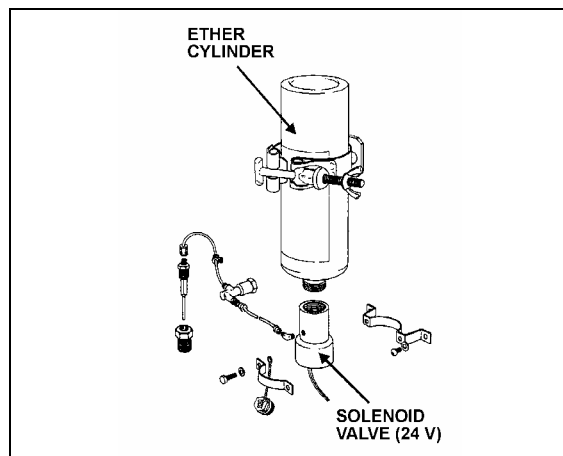

FIGURE 18: COLD STARTING AID

23048

Section 23: ACCESSORIES

1. Check cylinder for hand tightness and fuel supply (Fig. 18). Empty cylinder weight is approximately 17 oz (480 g); full cylinder weight is approximately 35 oz (990 g). If cylinder is empty, replace it. Before replacing cylinder, install new valve gasket in solenoid valve.
 2. If still not functioning, disconnect tubing at solenoid valve fitting. Actuate solenoid valve. (Ask an assistant to actuate solenoid valve using the rocker switch on the dashboard).
 - If solenoid valve is non-functioning, check electric circuit, (refer to wiring diagrams). If sound, remove and replace the solenoid valve. If not, repair electric circuit.
 - If valve is functioning, reassemble valve fitting and connect tube. Disconnect tube at thermal cutout valve from port "Tube from valve".
 3. Actuate the solenoid valve.
 - If fuel is not discharged from tube, remove tube and blow out or replace.
 - If fuel is discharged, connect tube to thermal cutout valve, and disconnect other tube.
 4. Actuate the solenoid valve.
 - If fuel is not discharged, replace the cutout valve.
- Note:** If engine coolant temperature is 90°F (32°C) or over, it is normal that fuel is not discharged as the valve is in closed position.
- If fuel is discharged, connect tube to thermal cutout valve, and disconnect tube from atomizer.
5. Actuate the solenoid valve.
 - If fuel is not discharged from tube, fuel line is clogged. Remove tube and blow out or replace.
 - If fuel is discharged, replace the atomizer.

5.3 THERMAL CUTOUT VALVE QUICK TEST

1. Engine coolant temperature must be below 90 F (32 C).

2. Temporarily disconnect tube at thermal cutout valve from port "Tube to atomizer".
3. Actuate solenoid valve (Ask an assistant to actuate solenoid valve by means of the rocker switch on the dashboard). Fuel should be discharged through the thermal cutout valve.

Warning: Avoid breathing vapors and contacting fuel with skin. Never smoke during test.

4. Reconnect tube to thermal cutout valve.
5. Start engine, using cold starting aid if necessary. Stop engine when it reaches operating temperature.
6. Disconnect tube at thermal cutout valve as in step 2, and repeat step 3. No fuel should be discharged.

5. DESTINATION SIGN

5.1 DESCRIPTION

The destination sign is located at upper front of the vehicle. Two models are available.

ELECTRICAL DESTINATION SIGN (Optional)

The lighting is provided with a fluorescent tube, which is activated by means of a rocker switch located on the dashboard. The destination sign is electrically operated, two rocker switches mounted side by side on the destination sign control its motor. The unwinding speed control switch determines the rolling speed without actuating it. The selecting switch (momentary type) controls and actuates the rolling direction (fig. 19).

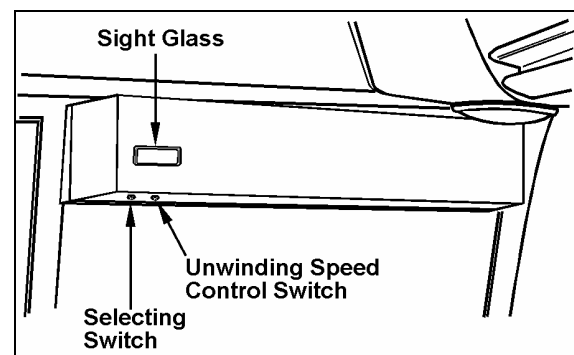

FIGURE 19: DESTINATION SIGN – ELECTRICAL 23122

5.2 MAINTENANCE

Inspect the following items regularly:

1. Check for free and easy mechanism movement.
2. Check for loose items on the sign mechanism, such as wire, loose clips, hanging tape, etc.
3. Check tension and condition of the two drive belts and replace as required.
4. Periodic lubrication is **NOT** recommended.

5.3 DESTINATION SIGN LIGHT REPLACEMENT

Refer to Section 06, Electrical System, paragraph "13.4.7 Destination Sign Light - Bulb Removal and Replacement" and "13.4.8 Destination Sign - Fluorescent Removal and Replacement".

5.4 ELECTRIC MOTOR REMOVAL AND INSTALLATION

To remove the electric motor:

1. Remove the six Phillips-head screws and washers retaining the destination sign cover, then carefully remove the cover from its location.
2. Disconnect wires from electrical motor.
3. Remove both screws retaining motor to destination sign frame (Fig. 20).
4. Slide motor upwards, then remove the drive belt.
5. Remove motor through the opening intended for this purpose.

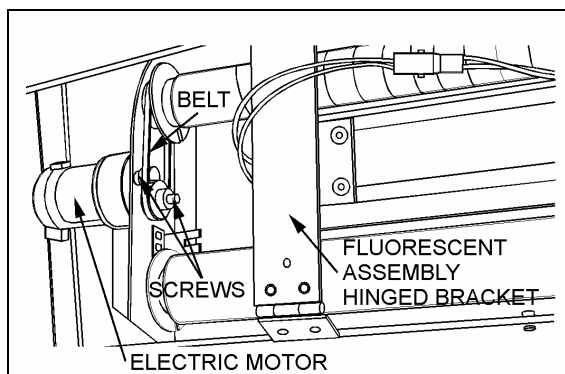

FIGURE 20: DESTINATION SIGN-ELECTRIC MOTOR 23034

6. Install the motor by reversing the above procedure.

5.5 SIGN CURTAIN REPAIR

In the event a destination sign curtain is torn, it can be repaired with 3M polyester tape or any equivalent cellophane tape. When repairing a tear, the tape should be used on both sides of the curtain.

ELECTRONIC DESTINATION SIGN (Optional)

To change the destination, depress the selecting switches until the desired destination appears in the LCD display.

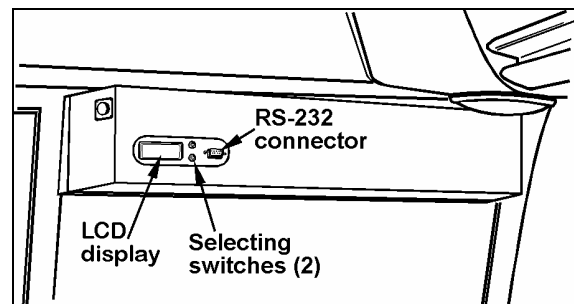

FIGURE 21; DESTINATION SIGN – ELECTRONIC 23123

Note: The destination sign must be programmed with a computer connected to the RS-232 connector prior to first use. Follow the instructions on the computer disk to install and run the software.

Note: All destination sign models are equipped with lights (bulb light or fluorescent) which illuminates automatically when the headlight or fog light switch is activated.

6. LAVATORY

6.1 DESCRIPTION

The lavatory is located in the rear R.H. corner of the coach. It is equipped with a chemical flush toilet, bathroom tissue dispenser, washbasin, towel dispenser, waste container, mirror, ashtray, and a cleaning cabinet. A liquid soap dispenser and moist towel dispenser are optional.

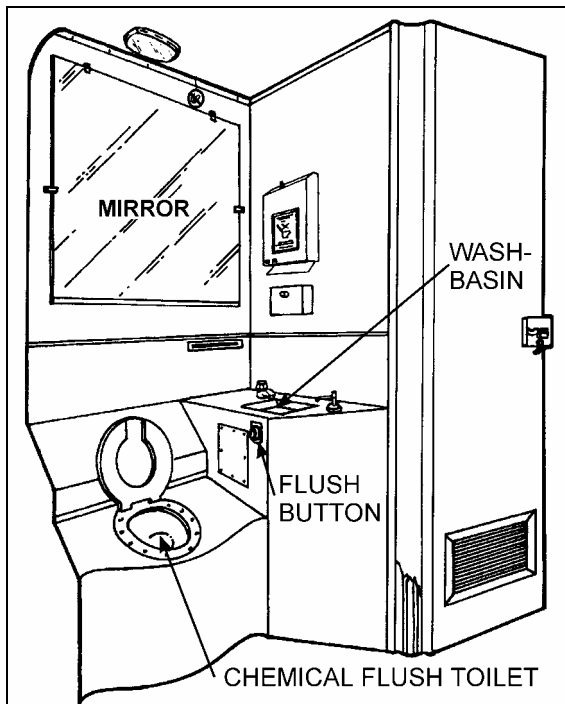

FIGURE 22: LAVATORY

23335

Locking the lavatory door from the inside will illuminate a fluorescent light in the lavatory and two outside signs to indicate occupation. One sign is located on the outer wall of the lavatory and another sign is located over the windshield. An indicator light on the dashboard will illuminate to inform the driver when the lavatory is occupied. A night-light is permanently lit in the lavatory when the ignition switch is in the ON position.

If emergency assistance is required, the lavatory occupant can actuate a buzzer that will sound in driver's area. The buzzer's push-button (c/w instruction label) is located on the inner curbside wall of lavatory.

The lavatory has it's own ventilation system that operates only when ignition switch is in the "ON" position. An auxiliary sump tank (Fig. 27) (optional) allows main tank to be drained by manually opening an interconnecting tank valve (4, Fig. 27). Lavatory can then be operated for longer periods until coach can be serviced at a facility equipped for disposal.

The fresh water tank, located behind compartment mirror (Fig. 26), is equipped with a thermal drain valve that will drain the tank when water temperature approaches the freezing point preventing damage to the tank (Fig. 26). The fresh water supplies water to the washbasin by gravity. Two tubes are connected on top of

the tank. One serves as overflow as well as a vent tube and runs along the curbside wall to the engine R.H. side compartment (7, Fig. 27) while the other tube is connected to the fresh water fill connection which is also located in engine R.H. side compartment (2, Fig. 27). A third tube connected in the bottom of the fresh water tank allows fresh water to flow to the washbasin faucet. Water from washbasin drain tube flow to the main sump tank.

Also, a drain hole located on lavatory floor drain water splashed on the floor to the engine R.H. side compartment.

6.2 MAINTENANCE

The servicing procedure for the lavatory is described in the "Operator's Manual" included in the technical publications box delivered with the vehicle.

6.3 VENTILATION FAN

6.3.1 Description

The lavatory ventilation fan, mounted in engine compartment behind the oil reserve tank (Fig. 23), serves two purposes. It exhausts objectionable odors and provides a constant air circulation in the lavatory compartment by heating or cooling the lavatory with the vehicle ambient air. Air flows in the lavatory compartment through a vent grill located on the lavatory door and exhausts through a grill located next to the toilet.

Note: This fan runs constantly when the ignition switch located on the dashboard is in the "ON" position.

6.3.2 Maintenance

The frequency of preventive maintenance should be determined according to vehicle mileage and operating conditions. However, it is recommended to check this item every 50,000 miles (80 000 km) or once a year, whichever comes first.

Remove fan and motor assembly. Check for fan housing wheel and motor free operation. When defective motor occurs, new motor must be installed.

6.3.3 Removal and Installation

1. With the engine compartment rear doors opened, remove hose clamp securing duct to ventilation fan inlet, and disconnect duct.

2. Disconnect the ventilation motor wiring connector.
3. Remove the support bracket screw. Remove the three bolts fixing the ventilation fan housing support. Remove the ventilation fan assembly from its location.
4. The unit can now be disassembled and motor replaced.
5. Reverse previous steps to reinstall ventilation fan assembly on vehicle.

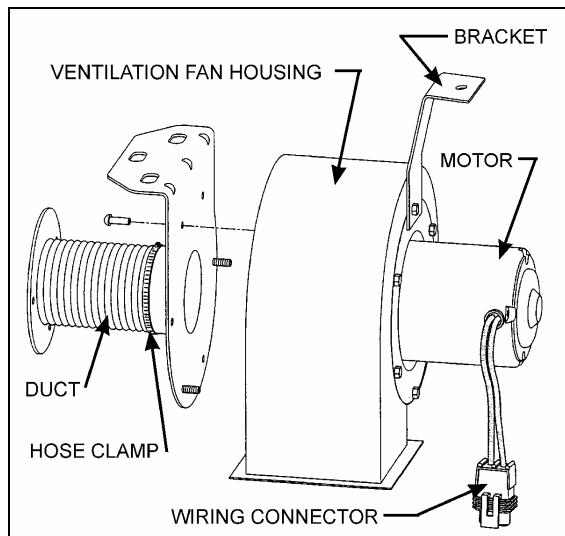

FIGURE 23: VENTILATION FAN INSTALLATION 23222

6.4 DOOR LOCK

Lavatory door lock has inside and outside handles, as well as an inside latch to lock door from inside the compartment. If the lock fails to release, the door can be opened from the outside using a special key which is supplied to the driver. Lock assembly can be removed from the door, then readily disassembled and parts replaced, if necessary (Fig. 24). A thin coat of lubricant on all moving parts will ensure trouble-free operation.

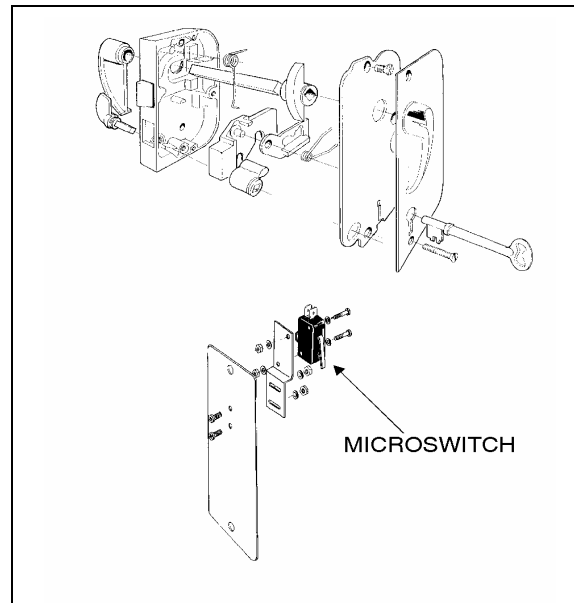

FIGURE 24: DOOR LOCK

23037

6.5 LAVATORY LIGHT

The lavatory light is installed on ceiling. A microswitch, which is mounted in the door exterior frame, is activated by the door lock mechanism upon locking to energize the circuit. This switch is readily serviced by removing the two Phillips-head screws securing the mounting plate to the door exterior frame.

Proceed as Section 06, Electrical System, *Dome, Rear Roof and Lavatory Lights* for lights replacement.

6.6 LAVATORY NIGHT-LIGHT

The lavatory night-light is illuminated as soon as the ignition switch is set to the "ON" position. See Section 06, Electrical System, *Parcel Rack / Lavatory Night Light - "Bulb Removal and Replacement"* for lights replacement.

6.7 EMERGENCY BUZZER

The lavatory emergency buzzer is mounted on the inner curb side wall of lavatory and sounds when the emergency call push-button switch in the lavatory compartment is activated. For specific wiring information, refer to wiring diagrams. To remove the emergency call push-button switch, proceed as follows:

1. Remove both phillips-head screws retaining pushbutton switch plate to wall.

Section 23: ACCESSORIES

2. Remove steel plate located on L.H. side of pushbutton switch.
3. Remove switch through this opening, taking care to disconnect electric wires.

6.8 FRESH WATER TANK

One panel allows access to the fresh water tank. It is located behind the toilet mirror. Remove the tank as follows:

1. Remove the mirror.
2. Remove the fresh water tank tubings, bolts, and different connectors.
3. Remove the tank from the wall.
4. Reverse previous steps to reinstall fresh water tank assembly on vehicle.

6.8.1 Fresh Water Tank Draining

The fresh water tank can be drained by simply opening the fresh water drain cock (Fig. 26). Don't forget to close cock when draining is done.

Note: The fresh water reservoir is equipped with a thermal valve which is set to open at about 35°F, thereby automatically draining the reservoir in near-freezing temperatures.

Routine draining and filling of lavatory tanks should be performed by maintenance personnel only. If engine or heating failure occurs in extreme weather conditions, emergency draining of water tanks should be performed under the most suitable conditions and should at all times be supervised by driver.

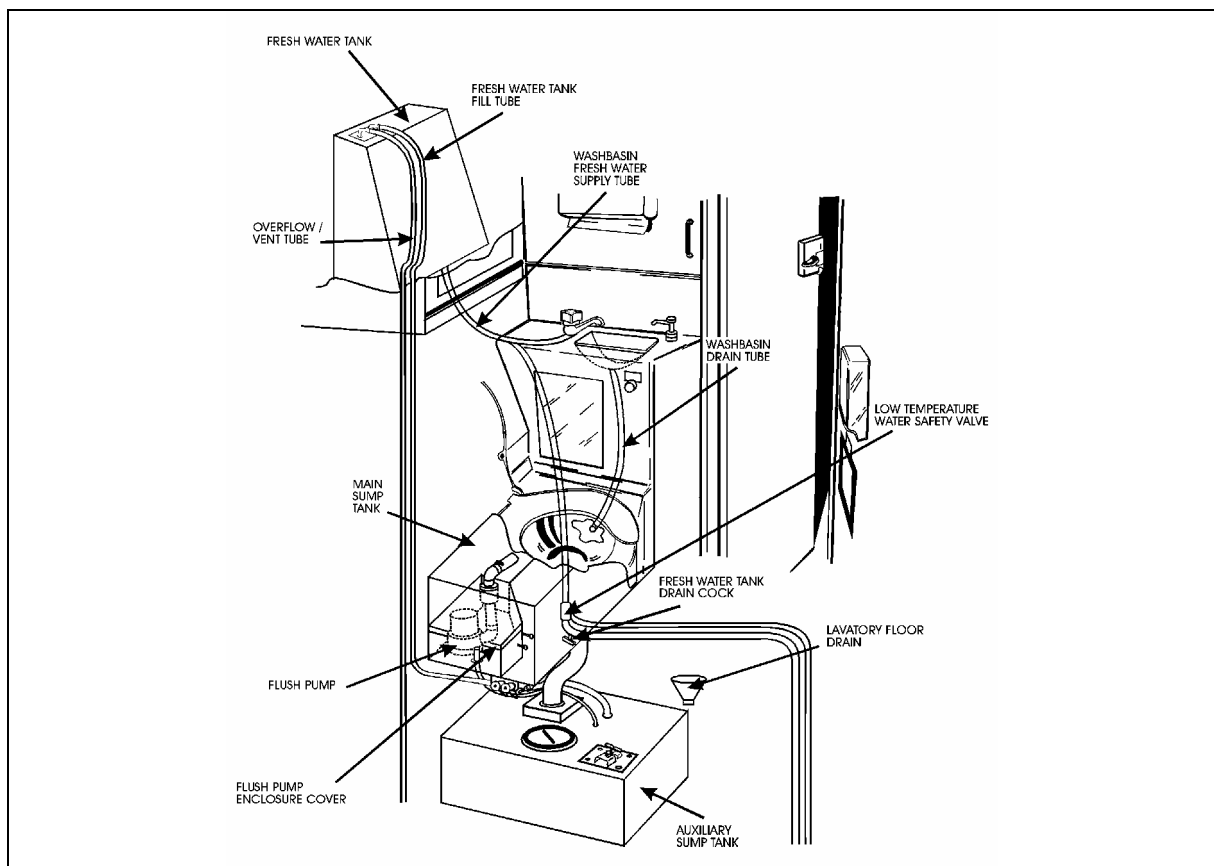

FIGURE 25: FUNCTIONING OF LAVATORY

23051

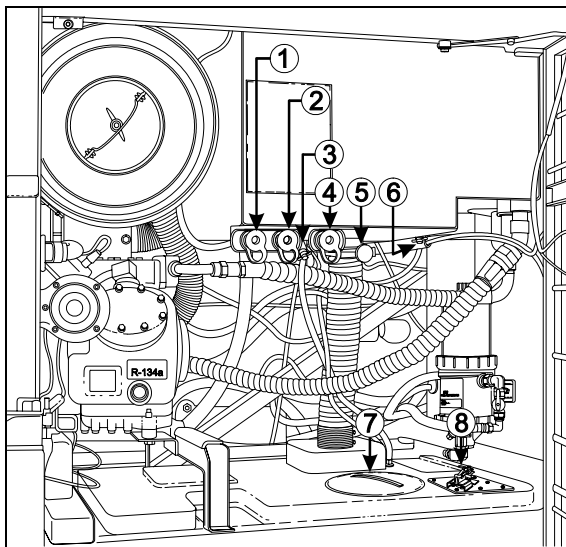

FIGURE 26: F/W TANK SERVICE VALVES 23025

- 1.....Fresh water tank fill connection
- 2..... Main sump tank fill connection
- 3..... Main sump tank overflow cock
- 4..... Cleaning kit hose connector
- 5.....Main sump tank drain valve
- 6..... Fresh water tank drain cock
- 7.....Auxiliary sump tank access cap
- 8.....Auxiliary sump tank drain valve

6.8.2 Fresh Water tank Filling

Connect the fresh water supply hose to the fresh water reservoir fill connection (Fig. 26) located in the curb-side engine compartment. Fill the reservoir until the overflow tube leaks, signaling that the reservoir is full.

Warning: Never put antifreeze in fresh water tank; antifreeze is toxic.

Warning: If tank has not been drained for an extended period of time, draining and filling operations must be repeated three (3) times in order to clean tank and eliminate contaminated water.

6.9 LIQUID SOAP DISPENSER

A liquid soap dispenser may have been installed as optional equipment. To refill dispenser, proceed as follows:

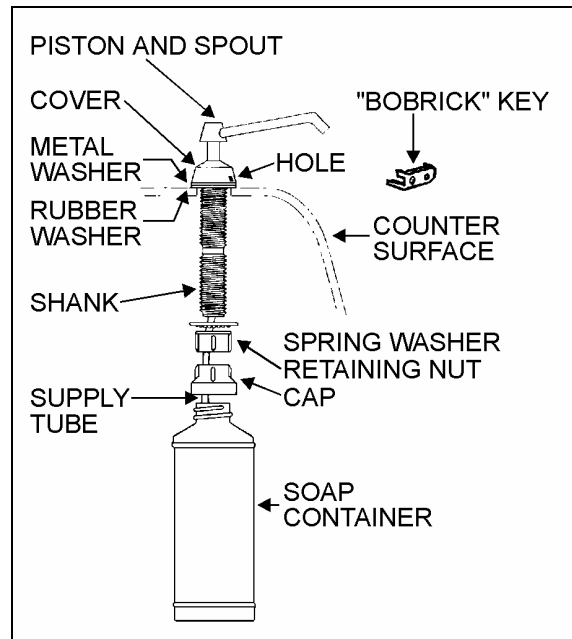

FIGURE 27: LIQUID SOAP DISPENSER 23039

1. Turn cover slightly clockwise until it stops.
2. Insert projection at end of "BOBRICK" key into rectangular hole in cover (Fig. 20). Push straight in. While holding "BOBRICK" key in, turn cover counterclockwise about 1/8 turn.

Caution: Do not use "BOBRICK" key to turn cover.

3. Lift out piston and spout, cover and supply tube.
4. Fill dispenser with soap. This model can dispense vegetable oil soaps, synthetic detergents, and lotion soaps.

Caution: Never use abrasive cleaners.

5. Replace supply tube, piston, and spout mechanism reversing the steps above.
6. Secure the cover by turning clockwise until lock snaps into position.

Note: The dispenser requires priming when extremely viscous lotion soaps are used. Remove piston and spout, cover and supply tube assembly. Pump water into assembly, then replace into dispenser.

6.10 FLUSH PUSH-BUTTON

The green flush push-button is located near the toilet. Press on push-button to actuate a pneumatic timer located on the other side of wall. This timer allows an electric current flow during a preset time to a pump into the sump tank.

6.10.1 Pneumatic Timer Removal and Installation

1. Unscrew and remove the flush push-button locking ring.
2. Remove steel plate located on L.H. side of pushbutton switch.
3. Remove pneumatic timer through this opening, taking care to disconnect electric wires.

Note: Care must be taken to avoid losing the spacers installed on the mounting sleeve.

4. Reverse the above procedure to reinstall timer. The recommended torque for the lock nut is 15 ft-lbf (21 N·m).

6.10.2 Timer Adjustment

Timer can be adjusted from 0.2 second to 3 minutes by turning the time adjustment screw clockwise to increase time, and counterclockwise to decrease time. To gain access to the time adjustment screw, repeat steps 1, 2 and 3 in the previous paragraph "6.10.1 Pneumatic Timer Removal and Installation".

6.11 FLUSH PUMP

The submersible-type flush pump is mounted inside an enclosure in the sump tank (Fig. 26). The enclosure is provided with a screened side which, serves as a strainer to prevent solid matters from entering the pump.

The pump requires no periodic maintenance other than cleaning of the strainer side using a water jet introduced through the circular cap opening, once the sump tank is completely drained. The pump can run dry periodically without damage. However, for maximum seal life, the run dry periods should be kept to a minimum.

Caution: If vehicle is stored for an extended period of time, make sure to clean the strainer as solid matter will tend to pack, and will necessitate replacement of strainer.

6.11.1 Flush Pump Removal

1. Remove the toilet to gain access to the pump enclosure.
2. Remove the flush pump enclosure cover
3. Unsnap the flush pump.

6.12 SUMP TANKS

6.12.1 Main Sump Tank Draining

When recirculating water in the toilet is soiled, drain main sump tank. If equipped with the optional auxiliary sump tank, drain the main sump tank contents into the auxiliary tank and perform the filling procedure of the main tank.

6.12.2 Main Sump Tank Filling

Open the main sump tank overflow cock and connect a water supply hose to the toilet sump tank fill connection. The main tank is full when water starts flowing through the clear overflow tube. Close main sump tank overflow cock when the tank is full.

Caution: In cold weather, add 2 gallons (9 liters) of antifreeze (e.g.: ethylene glycol) in the toilet before filling main tank.

6.12.3 Auxiliary sump Tank Draining

Remove drain cap located under auxiliary sump tank then pull the auxiliary sump tank drain valve lever up. Remove the access cap and flush tank with clean water. To close, push the valve lever completely down to its locking position. Reinstall access and drain caps.

Caution: Lavatory tanks should be serviced only at suitably equipped stations.

Note: It is unlawful to dump sump tank contents in any location other than those designated as such.

When a full draining is required, clean main tank by repeating the draining and filling operations while leaving the auxiliary sump tank drain cock opened. Close cocks and pour a pack of commercial toilet deodorant (Prévost part #900329) in toilet before adding the antifreeze and starting final filling of main tank.

Warning: The toilet deodorant contains products that can be very irritating to skin. Use rubber gloves when handling and then clean toilet seat.

Warning: Antifreeze must comply with the effective environmental act.

Caution: When cold weather is expected and there is no antifreeze in the tank, both sump tanks must be drained.

Note: If there is no antifreeze solution in the tank, there is less risk of freezing if engine is operating due to the heat it produces.

New vehicles do not have an antifreeze solution in the sump tanks at time of delivery.

7. AIR HORN VALVE

The air horn valve is located in the front service compartment and the air horn valve button is on the steering wheel center.

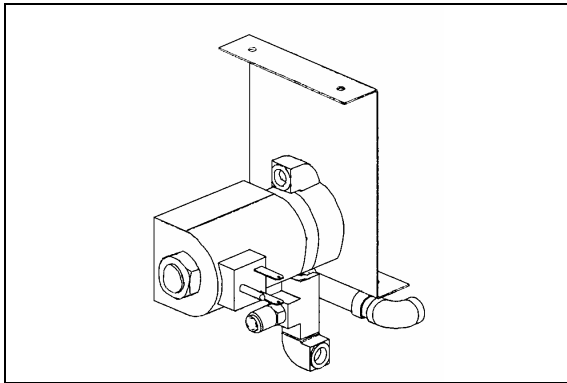

FIGURE 28: AIR HORN VALVE

23330

7.1 AIR HORN VALVE MAINTENANCE

When needed, the air horn valve can be serviced or replaced using the following procedure:

1. Unplug the cable connector;
2. Disconnect the air tubes;
3. Loosen the retaining bolts;
4. Service or replace the air horn valve;
5. Reinstall by reversing procedure.

8. WINDSHIELD WIPERS AND WASHERS

8.1 GENERAL DESCRIPTION

Note: When installing a wiper motor, arm or blade, follow recommended procedures to prevent misalignment, binding or malfunction. Check the windshield washer liquid hoses, fittings and connectors to be sure they are properly connected and seal with no restriction to the flow of washer liquid. Check that wiper arms have the proper sweep position and the washer nozzles are aimed so that spray is within the proper wiper pattern.

The windshield wipers are controlled by one electric wiper motor that is accessible for maintenance after removing the appropriate access panel beside the footwell (refer to figure 29).

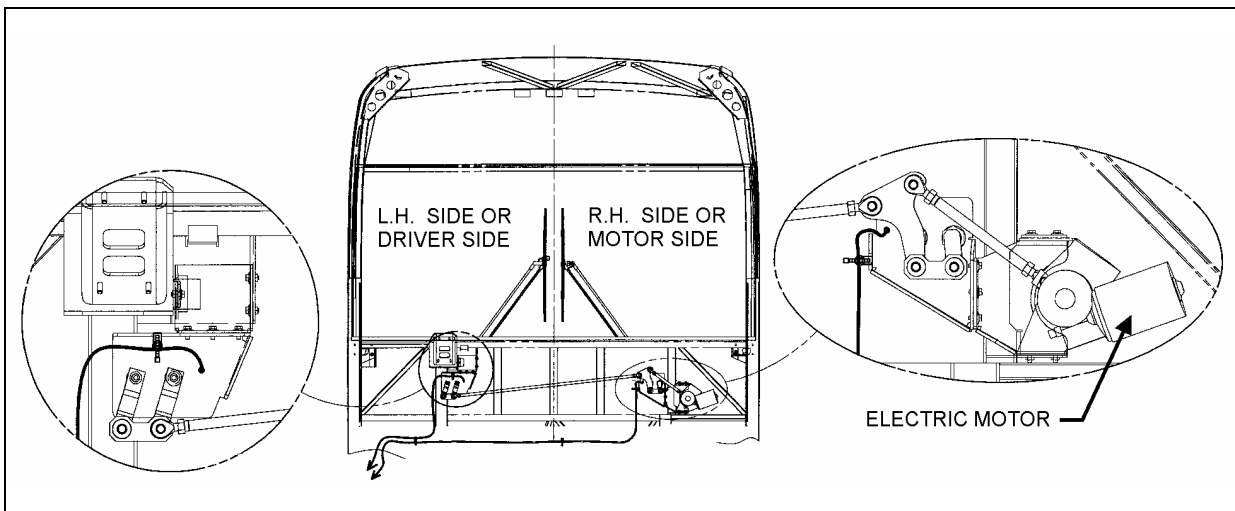

FIGURE 29: WINDSHIELD WIPER INSTALLATION

23331

Turn the multifunction lever forward to activate windshield wipers (item 2, fig. 30). The first position operates the wipers at low speed and the second position operates the wipers at high speed. Turning the lever backwards will operate the wipers in the intermittent mode.

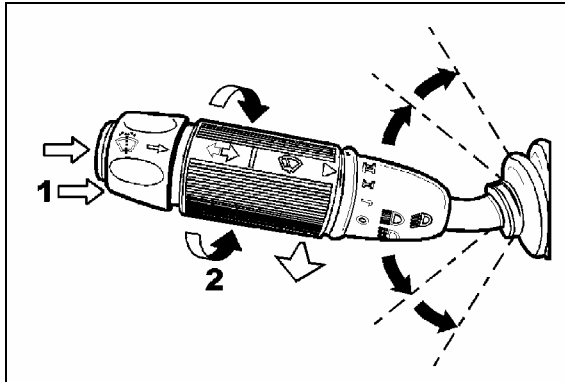

FIGURE 30: MULTIFUNCTION LEVER 23133

The windshield washer pumps are electrically operated and are controlled by a washer controlling ring on the multifunction lever (item 1, fig. 30).

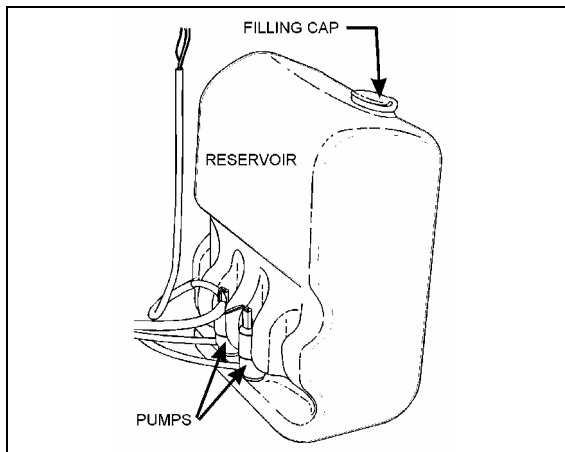

FIGURE 31: WINDSHIELD WASHER RESERVOIR 23220

The windshield washer reservoir is located in the front service compartment (Fig. 31). This unit pumps the washer liquid to the spray nozzles where it is dispersed across the windshield.

8.2 WIPER ARM

Check operation of the wipers for proper blade sweep and angle.

Caution: Do not attempt to manually move the wiper arms to make wiper blade sweep adjustments as damage to the wiper linkage or motor

may occur. If it is necessary to adjust the sweep of blades, remove the arms and make adjustment by positioning the arms using serration on the wiper arm pivot shafts.

8.2.1 Wiper Arms Positioning

1. Reinstall the wiper arms and position as shown in figure 34. Before positioning the wipers at their final position, tighten the nuts to 9 lbf-ft (12 Nm) at first.
2. To find the final position of the wiper arms, lift then release the wiper arm so it falls back on the windshield

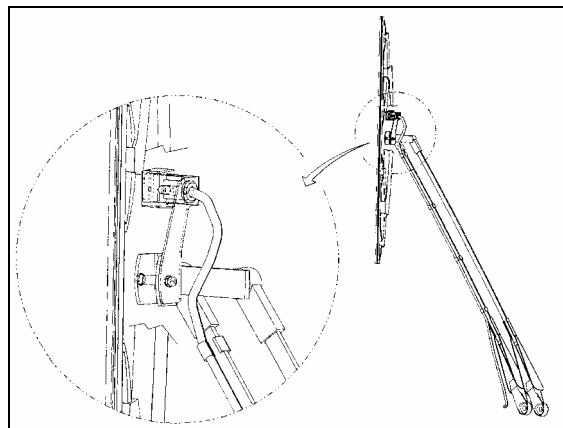

FIGURE 32: WINDSHIELD WIPER (MOTOR SIDE) 23224

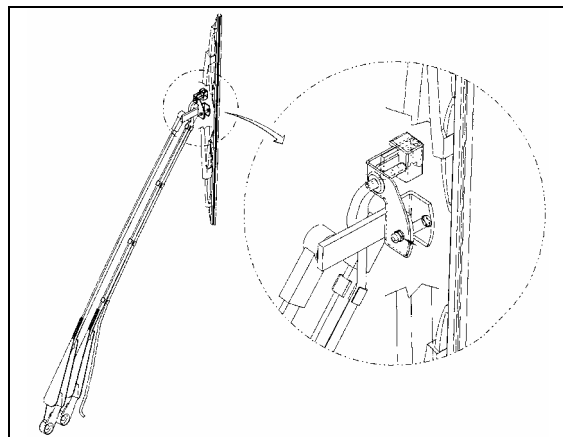

FIGURE 33: WINDSHIELD WIPER (DRIVER SIDE) 23225

3. When the final position is found, tighten the wiper arm nuts to 18 lbf-ft (25 Nm). Wait 30 minutes and tighten again to 18 lbf-ft.
4. Lower the protective cover.
5. Connect the windshield washer tubing at the base of the wiper arm.

6. Check the adjustment on a wet windshield.

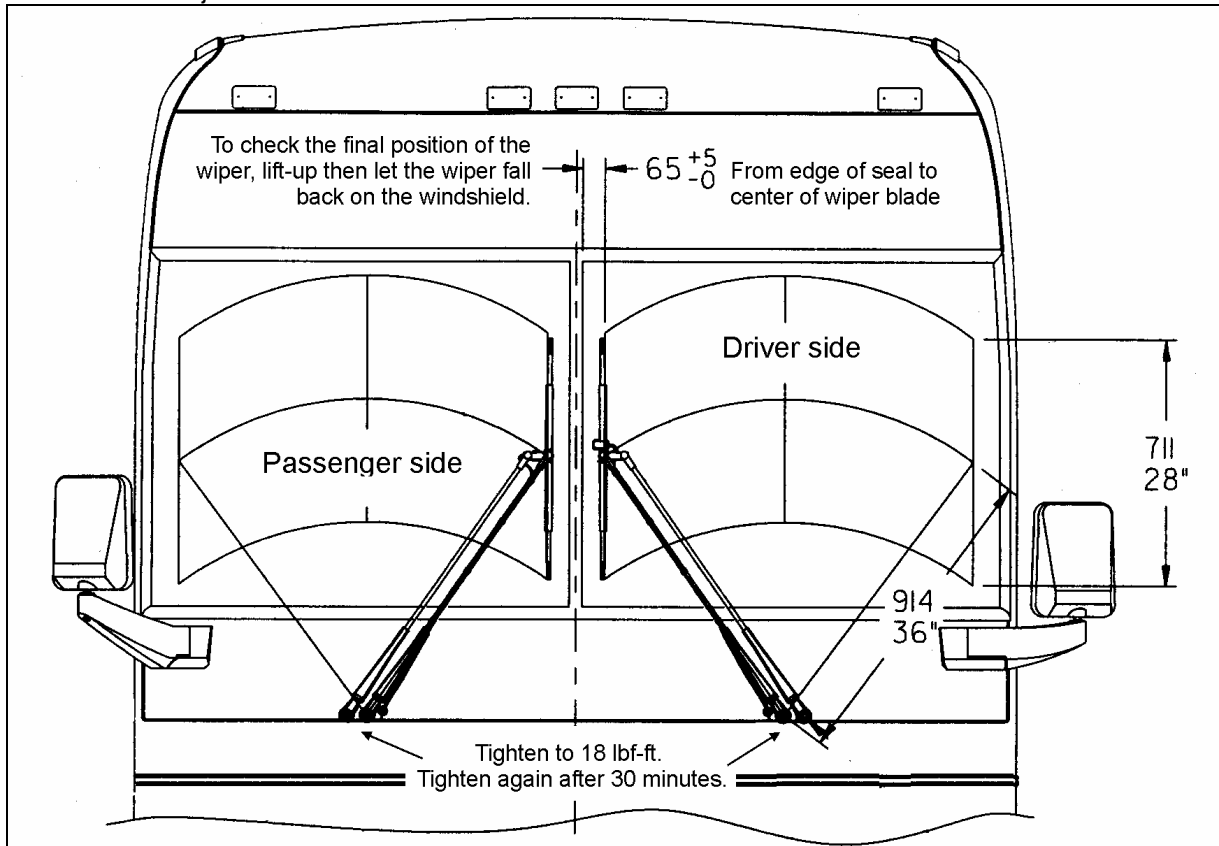

FIGURE 34: WIPER ARMS POSITIONING

23253

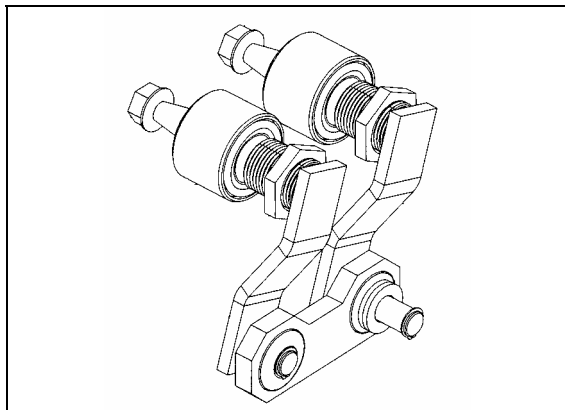

FIGURE 35: DRIVING MECHANISM (DRIVER SIDE) 23334

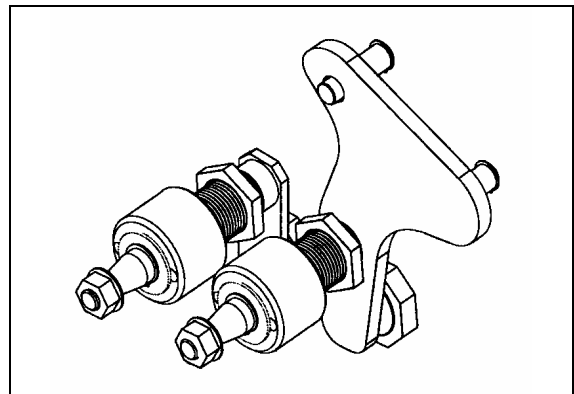

FIGURE 36: DRIVING MECHANISM (MOTOR SIDE) 23254

Section 23: ACCESSORIES

8.3 WINDSHIELD WIPER MOTOR

8.3.1 Windshield Wiper Motor Replacement

The windshield wiper motor is located at lower front of the vehicle, behind the defroster panel. Refer to figure 29 for motor location.

Warning: Park vehicle safely, apply parking brake, stop engine and set battery master switch to the "OFF" position prior to working on the vehicle.

1. Remove the Phillips-head screws retaining the defroster panels, and remove panels.
2. Disconnect wiring connector from the windshield wiper motor.
3. Loosen clamping screw retaining the lever at the end of the motor driving shaft.
4. Remove the three bolts holding the motor to the steel plate.
5. Remove the windshield wiper motor (Prévost #800328), reverse removal procedure to reinstall.

8.4 TROUBLESHOOTING

SYMPTOM	PROBABLE CAUSE	REMEDY
FAIL TO SPRAY WASHER FLUID	A. Reservoir empty. B. If below 32°F (0°C), improper washer fluid frozen. C. Contamination in tubing or nozzles. D. Tubing damage. E. Tubing bent (kinked) or off one or more connections.	A. Add proper fluid. B. Store coach or parts in heated area, then purge system with low-temperature solution. C. Remove with compressed air, if severely clogged, replace items. D. Replace section. E. Realign tubing and/or refit. Trim end to ensure proper fit or replace.
INADEQUATE SPRAYING	A. Tubing failure.	A. Replace tubing.
SLOW OPERATION	A. Improper solution. B. Jet stream improperly directed. C. Check if valve is stuck in the open position.	A. Replace with proper type solution. B. Reposition nozzles. C. Remove, clean or replace.

9. SPECIFICATIONS**AMPLIFIER**

Make..... R.E.I.
 Model..... AMP-2000
 Power source24 volts DC Negative ground
 Current 8 Amps maximum
 Frequency Response..... 10-30,000 Hz
 Output..... 90 watts/channel maximum power
 65 watts/channel RMS at 4 ohm @ 0.5 T.H.D.
 Signal to noise ratio.....86 dB
 Supplier number..... 700189
 Prévost number..... 900802

AM/FM RADIO CASSETTE PLAYER

Make..... Panasonic
 Model..... CQ-R115SEUC
 Power source12 volts
 Supplier number..... 700590
 Prévost number..... 900917

6 DISC CD CHANGER

Make..... R.E.I.
 Supplier number..... 700467
 Prévost number..... 900822

12 DISC CD CHANGER

Make..... R.E.I.
 Supplier number..... 700473

SPEAKER

Make..... Robert Bosch
 Max. power.....90 watts
 RMS power40 watts
 Freq. response..... 45 Hz - 24 kHz
 Sensitivity92 dB
 Impedance 4 ohms
 Supplier number..... RPSPKR54
 Prévost number..... 900765

CONTROL HEAD

Make..... R.E.I.
 Model..... C-2000
 Supplier number..... 700227
 Prévost number..... 900803

VIDEO TAPE RECORDER

Make..... R.E.I.
 Model..... SYS-2000
 Supplier number..... 700454
 Prévost number..... 900806

Section 23: ACCESSORIES

BOOM-TYPE MICROPHONE

Make..... R.E.I.
Supplier number..... 480076BK
Prévost number..... 900763

HANDHELD PRIORITY MICROPHONE

Make..... R.E.I.
Supplier number..... 480015
Prévost number..... 900808

RUBBER COATED MICROPHONE

Make..... R.E.I.
Supplier number..... 480228
Prévost number..... 900745

16 CHANNEL WIRELESS MICROPHONE

Make..... R.E.I.
Supplier number..... 700598
Prévost number..... 900954

16 CHANNEL WIRELESS MICROPHONE CHARGING STATION

Make..... R.E.I.
Supplier number..... 700532
Prévost number..... 900953

16 CHANNEL WIRELESS MICROPHONE RECEIVER

Make..... R.E.I.
Supplier number..... 700599
Prévost number..... 900952

TV TUNER

Make..... R.E.I.
Power source 24V
Supplier number..... 700471
Prévost number..... 900814

KARAOKE

Make..... Panasonic
Model..... DVD-A300
Supplier number..... 700565
Prévost number..... 900883

TV MONITOR

Make..... R.E.I.
Power source 24V
Supplier number..... 700182
Prévost number..... 900809

HUBODOMETER (US model: miles)

Make..... Stemco
Supplier number..... 650-0593
Prévost number..... 650002

HUBODOMETER (Canada model: km)

Make..... Stemco
 Supplier number..... 650-0025
 Prévost number..... 650117

ELECTRIC DESTINATION SIGN (FLUORESCENT TUBE)

Make..... General Electric
 Length 30" (76 cm)
 Outside diameter 1" (25 mm)
 Wattage 20
 Color Cool white
 Quantity 1
 Supplier number..... F30T8 CW4
 Prévost number..... 830120

ELECTRONIC DESTINATION SIGN

Make..... Pocatec
 Supplier number..... 9000230
 Prévost number..... 940050

LAVATORY VENTILATION FAN MOTOR

Make..... Aurora
 Type RG500EF
 Voltage 24 volts DC
 Rotation R.H.
 Supplier number..... 131.40.50
 Prévost number..... 870844

LAVATORY FLUORESCENT TUBES

Make..... General Electric
 Model..... F15T8CW
 Length 18" (45 cm)
 Wattage 15
 Quantity 2
 Prévost number..... 830102

EMERGENCY BUZZER SWITCH (PUSH BUTTON)

Make..... Cole Hersee Co.
 Voltage 24 V
 Supplier number..... 40224
 Prévost number..... 562117

FRESH WATER TANK

Make..... Prévost
 Capacity 18 US gal (68 liters)
 Prévost number..... 401591

Section 23: ACCESSORIES

FLUSH PUSH BUTTON PNEUMATIC TIMER

Make..... Furnas
Type Resettable
Time 0,2 to 180 seconds
Supplier number..... 55-AA
Prévost number..... 900348

FLUSH PUMP

Make..... RULE 2000
Model number 12 - 24 V
Power source 24 volts DC
Capacity 1450 GPH
Prévost number..... 900960

AIR HORN

Make..... Allied Signal Inc.
Supplier number..... 101493
Prévost number..... 640093

AIR HORN VALVE

Make..... Allied Signal Inc.
Supplier number..... 228672
Prévost number..... 640128

WINDSHIELD WIPER MOTOR

Make..... BOSCH
Supplier number..... 0390442401
Prévost number..... 800328

WIPER (BLADE)

Make..... BOSCH
Supplier number..... 3398110095
Prévost number..... 800329

WIPER ARM

Make..... BOSCH
Supplier number..... 6002UWA060
Prévost number..... 800331