

SECTION 14: STEERING

CONTENTS

1. STEERING SYSTEM	14-3
1.1 DESCRIPTION	14-3
2. POWER STEERING GEAR	14-4
2.1 DESCRIPTION	14-4
2.2 POWER STEERING GEAR REMOVAL	14-5
2.3 POWER STEERING GEAR INSTALLATION	14-5
3. BLEEDING POWER STEERING HYDRAULIC SYSTEM	14-5
4. HYDRAULIC PRESSURE TEST	14-5
5. TROUBLESHOOTING	14-5
6. POWER STEERING HYDRAULIC PUMP	14-5
6.1 DESCRIPTION	14-5
6.2 REMOVAL AND INSTALLATION	14-5
6.3 MAINTENANCE.....	14-6
7. STEERING WHEEL	14-6
7.1 REMOVAL.....	14-6
7.2 INSTALLATION	14-6
8. STEERING COLUMN	14-6
8.1 REMOVAL.....	14-6
9. TURNING ANGLE ADJUSTMENT	14-6
10. STEERING LINKAGE ADJUSTMENT	14-7
11. PITMAN ARM	14-7
11.1 REMOVAL.....	14-7
11.2 INSTALLATION	14-8
11.3 ADJUSTMENT	14-8
12. MAINTENANCE	14-8
12.1 POWER STEERING RESERVOIR AND FILTER	14-9
12.1.1 <i>Oil Level Check Procedure</i>	14-9
12.1.2 <i>Filter Replacement</i>	14-9
12.2 STEERING STABILIZER CYLINDER (DAMPER).....	14-10
12.3 DRAG LINK	14-10
12.4 POWER STEERING HYDRAULIC PUMP	14-10
13. DRIVING TIPS	14-10
14. TORQUE SPECIFICATIONS	14-11
15. SPECIFICATIONS	14-12

ILLUSTRATIONS

FIGURE 1: STEERING SYSTEM AXLE SETUP 14-3
FIGURE 2: POWER STEERING GEAR 14-4
FIGURE 3: FRONT SERVICE COMPARTMENT..... 14-4
FIGURE 4: STEERING COLUMN 14-6
FIGURE 5: PITMAN ARM ADJUSTMENT 14-7
FIGURE 6: FIXING NUT PUNCH MARK 14-8
FIGURE 7: HYDRAULIC FLUID RESERVOIR LOCATION 14-9
FIGURE 8: POWER STEERING FLUID RESERVOIR 14-9
FIGURE 9: STEERING STABILIZER (DAMPER)..... 14-10
FIGURE 10: DRAG LINK COMPONENTS 14-11
FIGURE 11: TIE ROD END..... 14-11
FIGURE 12: FRONT AXLE COMPONENTS..... 14-11

1. STEERING SYSTEM

1.1 DESCRIPTION

The steering system consists of the steering wheel and column assembly, a vane-type hydraulic pump, reservoir, filter, interconnecting system lines and hoses, integral power steering gear, linkage and steering damper (Fig. 1). The steering linkage includes the pitman arm, drag link, steering arm, tie rod arms and tie rod.

Hydraulic components are added to transmit, increase and regulate steering control forces.

These elements are:

1. Steering stabilizer (damper);
2. A vane type hydraulic pump; and
3. Hydraulic reservoir and hoses.

The steering stabilizer reduces road shocks and vibrations in the system. The steering gearbox is self powered and provides movement with power assistance to the left wheel.

Steering stability and tire wear are influenced by wheels, hubs, tires, air suspension, brakes, front suspension and front end alignment which are all covered in their respective sections in this manual.

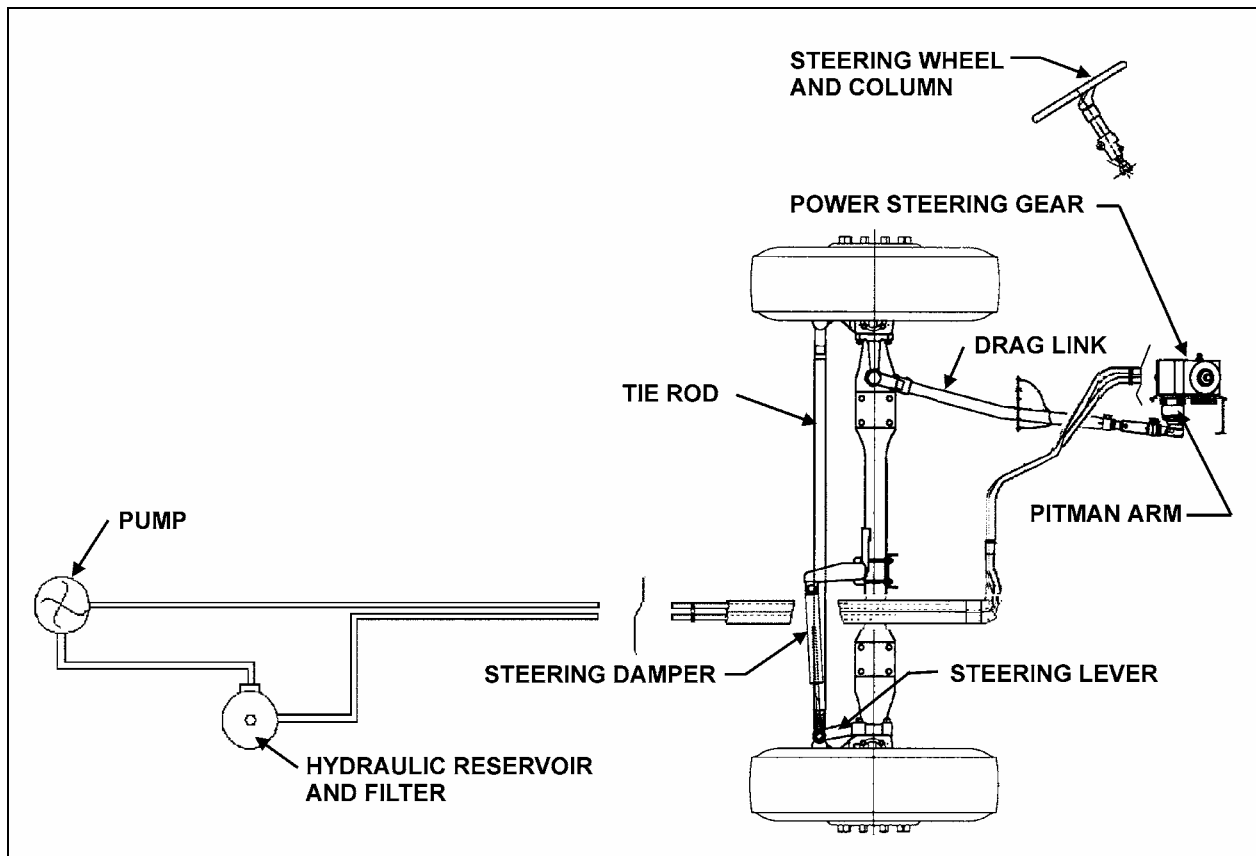

FIGURE 1: STEERING SYSTEM AXLE SETUP

14041

2. POWER STEERING GEAR

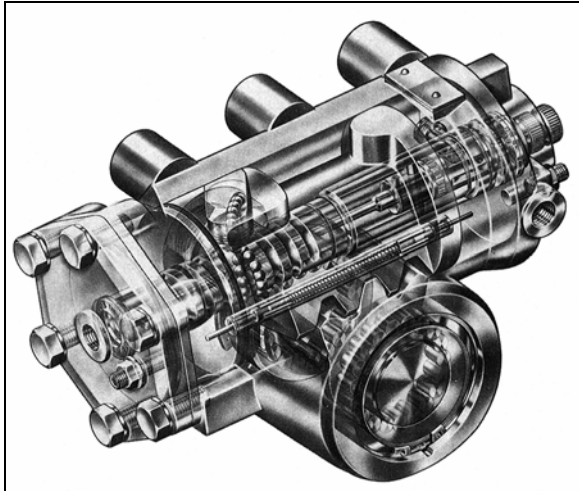

FIGURE 2: POWER STEERING GEAR

14035

2.1 DESCRIPTION

The power steering gear is located in the lower part of front service compartment (Figs. 2 & 3). The housing of the ZF-Servocom contains a control valve, working cylinder and a complete mechanical steering gear. The pressure oil for the steering is delivered by a motor-driven oil pump which is supplied with oil from an oil tank.

The housing is designed as a cylinder for the piston, which converts the rotation of the steering shaft and the worm into an axial movement and transfers this to the steering worm sector shaft. The serration of the sector shaft is straight-cut with a high surface quality in such a way that it is only possible to set a unique setting without play on installation in the straight-ahead driving area by means of the two eccentrically designed lateral housing covers.

The piston and worm are connected via a ball chain. When the worm is turned, the balls are collected by a circulating pipe at one end of the chain and fed in again at the other end, thus producing an endless ball chain.

The control valve consists of the valve slide in a needle bearing in the worm, with six control grooves on the circumference and the control sleeve on the worm, which also has six control grooves. The valve slide, designed with steering shaft connection, turns together with the worm as the steering wheel is turned.

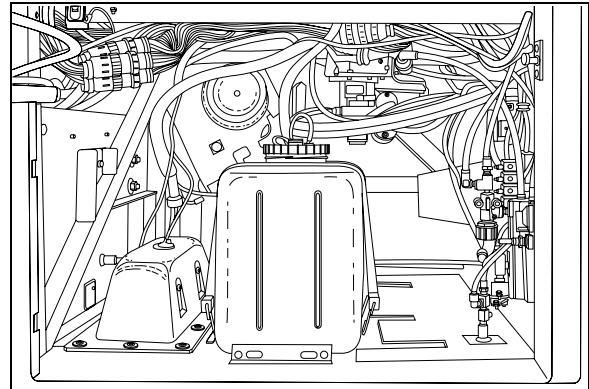

FIGURE 3: FRONT SERVICE COMPARTMENT

14050

A torsion bar, which is pinned with the valve slide and the worm, keeps the control valve in the neutral position as long as no opposing force is applied to the steering wheel. The steering housing contains a pressure relief valve, which limits the discharge pressure of the oil pump to the maximum value required. A replenishing valve can also be used, through which oil is sucked from the return if steering is not hydraulically boosted.

Compared with constant ratio, steering versions with variable ratio are more directly designed in the center area than outside the center area. The resulting smaller steering corrections benefit steering behavior in straight-ahead driving. At the same time, the indirect transmission means that there is a higher hydraulic torque available at the steering arm in parking movement. If the hydraulic assistance fails, the operating forces on the steering wheel are correspondingly lower in this area. This is achieved through a piston/steering worm sector shaft serration with differing modulus and angle of pressure.

Upon transfer of a torque from the steering shaft to the worm, or vice versa, the torsion bar is deformed in the elastic area so that there is torsion between the valve slide and the control sleeve. When the steering wheel is released, the torsion bar ensures that the valve is returned to the neutral position.

Refer to the *"ZF-SERVOCOM Repair Manual"* and *"ZF-SERVOCOM Operating, Servicing /Maintenance and Inspection Instructions"* annexed to this section for the functional aspects and maintenance procedure of the steering gear.

Note: Also available is the ZF-Servocomtronic, which provides variable assistance in function of speed.

2.2 POWER STEERING GEAR REMOVAL

Warning: The steering gearbox weighs approximately 100 lbs (45 kg) dry. Exercise caution when maneuvering.

1. Put a container into place, then disconnect both the inlet and outlet hoses from the power steering gear. Cover fittings to prevent fluid contamination.
2. Mark both the pitman arm and sector shaft with a line, then remove pitman arm. Refer to "11.1 Pitman Arm Removal" procedure.
3. Mark both the steering shaft universal joint yoke and steering gear input shaft with a line, then disconnect universal joint.
4. Unscrew and remove the power steering gear.

2.3 POWER STEERING GEAR INSTALLATION

Reverse "Power Steering Gear Removal" procedure paying particular attention to the following:

1. Tighten fasteners as recommended under paragraph 14: "TORQUE SPECIFICATIONS".
2. Bleed air from the system as per step 3, next.

3. BLEEDING POWER STEERING HYDRAULIC SYSTEM

To bleed the power steering hydraulic system, refer to the "ZF-SERVOCOM REPAIR MANUAL" annexed to this section, under heading "SETTING AND FUNCTIONAL TEST".

4. HYDRAULIC PRESSURE TEST

Perform a pressure test as outlined in the "ZF-SERVOCOM REPAIR MANUAL" annexed to this section under heading "SETTING AND FUNCTIONAL TEST".

5. TROUBLESHOOTING

Perform troubleshooting of the steering gear as outlined in the "ZF-SERVOCOM REPAIR MANUAL", the "ZF-SERVOCOM Operating, Servicing/Maintenance and Inspection Instructions" and the "TRW - POWER STEERING PUMP SERVICE MANUAL" and the "TRW - CHART YOUR WAY TO EASY STEERING" guide annexed to this section.

Note: For vehicles equipped with ZF-SERVOCOMTRONIC unit, refer to the supplement to the repair manual ZF-SERVOCOM.

6. POWER STEERING HYDRAULIC PUMP

6.1 DESCRIPTION

The power steering pump is a vane type, gear driven, hydraulic unit which supplies hydraulic pressure for the operation of the steering gear. The pump is mounted on the engine, on the crankshaft pulley's R.H. side.

6.2 REMOVAL AND INSTALLATION

The pump is accessible through the engine compartment rear door.

To remove the pump, proceed as follows:

1. Put an empty container directly below pump, then disconnect both the inlet and outlet hoses from the pump. Block fitting cavities to prevent fluid contamination.
2. Remove the two (2) mounting screws, then slowly pry out the pump.
3. Remove and discard gasket.

Caution: Inspect the drive coupling thoroughly, and replace if necessary (the drive coupling is a fiber component located between the engine and the pump).

For pump installation, reverse the removal procedure paying particular attention to the following:

Caution: Ensure that drive coupling is correctly positioned before reinstalling the pump.

Section 14: STEERING

1. Install a new gasket (Prévost P/N 510488).
2. Bleed air from the system as per step 3, "Bleeding Power Steering Hydraulic System".

6.3 MAINTENANCE

Refer to the "ZF-SERVOCOM REPAIR MANUAL" and the "TRW - POWER STEERING PUMP SERVICE MANUAL" annexed to this section.

7. STEERING WHEEL

7.1 REMOVAL

1. Set the battery master switch located in the R.H. side rear service compartment, or in the engine compartment to the "OFF" position.
2. Using a tool, such as a small flat head screwdriver, pry off the air horn cap.
3. Loosen the small screw in center of cap and the other retaining the black wire, then disconnect the white terminal. Remove horn cap.
4. Loosen and remove the steering wheel nut.
5. Using a suitable puller, remove the steering wheel.

7.2 INSTALLATION

To install, reverse the removal procedure. Torque steering wheel nut to 35-45 lbf•ft (47-60 N•m).

8. STEERING COLUMN

8.1 REMOVAL

To disassemble the steering column from system, refer to Figure 4. The steering column has no lubrication points. The lower steering column U-joint is easily accessible through the front service compartment. The upper steering column U-joint and the steering slip joint are accessible from the front driver's area. To access these joints, proceed as follows:

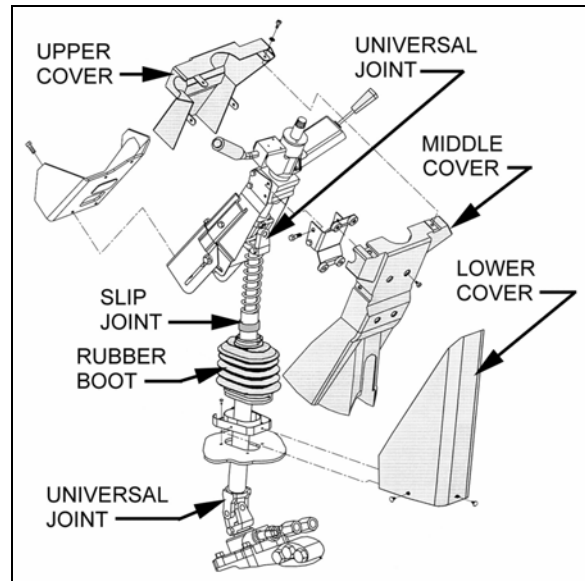

FIGURE 4: STEERING COLUMN

14040

1. From the front driver's compartment area, remove the three plastic fasteners on steering column lower cover. Remove the lower cover (Fig. 4).
2. Unscrew the four retaining screws on steering column middle cover.
3. Unscrew the four retaining screws fixing steering column upper cover to middle cover. Remove the steering column middle and upper covers.
4. Position the steering wheel in order to gain access to the joints.

9. TURNING ANGLE ADJUSTMENT

The maximum turning angle is set through two (2) steering stop screws installed on the axle center. Steering stop screws are factory adjusted to accommodate the chassis design, and therefore, do not require adjustment on new vehicles. However, these should be checked and adjusted if necessary, any time a steering system component is repaired, disassembled or adjusted. Refer to section 10 "FRONT AXLE" under heading "6.4 TURNING ANGLE ADJUSTMENT".

Caution: To prevent the steering damper from interfering with the adjustment of turning angles,

make sure its fixing bracket is at correct location on the axle (refer to "12.2 Steering Stabilizer Cylinder (Damper)).

Hydraulic Stop

Caution: Reduce or shut off the power steering hydraulic pressure before the boss on the axle touches the stop screw. If not, the components of the front axle will be damaged (refer to "ZF-SERVOCOM REPAIR MANUAL" and "ZF-SERVOCOM Operating, Servicing/Maintenance and Inspection Instructions" annexed to this section, under heading "SETTING THE STEERING LIMITER").

Caution: Never maintain the relief pressure for more than 5 seconds, since damage to the power steering pump may occur.

10. STEERING LINKAGE ADJUSTMENT

The steering linkage includes the pitman arm, drag link, steering arm, tie rod arms and tie rod.

Perform lubrication according to "DANA SPICER NDS Axles Lubrication and Maintenance" annexed to section 10 "FRONT AXLE".

Drag link ends are provided with grease fittings. Under normal conditions, these should be serviced every 6,250 miles (10 000 km). Refer to section 24 "LUBRICATION".

Steering linkage pivot points should be checked each time they are lubricated. Looseness can be visually detected while rotating the steering wheel in both directions. Replace defective parts.

Caution: Front wheel alignment should be checked and adjusted if necessary, any time a component of the steering system is repaired, disassembled or adjusted. Refer to section 10 "FRONT AXLE" under heading 6. "FRONT WHEEL ALIGNMENT".

11. PITMAN ARM

11.1 REMOVAL

1. Remove cotter pin, nut and washers from drag link ball stud at pitman arm.

2. Disconnect drag link from pitman arm, using jaw style pullers (pressure screw type).

Warning: Always wear approved eye protection when operating pullers.

Caution: Do not drive (hammer in) pitman arm on or off pitman shaft as this can damage the steering gear.

Caution: Heating of components to aid in disassembly is not allowed because it has a detrimental effect on axle components and steering linkages.

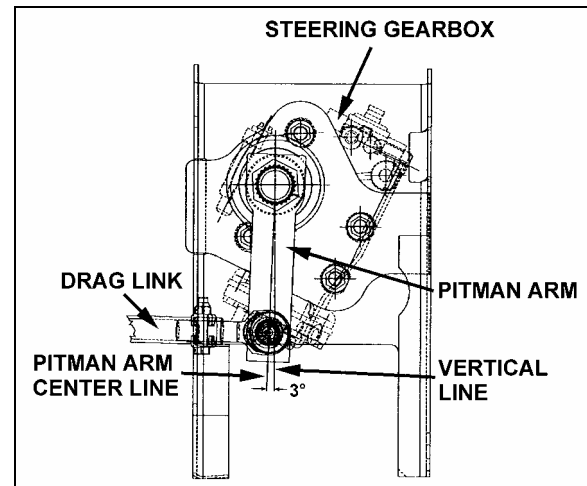

FIGURE 5: PITMAN ARM ADJUSTMENT

14052

3. Using a cold chisel, undo punch mark that locks fixing nut to the pitman arm.
4. Remove pitman arm fixing nut.
5. Check the radial position of the pitman arm in relation to the sector shaft prior to removal of pitman arm.
6. Add reference marks to the arm and shaft if necessary to ensure correct alignment at reassembly.
7. You must use a puller to remove pitman arm.

Section 14: STEERING

11.2 INSTALLATION

1. Position pitman arm on sector gear shaft with reference marks aligned.
2. Install fixing nut (Prévost #661050). Tighten nut to 400-450 Ft-lbs (545-610 Nm).

Note: Use a new nut if the previously removed nut was punched.

3. Lock nut with sector shaft using a punch mark into the groove (refer to figure 6).

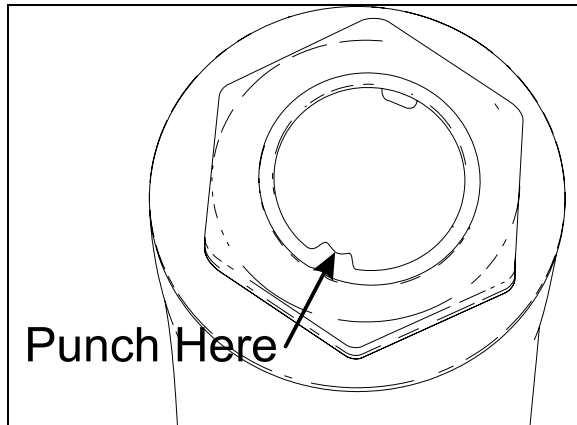

FIGURE 6: FIXING NUT PUNCH MARK

16098

4. Connect drag link to pitman arm while ensuring that rubber stabilizer is in place on the rod end. Install washers. Tighten nut to 160-215 Ft-lbs (220-290 Nm). Afterwards, install a new cotter pin.

Caution: Input shaft marks must be aligned before adjusting pitman arm.

11.3 ADJUSTMENT

1. Disconnect the drag link from pitman arm. Center steering wheel by dividing the total number of steering wheel turns in two. Scribe a reference mark on steering gearbox at the center previously determined.
2. Using a protractor, check the angle of the pitman arm (refer to Fig. 5 for details).
3. The pitman arm should be adjusted to an angle of 3° in relation with the vertical axis (towards rear of vehicle). If not, unscrew and remove fixing nut. Remove the pitman arm according to the procedure outlined under previous heading "Pitman arm removal". Adjust to the proper angle.

4. When adjustment is achieved, replace fixing nut and torque to 400-450 Ft-lbs (545-610 Nm).

12. MAINTENANCE

The power steering system requires little maintenance. However, the system should be kept clean to ensure maximum operating performance and troublefree service. Periodic inspections should also be made to check for leakage and all parts for damage or distortion. Insure all fasteners are tight (see "14. SPECIFICATIONS" for recommended tightening torques).

When the slightest evidence of dirt, sludge or water is discovered in the system, disconnect fluid lines at the power steering gear to drain the system. Drain and refill the system with "Dexron-II or Dexron-III" automatic transmission oil.

Air in the hydraulic system will cause spongy action and noisy operation. When a hose has been disconnected or when fluid has been lost for any reason, the system must be bled. Bleed system as outlined under heading 3: "BLEEDING POWER STEERING HYDRAULIC SYSTEM".

Warning: Do not operate the pump without fluid in the power steering fluid reservoir.

If the steering linkage between the steering gear and the two front wheels is not properly adjusted, or if it is bent, twisted or worn, the steering of the vehicle will be seriously impaired. Whenever a steering linkage part is repaired, replaced or adjusted, steering geometry and front wheel alignment must be checked and necessary corrections made. Refer to section 10 "FRONT AXLE" under heading 6: "FRONT WHEEL ALIGNMENT".

At regular lubrication intervals, the steering linkage should be thoroughly inspected for worn or loose components.

After the vehicle has been operated continually and high mileage figures have been reached, overhaul of the various steering units will be required. General overhaul procedure normally requires removal of the entire assembly, cleaning and inspection of all parts and final assembly. Careful inspection of all parts during overhaul is very important and must not be neglected. Lubrication fittings must all be cleaned before applying lubricant. Moreover, always be sure the

equipment used in applying lubricant is clean. Every precaution should be taken to prevent entry of dirt, grit, lint or other foreign matter into lubricant containers. Replace fittings that have become broken or damaged. Lubrication intervals, as well as the recommended lubricants for the steering components, are given in the "LUBRICATION AND SERVICING SCHEDULE" in Section 24 of this manual. The intervals given in the schedule are recommended for normal service. More frequent intervals may be required under severe operating conditions.

12.1 POWER STEERING RESERVOIR AND FILTER

The power steering reservoir is located on R.H. side of engine compartment, on front wall and accessible through the engine compartment R.H. side door. (Fig. 7).

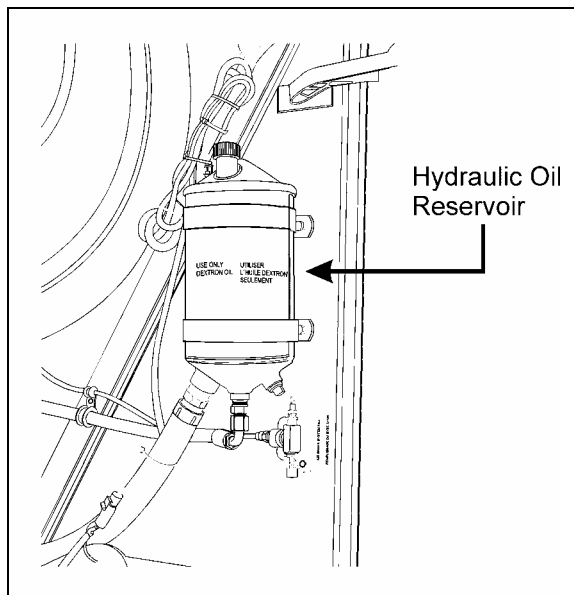

FIGURE 7: HYDRAULIC FLUID RESERVOIR LOCATION
14043

At regular intervals, fluid level should be checked in the reservoir and filter assembly. Furthermore, the oil filter cartridge element in the power steering reservoir should be replaced every 50,000 miles (80 000 km) or once a year, whichever comes first.

12.1.1 Oil Level Check Procedure

1. Stop engine. Open engine compartment R.H. side door.
2. Unscrew and remove the dipstick located on top of reservoir and wipe with a clean rag.
3. Insert dipstick in reservoir. Remove it again to check fluid level (Fig. 8).
4. Adjust level to "FULL" mark using proper dipstick side depending on fluid temperature, use "Dexron-II or Dexron-III" automatic transmission oil.
5. Reinsert and tighten the dipstick.

12.1.2 Filter Replacement

1. Unscrew and remove the cover nut located on top of the power steering reservoir.
2. Remove the reservoir cover and the gasket.
3. Remove the retaining spring and finally the filter cartridge element.

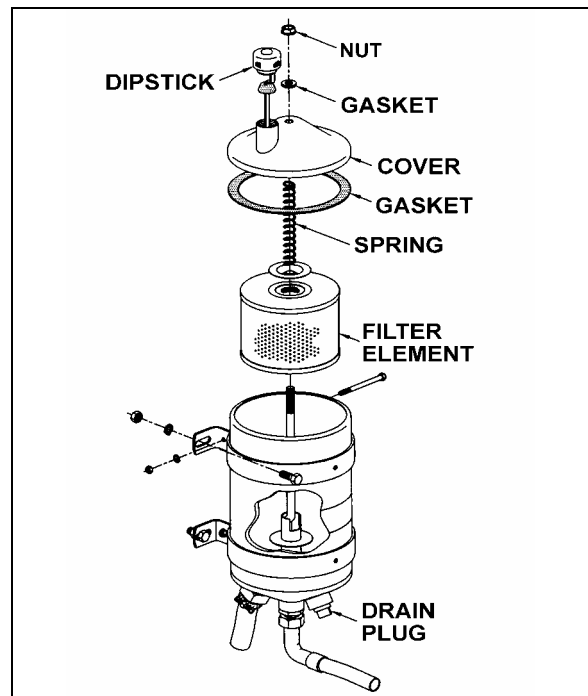

FIGURE 8: POWER STEERING FLUID RESERVOIR 14018A

Section 14: STEERING

12.2 STEERING STABILIZER CYLINDER (DAMPER)

The steering damper is located on R.H. side, at back of front axle (Fig.9).

The cylinder is nonadjustable and non-repairable. Check for oil leaks or lack of resistance. Disconnect the cylinder from axle, then carefully attempt to extend and collapse it manually.

The rod end (ball joint) is provided with a grease fitting. Under normal conditions, it should be serviced every 6,250 miles (10 000 km) or twice a year, whichever comes first. Good quality lithium-base grease NLGI No. 1 and 2 are recommended (refer to section 24 "LUBRICATION"). Check the ball joint for wear, and replace if necessary.

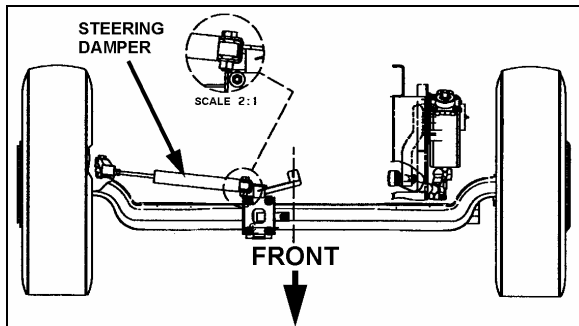

FIGURE 9: STEERING STABILIZER (DAMPER) 14053

12.3 DRAG LINK

Lubricate the fittings every 6,250 miles (10 000 km) or twice a year, whichever comes first. Good quality lithium-base grease NLGI No. 1 and 2 are recommended (refer to section 24 "LUBRICATION").

12.4 POWER STEERING HYDRAULIC PUMP

For maintenance of the power steering hydraulic pump, refer to the "TRW - POWER STEERING PUMP SERVICE MANUAL" annexed to this section.

13. DRIVING TIPS

In order to maximize power steering pump service life, do not attempt to turn the steering wheel when the vehicle is stationary, and especially when service brakes are applied (wheel locking will oppose the effect of steering geometry which tends to make the front wheels rotate in opposite directions).

Persisting in turning, or maintaining the steering wheel with an extra effort, could make the hydraulic system work at the relief pressure, and consequently, cause the hydraulic fluid to become overheated.

Caution: Never maintain the hydraulic system at the relief pressure for longer than 5/10 seconds to avoid damaging the power steering pump.

Note: Unequal or low tire pressure, oversize tires, and vehicle overloading are some of the causes that may increase steering effort.

14. TORQUE SPECIFICATIONS

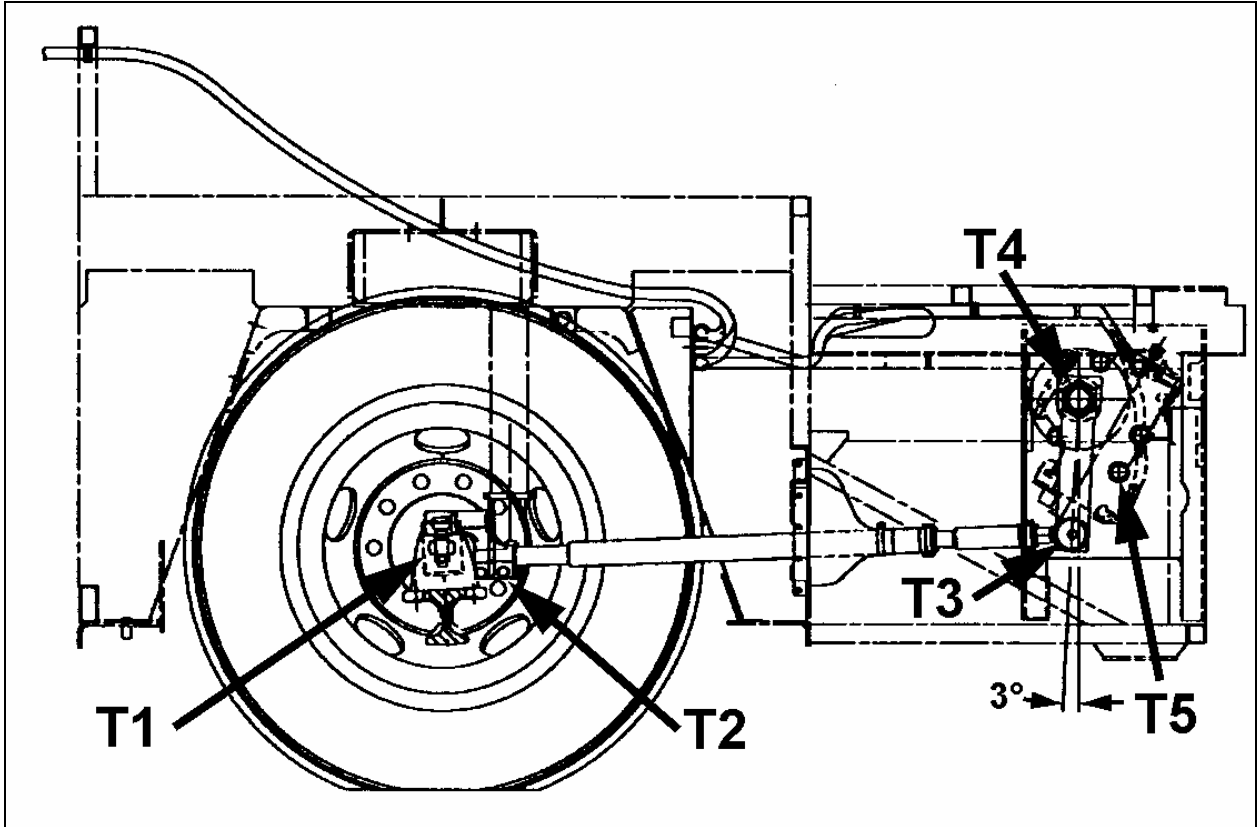

FIGURE 10: DRAG LINK COMPONENTS

14054

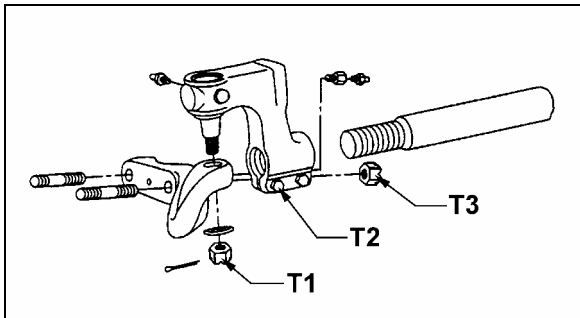

FIGURE 11: TIE ROD END

14036

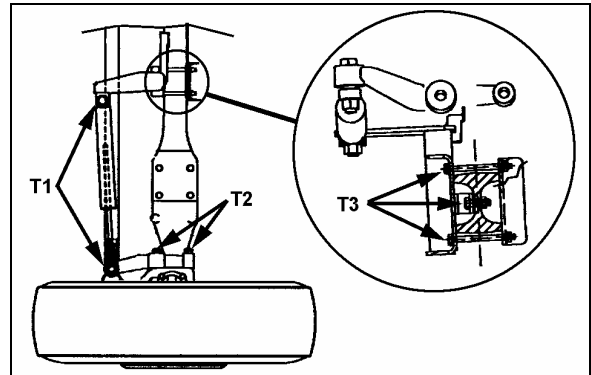

FIGURE 12: FRONT AXLE COMPONENTS

14055

Section 14: STEERING

DRY TORQUES			
Description	Reference	Ft-lbs	Nm
Drag Link End Stud Nut (on steering arm)	Fig. 10, T1	160-300	220-410
Drag Link End Pinch Bolt Nuts	Fig. 10, T2	50-65	70-90
Drag Link End Stud Nut (on pitman arm)	Fig. 10, T3	160-215	220-290
Pitman Arm Fixing Nut	Fig. 10, T4	400-450	545-610
Tie Rod End Screw Pin Nut	Fig. 11, T1	100-175	135-240
Tie Rod End Pinch bolt Nuts	Fig. 11, T2	65-75	90-100
Lower Lever Stud Nuts	Fig.11, T3	190-275	260-375
Steering Stabilizer (damper) Fixing Nuts	Fig. 12, T1	100-120	135-165
Steering Top Lever Nuts	Fig. 12, T2	150-200	205-275
Steering Damper Mounting Support Nuts	Fig. 12, T3	65-70	90-95

TORQUE (LUBRICATED WITH LOCTITE #242 BLUE)			
Description	Reference	Ft-lbs	Nm
Steering Gear Fixing Bolts (4)	Fig. 10, T5	265-310	360-420

15. SPECIFICATIONS

Power Steering Gear

Make ZF-SERVOCOMTRONIC
 Model 8098
 Supplier number 8098-988-571
 Prevost number 661044
 F.E.W. 16,600 lbs (7 545 kg)
 Pressure rating 2,175 psi (150 Bar)
 Gear ratio (center) 22.2 : 1
 Gear ratio (extremities)..... 26.2 : 1
 Minimum pump flow for 1.5 hwt/sec 4.22 gpm (16 lpm)

Power Steering Gear

Section 14: STEERING

MakeZF-SERVOCOM
Model 8098
Supplier number 8098-988-570
Prevost number 661045
F.E.W. 16,600 lbs (7 545 kg)
Pressure rating 2,175 psi (150 Bar)
Gear ratio (center) 22.2 : 1
Gear ratio (extremities)..... 26.2 : 1
Minimum pump flow for 1.5 hwt/sec 4.22 gpm (16 lpm)

Power Steering Pump

MakeTRW
TypePS Series
Relief valve setting 2,175 psi (14 990 kPa)
Controlled flow rate 4.23 gpm (16 lpm)
Inlet port 1 1/4 NPT
Outlet port 3/4-16 straight thread SAE O' ring boss conn.
Supplier number PS251615L10200
Prevost number 661009
Gasket - Supplier number 23516100
Gasket - Prevost number 510488

Power Steering Reservoir

Make Nelson Muffler
Oil capacity 4 US qts (3.7 liters)
Supplier number 91410A
Prevost number 660982
Make Nelson Muffler
Element filter - Supplier number 83804 E
Element filter - Prevost number 660987

Steering Stabilizer Cylinder (Damper)

MakeArvin
Extended length..... 32.73±0.12"
Collapsed length..... 20.26±0.12"
Stroke..... 12.47±0.12"
Supplier number 651535
Prevost number 660979
Dust cap - Prevost number 660980