

TECHNICAL MANUAL

A 132, AV 110, AV 132II, AV 132II T, AV 133, AV 133 T, AVE 130, AVN 132,
RL 55 EC, RL 75 A, RL 75 A (NLA), RL 75 E, RL 75 EC, RL 75 EC (NLA), RL 82 EC,
RL 85 A, RL 85 A (NLA)
Installation Guidelines

BUSES



Copyright © ZF Friedrichshafen AG

This document is protected by copyright.

Complete or partial reproduction or distribution of this document is not permitted without the approval of ZF Friedrichshafen AG.

Infringements lead to civil and criminal prosecution.

This document is a translation of the German original.

1	Preface	5
1.1	Product designation	6
1.2	Document overview	7
2	Safety Instructions	8
2.1	General safety instructions	8
2.2	Signal words and symbols	10
2.3	Product-specific safety instructions	11
3	Description	12
3.1	Brief product description	12
4	Technical Data	18
4.1	Oil	18
4.1.1	Oil grade	18
4.1.2	Oil purity	18
4.2	Grease	18
4.3	Type plate	19
5	Temperature and Cooling	20
5.1	Permissible oil temperature	20
6	Transport and Storage	21
6.1	Transport	21
6.1.1	General transport instructions	21
6.2	Storage	22
6.2.1	Short-term storage	22
6.2.2	Long-term storage	22
6.3	Corrosion protection and preservation	24
7	Installation conditions	25
7.1	Arrangement in the vehicle	25
7.2	Axle suspension	25
7.2.1	Longitudinal rods and V-rods	25
7.2.2	Shock absorber	28
7.2.3	Air spring	30
7.2.4	Wheel travel limitation	31
7.2.5	Stabilizer bar	32
7.3	Installation conditions for axle type RL	34
7.3.1	Steering geometry	34
7.3.2	Track adjustment	35
7.3.3	Steering linkage and steering spindle	39
7.3.4	Steering stop and steering gear setting	40
7.3.5	Setting the axle geometry	40
7.4	Installation conditions for axle types A, AV, AVN, AVE	43
7.4.1	Spring carrier	43

Table of Contents

7.4.2	Positioning axle in chassis	45
7.4.3	Propshaft	46
7.4.4	Breather system	52
7.4.5	Notes on axle driven by an electric motor	59
7.4.6	Integration of axle AVE 130 into vehicle system	66
7.5	Brake system	66
7.5.1	Brake system design	66
7.5.2	Notes on installation and initial operation of brake system	67
7.5.3	Brake-force distribution	68
7.5.4	Retarder integration into brake system	70
7.5.5	Sensors for the antilock braking system	70
7.5.6	Brake chamber	70
7.5.7	Wear sensing	72
7.6	Wheels	72
7.7	Accessibility	74
7.8	Corrosion protection	74
7.9	Additional brackets	75
7.10	Painting	75
7.11	Subsequent painting	75
7.12	Underbody protection	76
8	Installation	77
8.1	Preparatory activities	77
9	Commissioning	78
9.1	Before initial operation	78
9.1.1	Checking oil level	78
10	Annex	79
10.1	Overview of revisions	79
10.2	Subject index	80
10.3	List of abbreviations	82
11	Attached Documents	83

1 Preface

This Technical Manual is addressed to vehicle manufacturers, body manufacturers and ZF employees and serves as technical guideline.

Object of documentation is a ZF product. State of design according to date of issue.

Illustrations and figures are not drawn to scale; therefore, no conclusions about size and weight can be drawn.

This Technical Manual describes ZF standard applications.

A ZF standard application contains:

- Development of the specification for the ZF product by the vehicle manufacturer or body manufacturer and ZF.
- Documentation by ZF.
- Initial installation.

Customer-specific applications must be agreed in writing with ZF Friedrichshafen AG (hereinafter referred to as "ZF").

ZF Friedrichshafen AG

1.1 Product designation

The product designation is composed of the following:

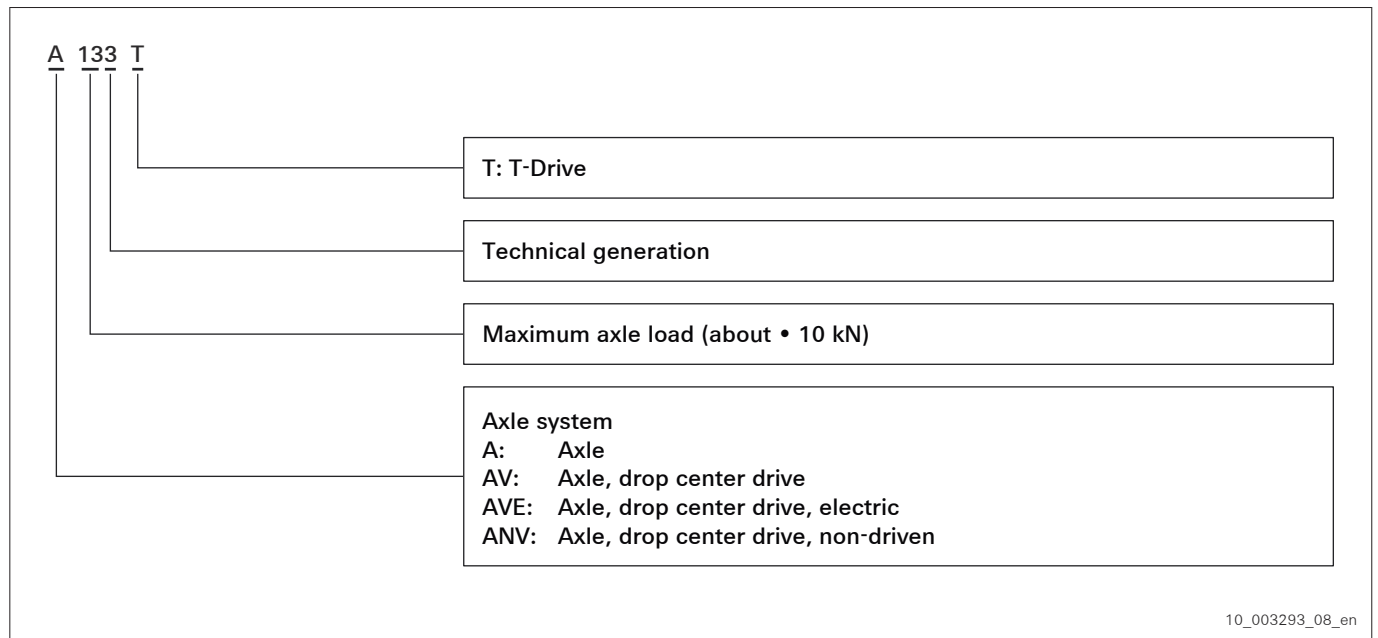

Fig. 1

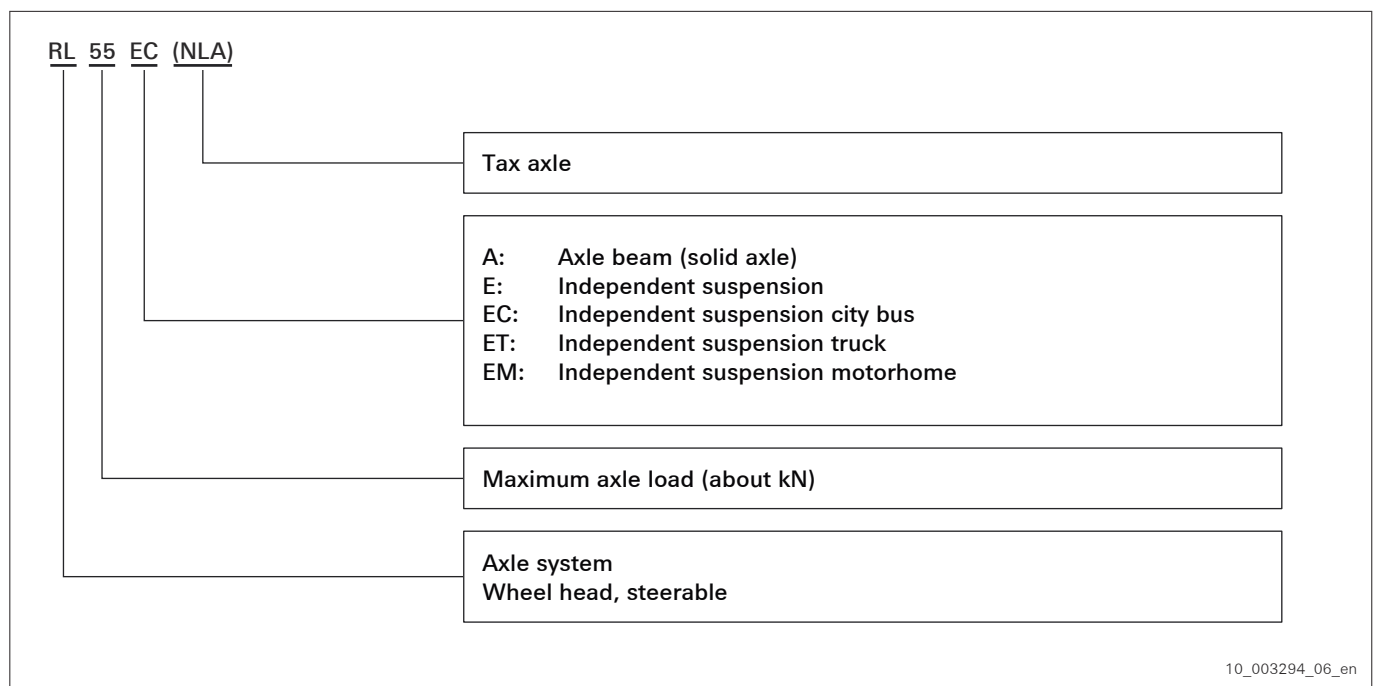

Fig. 2

1.2 Document overview

The specifications listed in these documents must be observed because they are a prerequisite for fault-free operation of the product and for the warranty granted by ZF Friedrichshafen AG. Please speak with your contact if you need binding documents.

Document no.	Designation	Technical information
4472.754.101	Checklist	Checklist for installation
4474.700.135	Installation Instructions	Electric integration AVE 130
5871.207.902	Operating Instructions	A 132
4472.758.101	Operating Instructions	AV 110, AV 133, AV 133 T
5871.214.912	Operating Instructions	AV 132II, AV 132II T
5871.215.902	Operating Instructions	AVE 130
5871.216.902	Operating Instructions	AVN 132
5871.201.922	Operating Instructions	RL 55 EC
5871.197.902	Operating Instructions	RL 75 A, RL 75 A (NLA), RL 75 E, RL 75 EC, EL 75 EC (NLA), RL 82 EC
5871.201.902	Operating Instructions	RL 85 A, RL 85 A (NLA)
5871.207.002	Repair instructions	A 132
4472.751.102	Repair instructions	AV 110
5871.214.102	Repair instructions	AV 132II, AV 132II T
4472.751.101	Repair instructions	AV 133, AV 133 T
5871.215.002	Repair instructions	AVE 130
5871.216.002	Repair instructions	AVN 132
5871.201.202	Repair instructions	RL 55 EC
5871.197.002	Repair instructions	RL 75 A, RL 75 A (NLA), RL 75 E, RL 75 EC, EL 75 EC (NLA), RL 82 EC
5871.201.101	Repair instructions	RL 85 A, RL 85 A (NLA)

Tab. 1

2 Safety Instructions

2.1 General safety instructions

Please read all safety instructions. Failure to comply with safety information and instructions may lead to property damage, serious injuries, or death.

Intended use

The ZF product is designed and produced in line with state-of-the-art technology and is safe to operate. However, this ZF product may pose dangers if improperly used by unauthorized, untrained, and uninstructed specialized staff or if not used according to its intended use.

Repair, assembly, maintenance, and commissioning

Perform repair, assembly, and maintenance work exclusively according to this documentation on hand and other applicable documents paying particular attention to the points mentioned below:

- Work must be performed in a professional manner and according to the technical provisions.
- Work must only be performed by trained, instructed, and authorized specialized staff.
- Only original ZF spare parts may be used.
- Only original ZF accessories may be used.
- Only original ZF special tools may be used.
- Changes and modifications of the ZF product may lead to the expiry of the operator's license, warranty, or guarantee.

In case of damage, immediate action is mandatory in order to restore or guarantee full functionality and safety / operational safety of the ZF product and to minimize the extent of damage.

In case of damage, contact ZF Services and have the following information ready:

- Product type, product parts list number, and serial number
- Total mileage [km]
- Progress of the damage
- Damage pattern

To avoid personal injury and damage to third-party products and the ZF product, this safety information, all valid safety regulations, and legal requirements must be observed.

Country-specific safety, accident prevention, and environmental regulations apply irrespective of the information provided in this document.

Safety-relevant workwear must be worn for all work. Depending on the type of work, additional protective equipment, e.g. protective goggles, protective gloves, hard hat, and apron must be used. The workwear must fit tightly so that it cannot get caught in turning or protruding parts.

After completion of repair, assembly, and maintenance work, as well as inspections, the specialized staff must ensure that the ZF product is once more functioning perfectly and is safe to operate.

Using ZF products

Impermissible superstructures, add-ons, modifications, and changes to the ZF product may affect the ZF product's operational safety.

Unless explicitly permitted, no repair, assembly, and maintenance work may be performed while the engine is running. Secure the engine against an unintentional start and the vehicle against unintentional movements. Attach a "Do not operate" sign which is visible for everyone! Keep uninvolved parties away.

Increased risk of injury in the event of contact with cooled down or heated parts. Only touch parts when wearing suitable protective gloves.

Handling operating supplies and auxiliary materials

Increased risk of injury at contact with heated, cooled down, or caustic operating supplies and auxiliary materials (e.g. lubricants, cleaning agents, nitrogen).

- Prevent skin contact.
- Do not drink.
- Do not inhale vapors.
- Keep away from ignition sources – do not smoke.

Store operating supplies and auxiliary materials in suitable and correctly labeled containers.

Use suitable protective clothing, protective gloves, and protective goggles/face protection.

Pay attention to the manufacturer's regulations and accident prevention regulations.

Immediately seek medical assistance after contact with heated, cooled down, or caustic operating supplies and auxiliary materials.

Environment

Operating supplies and auxiliary materials may not be allowed to enter the soil, groundwater, or sewage system.

- Request material safety data sheets for the corresponding ZF products from your responsible environmental protection authority, and observe them.
- Collect operating supplies and auxiliary materials in a sufficiently large container.
- Dispose of operating supplies and auxiliary materials, waste, containers, soaked cleaning cloths, contaminated filters, etc. in accordance with the regulations of the environmental protection laws.
- Pay attention to the manufacturer's regulations and accident prevention regulations.

When selecting operating supplies and auxiliary materials, pay attention to health risks, environmental compatibility, disposal regulations, and your country-specific opportunities to dispose of such materials properly.

2.2 Signal words and symbols

This document contains particularly highlighted safety instructions which start with one of the following signal words depending on the severity of the danger.

 **DANGER**

DANGER
The signal word DANGER indicates a dangerous situation that, if not prevented, will lead to a severe injury or death.
⇒ Information as to how the danger can be prevented.

 **WARNING**

WARNING
The signal word WARNING indicates a dangerous situation that, if not prevented, can lead to a severe injury or death.
⇒ Information as to how the danger can be prevented.

 **CAUTION**

CAUTION
The signal word CAUTION indicates a dangerous situation that, if not prevented, can lead to a slight or moderate injury.
⇒ Information as to how the danger can be prevented.

NOTICE

The signal word NOTICE indicates a situation that, if not prevented, can lead to property damage.
⇒ Information as to how the property damage can be prevented.

The following symbols are additionally used:

 This symbol refers to additional, safety-relevant information.

 This symbol indicates information concerning special workflows, methods, application of aids, etc.

2.3 Product-specific safety instructions

NOTICE

Possible damage to or failure of ZF product due to improper handling of high-pressure cleaner.

- ⇒ Clean with water only.
- ⇒ The use of cleaning agents is prohibited.
- ⇒ Keep a minimum distance of 1 m between the high-pressure cleaner nozzle and the ZF product.
- ⇒ Do not point the cleaning jet directly at the following components (if available): screw cap of oil dipstick, breather, hose assemblies, shaft sealing rings, seals, electric components, electric control units, cables, plug connections, actuators and sensors.

Description

3 Description

3.1 Brief product description

Axle	System	Drive	Steerable	
A 132	Rear axle system	Driven	No	Single rear drive axle
AV 110	Rear axle system	Driven	No	Portal axle with drop center drive
AV 132II	Rear axle system	Driven	No	Portal axle with drop center drive
AV 132II T	Rear axle system	Driven	No	Portal axle with drop center drive
AV 133	Rear axle system	Driven	No	Portal axle with drop center drive
AV 133 T	Rear axle system	Driven	No	Portal axle with drop center drive
AVE 130	Rear axle system	Driven	No	Electric portal axle with drop center drive, electrically driven
AVN 132	Rear axle system	Non-driven	No	Portal axle
RL 55 EC	Front axle system	Non-driven	Yes	Independent suspension
RL 75 A	Front axle system	Non-driven	Yes	Axle beam
RL 75 A (NLA)	Tag axle	Non-driven	Yes	Axle beam
RL 75 E	Front axle system	Non-driven	Yes	Independent suspension
RL 75 EC	Front axle system	Non-driven	Yes	Independent suspension
EL 75 EC (NLA)	Tag axle	Non-driven	Yes	Independent suspension
RL 82 EC	Front axle system	Non-driven	Yes	Independent suspension
RL 85 A	Front axle system	Non-driven	Yes	Axle beam
RL 85 A (NLA)	Tag axle	Non-driven	Yes	Axle beam

Tab. 2 Overview

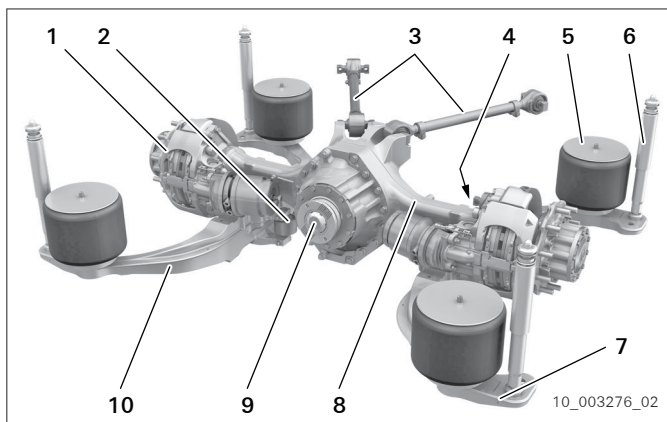

A 132 rear axle system

- 1 Wheel head with brake
- 2 Longitudinal rod
- 3 V-rod
- 4 Stabilizer bar connection
- 5 Air spring
- 6 Shock absorber
- 7 Height leveling connection
- 8 Axle bridge
- 9 Central input
- 10 Spring carrier

Fig. 3 A 132

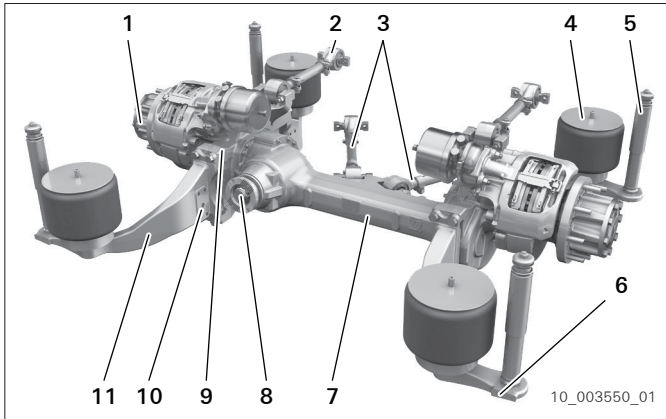

AV 110 rear axle system

- 1 Wheel head with brake
- 2 Longitudinal rod
- 3 V-rod
- 4 Air spring
- 5 Shock absorber
- 6 Height leveling connection
- 7 Axle bridge
- 8 Lateral input
- 9 Drop center drive (portal drive)
- 10 Stabilizer bar connection
- 11 Spring carrier

Fig. 4 AV 110

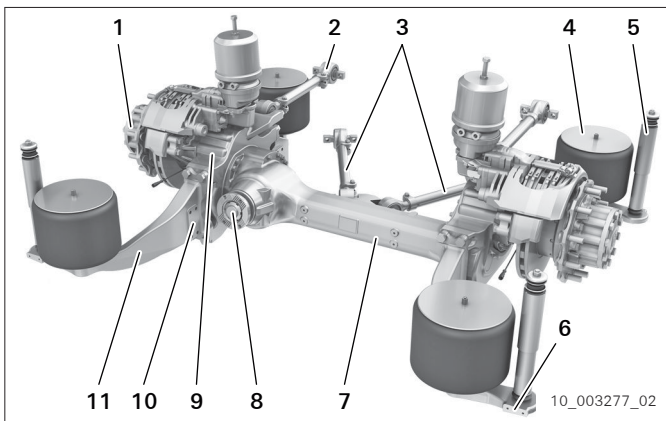

AV 132II, AV 133 rear axle system

- 1 Wheel head with brake
- 2 Longitudinal rod
- 3 V-rod
- 4 Air spring
- 5 Shock absorber
- 6 Height leveling connection
- 7 Axle bridge
- 8 Lateral input
- 9 Drop center drive (portal drive)
- 10 Stabilizer bar connection
- 11 Spring carrier

Fig. 5 AV 132II

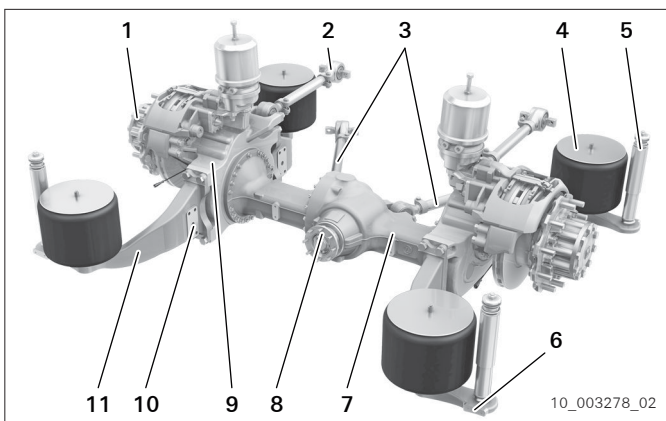

AV 132II T, AV 133 T rear axle system

- 1 Wheel head with brake
- 2 Longitudinal rod
- 3 V-rod
- 4 Air spring
- 5 Shock absorber
- 6 Height leveling connection
- 7 Axle bridge
- 8 Central input
- 9 Drop center drive (portal drive)
- 10 Stabilizer bar connection
- 11 Spring carrier

Fig. 6 AV 132II T

Description

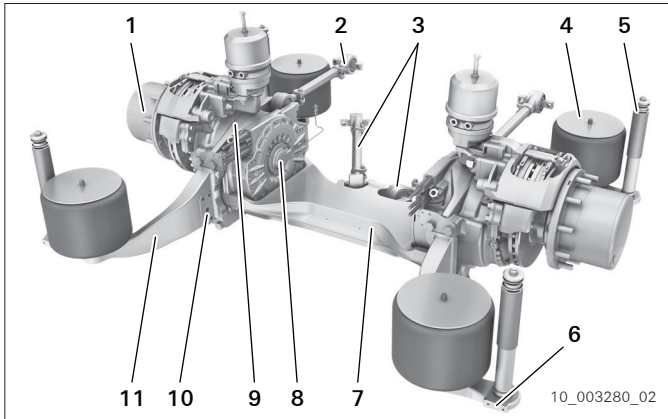

AVE 130 electric portal axle

- 1 Wheel head with brake
- 2 Longitudinal rod
- 3 V-rod
- 4 Air spring
- 5 Shock absorber
- 6 Height leveling connection
- 7 Axle bridge
- 8 Electric drive
- 9 Drop center drive (portal drive)
- 10 Stabilizer bar connection
- 11 Spring carrier

Fig. 7 AVE 130

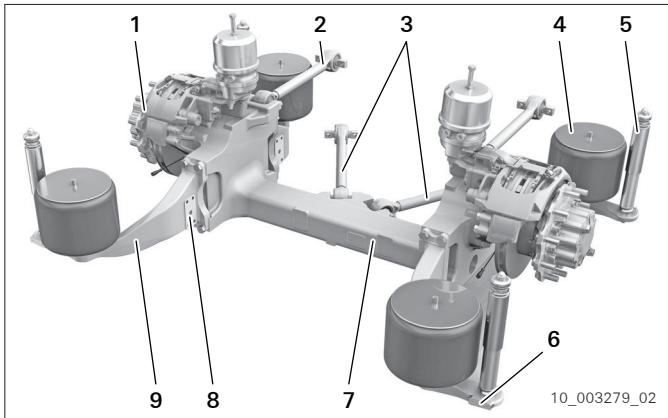

AVN 132 rear axle system

- 1 Wheel head with brake
- 2 Longitudinal rod
- 3 V-rod
- 4 Air spring
- 5 Shock absorber
- 6 Height leveling connection
- 7 Axle bridge
- 8 Stabilizer bar connection
- 9 Spring carrier

Fig. 8 AVN 132

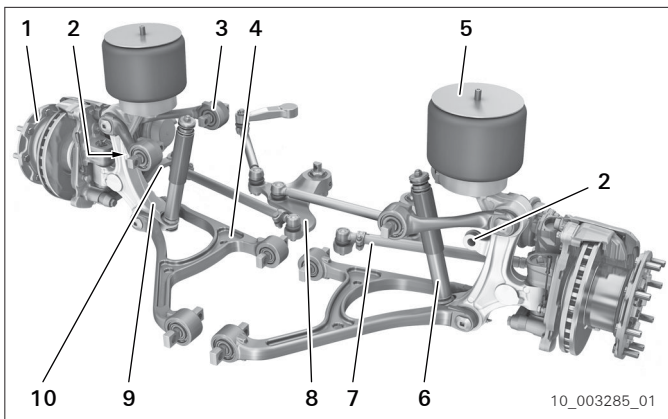

RL 55 EC front axle system

- 1 Wheel head with brake
- 2 Stabilizer bar connection
- 3 Upper control arm
- 4 Lower control arm
- 5 Air spring
- 6 Shock absorber
- 7 Tie rod
- 8 Relay lever
- 9 Steering knuckle carrier
- 10 Track lever

Fig. 9 RL 55 EC

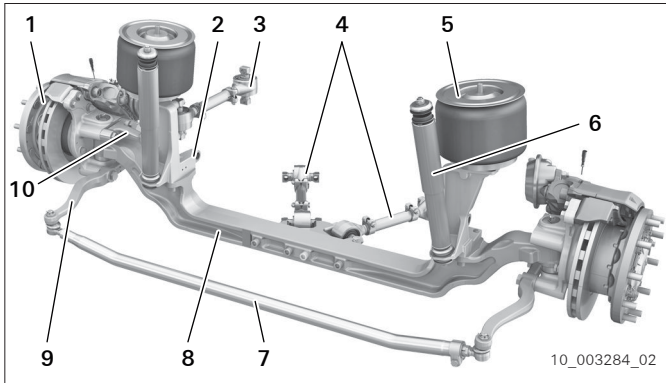

Fig. 10 RL 75 A

RL 75 A front axle system

- 1 Wheel head with brake
- 2 Stabilizer bar connection
- 3 Longitudinal rod
- 4 V-rod
- 5 Air spring
- 6 Shock absorber
- 7 Tie rod
- 8 Axle beam
- 9 Track lever
- 10 Steering lever

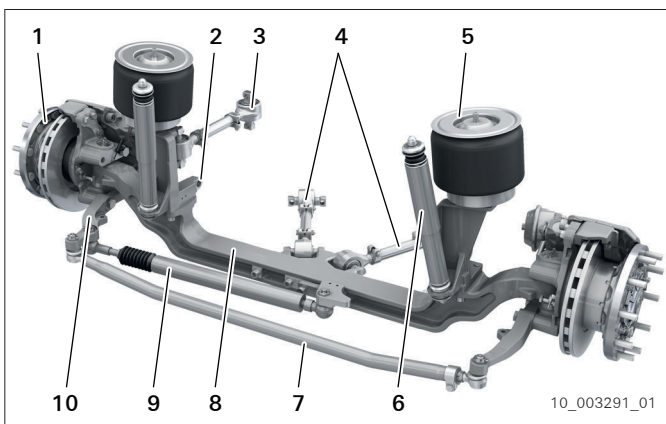

Fig. 11 RL 75 A (NLA) active

Tag axles RL 75 A (NLA) active, RL 85 A (NLA) active

- 1 Wheel head with brake
- 2 Stabilizer bar connection
- 3 Longitudinal rod
- 4 V-rod
- 5 Air spring
- 6 Shock absorber
- 7 Tie rod
- 8 Axle beam
- 9 Hydraulic steering cylinder
- 10 Track lever

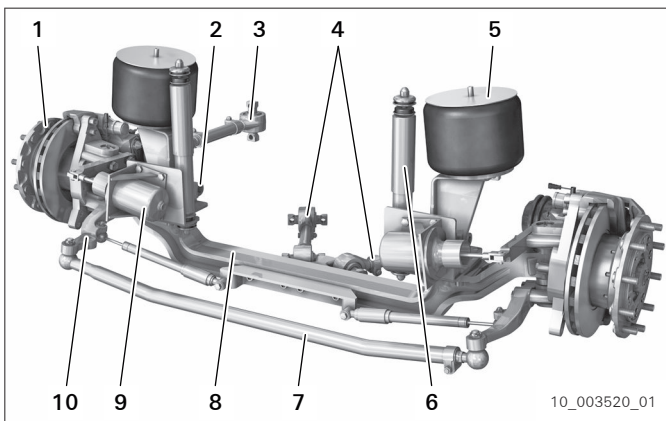
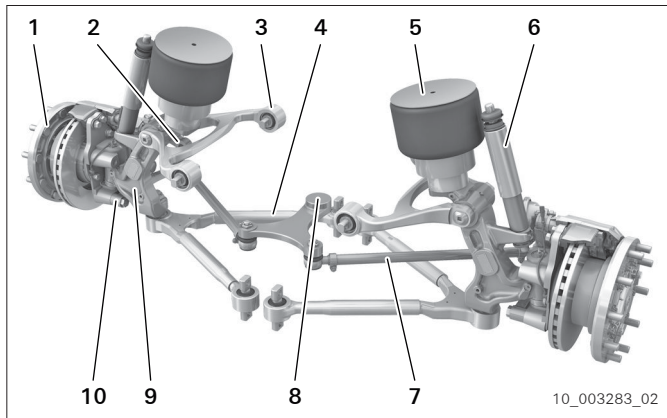

Fig. 12 RL 85 A (NLA) passive

Tag axles RL 75 A (NLA) passive, RL 85 A (NLA) passive

- 1 Wheel head with brake
- 2 Stabilizer bar connection
- 3 Longitudinal rod
- 4 V-rod
- 5 Air spring
- 6 Shock absorber
- 7 Tie rod
- 8 Axle beam
- 9 Pneumatic locking cylinder
- 10 Track lever

Description



RL 75 E front axle system

- 1 Wheel head with brake
- 2 Stabilizer bar connection
- 3 Upper control arm
- 4 Lower control arm
- 5 Air spring
- 6 Shock absorber
- 7 Tie rod
- 8 Pitman arm
- 9 Steering knuckle carrier
- 10 Track lever

Fig. 13 RL 75 E

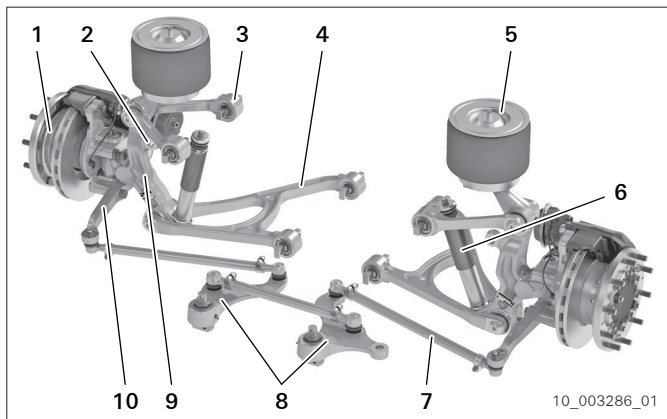

RL 75 EC, RL 82 EC front axle system

- 1 Wheel head with brake
- 2 Stabilizer bar connection
- 3 Upper control arm
- 4 Lower control arm
- 5 Air spring
- 6 Shock absorber
- 7 Tie rod
- 8 Relay lever
- 9 Steering knuckle carrier
- 10 Track lever

Fig. 14 RL 75 EC

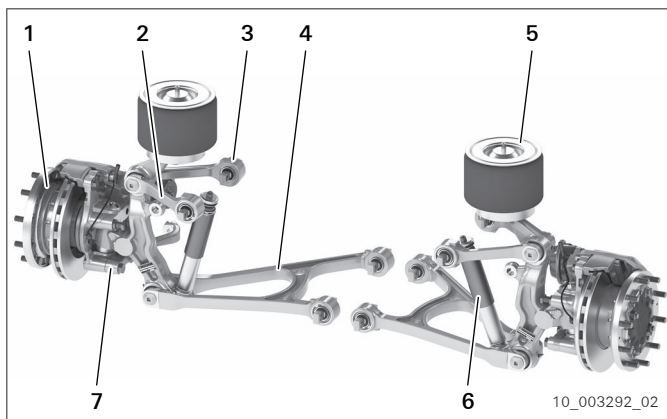

RL 75 EC (NLA) tag axle

- 1 Wheel head with brake
- 2 Stabilizer bar connection
- 3 Upper control arm
- 4 Lower control arm
- 5 Air spring
- 6 Shock absorber
- 7 Track lever

Fig. 15 RL 75 EC (NLA)

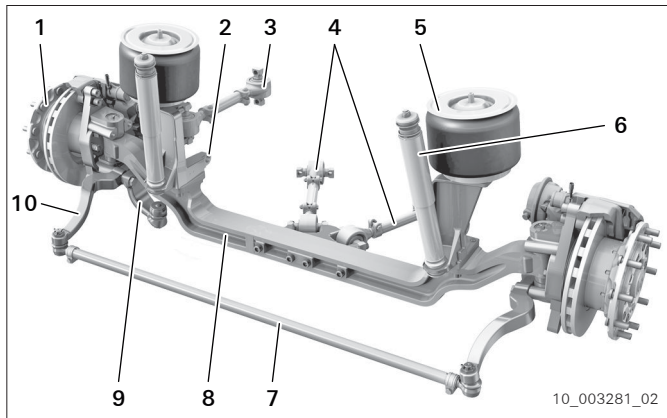
**RL 85 A front axle system**

- 1 Wheel head with brake
- 2 Stabilizer bar connection
- 3 Longitudinal rod
- 4 V-rod
- 5 Air spring
- 6 Shock absorber
- 7 Tie rod
- 8 Axle beam
- 9 Steering lever
- 10 Track lever

Fig. 16 RL 85 A

4 Technical Data

On demand, you can obtain the axle specification (data sheet) from your contact.

4.1 Oil

4.1.1 Oil grade

NOTICE

Damage to ZF product due to incorrect oil possible.

⇒ Only use oils listed in the valid ZF List of Lubricants.



Observe the information on the type plate.

Oils approved and listed in the ZF List of Lubricants are binding: **TE-ML 12**.

The latest ZF List of Lubricants can be obtained from all ZF Service Centers and viewed at www.zf.com.

4.1.2 Oil purity

The oil must not contain any visible solid impurities.

4.2 Grease

NOTICE

Damage to ZF product due to incorrect grease possible.

⇒ Only use greases listed in the valid ZF List of Lubricants.

Greases approved and listed in the ZF List of Lubricants are binding: **TE-ML 12**.

The latest ZF List of Lubricants can be obtained from all ZF Service Centers and viewed at www.zf.com.

4.3 Type plate

Position of the type plate

Axle	Number of type plates	Position of the type plate
A 132	2	Axle bridge, differential
AV 110, AV 132II, AV 132II T, AV 133, AV 133 T, AVN 132	1	Axle bridge
AVE 130	2	Left wheel head, right wheel head
RL 55 EC, RL 75 E, RL 75 EC, RL 75 EC (NLA), RL 82 EC	2	Left steering knuckle carrier, right steering knuckle carrier
RL 75 A, RL 75 A (NLA), RL 85 A, RL 85 A (NLA)	1	Axle beam

Tab. 3

Type plate for axles A 132, AV 110, AV 132II, AV 132II T, AV 133, AV 133 T, AVE 130, AVN 132

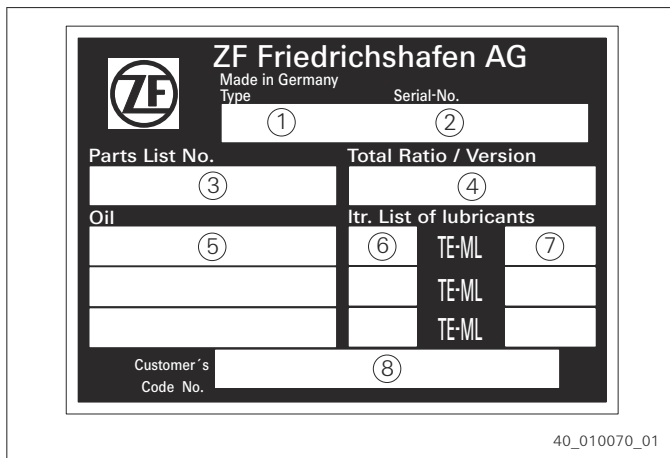

- 1 Product designation
- 2 Serial number
- 3 Parts list number
- 4 Transmission ratio
- 5 Oil specification
- 6 Approx. oil quantity of initial filling
- 7 Number of List of Lubricants
- 8 Customer number if known to ZF

The following data should always be quoted when making inquiries or undertaking repairs: 1, 2, 3

Fig. 17 Type plate

Type plate for axles RL 55 EC, RL 75 A, RL 75 E, RL 75 EC, RL 82 EC, RL 85 A, RL 75 A (NLA), RL 85 A (NLA), RL 75 EC (NLA)

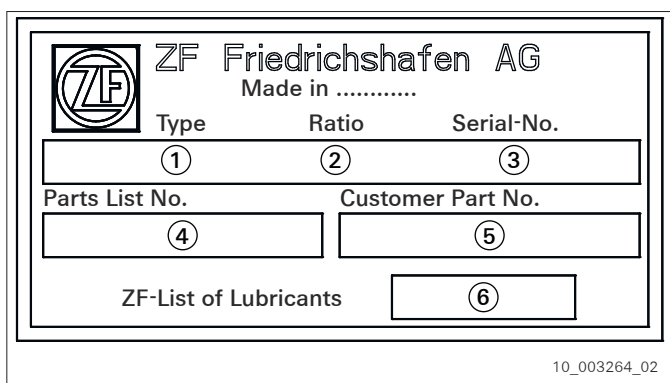

- 1 Product designation
- 2 Ratio
- 3 Serial number
- 4 Parts list number
- 5 Customer number if known to ZF
- 6 Number of List of Lubricants

The following data should always be quoted when making inquiries or undertaking repairs: 1, 3, 4

Fig. 18 Type plate

5 Temperature and Cooling

5.1 Permissible oil temperature

The following applies for axles A 132, AV 110, AV 132II, AV 132II T, AV 133, AV 133 T, AVE 130:

The vehicle manufacturer shall ensure in every driving condition that the oil temperature is always below the limit values stated in the following:

- Maximum continuous temperature: 115°C
- Maximum short-term peak temperature: 120°C

When applied in a hot country, observe shorter oil change intervals according to ZF List of Lubricants TE-ML 12.¹⁾ A cooling system to cool the axle might be required on demand. The latest ZF List of Lubricants can be obtained from all ZF Service Centers and viewed at www.zf.com.

If the measured oil temperature is higher than the limit value, the vehicle manufacturer must take measures to reduce the oil temperature.

Possible reasons for too high oil temperatures are:

- Heat impact from exhaust system and other heat sources.
- No air exchange with axle environment possible.
- Air circulation too low to cool the axle.
- Cooling capacity for axle AVE 130 too low.
- Application in a hot country.

The following measures might be required:

- Protect axle from heat impact from exhaust system and other heat sources. If the distance is too small, fit suitable shields.
- Ensure sufficient air circulation by means of louvers and air ducts.
- Comply with provisions for cooling system of axle AVE 130 (*refer to Installation Instructions 4474.700.135*).
- Install cooling system.



The vehicle manufacturer is responsible for designing the cooling system.

A high oil temperature reduces the axle's service life.

¹⁾ Conditions for application in a hot country, refer to List of Lubricants TE-ML 12.

6 Transport and Storage

6.1 Transport

6.1.1 General transport instructions

WARNING

Risk of injury due to uncontrolled motion of the load.

Death or serious injury possible.

- ⇒ Only use the suspension points intended for transportation purposes.
- ⇒ Only use secure, permitted, and tested means of transport, chain hoist, and lifting equipment with sufficient load capacity and suitable lifting technology.
- ⇒ Ensure that lifting equipment such as ropes and belts are not in contact with sharp edges and are not knotted or twisted.
- ⇒ Properly attach lifting appliances to load.
- ⇒ Observe the load's center of gravity! The crane hook must be located above the load's center of gravity.
- ⇒ Lift load slowly and observe whether the load tilts or swivels out laterally. If required, immediately put down load and modify attachment.
- ⇒ Keep distance.
- ⇒ Do not walk under suspended loads.
- ⇒ Only ever move load under supervision.

NOTICE

Possible damage to ZF product due to inappropriate transport.

- ⇒ The ZF product must be protected from damage during transport.



Observe safety instructions for handling ZF products (*refer to section General safety instructions*).

- The ZF product is delivered on a special load carrier.
- Secure the load carrier to the transport vehicle using suitable devices.
- Protect the ZF product against dirt, moisture and damage by means of suitable covers and load carriers.
- Do not set down or store the load carrier with the ZF product outdoors.
- Immediately notify ZF of transport damage.
- Only use permitted means of transport, lifting tools with sufficient load capacity and suitable lifting technology.



Observe the general transport instructions also for return deliveries of the ZF product to ZF. If required, request a suitable load carrier from ZF.

6.2 Storage

6.2.1 Short-term storage

NOTICE

Damage to ZF product due to inappropriate storage possible.

- ⇒ Store the ZF product in dry, closed rooms and protect from detrimental influences such as dirt, moisture, temperature and damage.
- ⇒ Failure to comply will void the warranty.

Storage conditions:

- The maximum storage time is 6 months (effectiveness of standard corrosion protection).
- A storage time of more than 6 months requires additional measures (*refer to section Long-term storage*).
- Metallic bright surfaces have been treated with a preservative.
- The storage temperature must be between -40°C and +80°C.
- Store the ZF product in dry, closed rooms with as few temperature fluctuations and low relative humidity as possible.
- Electric components must be protected additionally, e.g., electronic control units, wiring, dashboard.
- Protect the ZF product against dirt, moisture and damage by means of suitable covers and load carriers.
- Store the ZF product in such a way that damage is prevented.

6.2.2 Long-term storage

Storage time longer than 6 months.

NOTICE

Damage to ZF product due to inappropriate storage possible.

- ⇒ Store the ZF product in dry, closed rooms and protect from detrimental influences such as dirt, moisture, temperature and damage.
- ⇒ Failure to comply will void the warranty.



Observe environmental safety instructions (*refer to section General safety instructions*).

Long-term storage of installed axles

- Measures after a storage time of 3 months:
 - Drive vehicle for at least 10 minutes every 3 months.
- Measures after a storage time of 2 years:
 - For wheel bearings with individual bearings which are lubricated with grease, change grease every 2 years and replace shaft sealing ring of hub (*refer to Operating Instructions*).

- Measures after a storage time of 4 years:
 - For compact bearings in the wheel heads which are lubricated with grease, change grease every 4 years and replace shaft sealing ring of hub (*refer to Operating Instructions*).

Long-term storage of uninstalled axles

- Storage conditions:
 - The storage temperature must be between -40°C and +80°C.
 - Protect the ZF product against dirt, moisture and damage by means of suitable covers and load carriers.
 - Store the ZF product in such a way that damage is prevented.
 - Store the ZF product in dry, closed rooms with as few temperature fluctuations and low relative humidity as possible.
 - Depending on the humidity of the storage location, packaging with desiccant, VCI method, may be necessary.²⁾ The packaging should, amongst other things, protect against dust, dirt, salt water, rain, snow, excessive humidity and condensate. The application and calculation of the required desiccant units are described in DIN 55474.
ZF recommendation: VCI film CLIMACOR-V by company Flöter, D-71735 Eberdingen, Germany.
Press out air from packaging before closing the packaging.
 - The packaging, the used desiccants and the corrosion protection must be checked at regular intervals and replaced, if necessary.
 - Electric components must be protected additionally, e.g., electronic control units, wiring, dashboard.
- Measures before storage:
 - Remove brake pad from brakes and apply anticorrosion oil on brake disks, e.g., 0671.196.008 [Anticorrosion oil].
 - Apply anticorrosion oil on all metallic bright surfaces, e.g., 0671.196.008 [Anticorrosion oil].
 - Apply anticorrosion oil in open tapped holes, e.g., 0671.196.008 [Anticorrosion oil]. Screw in screw plugs into tapped holes.
 - If no brake chambers are installed, tightly close the interfaces at the brake.
 - Remove all breathers and screw in screw plugs into tapped holes.
 - Fill axle completely (including all cavities) with oil (*refer to section Oil grade*).
- Measures after a storage time of 3 months:
 - Rotate both wheel heads for at least 5 minutes every 3 months.
 - Driven axles A xxx and AV xxx: Rotate input flange for at least 5 minutes every 3 months.
- Measures after a storage time of 2 years:
 - For wheel bearings with individual bearings which are lubricated with grease, change grease every 2 years and replace shaft sealing ring of hub (*refer to Operating Instructions*).
- Measures after a storage time of 4 years:
 - For compact bearings in the wheel heads which are lubricated with grease, change grease every 4 years and replace shaft sealing ring of hub (*refer to Operating Instructions*).
- Measures before initial operation:
 - Check axle for damage.
 - Check axle for full functioning and smooth running.
 - Remove anticorrosion oil from brake disks and remove rust, if required. Brake disks must be clean, dry, free from grease and oil.
 - Install brake pads.

²⁾ VCI stands for "Volatile Corrosion Inhibitors" which are incorporated into various packaging materials (e.g. polyethylene films, foam materials or papers).

Transport and Storage

- Check brake for full functioning, e.g., smooth running, brake caliper displacement force, function of adjuster.
- Remove anticorrosion oil from all function surfaces, e.g., contact point of wheel to axle, wheel stud, tapered bores, screw-on surfaces for longitudinal rod and V-rod. Function surfaces must be clean, dry, free from grease and oil.
- Remove screw plugs from tapped holes for breathers. Install all breathers.
- Remove screw plugs from tapped holes screwed-in for storage and remove rust, if required.
- Change grease, if required (*refer to Operating Instructions*).
- Drain oil, fill new oil and check oil level (*refer to Operating Instructions*).
- Lubricate all greasing points (*refer to Operating Instructions*).

6.3 Corrosion protection and preservation

Surfaces free of paint are protected by anticorrosion oil or grease.

7 Installation conditions

 The vehicle manufacturer is responsible for the correct installation of the ZF product and the add-on components.

7.1 Arrangement in the vehicle

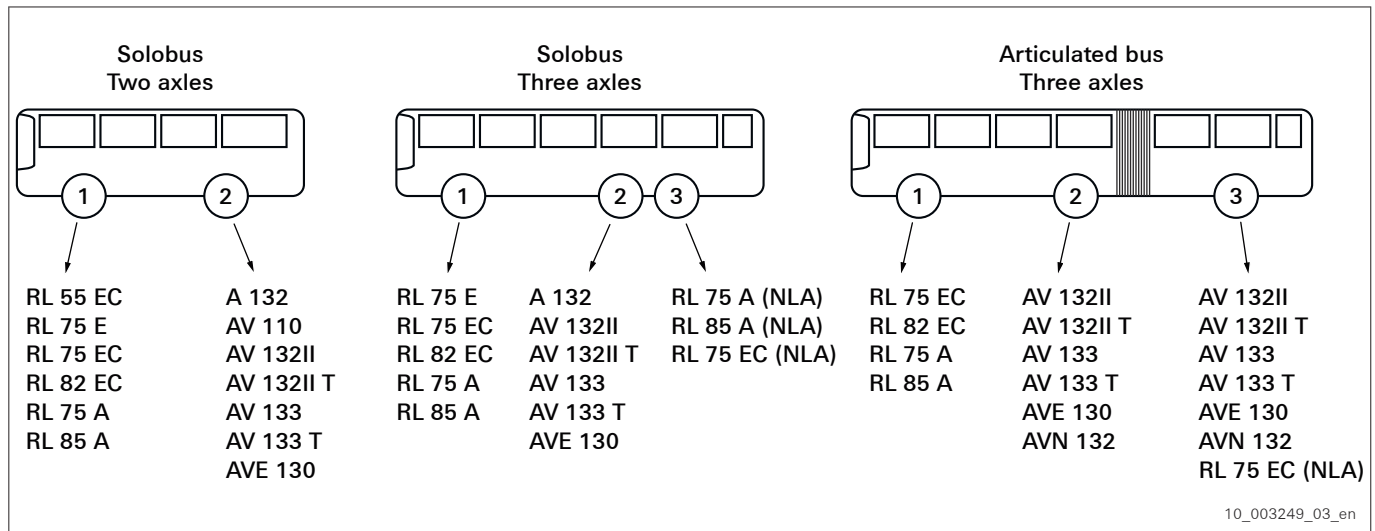

Fig. 19 Arrangement in the vehicle

7.2 Axle suspension

The exact axle guidance is ensured

- by longitudinal rods and V-rods in case of
 - steerable axles with axle beams: RL 75 A, RL 75 A (NLA), RL 85 A, RL 85 A (NLA).
 - non-steerable rear axle systems: A 132, AV 110, AV 132II, AV 132II T, AV 133, AV 133 T, AVE 130, AVN 132.
- by control arms in case of
 - steerable axles with independent suspension: RL 55 EC, RL 75 E, RL 75 EC, RL 75 EC (NLA), RL 82 EC.

In case of deviating, customer-specific axle suspension, consult ZF.

7.2.1 Longitudinal rods and V-rods

ZF axle systems are available with optional longitudinal rods and V-rods.

Longitudinal rods and V-rods serve to guide the axle in longitudinal and transverse direction. Longitudinal rods and V-rods transmit all forces applied to the axle to the chassis, e.g., propulsion forces, brake forces and cornering forces.

Installation conditions

Design the longitudinal rod and V-rod joints in a way that

- the axle can move with the maximum wheel travel.
- the permissible deformation of longitudinal rods and V-rods is complied with also when maximum forces are applied. Impermissible deformation of longitudinal rods and V-rods might result in undesired self-steering of the axle.
- the structure-borne noise transmission is reduced.

The connection to the vehicle frame shall be as stiff as possible so that structure-borne noise transmission is reduced.

If the longitudinal rods and V-rods are not installed by ZF, the vehicle manufacturer shall comply with the specifications of *section Screw-connecting the longitudinal rods and V-rods to the axle*. Complying with the specifications avoids damage to the threads, consoles and ensures a safe screw connection.

7.2.1.1 Installing longitudinal rods and V-rods at axle

The work steps are identical for longitudinal rods and V-rods (in the following just called rods).

- Screw size and thread pitch: *refer to Installation Drawing*.
- Use screws of strength class 10.9.
- Use screws according to ISO 8765.
- Screw-in depth: *refer to Installation Drawing*.
The vehicle manufacturer is responsible for defining the minimum screw-in depth.
- Tighten screws with calibrated torque wrench. Calibration precision $\pm 5\%$.
- Tighten all screws to the specified tightening torque.

NOTICE

Damage to thread when tightening screw possible.

⇒ While tightening the screws, align rod in horizontal position.

1. Align rod (1) at axle in horizontal position.
2. Manually screw in two screws (2) at least 10 mm into the axle.

3. NOTICE

Using non-approved tools might lead to damage.

⇒ Use specified tool.

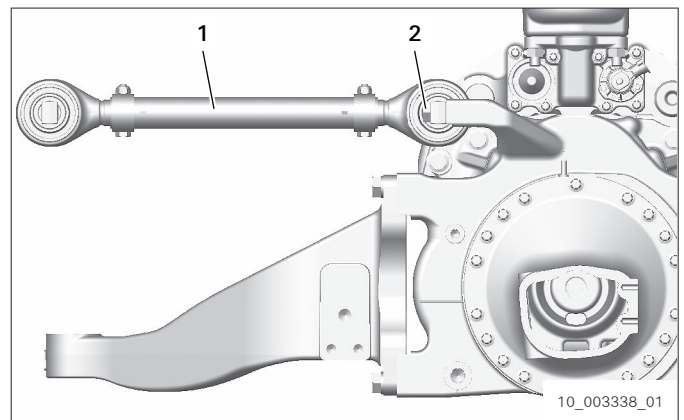

Fig. 20

Manually screw-in two screws (2) or use power screwdriver until firmly home, do not tighten.

Using a pneumatic screwdriver or an impact wrench might damage the thread.

4. Tighten two screws (2) with a calibrated torque wrench.
Tightening torque: *refer to Installation Drawing.*

7.2.1.2 Installing and adjusting longitudinal rod and V-rod at chassis

The axle is positioned and aligned in the chassis by longitudinal rods and V-rods (in the following just called rods). Adjustable or non-adjustable rods can be installed.

Set the axle geometry according to the specifications of the vehicle manufacturer or ZF.

WARNING

**Risk of accident due to rod fracture.
Death or serious injury possible.**

- ⇒ Sufficiently dimension screw-on surface on chassis.
- ⇒ Screw-on surface on chassis must be even and cleaned.

Non-adjustable rods

The axle geometry is set by fitting spacer washers at the screw connection to the chassis. Use spacer washers of sufficient strength.

ZF recommends to use closed spacer washers. Open spacer washers (e.g. U-shaped washers) might get loose and fall off.



The vehicle manufacturer is responsible for dimensioning the screw connection and dimensioning the spacer washers.

Adjustable rods

The axle geometry is set by adjusting the rods.

Adjustable rods are delivered in an assembled state. The vehicle manufacturer sets the rods to the correct length.

WARNING

**Risk of accident due to rod fracture.
Death or serious injury possible.**

- ⇒ Comply with the rod's maximally permissible adjustment range.

Installation conditions

- To adjust the rod, unfasten the two clamps (2) and turn the joint heads (1) into the required direction.
 - Comply with the rod's permissible adjustment range.
Permissible adjustment range, refer to Installation Drawing.
If the adjustment range is exceeded, the rod might brake.
 - Only adjust the rod in a symmetrical manner.
Permissible length difference between X1 and X2: maximally 4 mm.
- After adjustment, tighten screws and nuts (3) at clamps (2).
Tightening torque 70 Nm + 10 Nm

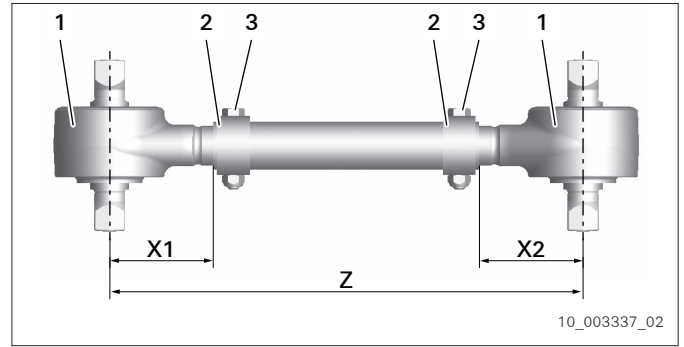



Fig. 21 Adjustable rod

7.2.2 Shock absorber

All ZF axle systems are available with optional shock absorbers and air springs. Shock absorbers and air springs are fine-tuned with each other. If the axle is correctly installed and the design position is correctly set, the wheel travel specified in the installation drawing is guaranteed.

 The shock absorber manufacturer's specifications are binding for the installation and operation of the shock absorbers.

If the shock absorbers are delivered by ZF, you will get the shock absorber manufacturer's specifications from your contact on demand.

7.2.2.1 Shock absorbers by ZF

To achieve the best possible driving properties and the best possible suspension comfort, the shock absorbers must be adjusted to the vehicle-specific characteristics. You will get the technical data and characteristics of ZF shock absorbers from your contact on demand.

Comply with the shock absorbers' installation position according to the installation drawing, e.g., shock absorber position, mounting points at the vehicle, mounting points at the axle.

 Deviating installation of the shock absorbers must be coordinated with ZF.

ZF's shock absorbers are delivered separately as individual parts.

ZF's shock absorbers feature a hydraulic rebound stop. The hydraulic rebound stop limits the maximum wheel rebound of the axle. Additional elements to limit the wheel rebound are not required. The vehicle manufacturer must ensure that the maximum force applied at the rebound stop of a shock absorber does not exceed 30 kN (*refer to section Wheel travel limitation*).

Installation Conditions

- Shock absorber stroke
 - The shock absorber stroke should be as large as or even larger than the wheel travel.
 - If the relation of shock absorber stroke and wheel travel is 1:1, then
 - the shock absorber force is directly effective.
 - the thermal and mechanical load on the shock absorber is the lowest.
- Shock absorber length
 - For thermal and functional reasons, install a preferably long shock absorber.
- Shock absorber installation angle
 - Install the shock absorber as vertically as possible. The larger the installation angle deviation from the vertical position, the larger the required damping forces to achieve the same shock absorbing effect.
 - The maximally permissible installation angle to the vertical position is 45° . The permissible value shall not be exceeded by angular movements, e.g., by spring compression. If the maximally permissible value is exceeded, the shock absorbers will prematurely wear.
- Shock absorber mounting points
 - To avoid a distorted installation and premature shock absorber wear,
 - the upper and lower joints must be in line in the vehicle's design position.
 - the joints must be installed in the axle's design position with a deflection angle of $\delta/2 = 0^\circ$.
- Shock absorber ambient temperature
 - Ensure cooling of the shock absorber by wind blast.
 - Protect the shock absorber from heat impact from the exhaust system and other heat sources. Fit suitable shields, if required.

7.2.2.2 Shock absorber joints

The shock absorber joints constitute the elastic and noise-insulating connection between axle and chassis. The shock absorber joints transmit tension forces, compressive forces and absorb angular movements.

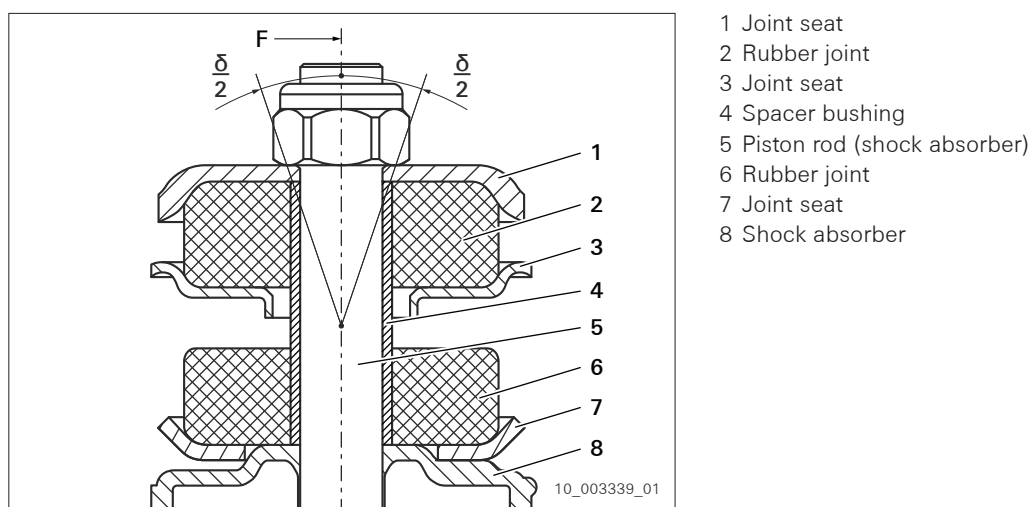

Fig. 22 Shock absorber joint

Installation conditions

The **maximum deflection angle** $\delta/2 = \max. 5^\circ$ must be adhered to under all operating conditions.

Observe when installing shock absorbers and shock absorber joints:

- Number and design of joint seats.
- Installation position of joint seats.
- Number and design of rubber joints.
- Installation position of rubber joints.
- Correct installation of spacer bushing.

7.2.3 Air spring

All ZF axle systems are available with optional shock absorbers and air springs. Shock absorbers and air springs are fine-tuned with each other. The air springs are adapted to the vehicle-specific axle load and vehicle-specific axle system.

 The air spring manufacturer's specifications are binding for the installation and operation of the air springs.

If the air springs are delivered by ZF, you will get the air spring manufacturer's specifications from your contact on demand.

7.2.3.1 Air springs by ZF

You will get the technical data of ZF air springs from your contact on demand.

Comply with the air springs' installation position according to the installation drawing, e.g., mounting points at the vehicle, mounting points at the axle.

 Deviating installation of the air spring shall be agreed with ZF.

Depending on the axle system, the air springs delivered by ZF are delivered in an assembled state or separately as individual parts.

To limit the spring compression, air springs delivered by ZF feature an integrated, progressive rubber bump stop (*refer to section Wheel travel limitation*).

The air spring bellows shall not be overstretched at rebound (*refer to section Wheel travel limitation*).

 The vehicle manufacturer is responsible for limiting the wheel rebound, e.g., by correctly dimensioned and installed shock absorbers.

Installation Conditions

- Protect air spring from heat impact from exhaust system and other heat sources. Fit suitable shields, if required.
- Protect air spring against stone impact and chafe marks. Fit suitable stone guard plate, if required.
- Comply with specified tightening torques for fixing screws (*refer to Installation Drawing*).

- Install top plate of air spring according to specifications in the installation drawing and ensure that there is no unacceptable offset to the air spring piston during compression.
- The air springs shall not have contact to the following media:
 - Solvents
 - Paints, varnishes
 - Underbody protection and preservatives
 - Fuels and oils
 - Brake fluid

Inflation of air spring

- Only inflate air spring when installed.

7.2.4 Wheel travel limitation

 WARNING
<p>Risk of accident due to unacceptable wheel travel. Death or serious injury possible.</p> <p>⇒ Comply with specified maximum compression and rebound.</p>

 The vehicle manufacturer is responsible for limiting the compression and rebound.

Limitation of compression

The spring compression is limited by a progressive rubber bump stop integrated in the air spring. If the air spring is non-pressurized, the maximum wheel load is transmitted by the rubber bump stop.

Limitation of rebound

ZF's shock absorbers feature a hydraulic rebound stop. The hydraulic rebound stop limits the maximum wheel rebound of the axle. Additional elements to limit the wheel rebound are not required. The vehicle manufacturer is responsible for the maximum force applied at the rebound stop of the shock absorber not exceeding 30 kN.

Example: Wheel travel limitation of RL 75 EC

- Design position: air spring (2) and shock absorber (3) in construction position according to installation drawing.
- Compressed: air spring (2) and rubber bump stop (1) are completely compressed. The compression is limited by the rubber bump stop in the air spring.
- Rebound: air spring (2) and rubber bump stop (1) are completely stretched. The rebound is limited by the rebound stop in the shock absorber.

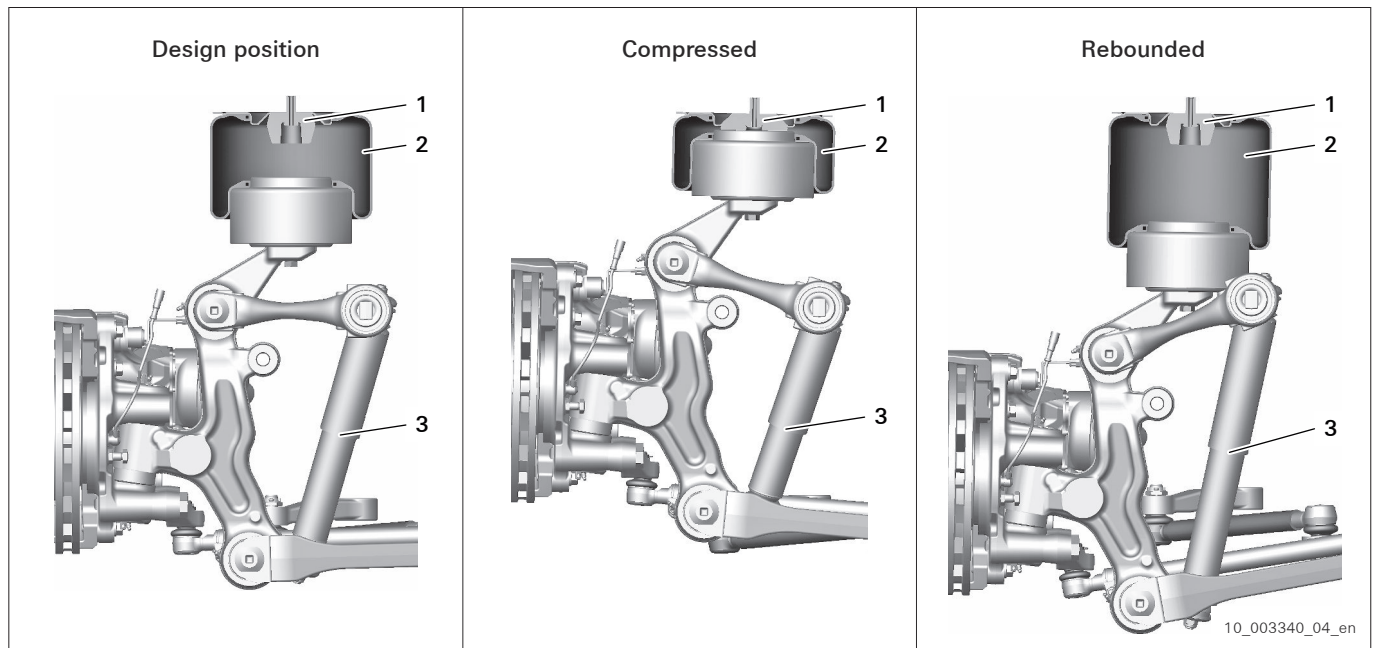



Fig. 23 Example RL 75 EC

7.2.5 Stabilizer bar

All ZF axle systems might be equipped with a stabilizer bar. Connecting points for the stabilizer bar are provided at the axles (*refer to Installation Drawing*).

 The vehicle manufacturer is responsible for dimensioning and installing the stabilizer bar.

Installation conditions

- The stabilizer bar installed must enable the complete rebound and compression of the axle.
- Use the provided connecting points at the axle (*refer to Installation Drawing*).
- Before installation, remove grease from tapered bores at the axle and the stabilizer bar's conical studs.
- Do not distort stabilizer bar during installation.
- Comply with the specified tightening torques for the corresponding joint sizes (*refer to fig. 24, page 33*).

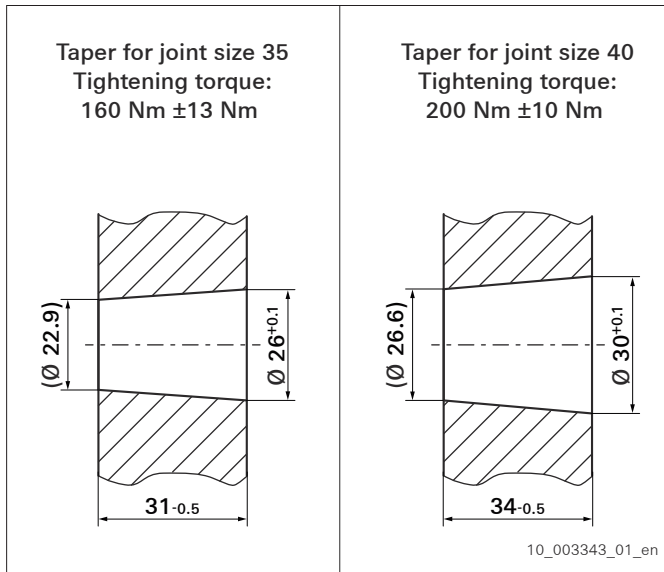



Fig. 24 Stabilizer bar connection

7.3 Installation conditions for axle type RL

 The vehicle manufacturer is responsible for installing axle halves with the same serial number. Before installing the axle, check the serial number of the right axle half and the serial number of the left axle half on the type plates.

The axles are delivered with the customer-specific axle suspension parts (e.g. transverse rods, shock absorbers, air springs).

Comply with the positioning of the axle and all suspension parts according to the Installation Drawing. The steering geometry design and the set axle geometry influence

- the tire service life.
- the vehicle's driving behavior (e.g. straight-running stability).
- the vehicle's steering behavior (e.g. steering centering).

Before starting operation, the vehicle manufacturer must correctly set the level of

- the air springs in the design position.
- the left and right air springs (evenly).

Deviating settings must be agreed with ZF.

7.3.1 Steering geometry

NOTICE

Damage by steering gears with too high sector shaft torques.

⇒ Only use steering gears complying with ZF's specifications.

The steering linkage components available from ZF (track lever, steering lever, relay lever, tie rods) are dimensioned for steering gears with a maximum sector shaft torque of 8,000 Nm.

Use of the following steering gears or steering systems must be agreed with ZF.

- Steering gears with sector shaft torques of more than 8,000 Nm.
- Dual-circuit steering systems.
- Steering gears with additional support by an electric motor.

 Deviating or incorrect steering geometry results in higher tire wear. ZF recommendation: Comply with the steering linkage position according to the specifications in the installation drawing.

The steering linkage position

- was tested in driving tests.
- is designed for wheelbases of about 5,500 mm to 6,500 mm.

For deviating wheelbases, the steering geometry must be checked by calculation. If required, the steering geometry is adapted to the deviating wheelbase.

- ensures the correct steering angle ratio of inside and outside wheel (Ackermann geometry).
- and the pitman arm length guarantee the largest possible, symmetric utilization of the steering gear (angle of pitman arm at least $\pm 45^\circ$).

The dimensions and tolerances specified guarantee that the calculated steering angle is achieved (*refer to fig. 25, page 35*). Deviating dimensions and tolerances change the steering angle.

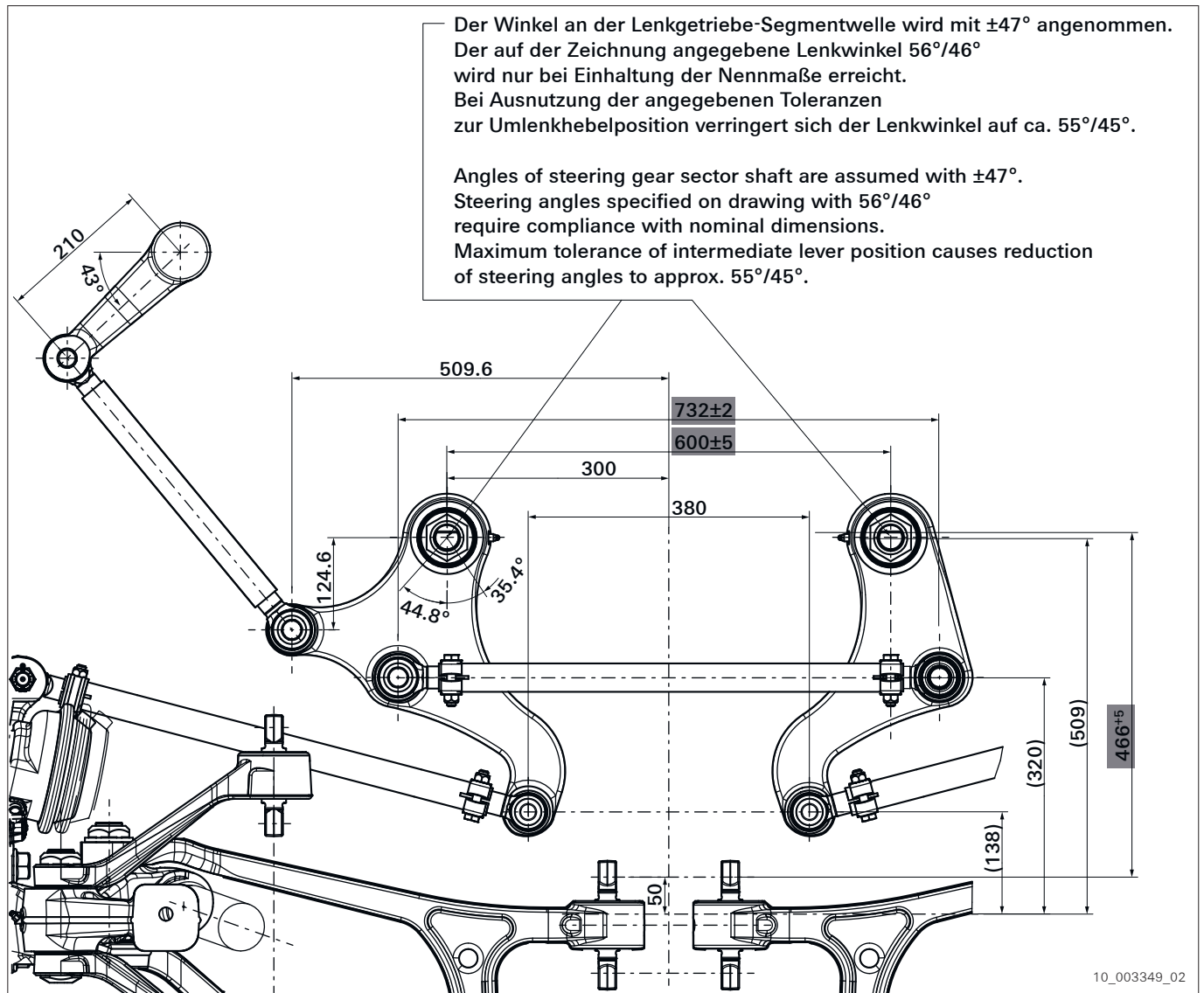

Fig. 25 Example RL 75 EC Excerpt from installation drawing

7.3.2 Track adjustment



The vehicle manufacturer is responsible for track adjustment.

Installation conditions

ZF recommendation:

- Position the tie rods and the steering drag link according to specifications of the installation drawing.
- Also coordinate the toe-in target value with the tire manufacturer.

The track adjustment is performed by the vehicle manufacturer before taking the vehicle into operation. The track is adjusted by adjusting the tie rods and the steering drag link. The position of the tie rods and the steering drag link has been analyzed theoretically and was tested in driving tests.

An incorrect position of the tie rods and/or the steering drag link might

- result in undesired self-steering during compression, rebound or braking.
- result in excessive bump toe-in during compression, rebound and braking in case of the axles RL 55 EC, RL 75 E, EL 75 EC, EL 75 EC (NLA), RL 82 EC and thus might result in excessive tire wear.

Toe-in target value

- Rim 22.5": 0 mm to +2 mm.
- Rim 19.5": 0 mm to +2 mm.

7.3.2.1 Measuring the toe-in

1. Set steering gear to the center position and fix (observe zero mark at steering gear input).
2. Measure dimension A and dimension B at the rim's outside diameter using a laser-optical measuring instrument.
(Example: dimension A = 2,510 mm; dimension B = 2,512 mm)
3. Calculation of toe-in:
Toe-in = dimension B – dimension A
(Example: toe-in = 2,512 mm – 2,510 mm = 2 mm)

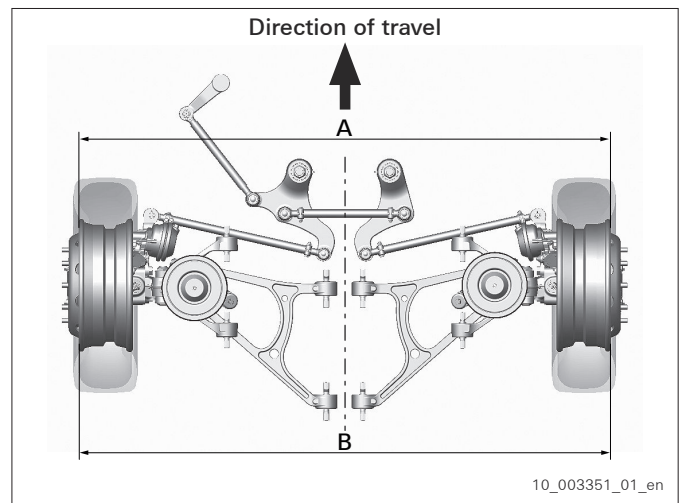

Fig. 26 Example RL 75 EC

7.3.2.2 Track adjustment of axles RL 55 EC, RL 75 EC, RL 82 EC and tag axle RL 75 EC (NLA)

1. Set steering gear to the center position and fix (observe zero mark at steering gear input).
2. Symmetrically set the position of the two relay levers. Dimension D and dimension E must be identical at the left and right relay lever.
For dimension D and dimension E, refer to installation drawing.
3. Set toe-in symmetrically for every wheel using the corresponding tie rod (right wheel with right tie rod, left wheel with left tie rod). Dimension C must be identical at both rims. If the toe-in is only set at one wheel, the steering is asymmetrical (dimension C at right rim and dimension C at left rim are different).

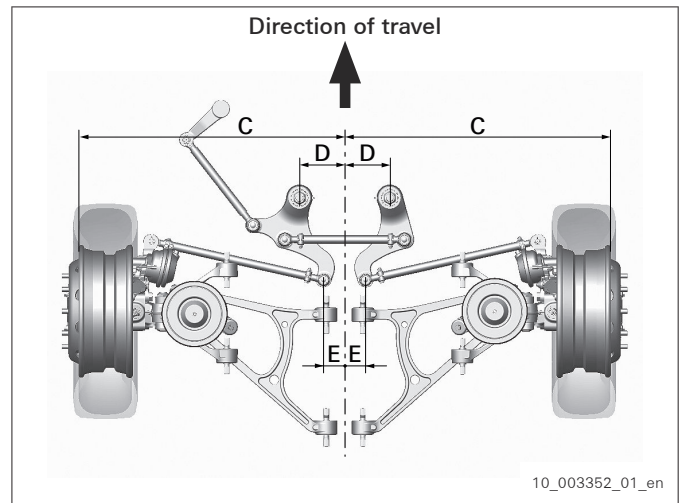

Fig. 27 Example RL 75 EC

4.

WARNING
<p>Risk of accident due to incorrect installation. Death or serious injury possible.</p> <p>⇒ Observe provisions for installation.</p>

Install clamps at tie rods in correct position and tighten (*refer to Installation Drawing*). A deviating position might result in collision of tie rod and axle in operation.

5. Measure toe-in (*refer to section Measuring the toe-in*).

7.3.2.3 Track adjustment of axle RL 75 E

1. Set steering gear to the center position and fix (observe zero mark at steering gear input).
2. Axially align position of pitman arm (point F). For position of point F, refer to installation drawing.
3. Symmetrically set position of pitman arm. Dimension G must be identical on the right and left hand side. For dimension G, refer to Installation Drawing.
4. Set toe-in symmetrically for every wheel using the corresponding tie rod (right wheel with right tie rod, left wheel with left tie rod). Dimension C must be identical at both rims. If the toe-in is only set at one wheel, the steering is asymmetrical (dimension C at right rim and dimension C at left rim are different).
5. Measure toe-in (*refer to section Measuring the toe-in*).

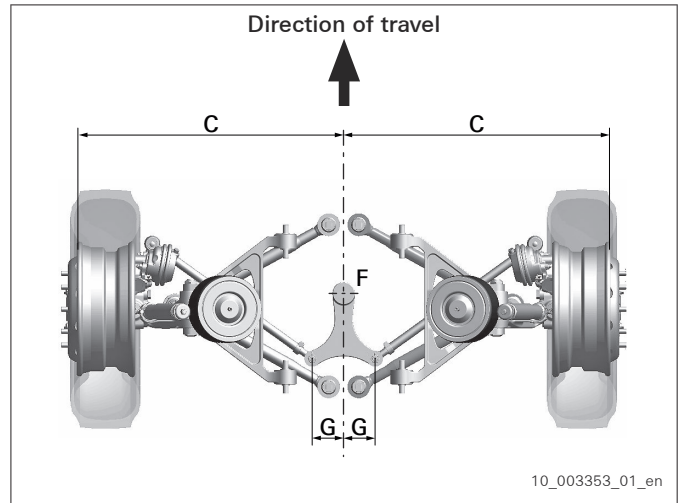

Fig. 28 RL 75 E

7.3.2.4 Track adjustment of axles RL 75 A, RL 85 A

1. Set steering gear to the center position and fix (observe zero mark at steering gear input).
2. Set straight-ahead position of wheel at pushrod side using the steering drag link.
3. Set toe-in using tie rod.
4. Measure toe-in (*refer to section Measuring the toe-in*).

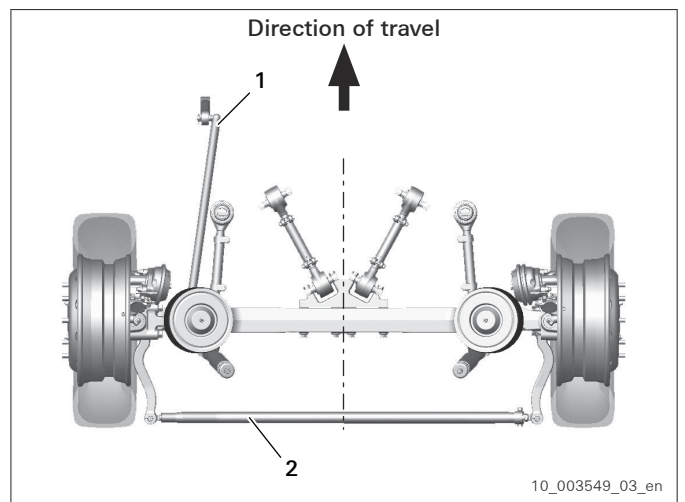

Fig. 29 Example RL 75 A

- 1 Steering drag link
- 2 Tie rod

7.3.2.5 Track adjustment of tag axles RL 75 A (NLA), RL 85 A (NLA)

1. Position the tag axle geometrically to the driven rear axle in the straight-ahead position (locked state).
Maximum deviation of 2 mm/m of the track of the driven rear axle. A larger deviation results in an increased tire wear.
2. Set toe-in.
3. Set lock position for straight-ahead position (toe-in must have been set):
 - In case of RL 75 A (NLA) passive and RL 85 A (NLA) passive by means of pneumatic locking cylinder.
 - In case of RL 75 A (NLA) active and RL 85 A (NLA) active by means of hydraulic steering cylinder.

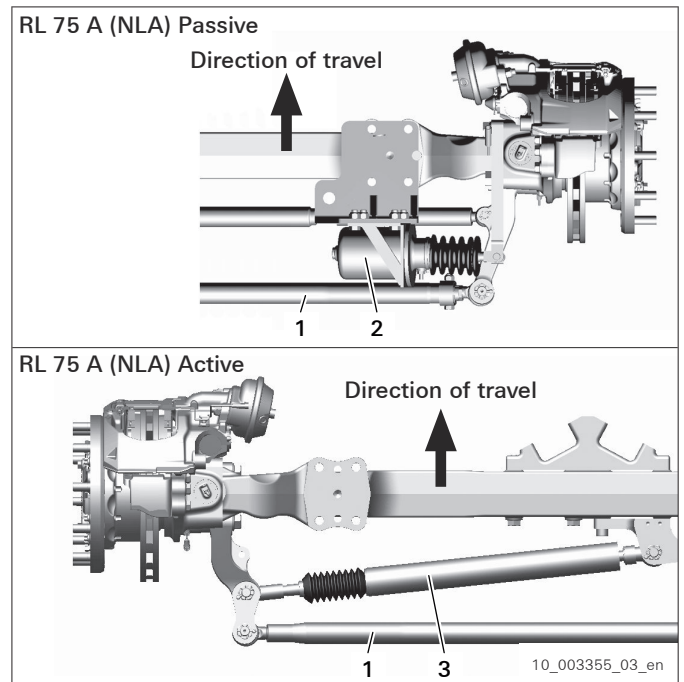

Fig. 30 Example RL 75 A (NLA)

- 1 Tie rod
- 2 Pneumatic locking cylinder
- 3 Hydraulic steering cylinder

7.3.3 Steering linkage and steering spindle

Design the whole steering linkage arrangement in a stiff way and with low clearance to ensure the direct transmission of the steering commands.

Design the transmission parts between steering wheel and steering gear with low friction. Friction has a negative effect on the straight-ahead driving behavior and the steering feedback.

7.3.4 Steering stop and steering gear setting

The mechanical steering stops have been set by ZF (for dimensions, refer to current Installation Drawing). Subsequent change of steering stops is only possible after consultation of ZF.

The vehicle manufacturer shall ensure that not the complete hydraulic steering assistance presses against the axle's steering stop. Before the steering stop is hit, the steering limitation valve of the steering gear must reduce the hydraulic steering assistance.

To use snow chains, the vehicle manufacturer shall provide sufficient clearance to all axle parts. If required, install a steering angle reduction.

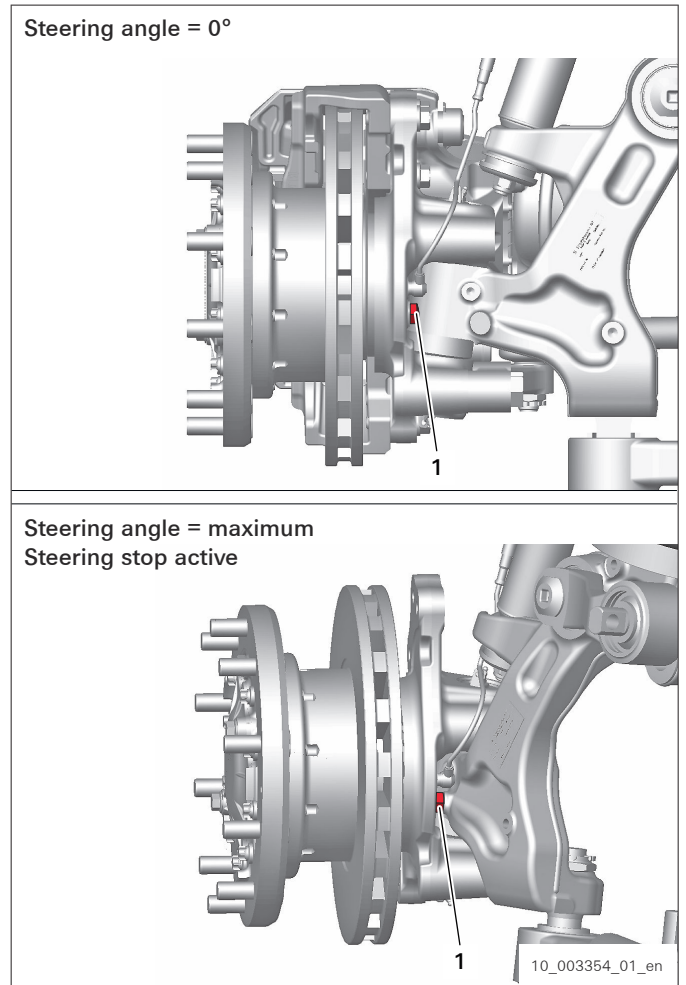



Fig. 31

1 Steering stop

7.3.5 Setting the axle geometry

 The vehicle manufacturer is responsible for setting the axle geometry. ZF recommendation: Before taking into operation, check the axle geometry using laser-optical measuring instruments.

The axle geometry is set by the vehicle manufacturer before the vehicle is taken into operation. The settings recommended in the Installation Drawing shall be adhered to. Deviating settings must be agreed with ZF.

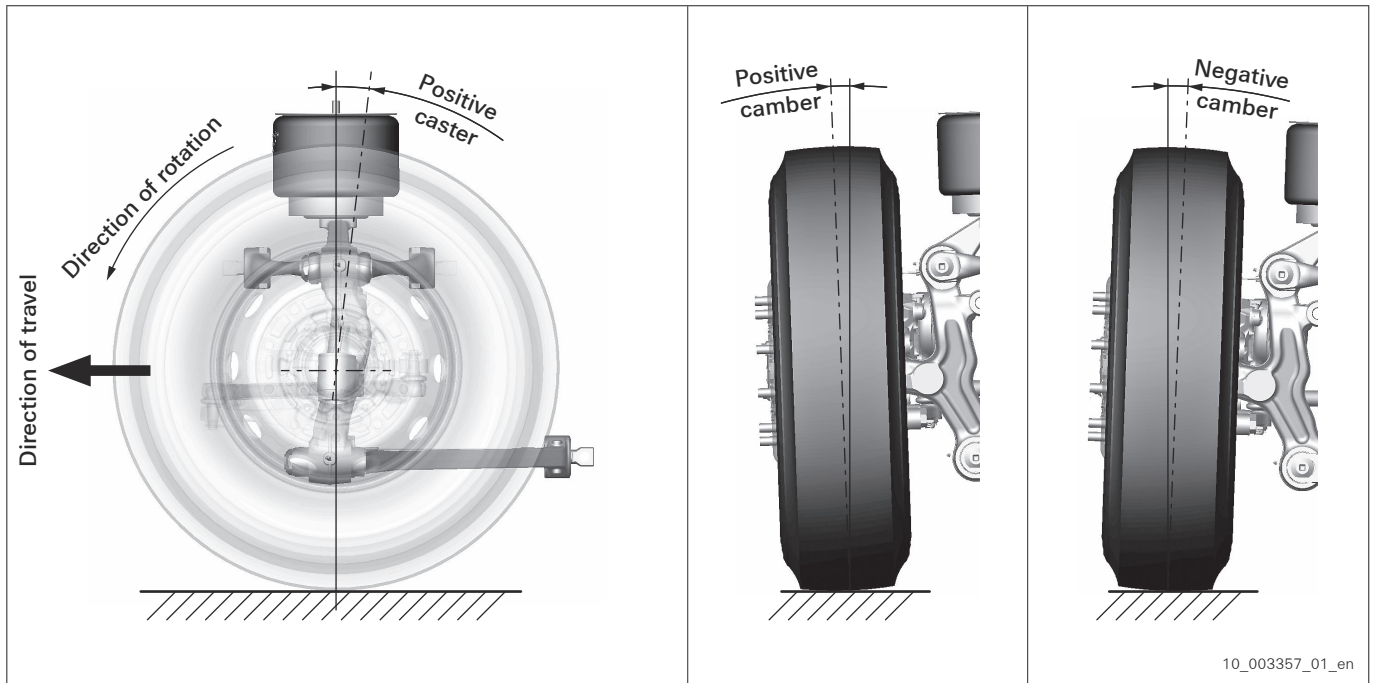

Fig. 32 Axle geometry: caster and camber

Caster (caster angle): angle between steering rotation axis angle and the perpendicular to the road surface.
 Camber: angle between the wheel's center plane and the perpendicular to the road surface.

Setting the axle geometry for axles RL 75 A, RL 75 A (NLA), RL 85 A, RL 85 A (NLA):

- The caster is set by setting the longitudinal rods and V-rods (*refer to section Fitting and setting longitudinal rods and V-rods at chassis*). Target value for caster: *refer to Installation Drawing*.
- The camber is pre-set by design. Changing the setting is not possible.

Setting the axle geometry for axles RL 55 EC, RL 75 E, RL 75 EC, RL 75 EC (NLA), RL 82 EC:

- The caster is pre-set by design. Changing the setting is not possible.
- The camber is set by adjustment shims. Fit four adjustment shims of the same thickness at each vehicle side at the marked screw connections to the chassis. Target value for camber: *refer to Installation Drawing*.
 - Fit at (1) for positive camber change.
 - Fit at (2) for negative camber change.

According to the thickness s of the adjustment shim, the following camber changes can be set:

- $s = 1 \text{ mm}$: 0.14° camber change
- $s = 3 \text{ mm}$: 0.40° camber change
- $s = 5 \text{ mm}$: 0.70° camber change

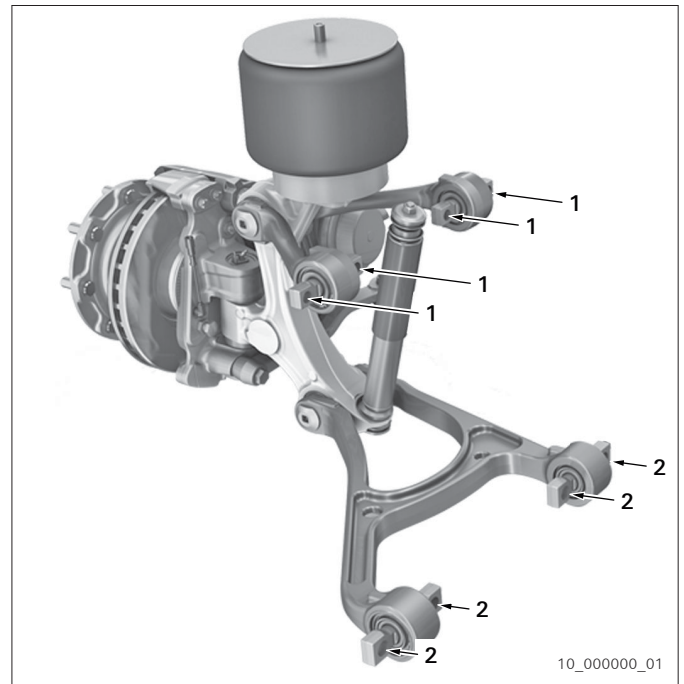



Fig. 33

7.4 Installation conditions for axle types A, AV, AVN, AVE

The axles are delivered with the customer-specific axle suspension parts (e.g. longitudinal rods, V-rods, shock absorbers, air springs).

 The vehicle manufacturer is responsible for setting the axle geometry. ZF recommendation: Before taking into operation, check the axle geometry using laser-optical measuring instruments.

Comply with the positioning of the axle and all suspension parts according to the Installation Drawing. When installing the axle, observe the specifications for air springs and propshaft. The installation has an impact on

- the axle's noise characteristics.
- the propshaft's service life.
- the suspension's service life.
- the oil supply.

Before starting operation, the vehicle manufacturer must

- correctly set the air spring level in construction position.
- evenly set the level of the left and right air springs.

Deviating settings must be agreed with ZF.

7.4.1 Spring carrier

ZF axle systems are delivered with spring carriers by default. A deviating delivery state shall be agreed with ZF.

- Spring carriers are generally installed: A 132.
- Spring carriers are installed by default: AV 110, AV 132II, AV 132II T, AV 133, AV 133 T, AVE 130, AVN 132.

If the spring carriers are not installed by ZF, the vehicle manufacturer shall comply with the specifications for installing the spring carriers (*refer to section Installing spring carrier at axle*). Complying with the specifications avoids damage to the threads, consoles and ensures a safe screw connection.

7.4.1.1 Installing spring carrier at axle

The following applies for axles AV 110, AV 132II, AV 132II T, AV 133, AV 133 T, AVE 130, AVN 132:

- Screw size and thread pitch: *refer to Installation Drawing*.
- Use screws according to ISO 8676 or DIN 34800.
- Use screws of strength class 10.9 in rerolled or final-rolled quality.
- Use hardened washers with outside diameter of at least 33 mm. Unhardened washers and spring washers are prohibited.
- Screw-in depth: *refer to Installation Drawing*.
The vehicle manufacturer is responsible for defining the minimum screw-in depth.
- Tighten screws with calibrated torque wrench. Calibration precision $\pm 5\%$.

Installation conditions

- Tighten all screws to the specified tightening torque.

1. Screw in two M20x1.5 centering pins (1).

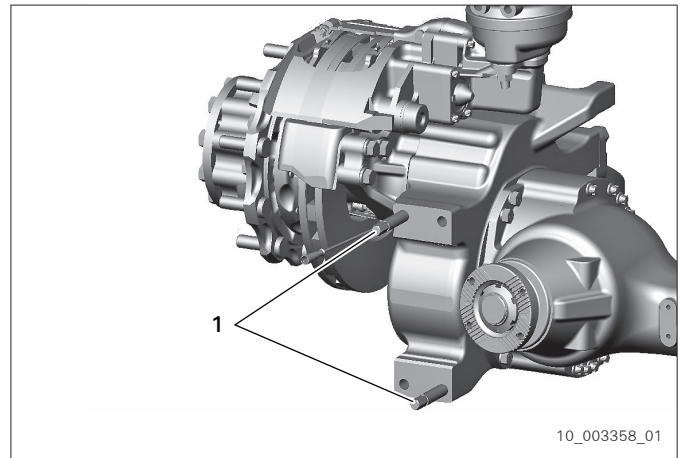

Fig. 34

2. Push on spring carrier (1) and align in horizontal position.
3. Manually screw in two screws (2) with hardened washers (3) at least 10 mm into the axle.

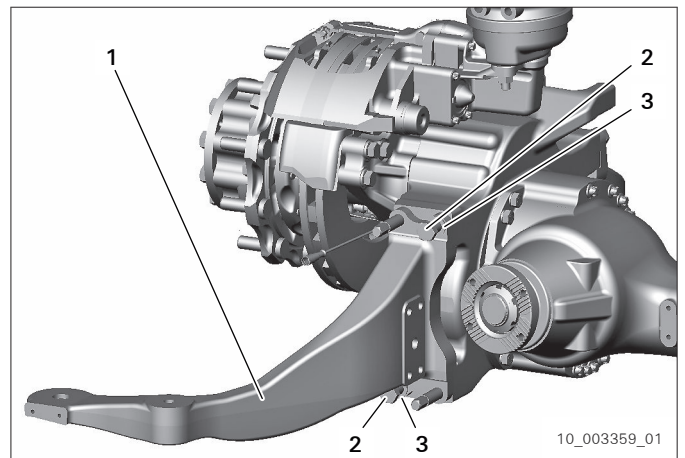

Fig. 35

4.

NOTICE

Using non-approved tools might lead to damage.

⇒ Use specified tool.

Manually screw-in two screws (1) or use power screwdriver until firmly home, do not tighten.

Using a pneumatic screwdriver or an impact wrench might damage the thread.

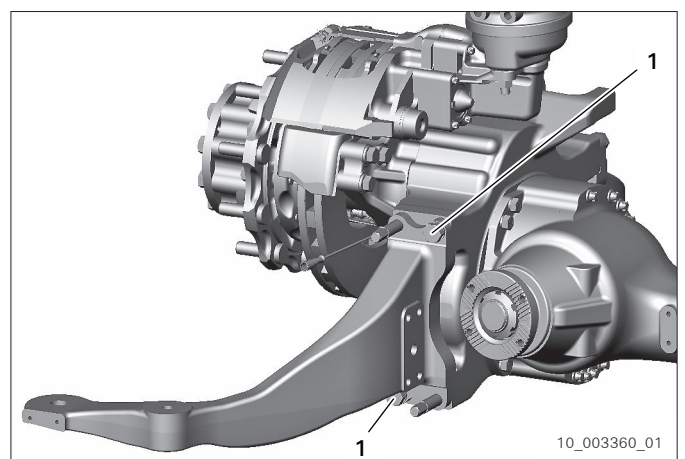

Fig. 36

5. Remove two centering pins.
6. Manually screw in two screws (1) with hardened washers (2) at least 10 mm into the axle.

7. **NOTICE**
Using non-approved tools might lead to damage.
 ⇒ Use specified tool.

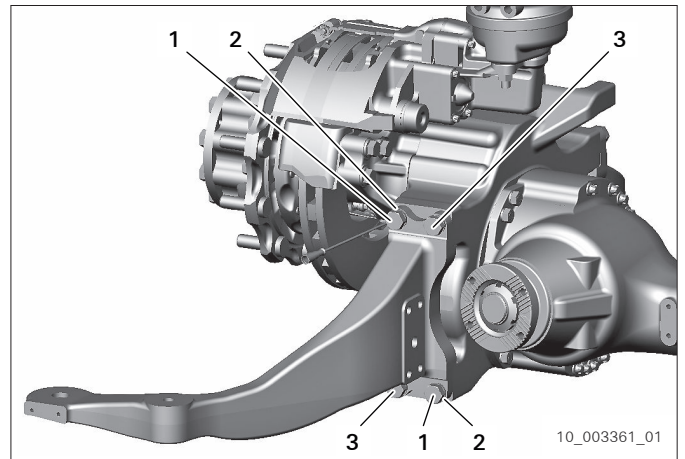

Fig. 37

Manually screw-in two screws (1) or use power screwdriver until firmly home, do not tighten.

Using a pneumatic screwdriver or an impact wrench might damage the thread.

8. Tighten four screws (1, 3) with a calibrated torque wrench.
 Tightening torque: 620 Nm for M20x1.5 - 10.9 screw with friction coefficient $\mu_{total} = 0.12$. Adapt tightening torque in case of deviating friction coefficient.

7.4.2 Positioning axle in chassis

i The vehicle manufacturer is responsible for positioning the axle in the chassis. ZF recommendation: Position longitudinal rods, V-rods, shock absorbers and air springs according to the specifications of the Installation Drawing.

Installation conditions

The axle is positioned by the vehicle manufacturer before the vehicle is taken into operation. The positioning is done by setting the longitudinal rods and V-rods (*refer to section Fitting and setting longitudinal rods and V-rods at chassis*).

The four shock absorbers must have the same length (A) in construction position. Permissible difference between shortest and longest shock absorber: 10 mm.

The air spring's top plate and the supporting surface at the spring carrier must be horizontal.

The four air springs must have the same height (B) in construction position and must be horizontally aligned. Permissible difference between shortest and longest air spring: 10 mm.

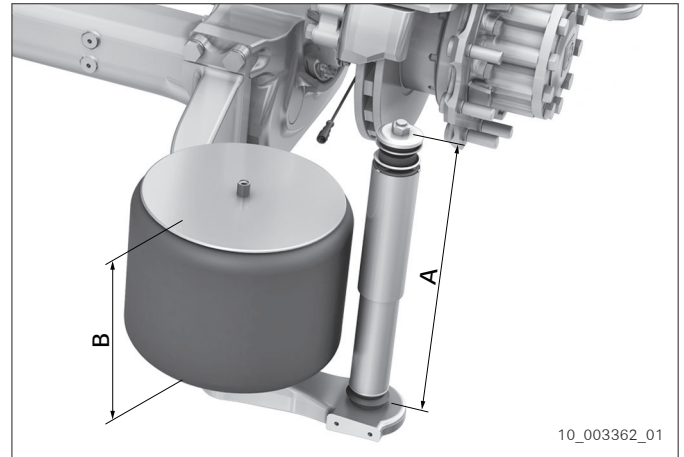

Fig. 38

Target value of thrust angle: maximum deviation of 2 mm/m or $\pm 0.15^\circ$ rectangular to vehicle's longitudinal axis. A larger deviation impairs the straight-running behavior.

7.4.3 Propshaft

A propshaft may be the cause of torsional and bending vibrations in the driveline. Torsional and bending vibrations might result in noises in the driveline.

Noises in the driveline might be caused, e.g., if one of the following points is exceeded or if several points are combined with their limit values:

- Spatial deflection angle β_R too large.
- Tolerance of deflection angel β_{R1} to β_{R2} too large.
- Propshaft speed too high.
- Propshaft too long
- Residual unbalance too large.
- Propshaft installed in W arrangement.



The vehicle manufacturer is responsible for designing the propshaft with regard to perfect vibrations. ZF recommendation: Design the propshaft together with the propshaft manufacturer.

The vehicle manufacturer and the propshaft manufacturer are responsible for ensuring that the overall system works without additional loads on the individual units.

Since a vibration analysis cannot be performed for every application, boundary conditions based on ZF's long-standing experience are stated below. The boundary conditions

- are aligned to the requirements in the vehicle driveline and partly deviate from the provisions of the propshaft manufacturers.
- describe the operating ranges of a driveline in which no noteworthy additional loads due to vibrations have to be expected.

If these values cannot be met, a closer investigation by the vehicle manufacturer and propshaft manufacturer is required.

7.4.3.1 Definition of terms

The extent of a possible vibration excitation by propshafts is largely determined by the deflection angles of the universal joints.

The following definitions apply:

- **Deflection angle β**
The deflection angle β is defined as the angle between the axes of rotation in front of and behind the joint in the plane that is formed by the two axes of rotation (Refer to Figure A).
- **Spatial deflection angles β_R**
To evaluate a propshaft alignment, the spatial deflection angle β_R for each individual joint must be determined first according to the following formula:

$$\beta_R = \arctan \sqrt{\tan^2 \beta_H + \tan^2 \beta_V}$$

β_H = Deflection angle in horizontal view

β_V = Deflection angle in vertical view

- Depending on the shaft routing, we speak of a W arrangement (Refer to Figure B) or Z arrangement (Refer to Figure C).
Avoid W arrangements in general.

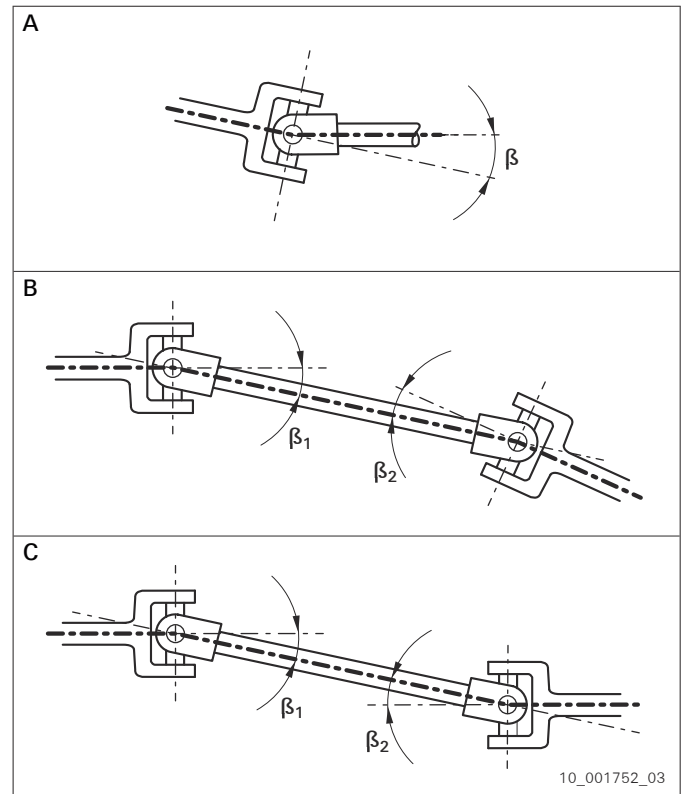

Fig. 39

7.4.3.2 Permissible spatial deflection angle

The limit value for the spatial deflection angle β_R applies to the design position of the vehicle. Fully compressed and fully rebounded, this value might be exceeded.

An axle suspension with longitudinal rods and V-rods results in a parallel axle movement during compression and rebound. Thus, the provision $\beta_{R1} = \beta_{R2}$ remains true to a great extent during compression and rebound.

Propshaft with two joints

Both joints are turned by 90° against each other (refer to fig. 40, page 48).

Output fork of joint 1 and input fork of joint 2 are in one level.

Usually, shafts with length compensation are marked by the manufacturer so that an incorrect connection of the two parts in the sliding piece is avoided.

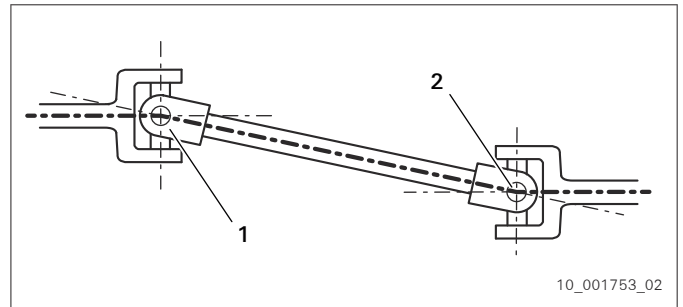

Fig. 40

- 1 Joint 1
- 2 Joint 2

ZF recommendation:

- Limit value for spatial deflection angle $\beta_R \leq 6^\circ$ for any individual joint.
- Parallel arrangement of transmission output flange and axle input flange.
- The spatial deflection angles of joint 1 and joint 2 should be the same. $\beta_{R1} = \beta_{R2}$.
- Tolerances for the deflection angle β_R (β_{R1} , β_{R2}):
 - If $\beta_R \leq 5^\circ$, then $\beta_{R1} - \beta_{R2} \leq 1^\circ$.
 - If $\beta_R > 5^\circ$ and $\leq 6^\circ$, then $\beta_{R1} - \beta_{R2} \leq 0,5^\circ$.
- Install propshaft in **Z arrangement**. Avoid W arrangement.

Every deviation from this recommendation means more vibration excitation by the propshaft. This will result in a loss of comfort, especially in the event of acoustically sensitive vehicles.

Propshaft line with more than two joints

If the permissible propshaft length were exceeded for a propshaft with two joints, a multipiece propshaft line is required. In most cases, the propshaft line will then consist of two propshafts with three joints.

ZF recommendation:

- Limit value for spatial deflection angle $\beta_R \leq 6^\circ$ for any individual joint.
- Parallel arrangement of transmission output flange and axle input flange.
 - Tolerance for deviation of parallelism:
 - If $\beta_R \leq 5^\circ$, then maximally 1° .
 - If $\beta_R > 5^\circ$ and $\leq 6^\circ$, then maximally 0.5° .
- Difference between total of both smaller deflection angles and the larger deflection angle = maximally 2° .
 - Example: $(5^\circ + 3^\circ) - 6^\circ = 2^\circ$ (refer to fig. 42, page 49).
- Difference between two larger deflection angles = maximally 1° .

Example: $6^\circ - 5^\circ = 1^\circ$ (refer to fig. 42, page 49).

- Difference between the two smaller deflection angles = maximally 2° .

Example: $5^\circ - 3^\circ = 2^\circ$ (refer to fig. 42, page 49).

In the event of more than two joints, the two joints with the largest deflection angles respectively must be turned by 90° against each other.

For verification in the vehicle, the illustrated marking is introduced.

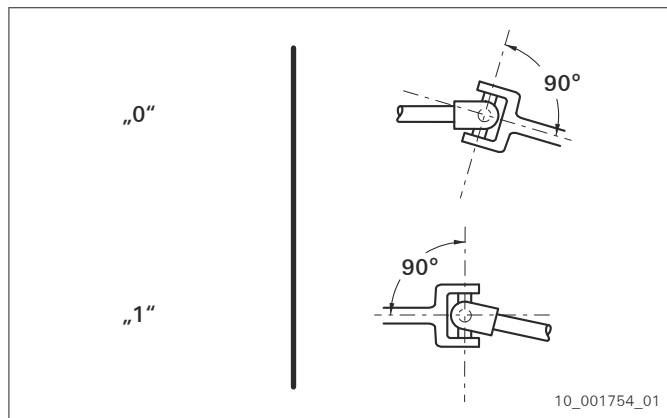

Fig. 41

As shown in examples A and B, the two joints with the largest deflection angles may not have the same marking.

A remaining joint (with odd number of joints) should be arranged like the joint with the smaller angle.

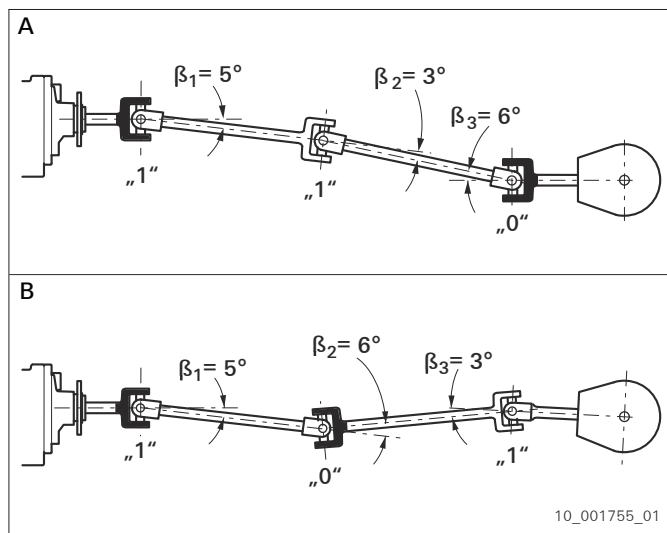

Fig. 42

i If a propshaft is installed in W arrangement, the measures described in this Technical Manual are not sufficient.

An experienced propshaft manufacturer must always be consulted in case of a W arrangement to prevent vibration problems.

7.4.3.3 Permissible propshaft speed depending on spatial deflection angle

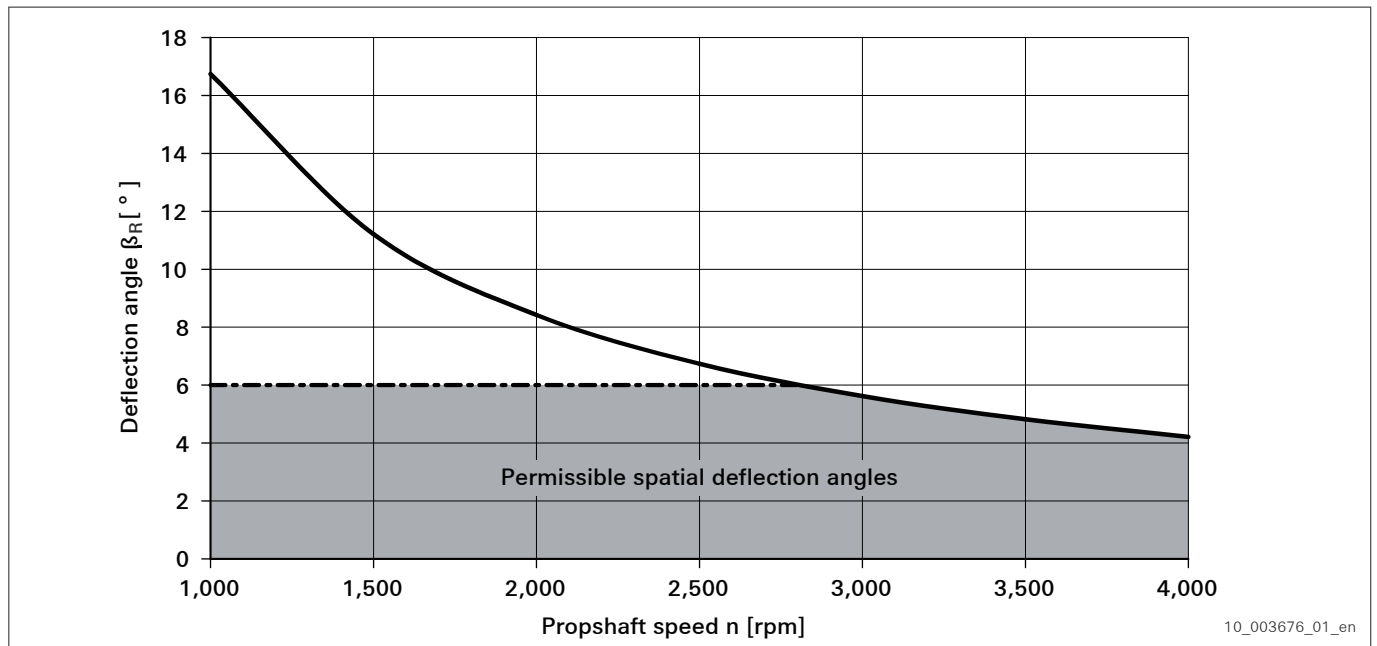

Fig. 43

For deflection angles β_R which, depending on the speed, are larger than the values stated in the figure, there might be the risk of noise emission from the propshaft.

The limit value for deflection angle $\beta_R \cdot$ propshaft speed is 17,000. Thus, a maximum propshaft speed of about 2,800 rpm applies for $\beta_R = 6^\circ$.

7.4.3.4 Permissible propshaft speed depending on length and diameter

To avoid bending vibrations, the propshaft must not be operated with more than 80% of the speed critical for bending. The figure shows the limit speeds depending on propshaft length L as well as tube diameter D (middle part). To a great extent, both of these parameters are decisive for the first natural bending frequency.

The vehicle manufacturer is responsible for design and setup.

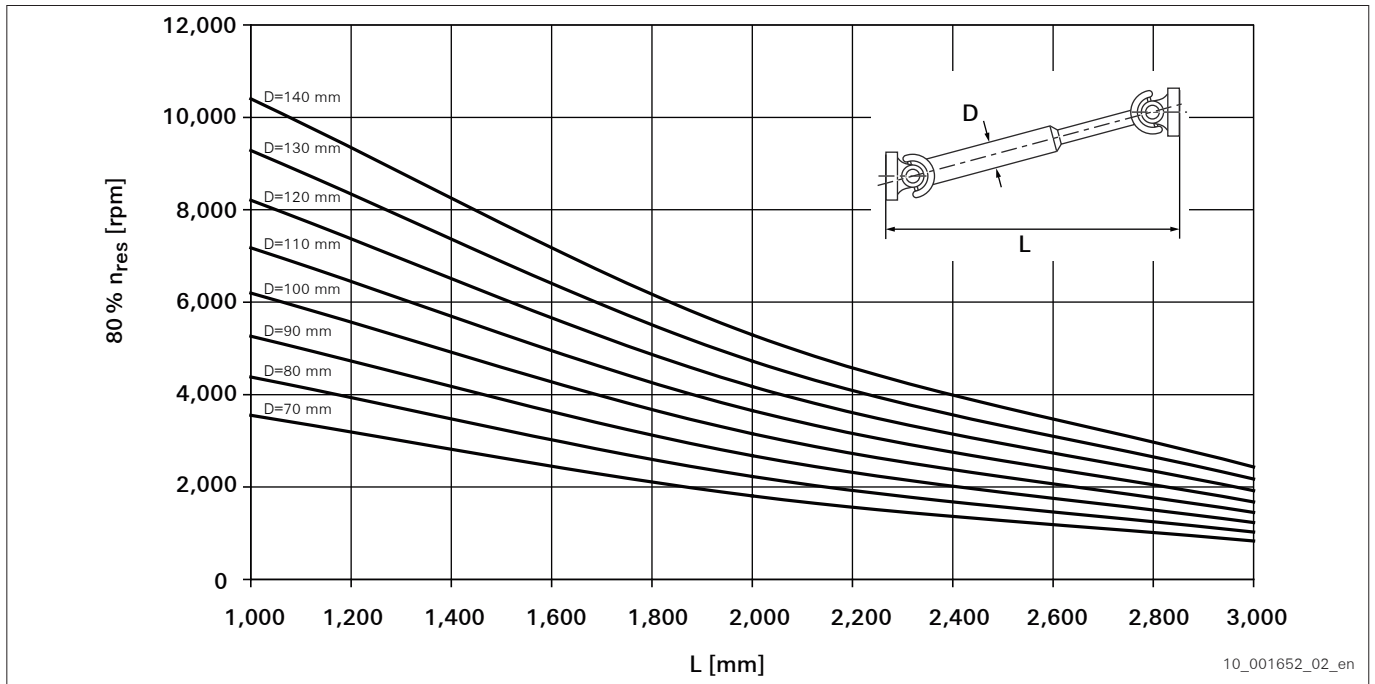

Fig. 44 Maximum permissible propshaft speed for standard steel shafts

7.4.3.5 Balancing the propshaft

The propshaft must be dynamically balanced according to DIN ISO 1940-1 grade 16.

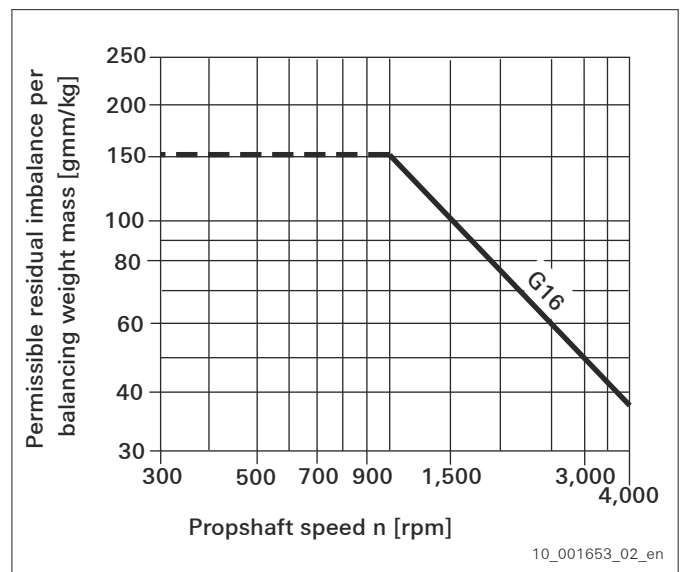

Fig. 45

7.4.3.6 Radial run-out tolerance and axial run-out tolerance of the connecting flanges

For the permissible radial and axial run-out tolerances of the connecting flanges, please refer to ISO 8667.

7.4.3.7 Lubricating the propshaft

Observe the propshaft manufacturer's provisions for lubricating the propshaft.

- It must be ensured that the sliding piece is free-moving under load.

7.4.4 Breather system

For axles AV 110, AV 132II, AV 132II T, AV 133, AV 133 T, pressure compensation of the oil chamber is required.

The axles are available in two versions:

- With installed breather system. No further activities of the vehicle manufacturer are required during installation.
- With connection for a hose breather. The hose breather is not part of the scope of supply and is designed and installed by the vehicle manufacturer.

7.4.4.1 Hose breather

NOTICE

Damage due to water ingress at breather spots possible.

⇒ Comply with specifications for the design and installation of the hose breather.

Two different connections are available.

VOSS plug connection 203.

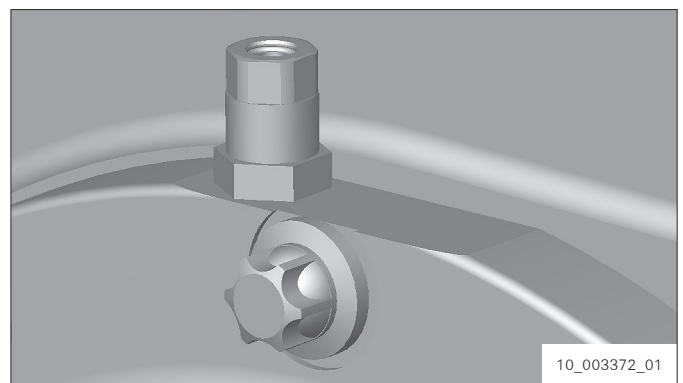

Fig. 46 VOSS plug connection 203

Breather connection with fir-tree profile

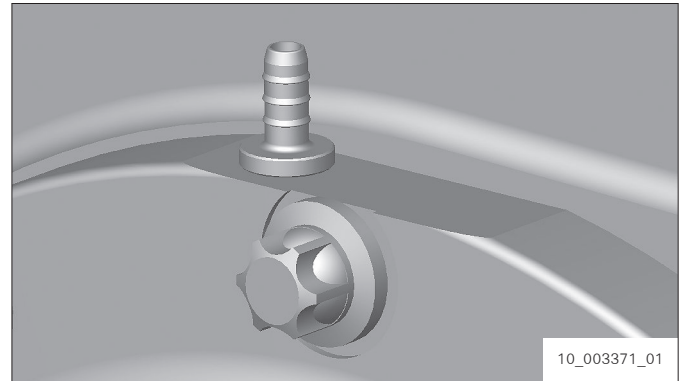

Fig. 47 Breather connection with fir-tree profile

7.4.4.1.1 Design and installation of hose breather



The vehicle manufacturer is responsible for the correct, professional attachment and routing of the breather tube.

Observe when routing and connecting the breather tube:

- **Material and size**
 - Use polyamide tube according to DIN 73378 or DIN 74324.
 - Required diameter: *refer to Installation Drawing*.
- **Connection to axle**
 - The tube end at the connection to the axle must be free from burrs, rectangular and not squeezed. Use cut-off pliers for plastic tube, Voss company, item no. 5994 55 00 00.
 - Fit the breather tube to the axle complying with the provisions (*refer to section Fitting hose breather*).
- **Routing in chassis**
 - The maximum permissible breather tube temperature (e.g. in the area of the exhaust tubes, turbocharger) shall not be exceeded.
 - The breather tube end must be routed to in front of the axle when facing in the direction of travel.
 - The breather tube
 - must be routed from the axle to the longitudinal rod forming a bend of 250^{+50} mm.
 - must be protected against wear using a corrugated tube.
 - must be routed without squeezing, friction and without chafe marks. If required, install spacers to possible contact points.
 - must be routed with the largest possible radius. Kinks are not permitted.
 - must be attached along the longitudinal rod using cable clips.
 - must end in the front area of the wheel housing. The area must be splash-proof and dry (low atmospheric humidity).
 - must end in the chassis at a higher point than the connection at the axle.

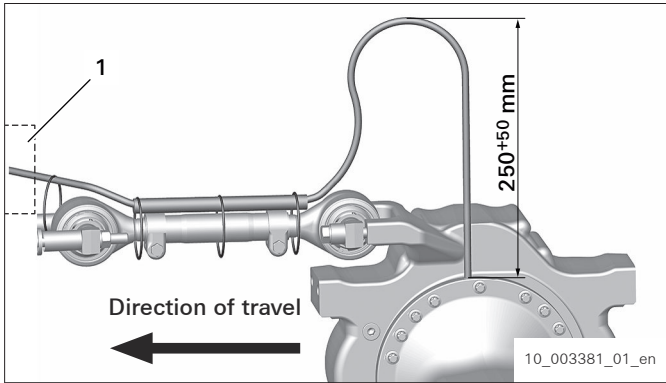

1 Front area of wheel housing

Fig. 48 Vehicle with rear-mounted engine

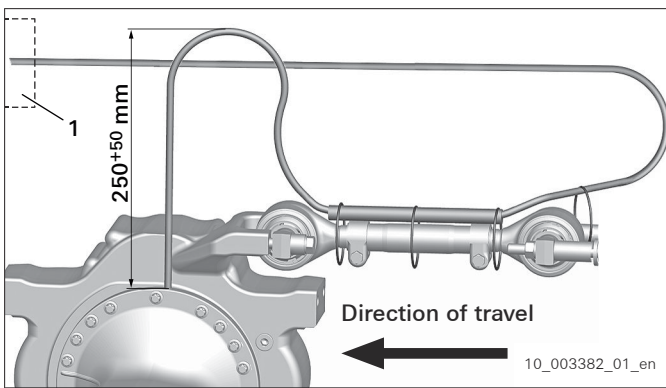

1 Front area of wheel housing

Fig. 49 Vehicle with mid-mounted engine

▪ Tube end design

- Design the tube end in the chassis with an angle of $45^{\circ}+15^{\circ}$.
- Seal the tube end in the through-hole in the chassis.
- Adhere to the minimum distance of the tube end to the chassis. If required, attach a stop (e.g. cable clip) at the breather hose.
- Provide a drain bore in the chassis for condensate, min. \varnothing 16 mm and min. 150 mm away from the tube end.

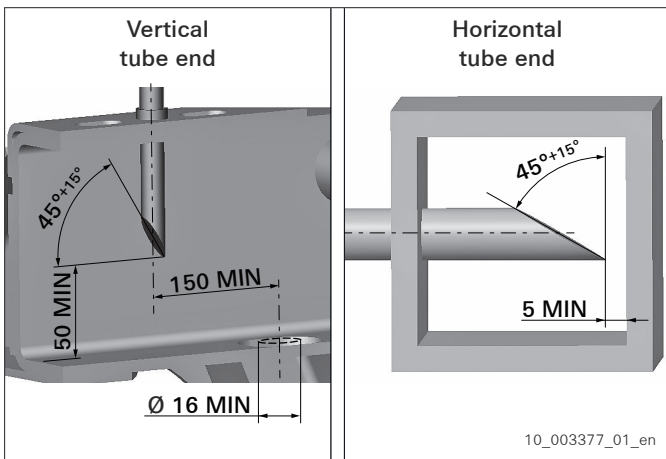

Fig. 50 Tube end design

7.4.4.1.2 Fitting hose breather to VOSS plug connection 203

Requirements:

- VOSS plug connection 203 is attached to the axle.
- Breather tube according to specifications, free of burrs, rectangular, not squeezed.

 The provisions of the manufacturer VOSS Automotive GmbH are binding for installation and operation.

1. Apply two markings at breather tube.
 - Lower marking: 17 ± 1 mm away from tube end
 - Upper marking: 22 ± 1 mm away from tube end
2. Remove mounting plug (1).
3. Put in breather tube into VOSS plug connection 203 until end stop without tools and in correct position.
The lower marking shall no longer be visible after insertion.

 After insertion and retraction, the breather tube can no longer be distorted.

4. Retract breather tube.
Retracting ensures that the retaining edges of the toothed ring (6) mesh with the breather tube.

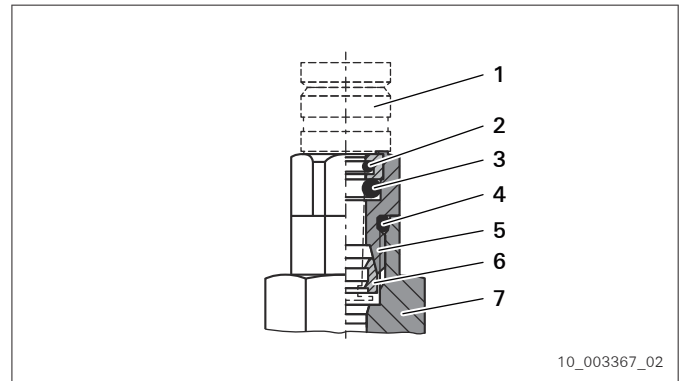



Fig. 51 VOSS plug connection 203

- 1 Mounting plug
- 2 O-ring for dirt seal
- 3 O-ring
- 4 O-ring
- 5 Retaining screw
- 6 Toothed ring
- 7 Connection piece

7.4.4.1.3 Replacing hose breather at VOSS plug connection 203

 The provisions of the manufacturer VOSS Automotive GmbH are binding for installation and operation.

1. Unfasten retaining screw (5).
2. Remove defective breather tube from connection piece (7).
3. Cut off defective breather tube at retaining screw (5). Dispose of retaining screw.
4. Remove and dispose of toothed ring (6).

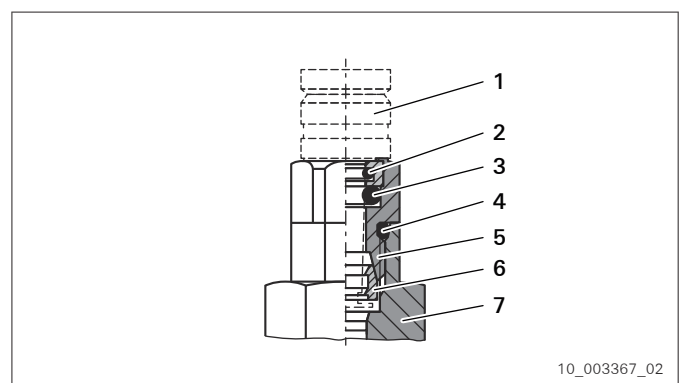

Fig. 52 VOSS plug connection 203

Installation conditions

5. Cut off breather tube according to the specifications (*refer to section Hose breather*).
 6. Fit **new** toothed ring (6) in correct position with tapered side facing upwards.
 7. Screw in **new** retaining screw (5) into connection piece (7) and tighten.
Tightening torque: **5 Nm +1 Nm**
 8. Fit new breather tube (*refer to section Fitting hose breather to VOSS plug connection 203*).
- | | |
|---|----------------------|
| 1 | Mounting plug |
| 2 | O-ring for dirt seal |
| 3 | O-ring |
| 4 | O-ring |
| 5 | Retaining screw |
| 6 | Toothed ring |
| 7 | Connection piece |

7.4.4.1.4 Fitting hose breather at breather connection

Requirements:

- Breather connection is attached to axle.
- Breather tube according to specifications, free of burrs, rectangular, not squeezed.

Special tools:

- AA01.024.845 Assembly pliers
1. Insert breather tube (2) into AA01.024.845 [Assembly pliers] (1) and clamp.

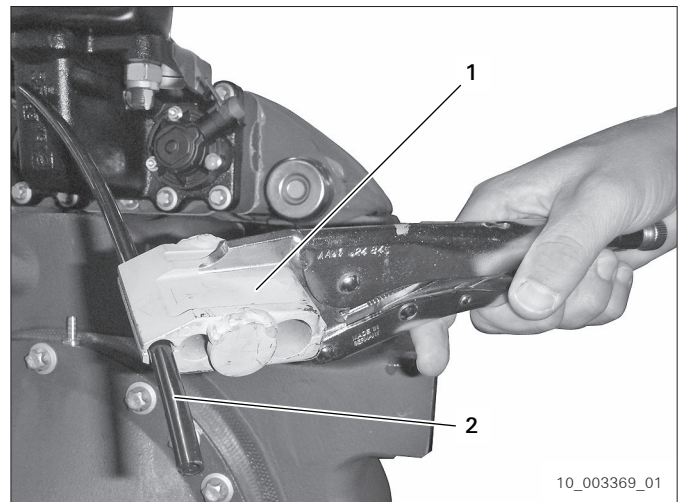

Fig. 53

2. Put breather tube (2) on breather connection (3).
3. Carefully drive in by light blows with a plastic hammer on hitting surface of AA01.024.845 [Assembly pliers] (1) until firmly home.



- Do not heat up breather tube.
- Do not apply lubricants on breather tube or breather connection.

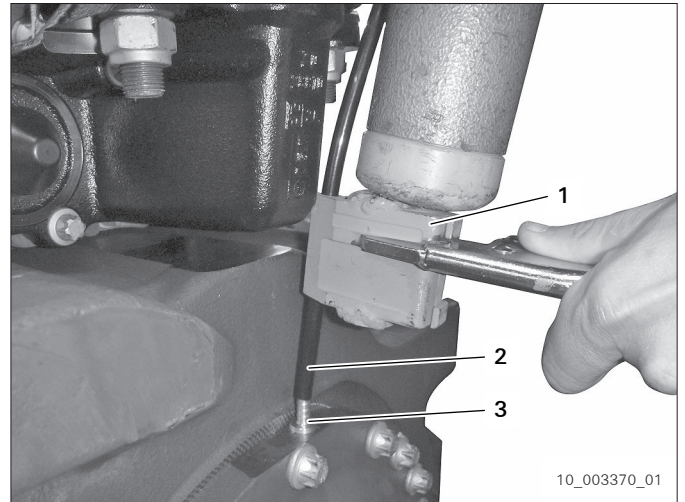

Fig. 54

4. Check that breather tube (1) is firmly home.

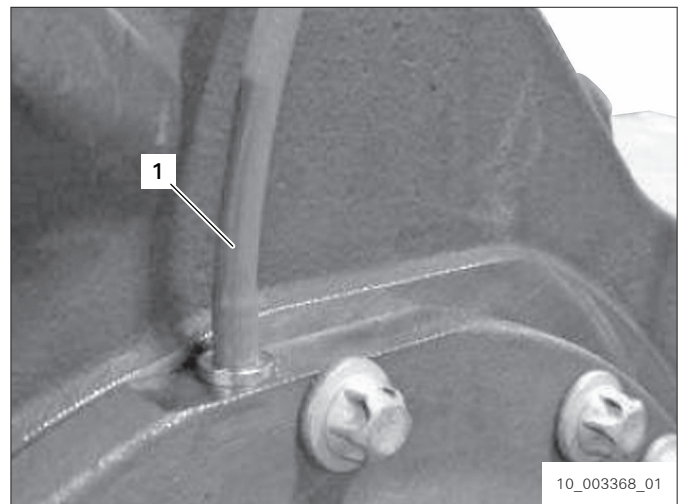

Fig. 55

7.4.4.1.5 Example for correctly routed hose breather

Breather tube is

- protected against wear by a corrugated tube.
- routed forming a large bend to the connection.

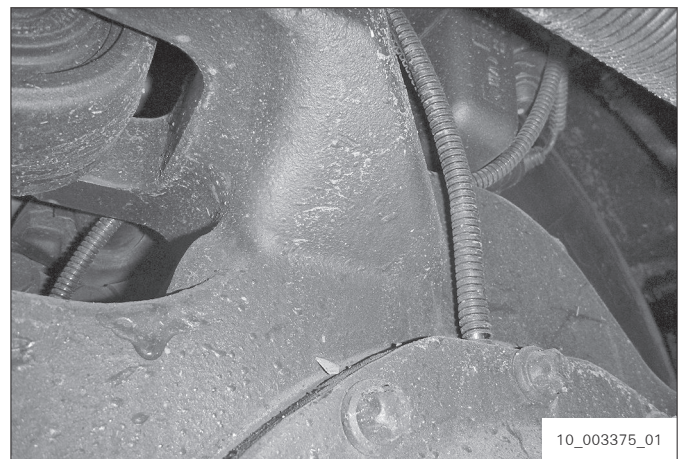

Fig. 56 Correctly routed breather tube

Breather tube is

- protected against wear by a corrugated tube.
- attached to longitudinal rod using cable clips.
- routed to in front of the axle when facing in the direction of travel.

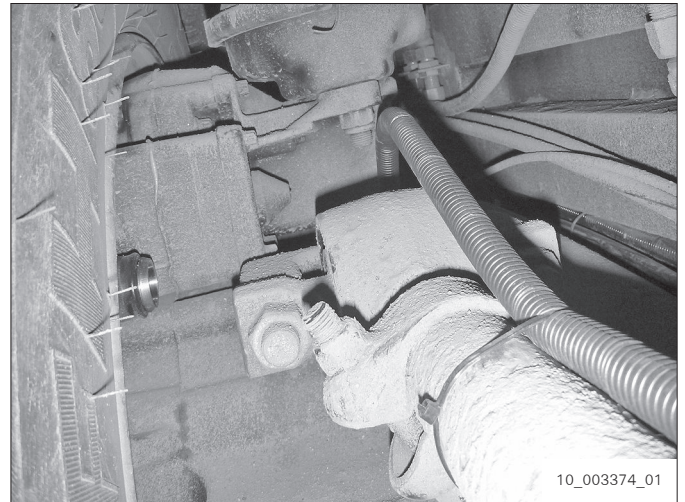

Fig. 57 Correctly routed breather tube

7.4.4.1.6 Example for incorrectly routed hose breather



The routing shall be corrected by the vehicle manufacturer before starting operation. ZF does not assume warranty for damage caused by a deviating installation of the hose breather.

Breather tube was incorrectly routed into splash water area.

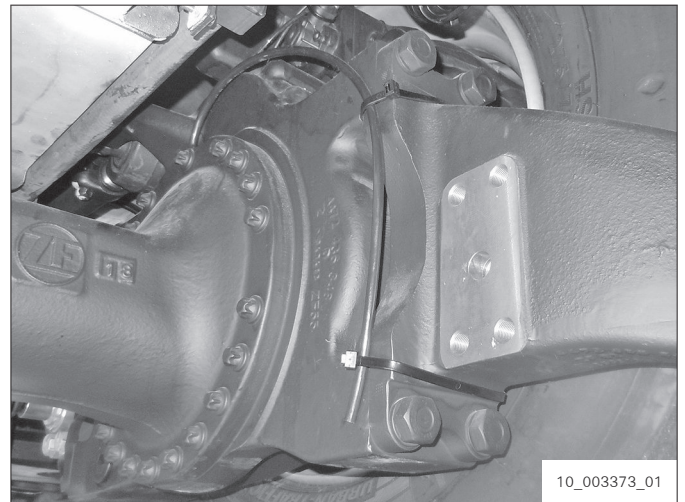

Fig. 58 Incorrectly routed breather tube

Breather tube was

- routed without spacers to possible contact points.
- damaged during operation due to chafe marks.

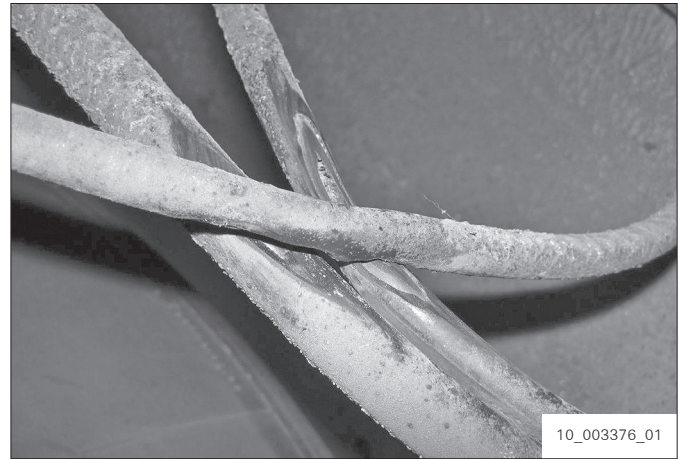

Fig. 59 Incorrectly routed breather tube

7.4.5 Notes on axle driven by an electric motor

These notes apply to ZF axle systems in electrically driven buses

- with serial hybrid drive.
- with parallel hybrid drive.
- with power-split hybrid drive.
- with power supply by an overhead contact line (trolleybus).
- with power supply by batteries.

⚠ WARNING

**Risk of accident due to spinning or blocking wheels.
Death or serious injury possible.**

⇒ The vehicle manufacturer must align the electric motor control with the driver assistance systems.

NOTICE

Damage due to spinning or blocking wheels.

⇒ The vehicle manufacturer must align the electric motor control with the driver assistance systems.

The vehicle manufacturer must align the electric motor control with the driver assistance systems used in the vehicle (e.g., [ABS](#), [EBS](#), [TCS](#)). Too high input torques of the electric motor in traction mode or too high braking torques of the electric motor in coast mode might result in spinning or blocking wheels.

The control software shall be protected against unauthorized changes.

- i** The following notes significantly influence the driven axle's service life. The possibly negative effects in special driving situations in particular might reduce the service life (*refer to section Measures in special driving situations*).

7.4.5.1 Release of application

The following data are required from the vehicle manufacturer for ZF being able to release the application:

- Fully completed questionnaire (*refer to Questionnaire Application file axle systems for commercial vehicles*). On demand, you can obtain the questionnaire from your contact.
- Application profile (topography) and route profile (bus stop distribution), if available.
- Installation drawing with dimensions of the propshaft in vertical and horizontal view.

In case of critical vehicle configurations, further steps must be agreed with ZF.

Using the provided data, ZF will assign the product to a ZF axle system. The data determined and documented in the product assignment are binding for the vehicle manufacturer.

7.4.5.2 Input torque and braking torque of electric motor

The correct application of the electric motor influences

- the vehicle's driving behavior.
- the vehicle's drivability.
- the axle's service life.
- the vehicle's driving safety.

NOTICE

Damage due to torsional vibrations with alternating load possible.

⇒ Alternating load not permissible. Observe provisions.

The following requirements constitute the basis for applying an electric motor:

- Torsional vibrations with alternating load are not permissible.
- Agree the maximally permissible torsional vibrations with ZF and adhere to in any driving condition.
- Torque shock loads are not permissible. Agree the torque change gradient with ZF and adhere to in any driving condition.
- Agree the maximally permissible input capacity and the maximally permissible braking power of the electric motor with ZF.
- The maximally permissible braking torque of the electric motor amounts to about 70% of the maximally permissible input torque of the electric motor. Agree the maximally permissible braking torque of the electric motor with ZF.
- The electric motor's braking torque shall be continuously reduced from the maximally permissible braking torque to 0 Nm when decelerating from about 10 km/h to 5 km/h (*refer to fig. 60, page 61*).
- The maximally permissible input torque and the maximally permissible braking torque of the electric motor must be adhered to in any driving condition.
- Adhere to the engine map released by ZF in any driving condition and protect against unauthorized changes.

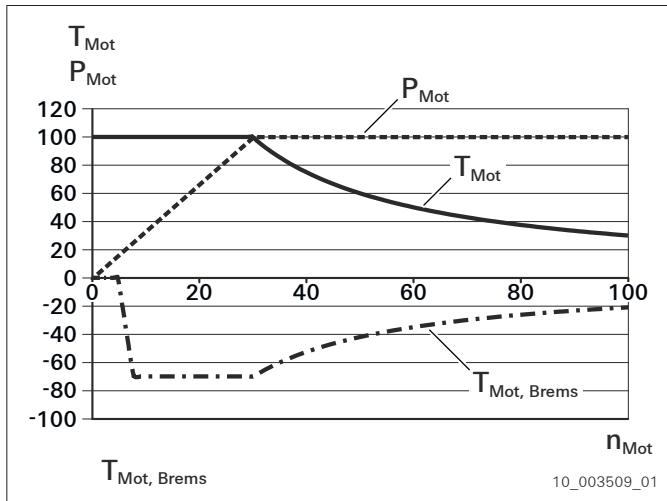

- T_{Mot} Input torque of electric motor [in % of $T_{Mot, max}$]
- $T_{Mot, max}$ Maximum input torque of electric motor
- $T_{Mot, Brems}$ Braking torque of electric motor [in % of $T_{Mot, Brems, max}$]
- $T_{Mot, Brems, max}$ Maximum braking torque of electric motor
- P_{Mot} Input capacity of electric motor [in % of $P_{Mot, max}$]
- $P_{Mot, max}$ Maximum input capacity of electric motor
- n_{Mot} Speed of electric motor [in % of $n_{Mot, max}$]
- $n_{Mot, max}$ Maximum speed of electric motor

Fig. 60 Example: engine map of an asynchronous motor with frequency inverter

7.4.5.3 Measures in special driving situations

7.4.5.3.1 Increasing braking torque by recuperation

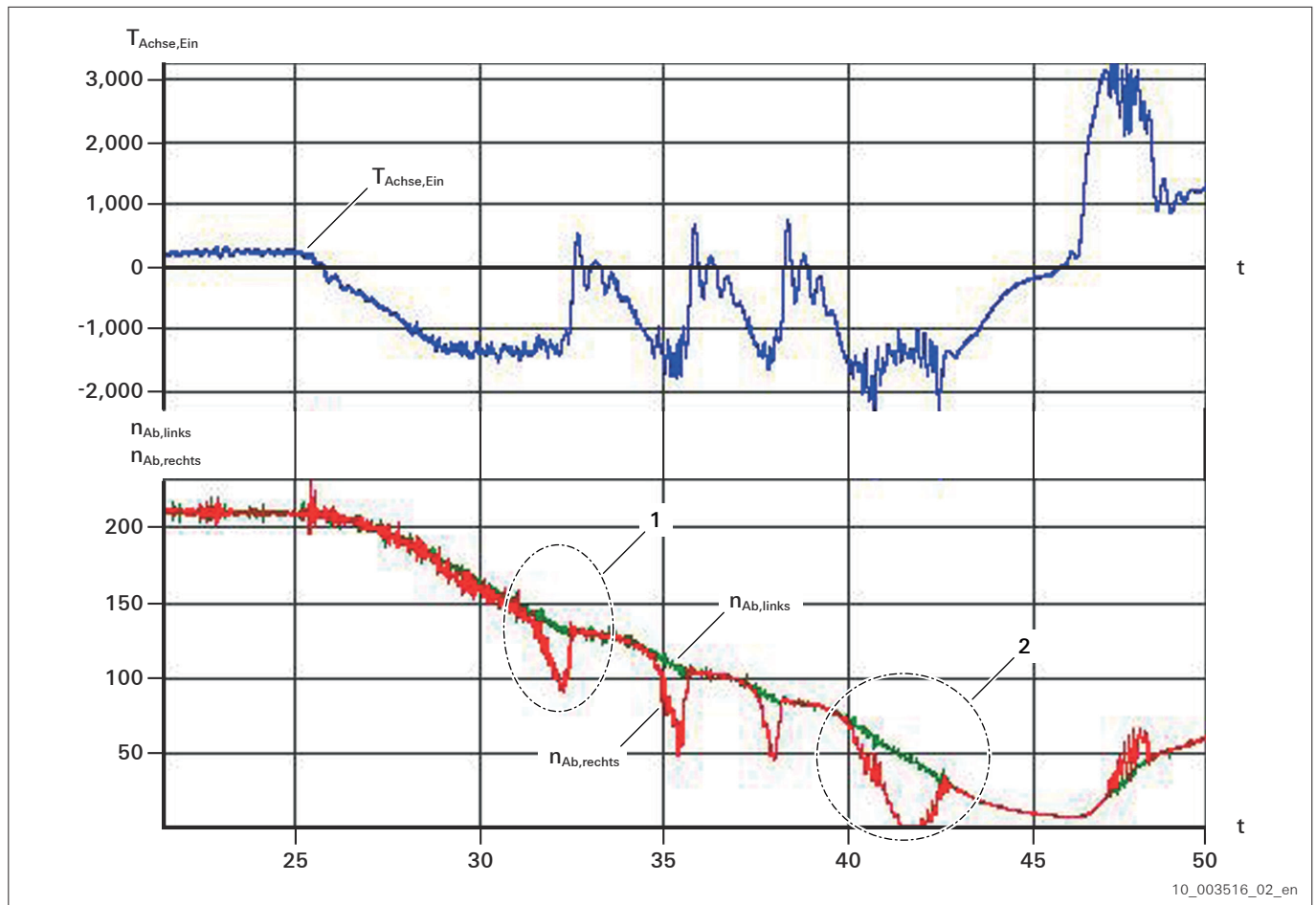

Fig. 61 Example Increasing braking torque by recuperation

$T_{Achse,Ein}$	Torque at axle input [Nm]	t	Time [s]
$n_{Ab,links}$	Output speed left wheel [rpm]	$n_{Ab,rechts}$	Output speed right wheel [rpm]
1	First determined speed differential	2	Standstill of right wheel

Possible occurrence and possible consequences:

- The electric motor's braking torque is increased during recuperation.
- The **ABS** determines a speed differential and reduces the electric motor's braking torque. This operation is repeated until one wheel blocks.

Measures by the vehicle manufacturer:

- Reducing the electric motor's braking torque
 - immediately after the first determined speed differential.
 - depending on the determined negative wheel acceleration.
 - depending on the speed differential across axles (front to rear axle).
- Limiting the electric motor's braking torque for the ongoing recuperation

- depending on the first determined speed differential.
- depending on the actual axle load.

7.4.5.3.2 Torsional vibrations due to ABS intervention

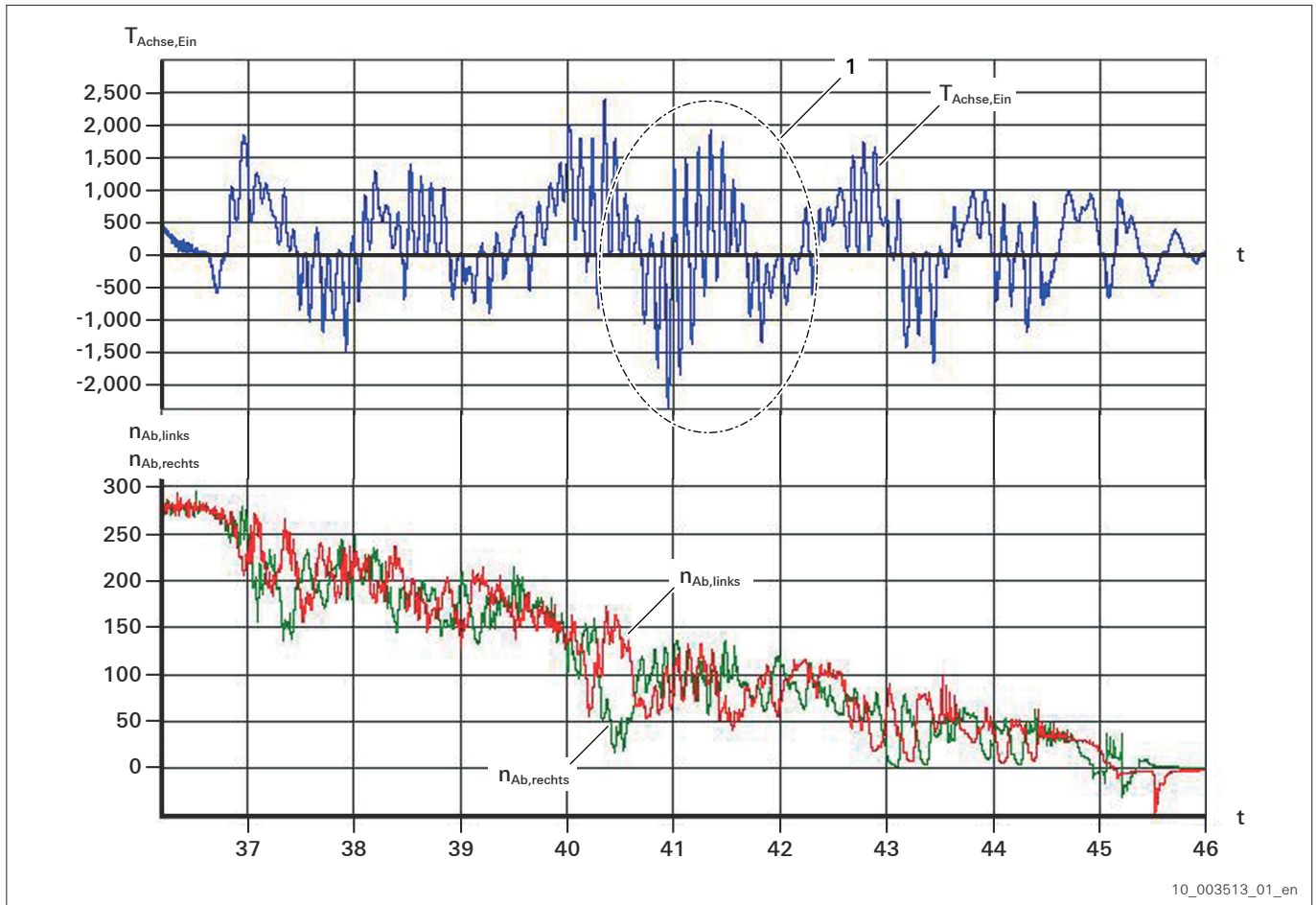

Fig. 62 Example ABS intervention

$T_{Achse,Ein}$	Torque at axle input [Nm]	t	Time [s]
$n_{Ab,links}$	Output speed left wheel [rpm]	$n_{Ab,rechts}$	Output speed right wheel [rpm]
1	Torsional vibrations with alternating load		

Possible occurrence and possible consequences:

- The electric motor's braking torque is suddenly reduced to 0 Nm due to an **ABS** intervention.
- Following the sudden reduction, the driveline faces torsional vibrations with alternating load (zero transition point).

NOTICE

Damage due to torsional vibrations with alternating load possible.

⇒ Alternating load not permissible. Observe provisions.

Installation conditions

Measures by the vehicle manufacturer:

- Preload the driveline during the **ABS** intervention by a low input torque of the electric motor (similar to a bus with Diesel engine and automatic transmission with open clutches).

7.4.5.3.3 Torsional vibrations due to TCS intervention

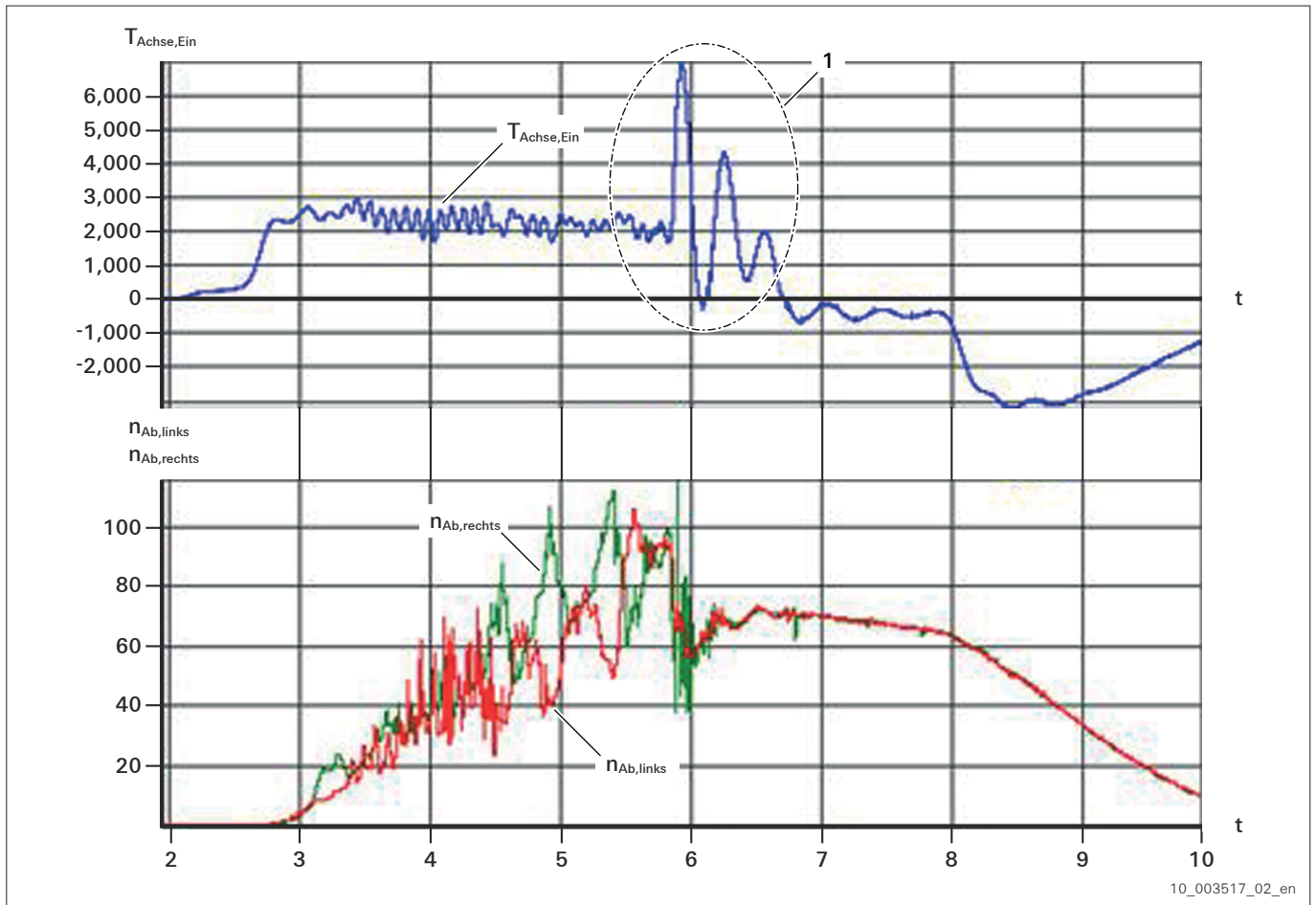

Fig. 63 Example TCS intervention

$T_{Achse,Ein}$	Torque at axle input [Nm]	t	Time [s]
$n_{Ab,links}$	Output speed left wheel [rpm]	$n_{Ab,rechts}$	Output speed right wheel [rpm]
1	Torsional vibrations with alternating load		
	The maximum torque at the axle input is exceeded.		

Possible occurrence and possible consequences:

- Speed differential due to slipping wheels during a hill start.
- The **TCS** intervention by brake intervention is ineffective. The speed differential increases further.
- Due to the increasing speed differential, the driveline faces torsional vibrations with alternating load (zero transition point). The maximally permissible torque at the axle input is exceeded.

NOTICE

Damage due to torsional vibrations with alternating load possible.

⇒ Alternating load not permissible. Observe provisions.

Measures by the vehicle manufacturer:

- Controlling the electric motor's input torque depending on the actual axle load.
- Design the TCS intervention as combination of reducing the input torque and a braking intervention.
- Define the maximally permissible input torque of the electric motor according to the actual requirement.

7.4.5.3.4 Power supply interruption

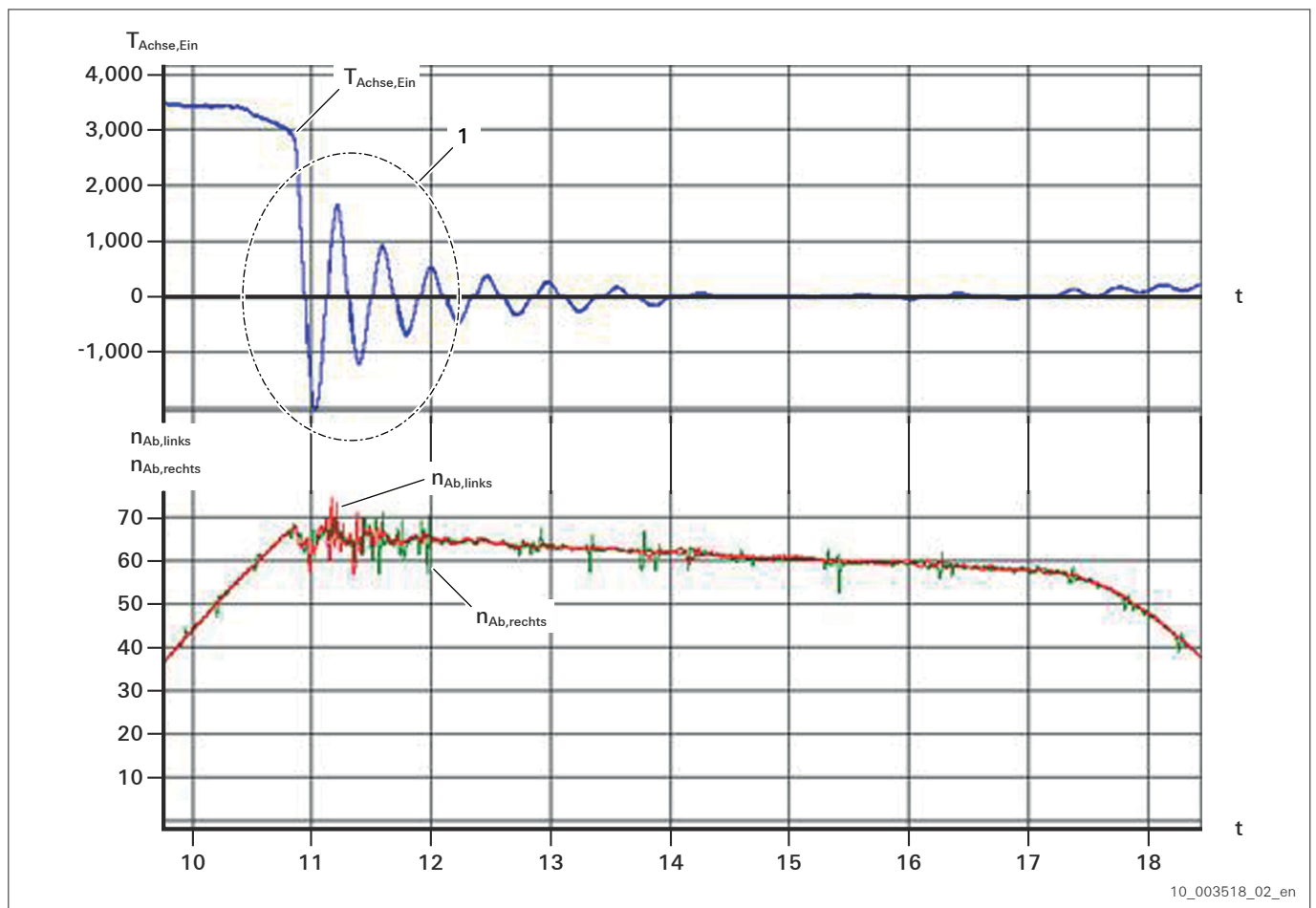

Fig. 64 Example Power supply interruption

$T_{Achse, Ein}$	Torque at axle input [Nm]	t	Time [s]
$n_{Ab, links}$	Output speed left wheel [rpm]	$n_{Ab, rechts}$	Output speed right wheel [rpm]
1	Torsional vibrations with alternating load		

Possible occurrence and possible consequences:

- Sudden torsional vibrations with alternating load due to sudden power supply interruption (e.g. emergency stop, system error, deenergized spot at power supply of an overhead contact line, defective speed sensor at electric motor).

NOTICE

Damage due to torsional vibrations with alternating load possible.

⇒ Alternating load not permissible. Observe provisions.

Measures by the vehicle manufacturer:

- Provide sufficient auxiliary energy and reduce the electric motor's output in a defined way.
- In case of a power supply with overhead contact lines, inform the driver of a deenergized spot in advance.
- Deenergized spots shall not be passed at full speed. Ensure automatic reduction (e.g. reduction of motor output).

7.4.6 Integration of axle AVE 130 into vehicle system

Comply with the specifications for the installation of the cooling system and the integration of the electric motor into the vehicle system (*refer to Installation Instructions 4474.700.135*).

7.5 Brake system

All ZF axle systems are delivered with disk brakes by design. In the following, main criteria are summarized.

 The brake manufacturer's provisions for the installation and operation of the brake disks are binding.

ZF as manufacturer of the axle system cannot influence the service life of brake disks and brake pads. The service life is mainly influenced by the following application conditions:

- Topography of the route.
- Frequency and intensity of braking actions.
- Use of wear-free continuous brake (e.g. retarder).
- Vehicle-dependent brake-force distribution.
- Vehicle-dependent air circulation in the wheel housing (dissipate braking heat).

7.5.1 Brake system design

 ZF recommendation: Before the vehicle manufacturer grants the final release for volume production, the vehicle manufacturer shall perform long-term tests of the brake system in the vehicle.

The following criteria apply for designing the brake system:

- **Compliance with legal provisions, e.g., maximum deceleration for permissible gross vehicle weight, blocking behavior or secondary braking effect.**
The vehicle manufacturer is responsible for testing and release.
- **Calculatory design for empty vehicle state and for full vehicle state.**
The vehicle manufacturer is responsible for testing and release.

- **Brake-force distribution and brake-pressure distribution.**
 - Vehicle with same size of disk brakes and same size of brake chambers at all axles:
Permissible braking-pressure difference between brake circuit 1 and brake circuit 2:
 $\Delta p = \text{maximum } 0.1 \text{ bar.}$
Measure the brake pressure in every brake circuit directly at the brake chamber.
 - Vehicle with different brake design and/or different sizes of disk brakes and/or different sizes of brake chambers at all axles:
The vehicle manufacturer is responsible for testing and release.
- **Temperature measurement for a longer application time.**
 - Vehicle with same size of disk brakes at all axles.
During operation, the same temperature level is to be proven at all disk brakes. At the same temperature level, the disk brakes are evenly stressed.
 - Vehicle with different brake design and/or different sizes of disk brakes and/or different sizes of brake chambers at all axles:
The vehicle manufacturer is responsible for testing and release. The temperature level is defined by the brake design.

7.5.2 Notes on installation and initial operation of brake system

 The vehicle manufacturer is responsible for installing the brake system and taking it into operation.

Brake running clearance

Setting value and setting process: *refer to brake manufacturer's Repair Instructions.*

Brake disk cover

- City bus application:
 - Retrofitting is not permissible.
- Coach application:
 - Retrofitting must be agreed with ZF and released by ZF. The vehicle manufacturer shall measure the temperature beforehand and provide ZF with the measurement results.

Brake pad duct cover

ZF recommendation: If the axles A xxx, AV xxx or AVN xxx are operated with single tires, the brake lining duct must be covered. The dirt thrown off by the rim flange is kept away from the friction surfaces and thus does not lead to increased wear. The brake pad duct covers can be optionally delivered together with the axle.

Brake disk corrosion protection

The brake disks come with short-term corrosion protection that is removed during braking.

WARNING

Risk of accident due to loss of the service brake's braking effect.

Death or serious injury possible.

⇒ Before taking the vehicle into operation, remove the corrosion protection at the brake disks.

Installation conditions



The vehicle manufacturer is responsible for removing the corrosion protection. ZF recommendation: Before taking the vehicle into operation, remove the corrosion protection at the brake disks by cleaning them.

Hillholder function

The use of the hillholder function shall be agreed with ZF. The brake's release time shall be < 0.5 seconds.

Anti-compound valve at spring brake chamber

NOTICE

Damage due to simultaneous actuation of service brake and parking brake possible.

⇒ Install anti-compound valve.

Simultaneous load on the disk brake from service brake pressure and spring actuator force might damage the brake system. Use of overload protection is required.

Fordability

The brake system is not fordable in its delivery state. Traveling through water is prohibited.





The vehicle manufacturer might install the brake system in a fordable manner when taking additional technical measures. The vehicle manufacturer shall be responsible for all changes to the brake system. Observe the brake manufacturer's specifications.

7.5.3 Brake-force distribution

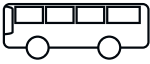

The vehicle manufacturer is responsible for designing the brake-force distribution. When electronic brake systems (EBS) are used, the programming must ensure that the correct brake-force distribution is achieved.

ZF recommendation: The design of the brake system and the compressed air system must be agreed with ZF during the project phase. An early coordination might avoid later changes.

Vehicle with same size of disk brakes at all axles.	Recommended brake-force distribution for brake pressure ≤ 2 bar		
	Axle 1	Axle 2	Axle 3
 Solobus with two axles	1.0	1.0 - 1.1	—
 Solobus with three axles	1.0	1.0 - 1.1	0.7 - 1.0
 Articulated bus with three axles, rear-mounted engine	1.0	1.0	1.1
 Articulated bus with three axles, mid-mounted engine	1.0	1.0	1.0

Tab. 4 Recommended brake-force distribution

Example for a good brake-force distribution
(Solobus with two axles)

- Well harmonized brake-force distribution at both axles.
- Even wear of brake pads at front and rear axle.

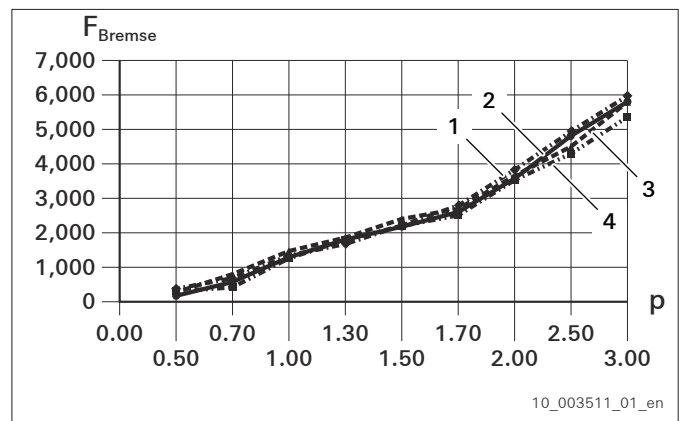

Fig. 65 Example for good brake-force distribution

- F_{Bremse} Brake force [N]
- p Brake pressure at rear axle brake chamber
- 1 Front axle, left
- 2 Front axle, right
- 3 Rear axle, right
- 4 Rear axle, left

Example for a poor brake-force distribution (Solobus with two axles)

- Poorly harmonized brake-force distribution at both axles.
- Excessive brake forces at front axle.
- High wear of brake pads at front axle.
- Low wear of brake pads at rear axle.

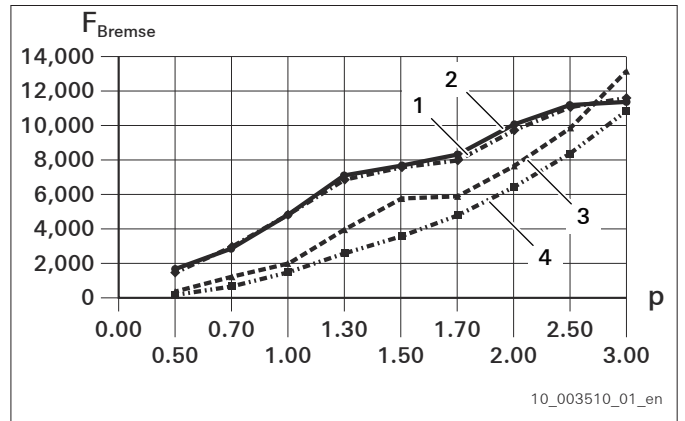

Fig. 66 Example for poor brake-force distribution

F_{Bremse}	Brake force [N]
p	Brake pressure at rear axle brake chamber
1	Front axle, left
2	Front axle, right
3	Rear axle, right
4	Rear axle, left

7.5.4 Retarder integration into brake system

If the retarder request is triggered by the brake pedal position, the full retarder brake effect must be effective for a service brake pressure of more than 0.4 bar.

In city bus applications

- the retarder shall not be switched off.
If the retarder is switched off, the service brake might be thermally overloaded.
- the driver must be informed when the retarder is switched off, e.g., by a warning lamp or a warning signal that is shown in the driver-information system.

7.5.5 Sensors for the antilock braking system

All ZF axle systems are prepared for connecting **ABS** sensors and can be optionally delivered with **ABS** sensors.

Number of teeth of sensor rings for

- wheel size 19.5": 80 teeth.
- wheel size 22.5": 100 teeth.

7.5.6 Brake chamber

Only use brake chambers released by the brake manufacturer and ZF.

 The vehicle manufacturer is responsible for designing and routing the lines.

When routing and connecting the compressed-air lines and sensor lines, observe the following:

- Connect the lines without pressure and strain. Ensure in all operating conditions that the lines
 - do not transmit any compressive forces and tension forces to the brake caliper.
 - do not impair the movability of the brake caliper.
- Route and attach the lines in a protected part of the vehicle. Lines must not be hanging loose.
- The lines shall not be damaged by movements of the axles. Keep sufficiently away from moving parts, e.g., input shaft.
- Attach the lines in such a way that they are neither crimped nor damaged.

7.5.6.1 Spring brake chamber

The vehicle's compressed-air system must provide a sufficiently high pressure to loosen the spring brake chamber under all operating conditions. The minimum pressure required to loosen the spring brake chamber depends on the chamber size.

Chamber size	Minimum pressure required to loosen the spring brake chamber
16"	6.0 bar
24"	6.0 bar
27"	7.0 bar
24HFL1	6.4 bar
24HFL3	7.0 bar

Tab. 5

⚠ WARNING

**Risk of accident due to incorrect installation.
Death or serious injury possible.**

⇒ Observe provisions for installation.

NOTICE

Using non-approved tools and/or a too high tightening torque might lead to damage.

⇒ Tighten by hand.
⇒ Observe tightening torque.

NOTICE

Damage due to insufficient seal possible.

⇒ Observe tightening torque.

Before taking the vehicle into operation, screw in and tighten the caging bolt of the spring brake chamber by hand. Using a pneumatic screwdriver, an impact wrench or a power screwdriver is prohibited.

The tightening torque depends on the spring brake chamber design. Tightening torque: *refer to specifications on the spring brake chamber.*

Installation conditions

A too high tightening torque might damage the spring brake chamber. A too low tightening torque might result in an insufficient sealing of the thread and thus lead to corrosion.

7.5.7 Wear sensing

 Wear sensing serves for information only. The regular visual check of the brake pads is decisive.

 The vehicle manufacturer is responsible for designing and fusing the wiring.

Plugs and electric connections at the brake caliper:

- Protection type IP 67 according to DIN 40050 part 9 or IEC 133
- Close unused plug connections. ZF might deliver suitable sealing plugs.

7.5.7.1 Continuous wear sensing

Continuous wear sensing is ensured by a rotary potentiometer integrated in the brake. The rotary potentiometer is actuated by the brake's adjustment mechanism.

The vehicle manufacturer shall ensure that the rotary potentiometer is supplied with power (in general, 5 V). On demand, you will get the technical data of the rotary potentiometer from your contact.

7.5.7.2 Loop sensing

 The vehicle manufacturer is responsible for electric control and wiring of the loop sensing.

The wear sensing is ensured by a cable integrated in the brake pad. In case of wear, the cable is cut and the electric circuit is interrupted. The driver must be informed when the electric circuit is interrupted, e.g., by a warning lamp or a warning signal that is shown in the driver-information system.

7.6 Wheels

 The vehicle manufacturer is responsible for

- the design of the wheel nut.
- the dimensioning of the tightening torque (e.g. friction coefficient, material, strength class).
- the correct assembly of the wheels.
- determining the regular check of the wheel nut tightening torque.

The vehicle manufacturer must copy these data into the vehicle's operating instructions.

ZF axle systems are designed for wheels with hub centering. Strength class of wheel studs: 10.9.

Observe when dimensioning and assembling the wheels:

- Use wheel nut with pressure plate.
- Use wheel nut of strength class 10.
- Tighten wheel nut with a calibrated torque wrench. Calibration precision $\pm 5\%$.
- Tighten wheel nut to the specified tightening torque.
- The tightening torque specified in the following was calculated for a friction coefficient $\mu_{\text{total}} = 0.09$ to 0.16 (wheel nut, wheel stud and head friction). Adapt tightening torque in case of deviating friction coefficient. Lubrication lowering the friction at the threads is prohibited.
 - M22x1.5 wheel nut
 - for steel wheels with hub centering: 600 Nm.
 - for light-metal wheels with hub centering: according to manufacturer's specifications, however maximum 600 Nm.
 - for steel wheels with bolt centering: according to manufacturer's specifications, however maximum 600 Nm. Use wheels suitable for bolt centering.
 - M20x1.5 wheel nut
 - for steel wheels with hub centering: 500 Nm.
 - for light-metal wheels with hub centering: according to manufacturer's specifications, however maximum 500 Nm.
 - for steel wheels with bolt centering: according to manufacturer's specifications, however maximum 500 Nm. Use wheels suitable for bolt centering.
- Tighten wheel nuts crosswise and by hand in three steps with about 50%, 75% and 100% of the specified maximum tightening torque. Using a pneumatic screwdriver, an impact wrench or a power screwdriver is prohibited.
- Contact point wheel to axle: The contact surface at the axle and the contact surface at the wheel must be clean, dry, free from grease and oil.
- Balancing of wheels
 - Only fit dynamically balanced wheels. Maximum residual unbalance for
 - wheel size 22.5": 50 g/wheel.
 - wheel size 19.5": 50 g/wheel.
 - Balance wheels with wheel balancing machine. On demand, fine-balance the wheels when fit at the vehicle. When balancing at the vehicle, it cannot be identified if the trimming weight must be fit at the inner or outer rim flange.
 - Unbalanced or incorrectly balanced wheels might lead to less comfort.
- Ensure sufficient clearance between wheel and brake. Rotation contour of brake: *refer to Installation Drawing*.
ZF recommendation: Use wheels with outside valve in case of disk brakes (*refer to fig. 67, page 74*).

Installation conditions

ZF recommendation: 15° drop center wheel with outside valve

The valve is located outside of the nave and sufficiently away from the fixed brake caliper.

These types of wheels can also be used for drum brakes.

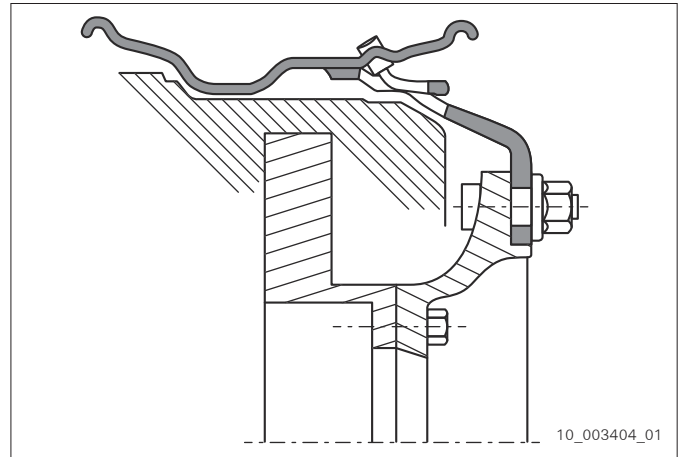

Fig. 67

Not recommended: 15° drop center wheel with inside valve

The valve is located inside the nave. Foreign matter might be caught between fixed brake caliper and rotating valve. The foreign matter might damage or tear off the valve.

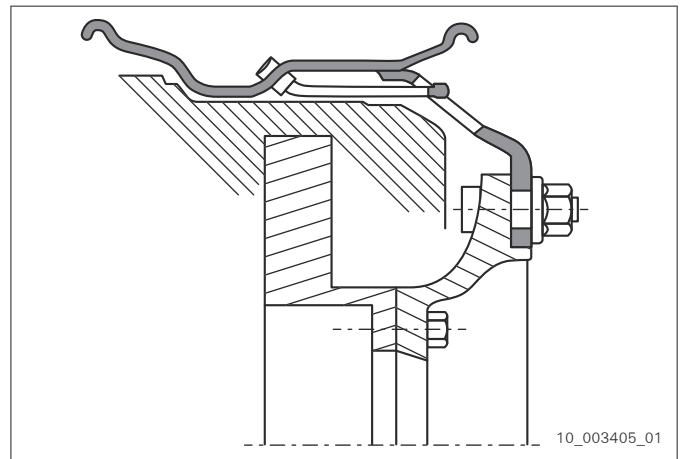

Fig. 68

7.7 Accessibility

The following axle parts must always be accessible for identification, testing, maintenance and repair (the specifications in the Installation Drawing of the axle are binding):

- Type plate.
- Screw plug at oil filling point, screw plug at oil drain.
- Lubricating fittings.

7.8 Corrosion protection

Metal surfaces free of paint are protected

- by anticorrosion oil or grease.
- by adhesive film.

Before installing the axle

- remove anticorrosion oil and grease using a suitable cleaning agent.
- remove adhesive film without leaving any residue.

7.9 Additional brackets

WARNING

Risk of injury due to unauthorized works at ZF product.
Death or serious injury possible.
⇒ Rework at ZF product is prohibited.

Reworking the axle (e.g. drilling, cutting threads, welding) is prohibited. **Failure to comply will void the warranty and functional security will possibly no longer be guaranteed!**

No screw connection on the axle must be unscrewed subsequently in order to, e.g., attach additional brackets.

The application of additional brackets to available housing screw connections is only admissible upon prior consultation of ZF.

7.10 Painting



The vehicle manufacturer is responsible for permanent corrosion protection.

The ZF product is primed when delivered. The vehicle manufacturer shall comply with the specifications for subsequent painting (*refer to section Subsequent painting*).

7.11 Subsequent painting

Before subsequently painting the ZF product, cover the following sliding surfaces and connecting points of the ZF product:

- Input flange.
- Air spring connection.
- Shock absorber connection.
- Stabilizer bar connection.
- Height leveling connection.
- Brakes.
- Wheel studs and contacting points of wheels at wheel head.

Before subsequently painting the ZF product, cover the following parts of the ZF product:

- Breather and hose breather.
- Hoses.
- Shaft sealing rings.
- Plastic parts, like, e.g., bellows of tie rod joints, rubber bearings at rods (longitudinal rods, V-rods, control arms).
- Electric and electronic parts, like, e.g., electronic control units, cables, plugs, plug connections, sensors.
- Type plates.

- Brakes and brake chambers.
- Add-on components, like, e.g., air springs, shock absorbers.

7.12 Underbody protection

Before applying the underbody protection, cover the following sliding surfaces and connecting points of the ZF product:

- Input flange.
- Air spring connection.
- Shock absorber connection.
- Stabilizer bar connection.
- Height leveling connection.
- Brakes.
- Wheel studs and contacting points of wheels at wheel head.

Before applying the underbody protection, cover the following parts of the ZF product:

- Breather and hose breather.
- Hoses.
- Shaft sealing rings.
- Plastic parts, like, e.g., bellows of tie rod joints, rubber bearings at rods (longitudinal rods, V-rods, control arms).
- Electric and electronic parts, like, e.g., electronic control units, cables, plugs, plug connections, sensors.
- Type plates.
- Brakes and brake chambers.
- Add-on components, like, e.g., air springs, shock absorbers.

8 Installation

8.1 Preparatory activities

Before installation

- remove all packaging, protective covers and similar parts from the brake, e.g., at the breather connection.
- remove the corrosion protection.

9 Commissioning

9.1 Before initial operation



The vehicle manufacturer is responsible for complying with the provisions of this Technical Manual and checking them before initial operation.

Check oil level

Check the oil level of the ZF product before taking the vehicle into operation (*refer to Operating Instructions*).

Lubrication of lubricating fittings

Before taking the vehicle into operation, press in grease into all lubricating fittings of the ZF product (*refer to section Grease*).

9.1.1 Checking oil level

Check the oil level of the ZF product before taking the vehicle into operation (*refer to Operating Instructions*).

10 Annex**10.1 Overview of revisions**

Index	Date of issue	Initiator	Chapter	Comment
a	2016-04	TUXD1 Dept.	Document overview Permissible oil temperature Integration of axle AVE 130 into vehicle system	Number of Installation Instructions changed
			Brief product description	A 132: Description changed

Tab. 6

10.2 Subject index

- A**
 ABS sensors, 70
 Accessibility, 74
 Additional brackets, 75
 Air spring, 30
 Air spring by ZF, 30
 Application
 Release, 60
 Auxiliary materials
 General use, 9
- B**
 Brake, 66
 ABS sensors, 70
 Anti-compound valve, 68
 Brake-force distribution, 69
 Brake chamber, 71
 Brake chamber minimum pressure, 71
 Brake disk corrosion protection, 67
 Brake disk cover, 67
 Brake pad duct cover, 67
 Compressed-air line, 71
 Continuous wear sensing, 72
 Design, 66
 Fordability, 68
 Hillholder function, 68
 Loop sensing, 72
 Retarder integration, 70
 Running clearance, 67
 Sensor line, 71
 Spring brake chamber, 71
 Wear sensing, 72
 Breather system, 52
- C**
 Check
 Before initial operation, 78
 Grease, 78
 Oil level, 78
 Checking oil level, 78
 Cleaning, 11
 Corrosion protection, 24, 74
- D**
 Drive by an electric motor, 59
 Braking torque, 60
 Input torque, 60
 Measures in special driving situations, 62
 Release, 60
- E**
 Environmental protection, 9
- G**
 Grease, 18
- H**
 Hose breather, 52, 53
 Fitting, 55, 56
 Replacing, 55
 Hot country application, 20
- I**
 Installation
 Accessibility, 74
 Additional brackets, 75
 Air spring, 30
 Arrangement in the vehicle, 25
 Hose breather, 53, 55, 56
 Longitudinal rod, 26, 27
 Painting, 75
 Positioning axle in chassis, 46
 Preparatory activities, 77
 Remove corrosion protection, 74
 Setting camber, 41
 Setting caster, 41
 Shock absorbers, 28, 29
 Spring carrier, 43
 Stabilizer bar, 32
 Track adjustment, 36
 Underbody protection, 76
 V-rod, 26, 27
 Integration of axle AVE 130, 66
- L**
 List of Lubricants, 18
 Longitudinal rod, 25
 Adjusting, 27
 Installing, 26, 27
 Lubrication of lubricating fittings, 78
- M**
 Measuring toe-in, 36
- O**
 Oil
 Oil purity, 18
 Temperature, 20
 Oil grade, 18

Operating supplies

- General use, 9

P

Painting, 75

- Subsequent painting, 75

Positioning axle in chassis, 46

Preservation, 24

Propshaft, 46

- Balancing, 51

- Connecting flange, 51

- Deflection angle, 47

- Lubrication, 52

- Permissible propshaft speed, 50

- Permissible spatial deflection angles, 50

- Spatial deflection angles, 47, 48

S

Safety instructions

- General safety instructions, 8

- Product-specific, 11

- Signal words, 10

- Symbols, 10

Setting axle geometry, 41

Setting camber, 41

Setting caster, 41

Setting toe-in, 37–39

Shock absorbers, 28

- Joints, 29

- Shock absorbers by ZF, 28

Spring carrier, 43

- Installing, 43

Stabilizer bar, 32

Steering geometry, 34

Steering linkage, 39

Steering spindle, 39

Steering stop, 40

Storage

- Corrosion protection, 24

- Long-term storage, 22

- Preservation, 24

- Short-term storage, 22

T

Temperature

- Hot country application, 20

- Oil temperature, 20

Track adjustment, 36

- Setting toe-in, 39

Track alignment

- Measuring toe-in, 36

- Setting toe-in, 37, 38

Transport

Corrosion protection, 24

General instructions, 21

Preservation, 24

Type plate

- Axle, 19

- Position, 19

U

Underbody protection, 76

V

V-rod, 25

- Adjusting, 27

- Installing, 26, 27

W

Wheel travel limitation

- Compression, 31

- Rebound, 31

Wheels, 73

- Balancing, 73

- Tightening torque, 73

Wiring

- Protection type, 72

10.3 List of abbreviations

ABS	Antilock braking system
EBS	electronic brake system
TCS	traction control system
VCI	volatile corrosion inhibitor

11 Attached Documents

The attached documents are not subject to modification service; they are for information only. Please get in touch with your contact if you need binding documents or drawings.

Document no.	Designation	Technical information
4472.754.101	Checklist	Checklist for installation



AXLES OF A, AV, RL MODEL RANGE CHECKLIST CHECKLIST FOR INSTALLATION

This checklist applies to the following axles:

- A 132, AV 110, AV 132II, AV 132II T, AV 133, AV 133 T, AVE 130, AVN 132
- RL 55 EC, RL 75 A, RL 75 A (NLA), RL 75 E, RL 75 EC, RL 75 EC (NLA), RL 82 EC, RL 85 A, RL 85 A (NLA)

1 Data sheet

Vehicle			
Manufacturer:		Type:	
Model:		Mileage [km]:	
Transmission			
Manufacturer:		Type:	
Model:		Comment:	
Engine			
Manufacturer:		Type:	
Model:		Comment:	
Steering gear			
Manufacturer:		Type:	
Model:		Comment:	
Axle 1			
Parts list [BoM] number:		Installation drawing:	
Axle 2			
Parts list [BoM] number:		Installation drawing:	
Axle 3			
Parts list [BoM] number:		Installation drawing:	
Processing			
Person in charge:		Date:	

Tab. 1 Data sheet



**AXLES OF A, AV, RL MODEL RANGE
CHECKLIST
CHECKLIST FOR INSTALLATION**

2 General

Test characteristics		Yes	No
1.	Lifter available throughout complete vehicle inspection?		
2.	Turn plates available for determination of maximum steering angles?		
3.	Wheel load weighing equipment available?		
4.	Do the vehicle technical data and technical data from the questionnaire match?		
5.	Vehicle close to production and ready for operation?		
6.	Has the steering gear manufacturer approved the steering gear?		
7.	Installation of axles according to Technical Manual 4472.765.101?		
8.	Track adjusted at all vehicle axles?		
9.	Leveling system functioning and correctly set?		
10.	Driveline components adjusted (axle, transmission, engine)?		
11.	Brake-force distribution according to ZF recommendation?		
12.	Bus with three axles: Joint leveling system of axle 2 and axle 3?		

Tab. 2 General

Nur zur Information / For information only



**AXLES OF A, AV, RL MODEL RANGE
CHECKLIST
CHECKLIST FOR INSTALLATION**

3 Axle 1

Test characteristics		Yes	No
13.	Axle correctly installed horizontally?		
14.	Axle correctly installed vertically?		
15.	Toe-in set correctly?		
16.	Installation dimension of shock absorbers correct according to installation drawing?		
17.	Installation dimension of air springs correct according to installation drawing?		
18.	Shock absorbers and air springs protected against heat?		
19.	Length of adjustable longitudinal rods correct?		
20.	Length of adjustable V-rods correct?		
21.	Stabilizer link length correct?		
22.	Additional add-on components installed at axle (e.g. linkage, brackets)?		
23.	Reworks performed at axle (e.g. drilling, cutting threads)?		
24.	Unreleased modifications carried out at axle?		
25.	Welding work performed at axle?		
26.	Brake pad wear sensor connected (if available)? Connection at axle closed, if required?		
27.	ABS connected?		
28.	Collision of axle system (axle, components of axle, add-on components) with chassis?		
29.	Collision of axle system with chassis when steering and/or during spring compression?		
30.	Screws, washers and hexagon nuts of specified strength class used?		
31.	Screws and hexagon nuts tightened with specified tightening torque?		
32.	Protective covers removed, e.g., at breather connection, at brake?		
33.	Cables and compressed-air lines correctly routed?		
34.	Cables and compressed-air lines routed without pressure and tension?		
35.	Corrosion protection at axle correct?		
36.	Leveling system functioning and correctly set?		
Additional test characteristics for RL axles?			
37.	Caster set correctly?		
38.	Camber set correctly?		
39.	Steering linkage installed according to ZF recommendation?		
40.	Steering stop correct?		

Tab. 3 Axle 1



**AXLES OF A, AV, RL MODEL RANGE
CHECKLIST
CHECKLIST FOR INSTALLATION**

4 Axle 2

Test characteristics		Yes	No
41.	Axle correctly installed horizontally?		
42.	Axle correctly installed vertically?		
43.	Toe-in set correctly?		
44.	Installation dimension of shock absorbers correct according to installation drawing?		
45.	Installation dimension of air springs correct according to installation drawing?		
46.	Shock absorbers and air springs protected against heat?		
47.	Length of adjustable longitudinal rods correct?		
48.	Length of adjustable V-rods correct?		
49.	Stabilizer link length correct?		
50.	Additional add-on components installed at axle (e.g. linkage, brackets)?		
51.	Reworks performed at axle (e.g. drilling, cutting threads)?		
52.	Unreleased modifications carried out at axle?		
53.	Welding work performed at axle?		
54.	Brake pad wear sensor connected (if available)? Connection at axle closed, if required?		
55.	ABS connected?		
56.	Collision of axle system (axle, components of axle, add-on components) with chassis?		
57.	Collision of axle system with chassis when steering and/or during spring compression?		
58.	Screws, washers and hexagon nuts of specified strength class used?		
59.	Screws and hexagon nuts tightened with specified tightening torque?		
60.	Arrangement of propshaft correct (<i>refer to Technical Manual 4472.765.101</i>)?		
61.	Protective covers removed, e.g., at breather connection, at brake?		
62.	Cables and compressed-air lines correctly routed?		
63.	Cables and compressed-air lines routed without pressure and tension?		
64.	Corrosion protection at axle correct?		
65.	Leveling system functioning and correctly set?		
Additional test characteristics for AV axles?			
66.	Hose breather correctly installed?		
67.	Oil level checked and oil level correct?		

Tab. 4 Axle 2



**AXLES OF A, AV, RL MODEL RANGE
CHECKLIST
CHECKLIST FOR INSTALLATION**

5 Axle 3

Test characteristics		Yes	No
68.	Axle correctly installed horizontally?		
69.	Axle correctly installed vertically?		
70.	Toe-in set correctly?		
71.	Installation dimension of shock absorbers correct according to installation drawing?		
72.	Installation dimension of air springs correct according to installation drawing?		
73.	Shock absorbers and air springs protected against heat?		
74.	Length of adjustable longitudinal rods correct?		
75.	Length of adjustable V-rods correct?		
76.	Stabilizer link length correct?		
77.	Additional add-on components installed at axle (e.g. linkage, brackets)?		
78.	Reworks performed at axle (e.g. drilling, cutting threads)?		
79.	Unreleased modifications carried out at axle?		
80.	Welding work performed at axle?		
81.	Brake pad wear sensor connected (if available)? Connection at axle closed, if required?		
82.	ABS connected?		
83.	Collision of axle system (axle, components of axle, add-on components) with chassis?		
84.	Collision of axle system with chassis when steering and/or during spring compression?		
85.	Screws, washers and hexagon nuts of specified strength class used?		
86.	Screws and hexagon nuts tightened with specified tightening torque?		
87.	Arrangement of propshaft correct (<i>refer to Technical Manual 4472.765.101</i>)?		
88.	Protective covers removed, e.g., at breather connection, at brake?		
89.	Cables and compressed-air lines correctly routed?		
90.	Cables and compressed-air lines routed without pressure and tension?		
91.	Corrosion protection at axle correct?		
92.	Leveling system functioning and correctly set?		
Additional test characteristics for AV axles?			
93.	Hose breather correctly installed?		
94.	Oil level checked and oil level correct?		
Additional test characteristics for RL axles?			
95.	Caster set correctly?		
96.	Camber set correctly?		
97.	Steering stop correct?		

Tab. 5 Axle 3

ZF Friedrichshafen AG

88038 Friedrichshafen

Deutschland · Germany

Telefon/Phone +49 7541 77-0

Telefax/Fax +49 7541 77-908 000

www.zf.com



MOTION AND MOBILITY