

# SECTION 12: BRAKE AND AIR SYSTEM

## CONTENTS

<b>1. AIR SYSTEM</b>	<b>12-5</b>
<b>2. BRAKES</b>	<b>12-5</b>
<b>3. AIR RESERVOIRS</b>	<b>12-5</b>
3.1 MAINTENANCE	12-5
3.1.1 <i>Wet (Main) Air Tank</i>	12-6
3.1.2 <i>Primary Air Tank</i>	12-6
3.1.3 <i>Accessory Air Tank</i>	12-6
3.1.4 <i>ZF transmission Air Tank</i>	12-6
3.1.5 <i>Secondary Air Tank</i>	12-6
3.1.6 <i>Kneeling Air Tank</i>	12-7
3.2 PING TANK	12-7
<b>4. AIR SYSTEM EMERGENCY FILL VALVES</b>	<b>12-7</b>
<b>5. ACCESSORY AIR FILTER</b>	<b>12-7</b>
5.1 FILTER ELEMENT REPLACEMENT	12-7
5.2 CLEANING	12-7
<b>6. AIR GAUGES (PRIMARY, SECONDARY AND ACCESSORY)</b>	<b>12-8</b>
<b>7. AIR FILTER/DRYER</b>	<b>12-8</b>
7.1 AIR FILTER/DRYER PURGE TANK	12-8
<b>8. AIR LINES</b>	<b>12-8</b>
8.1 COPPER PIPING	12-8
8.2 FLEXIBLE HOSES	12-9
8.3 NYLON TUBING	12-9
8.4 AIR LINE OPERATING TEST	12-9
8.5 AIR LINE LEAKAGE TEST	12-9
8.6 MAINTENANCE	12-9
<b>9. PRESSURE REGULATING VALVES</b>	<b>12-9</b>
9.1 MAINTENANCE	12-10
9.2 PRESSURE SETTING PROCEDURE	12-10
<b>10. AIR COMPRESSOR (BA-921)</b>	<b>12-10</b>
10.1 COMPRESSOR REMOVAL AND INSTALLATION	12-11
<b>11. EMERGENCY/PARKING BRAKE CONTROL VALVE (PP-1)</b>	<b>12-11</b>
<b>12. EMERGENCY / PARKING BRAKE OVERRULE CONTROL VALVE (RD-3)</b>	<b>12-11</b>
<b>13. FLIP-FLOP CONTROL VALVE (TW-1)</b>	<b>12-11</b>
<b>14. DUAL BRAKE APPLICATION VALVE (E-10P)</b>	<b>12-12</b>
14.1 BRAKE PEDAL ADJUSTMENT	12-12

## Section 12: BRAKE AND AIR SYSTEM

---

14.1.1	Maintenance.....	12-12
15.	STOPLIGHT SWITCHES.....	12-12
16.	PARKING BRAKE ALARM SWITCH .....	12-12
17.	BRAKE RELAY VALVE (R-12 & R-14) .....	12-13
18.	QUICK RELEASE VALVES (QR-1).....	12-13
19.	SPRING BRAKE VALVE (SR-7).....	12-13
20.	PRESSURE PROTECTION VALVE (PR-4).....	12-13
21.	LOW PRESSURE INDICATOR (LP-3).....	12-14
22.	SHUTTLE-TYPE DOUBLE CHECK VALVE (DC-4).....	12-14
23.	EMERGENCY DOOR OPENING VALVES .....	12-14
24.	AIR HORN VALVE .....	12-14
25.	AIR SYSTEM TROUBLESHOOTING .....	12-15
26.	BRAKE OPERATION .....	12-15
27.	AIR BRAKES .....	12-15
27.1	DISC BRAKES.....	12-15
27.1.1	Disc Brake Pads.....	12-15
27.1.2	Caliper Maintenance .....	12-16
27.1.3	Roadside Inspection for Knorr/Bendix Air Disc Brakes.....	12-17
27.1.4	Pad Removal.....	12-17
27.1.5	Checking Pad Wear .....	12-18
27.1.6	Important Pad and Rotor Measurements.....	12-18
27.1.7	Checking Caliper Guidance and Seal Condition.....	12-18
27.1.8	Checking the Tappet Boots.....	12-19
27.1.9	Pad Installation.....	12-19
27.1.10	Adjusting the Running Clearance.....	12-19
27.1.11	Brake Tools.....	12-20
27.1.12	Checking Brake Pads.....	12-20
27.1.13	Torque specifications.....	12-20
28.	SAFE SERVICE PROCEDURES .....	12-20
29.	AIR BRAKE TROUBLESHOOTING .....	12-21
30.	BRAKE AIR CHAMBER.....	12-25
30.1	MAINTENANCE.....	12-25
30.2	EMERGENCY/PARKING BRAKE MANUAL RELEASE .....	12-26
30.3	BRAKE CHAMBER REMOVAL.....	12-26
30.4	BRAKE CHAMBER INSTALLATION.....	12-26
30.5	BRAKE CHAMBER DISASSEMBLY .....	12-27

<b>31.</b>	<b>ANTI-LOCK BRAKING SYSTEM (ABS)</b> .....	<b>12-27</b>
31.1	TROUBLESHOOTING AND TESTING .....	12-28
31.2	ABS COMPONENTS .....	12-28
31.2.1	<i>Electronic Control Unit (ECU)</i> .....	12-28
31.2.2	<i>ABS Modulator Valve</i> .....	12-28
31.2.3	<i>Sensors</i> .....	12-29
31.2.4	<i>Sensor Installation</i> .....	12-29
31.2.5	<i>Spring clip</i> .....	12-29
<b>32.</b>	<b>FITTING TIGHTENING TORQUES</b> .....	<b>12-31</b>
<b>33.</b>	<b>SPECIFICATIONS</b> .....	<b>12-32</b>

## ILLUSTRATIONS

FIGURE 1: IFS AIR RESERVOIRS LOCATION .....	12-5
FIGURE 2: I-BEAM FRONT SUSPENSION AIR RESERVOIRS LOCATION.....	12-6
FIGURE 3: REAR VALVE LOCATION (TYPICAL) .....	12-6
FIGURE 4: FRONT SERVICE COMPARTMENT.....	12-7
FIGURE 5: ACCESSORY AIR FILTER .....	12-7
FIGURE 6: HALDEX AIR FILTER DRYER.....	12-8
FIGURE 7: AIR PRESSURE REGULATING VALVE .....	12-10
FIGURE 8: AIR PRESSURE REGULATOR .....	12-10
FIGURE 9: AIR COMPRESSOR LOCATION .....	12-10
FIGURE 10: PP-1 .....	12-11
FIGURE 11: RD-3 .....	12-11
FIGURE 12: TW-1 .....	12-12
FIGURE 13: BRAKE PEDAL ADJUSTMENT .....	12-12
FIGURE 14: DELCO SWITCH .....	12-12
FIGURE 15: BENDIX SWITCH .....	12-12
FIGURE 16: R-12 .....	12-13
FIGURE 17: R-14 .....	12-13
FIGURE 18: QR-1 .....	12-13
FIGURE 19: SR-7 .....	12-13
FIGURE 20: PR-4 .....	12-14
FIGURE 21: LP-3.....	12-14
FIGURE 22: DC-4 .....	12-14
FIGURE 23: THREE-WAY VALVE.....	12-14
FIGURE 24: BRAKE PAD CHECK.....	12-16
FIGURE 25: CLEARANCE INSPECTION .....	12-16
FIGURE 26: RUNNING CLEARANCE .....	12-16
FIGURE 27: ADJUSTER PINION .....	12-17
FIGURE 28: BOX WRENCH ON ADJUSTER PINION .....	12-17
FIGURE 29: CALIPER AXIAL MOVEMENT .....	12-17
FIGURE 30: BRAKE PAD CHECK.....	12-17
FIGURE 31: PAD REMOVAL .....	12-18
FIGURE 32: PAD WEAR .....	12-18
FIGURE 33: ROTOR AND PAD WEAR LIMITS.....	12-18
FIGURE 34: CALIPER GUIDANCE .....	12-19
FIGURE 35: RUBBER BOOTS .....	12-19
FIGURE 36: PAD INSTALLATION .....	12-19
FIGURE 37: RUNNING CLEARANCE .....	12-20

## Section 12: BRAKE AND AIR SYSTEM

---

FIGURE 38: BRAKE PAD CHECK .....	12-20
FIGURE 39: TORQUE SPECIFICATION .....	12-20
FIGURE 40: TORQUE SPECIFICATION .....	12-20
FIGURE 41: AIR-OPERATED BRAKING SYSTEM FOR X3 COACHES EQUIPPED WITH I-BEAM AXLE FRONT SUSPENSION .....	12-22
FIGURE 42: AIR-OPERATED BRAKING SYSTEM FOR X3 COACHES EQUIPPED WITH INDEPENDENT FRONT SUSPENSION .....	12-23
FIGURE 43: FRONT AXLE BRAKE AIR CHAMBER.....	12-25
FIGURE 44: TAG AXLE BRAKE AIR CHAMBER.....	12-25
FIGURE 45: ABS ECU LOCATION .....	12-28
FIGURE 46: ABS MODULATOR VALVE .....	12-28
FIGURE 47: ABS SENSOR LOCATION .....	12-29
FIGURE 48: SPRING CLIP .....	12-29
FIGURE 49: ABS 4S/4M CONFIGURATION .....	12-30
FIGURE 50: HOSE FITTINGS .....	12-31
FIGURE 51: HOSE FITTING .....	12-31
FIGURE 52: HOSE FITTING .....	12-31
FIGURE 53: HOSE FITTING .....	12-31

**1. AIR SYSTEM**

The basic air system consists of an air compressor, reservoirs, valves, filters and interconnecting lines and hoses. It provides a means for braking; operating controls and accessories, and suspension (refer to Section 16, "Suspension", for complete information on suspension description and maintenance). An air system schematic diagram is annexed in the technical publications box provided with the vehicle for better understanding of the system.

**2. BRAKES**

This vehicle uses both the service brake and emergency/parking brake. The service brake air system is divided into two independent circuits to isolate front brakes from rear brakes, thus providing safe braking in the event that one circuit fails. Front axle brakes operate from the secondary air system, while brakes on both the drive axle and tag axle operate from the primary air system.

**NOTE**

*The tag axle service brake operates only when the axle is in normal ride position (loaded and down).*

Furthermore, the brake application or release, which is speed up by a pneumatic relay valve (R-12), will start with the rear axles and will be followed by the front axle, thus providing uniform braking on a slippery road. The vehicle is also equipped with an Anti-Lock Braking System (ABS), which is detailed later in this section.

The drive and tag axles are provided with spring-loaded emergency/parking brakes, which are applied automatically whenever the control valve supply pressure drops below 40 psi (275 kPa).

**3. AIR RESERVOIRS**

The air coming from the air dryer is first forwarded to the wet air tank, then to the primary (for the primary brake system), secondary (for the secondary brake system), and accessory (for the pneumatic accessories) air tanks (Fig. 1 & 2).

Two additional air reservoirs may be installed on the vehicle: the kneeling air tank and ZF transmission air tank.

**3.1 MAINTENANCE**

Ensure that the wet (main) air tank is purged during pre-starting inspection. In addition, it is good practice to purge this reservoir at the end of every working day. The remaining reservoirs must be purged at every 12,500 miles (or 20 000 km) or once every year, whichever comes first.

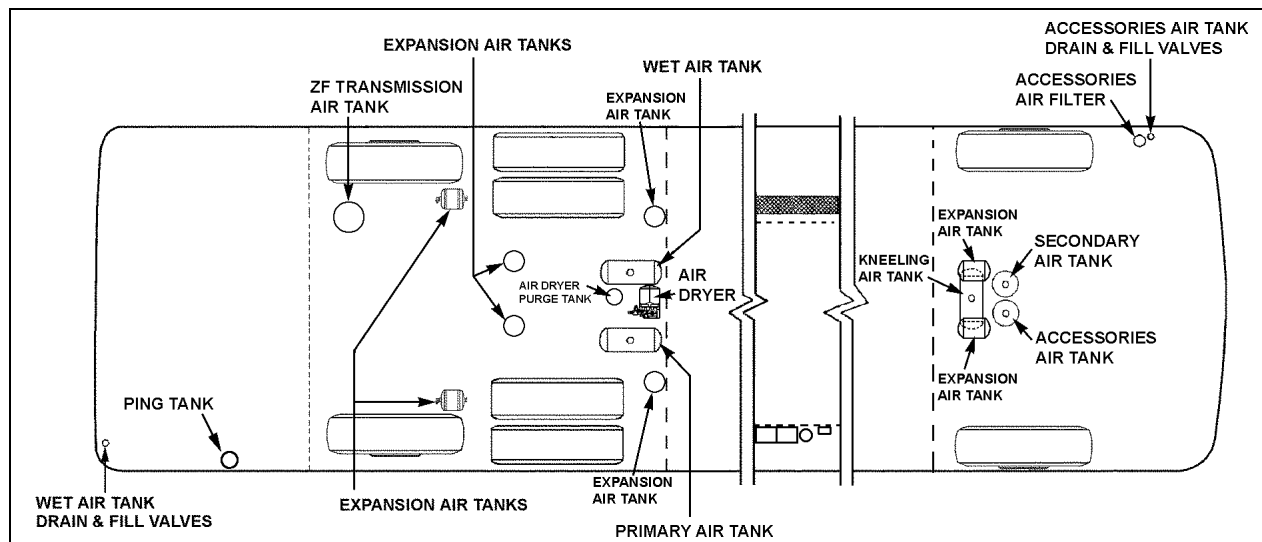

FIGURE 1: IFS AIR RESERVOIRS LOCATION

12212

## Section 12: BRAKE AND AIR SYSTEM

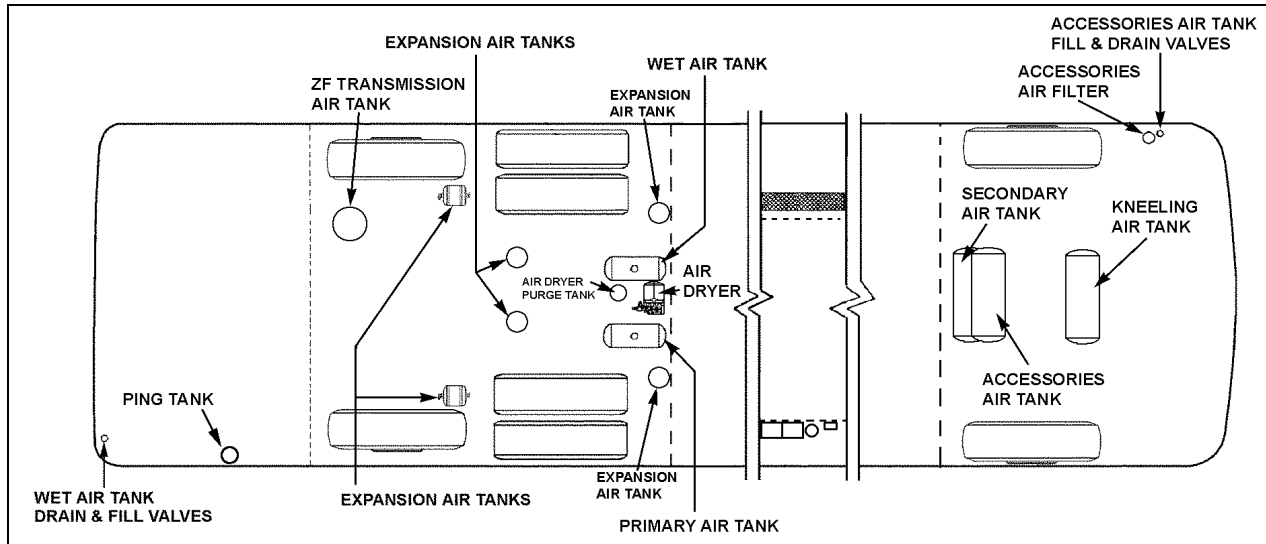

FIGURE 2: I-BEAM FRONT SUSPENSION AIR RESERVOIRS LOCATION

12213

### 3.1.1 Wet (Main) Air Tank

This reservoir, located above the L.H. wheel of drive axle in the rear wheelhousing, is provided with a bottom drain valve. A recommended purge using the bottom drain valve should be done every 12,500 miles (20 000 km), or once a year, whichever comes first.

### 3.1.2 Primary Air Tank

This reservoir is located above the R.H. wheel of the drive axle and is provided with a bottom drain valve (Fig. 1 & 2). It is recommended to purge the primary air tank every 12,500 miles (20 000 km) or once a year, whichever comes first.

### 3.1.3 Accessory Air Tank

The accessory air tank is installed close to the front axle and is provided with a bottom drain valve (Fig. 1 & 2).

Purge the reservoir by it's drain valve every 12,500 miles (20 000 km) or once a year, whichever comes first.

### 3.1.4 ZF transmission Air Tank

Installed on vehicles equipped with this option, this reservoir is located in the rear wheelhousing, beside the transmission on the L.H. side of the vehicle (Fig. 1 & 2). It is provided with a bottom drain valve.

Purge this reservoir every 12,500 miles (20 000 km) or once a year, whichever comes first.

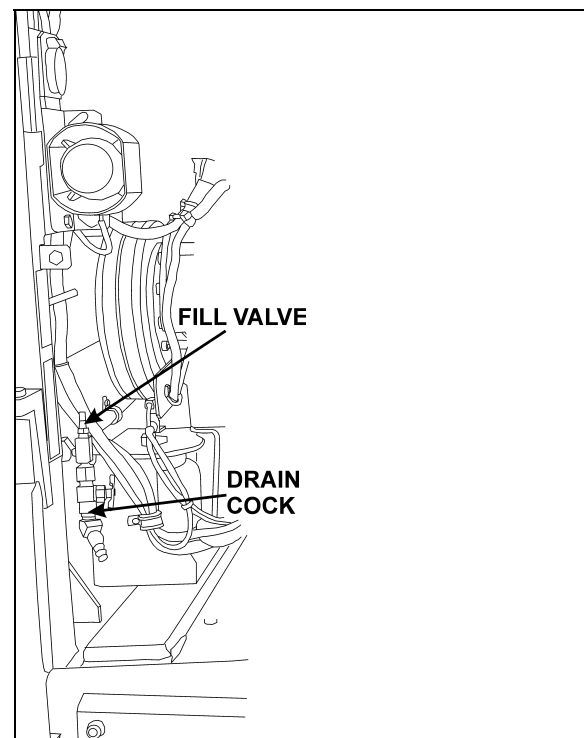

FIGURE 3: REAR VALVE LOCATION (TYPICAL)

12211

### 3.1.5 Secondary Air Tank

This tank is located in the front wheelhousing, behind the steering axle (Fig. 1 & 2). It is provided with a bottom drain valve.

Purge this reservoir every 12,500 miles (20 000 km) or once a year, whichever comes first.

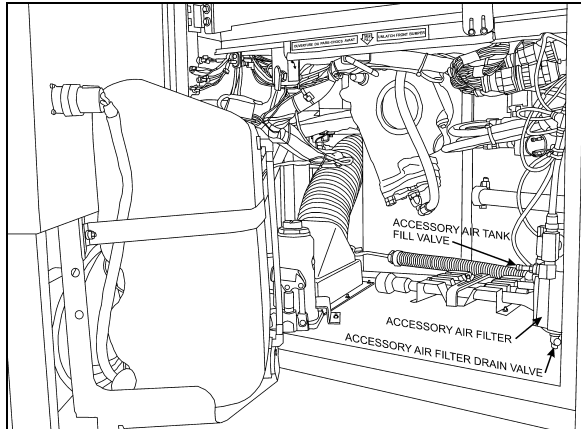

FIGURE 4: FRONT SERVICE COMPARTMENT 12210

### 3.1.6 Kneeling Air Tank



The kneeling air tank is installed on vehicles equipped with the Kneeling or Hi/Low-Buoy options. It is located in the front wheelhousing (Fig. 1 & 2), and is provided with a bottom drain valve.

### 3.2 PING TANK

The ping tank may be located behind the tag axle or in the engine compartment; in this case, it is accessible through the engine compartment R.H. side door. It is used to dissipate heat and to reduce noise produced by the air compressor cycling on and off.

## 4. AIR SYSTEM EMERGENCY FILL VALVES

All vehicles come equipped with two emergency fill valves that enable system pressurization by an external source such as an air compressor. The rear valve is located in the engine compartment and is accessible from engine R.H. side door (Fig 3). It is positioned close to the door opening.

 <b>CAUTION</b> 
<p><b>Maximum allowable air pressure is 125 psi (860 kPa). Air filled through these two points will pass through the standard air filtering system provided by Prevost. Do not fill system by any point on the system.</b></p>

The front valve is located in the front service compartment close to R.H. side of door frame (Fig. 4).

These two air system emergency fill valves are fitted with the same valve stems as standard tires, and can be filled by any standard external air supply line.

The rear air system emergency fill valve will supply air for all systems (brakes, suspension and accessories) while the front fill valve will supply air for accessories only.

## 5. ACCESSORY AIR FILTER

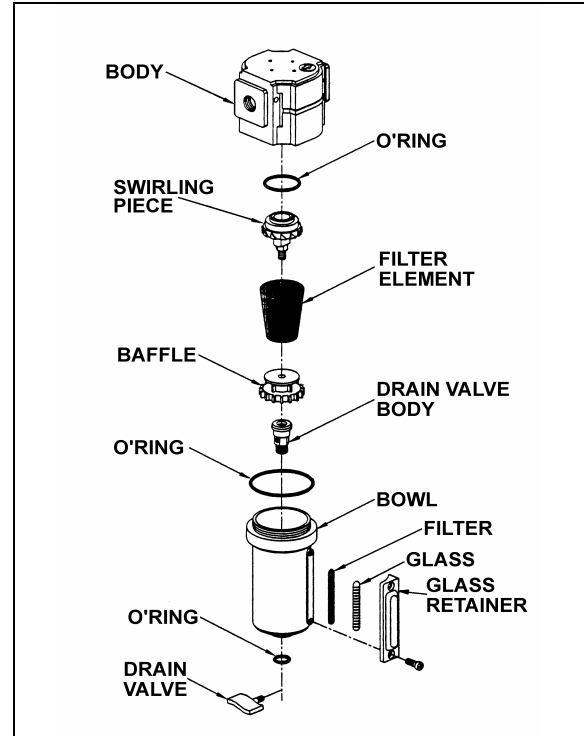

FIGURE 5: ACCESSORY AIR FILTER 12088

This filter is located inside the front service compartment (Fig. 4). Its main function consists in filtering the air supplied to the accessory air system, when connected to an external supply line. Ensure filter is purged whenever supplying the system with an external air line and at least every 12,500 miles (20 000 km). To purge, open drain valve (Fig. 4), let the moisture come out, then close the drain valve.

### 5.1 FILTER ELEMENT REPLACEMENT

Replace filter element whichever of the following occurs first: every 100,000 miles (160 000 km), every two years, or whenever differential pressure exceeds 15 psi (105 kPa) between filter inlet and outlet ports. Check condition of all three O-rings for damage. Replace when necessary (Fig. 5).

### 5.2 CLEANING

Clean filter body and bowl with a warm water and soap solution. Rinse thoroughly with clean water. Blow dry with compressed air making

## Section 12: BRAKE AND AIR SYSTEM

sure the air stream is moisture free and clean. Pay particular attention to the internal passages. Inspect all parts for damage and replace if necessary.

### 6. AIR GAUGES (PRIMARY, SECONDARY AND ACCESSORY)

The air pressure gauges, located on the dashboard (see *"Operator's Manual"*), are connected to the DC-4 double check valve, located on the pneumatic accessory panel in the front service compartment.

The latter is connected to the air lines running from the primary and secondary air tanks, as shown on the pneumatic system diagram provided in the technical publications box. The accessory air gauge is connected to the accessory air tank using the drain valve connector. The vehicle should never be set in motion until the buzzer alarm and warning lights turn off, i.e. when air pressure registers at least 66 psi (455 kPa). Moreover, if pressure drops below 66 psi (455 kPa), the *"Low air pressure"* warning lights will turn on, and the *"Low air pressure"* buzzer will sound. Stop the vehicle immediately, determine and correct the cause(s) of pressure loss. Check the gauges regularly with an accurate test gauge. Replace the gauge with a new unit if there is a difference of 4 psi (27 kPa) or more in the reading.

### 7. AIR FILTER/DRYER

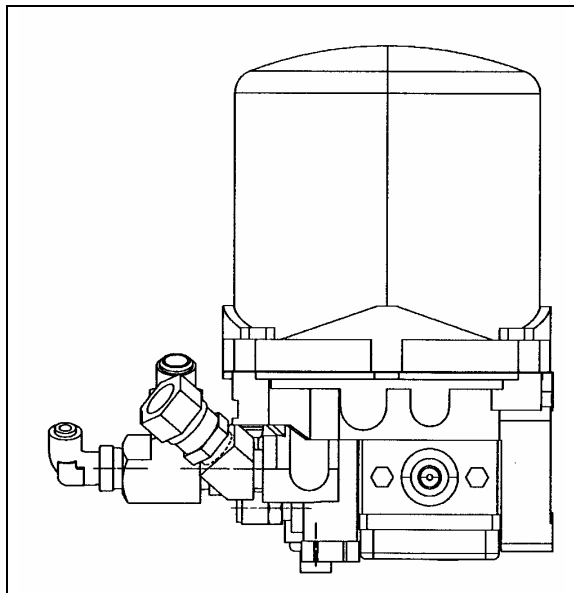

FIGURE 6: HALDEX AIR FILTER DRYER

12194

The air filter/dryer is located in front of rear wheelhousing above drive axle (Fig. 1, 2 & 6). Its purpose is to remove moisture that could damage the air system before the air enters the system reservoir. The air filter/dryer also filters the air to remove dirt, compressor oil, and other contaminants that can damage the system. Change cartridge every 100,000 miles (160 000 km) or once every two years, whichever comes first. The air dryer may be purged for maintenance purposes using the remote drain valve located in the engine compartment and accessible through the engine compartment R.H. side door. The valve is positioned close to the L.H. side of door opening (Fig. 3). The air filter/dryer has a built-in governor to maintain the system between 108 psig and 123 psig.

Maintenance and repair information is supplied in the maintenance information annexed to this section.

#### 7.1 AIR FILTER/DRYER PURGE TANK

A tank is supplied to purge the air filter/dryer to remove moisture and contaminants.

### 8. AIR LINES

Copper piping, nylon-reinforced tubing, and flexible hoses are used to connect the units in the pneumatic system, including air brake system, suspension system and accessory systems such as the entrance door, fresh air damper cylinder, air horns, etc. Furthermore, the nylon tubing is color coded to ease identification. Refer to the following table for the complete color identification code. Service instructions for each type of air line are also provided under the applicable headings.

Color	Circuit
Red	Secondary
Green	Primary and Delivery
Yellow	Parking Brake
Blue	Suspension
Black	Accessory
Brown	Trailer Brake

#### 8.1 COPPER PIPING

A heat dissipation copper piping assembly is used to dissipate the heat coming from the compressor before it enters the air filter/dryer.



Connections should be checked for leakage at least every 6,250 miles (10 000 km) or twice a year, whichever comes first. Tighten or replace when necessary. When replacing copper piping, the parts must be free of burrs, copper cuttings, and dirt. Blow out piping with compressed air. Any such particles will destroy sealing seats in air control units. Also, new piping must be the same size as the old one.

### 8.2 FLEXIBLE HOSES



A flexible hose is used normally where it is impractical to use copper or nylon tubing due to constant flexing during operation, such as brake chamber hoses. Hose connections should be tested for leakage at least every 6,250 miles (10 000 km) or twice a year, whichever comes first and tightened or replaced if necessary. Any hose which is chafed, worn or kinked should be replaced.

Teflon-braided stainless steel hoses used in the engine compartment must be replaced only with similar hoses.

### 8.3 NYLON TUBING

Nylon tubing is used for air lines in areas where usage of this material is suitable. Nylon tubing is flexible, durable, and weather resistant. When replacing an air line, use nylon tubing only where it has been used previously.

Nylon air lines must never be routed in areas where temperature could exceed 200°F (93°C).

 <b>CAUTION</b> 
<p><b>Nylon air lines should be used to replace existing nylon lines only, and must comply with the color identification code to ease pneumatic system troubleshooting.</b></p>

### 8.4 AIR LINE OPERATING TEST

If any trouble symptom such as slow brake application or slow brake release indicates a restricted or clogged air line, disconnect the suspected tube or hose at both ends and blow through it to clear the passage.

Inspect tubing and hose for partial restriction that may be caused by dents or kinks. If such a condition is found, the tubing or hose should be replaced.

### 8.5 AIR LINE LEAKAGE TEST

With air system fully charged and the brakes applied, coat all tubing and hose connections with a soapy solution to check for air leakage. No leakage is permitted. Leakage can sometimes be corrected by tightening the connection. If this fails to correct the leakage, new fittings, nylon tubing, copper tubing, teflon-braided stainless steel and flexible hoses must be installed as applicable.

### 8.6 MAINTENANCE

Inspect all lines for cuts, swelling, kinks or other damage or deterioration. Check for lines being pinched by other components. Retaining clips and ties must be in place.

Any support or bracket should be in good condition and mounted firmly in position. Hose spring guards should be in usable condition and not distorted. Particular attention should be given to long lines. Any supporting component (clips, ties, grommets, etc.) must be secured to prevent against unnecessary vibration and eventual loosening of connection. Any detected leak should be repaired. Be sure nylon lines are not near areas of intense heat. Check for any missing grommets or loose material where chafing or cutting may occur. Replace with new material as required. In general, lines should be securely located in position and free from any binding condition which would hinder air flow.

## 9. PRESSURE REGULATING VALVES

There is one pressure regulator for the belt tensioners, and an optional one installed on vehicles equipped with the World transmission output retarder.

The belt tensioner pressure regulating valve is located in the engine compartment above the doors and is used to limit the air pressure in belt tensioners to 50 ± 2 psi (345 ± 15 kPa) (Fig. 7).

The optional regulator is located near the Webasto in the engine compartment (accessible through the engine R.H. side door). It is used for transmission retarder and should be adjusted to 80 ± 3 psi (550 ± 20 kPa).

	Air Pressure (psi)	Air Pressure (kPa)
Belt Tensioner	<b>Series 60</b> 50	<b>Series 60</b> 345
Retarder	80 ± 3	550 ± 20

## Section 12: BRAKE AND AIR SYSTEM

### 9.1 MAINTENANCE

Every 100,000 miles (160 000 km) or once every two years, whichever comes first, disassemble the regulating valve and wash all metal parts in a cleaning solvent (Fig. 7). Examine the diaphragm; if cracked, worn or damaged, replace with a new one. If the valve is excessively grooved or pitted, it should be replaced. Replace any other part that appears worn or damaged. After reassembly, adjust to the specified pressure setting and check for air leakage.

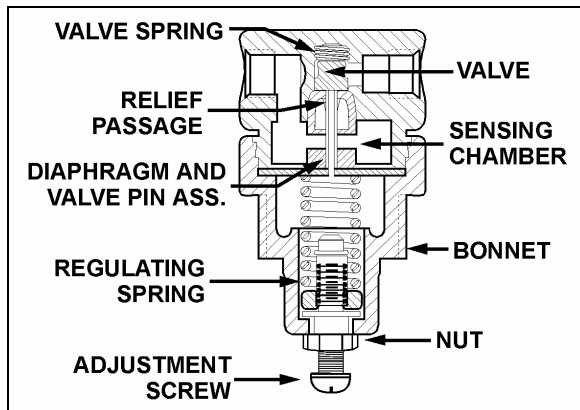

FIGURE 7: AIR PRESSURE REGULATING VALVE 12141B

### 9.2 PRESSURE SETTING PROCEDURE

Remove the dust cap from the pressure check valve (Fig. 8). Attach a pressure gauge at this port and check the pressure reading. If the pressure reading is incorrect, adjust as follows:

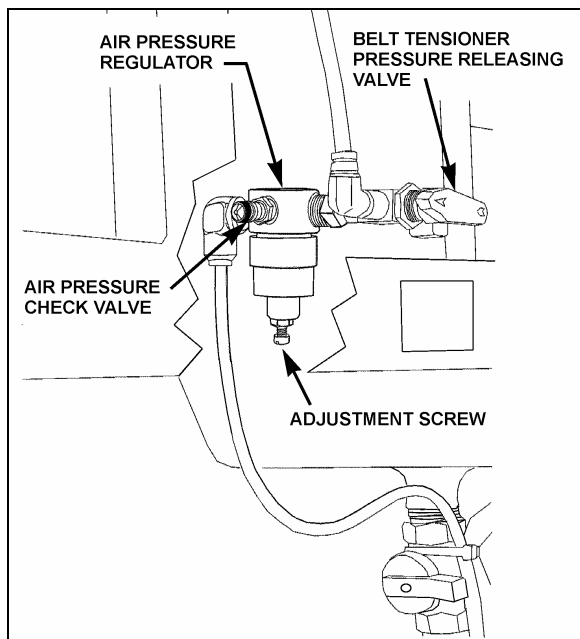

FIGURE 8: AIR PRESSURE REGULATOR 12200

1. Loosen the locking nut, turn the adjustment screw counterclockwise to decrease pressure by approximately 10 psi (70 kPa) below the required pressure.
2. Turn the adjustment screw clockwise to increase the pressure slowly until the required pressure setting is reached. Tighten the locking nut.
3. Remove pressure gauge and replace dust cap on the air pressure check valve.

### 10. AIR COMPRESSOR (BA-921)

The air compressor is located on starter side of the engine, on the rear of the engine gear case (Fig. 9). Its function is to provide and maintain air under pressure to operate devices in brake and air systems.

This air compressor also drives the engine fuel pump which is bolted to the rear end of the compressor. The compressor crankshaft is designed to accept a drive coupling which is placed between the compressor and fuel pump.

The compressor is driven by the bull gear, and is water cooled. Engine coolant is fed to the compressor through a flexible hose tapped into the block water jacket and connected to the rear of the compressor. Coolant returns from the top of the compressor (governor side) through a flexible hose to the engine pump.

The air is taken from the air intake manifold and entered in the top of the compressor. The compressed air is pushed into the discharge line located on side of the compressor, which sends air to the air dryer. Lubricating oil is supplied to the compressor by a line from the cylinder block oil gallery connected to the air compressor. Lubricating oil returns to the engine crankcase through the air compressor drive assembly.

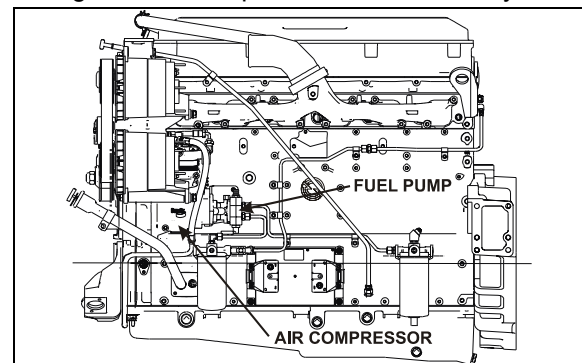

FIGURE 9: AIR COMPRESSOR LOCATION 03061

Maintenance and repair information on the Bendix BA-921 air compressor is supplied in the applicable booklet annexed to this section under reference number SD-01-676.

**10.1 COMPRESSOR REMOVAL AND INSTALLATION**

1. Exhaust compressed air from air system by opening the drain valve of each air tank.
2. Drain the engine cooling system. See Section 5: "Cooling System".
3. Identify and disconnect all air, coolant and oil lines from the compressor assembly.
4. Access the compressor by the engine R.H. side compartment. Remove the four compressor mounting bolts and the two fuel pump support bracket bolts.
5. Slide air compressor rearward to disengage the hub from coupling. Remove the air compressor.

Reverse removal procedure for installation.

**11. EMERGENCY/PARKING BRAKE CONTROL VALVE (PP-1)**

A push-pull control valve mounted on the L.H. lateral console is provided for parking brake application or release. The spring brakes are self-actuated whenever the control valve supply pressure drops below 40 psi (275 kPa). In the UP position, brakes are ON. In the DOWN position, brakes are RELEASED. A protective case around the knob prevents accidentally releasing the brakes.

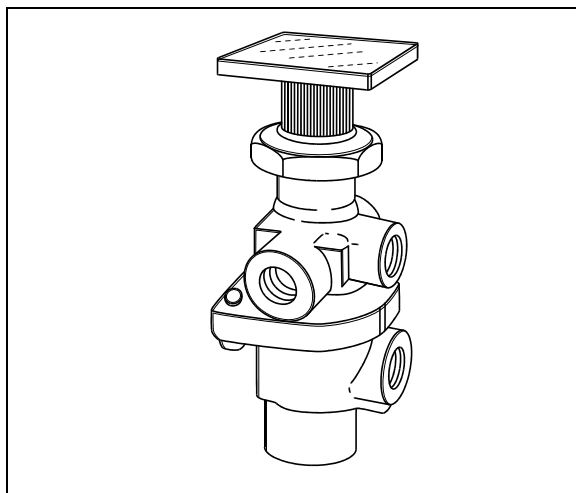

**FIGURE 10: PP-1** 12142

Maintenance and repair information on this valve is supplied in the applicable booklet annexed to

this section under reference number SD-03-3611.

Remove the valve the following way:

1. Drain the air system.
2. Access this valve by tearing out the finishing panel, which holds the controls in place (Fig. 10).
3. Disconnect the air tubes.
4. Remove the retaining screws.
5. Service or replace the valve.
6. Installation is the reverse of removal.

**12. EMERGENCY / PARKING BRAKE OVERRULE CONTROL VALVE (RD-3)**

A RD-3 control valve is used with the optional parking brake overrule system. In the case of self-application of spring brakes due to a pressure drop, the brakes can be released by holding down this control valve. Maintenance and repair information on this valve is supplied in the applicable booklet annexed to this section under reference number SD-03-3611.

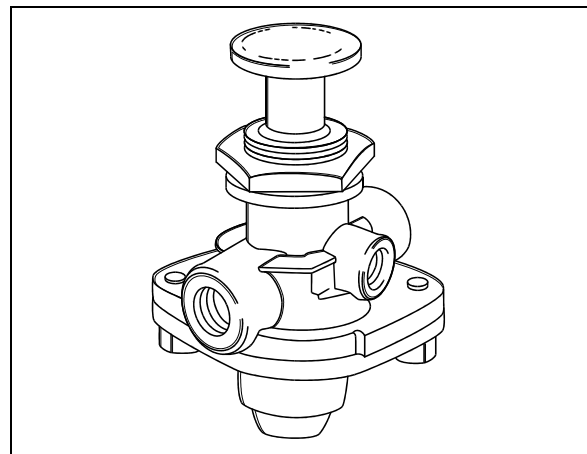

**FIGURE 11: RD-3** 12136

**13. FLIP-FLOP CONTROL VALVE (TW-1)**

A flip-flop control valve mounted on the L.H. lateral console is provided to unload tag axle air springs (and to lift tag axle if vehicle is so equipped). Another one controls the low-buoy system (coaches only). It is a manually operated "on-off" valve. Maintenance and repair information on this valve is supplied in the applicable booklet annexed to this section under reference number SD-03-3602.

## Section 12: BRAKE AND AIR SYSTEM

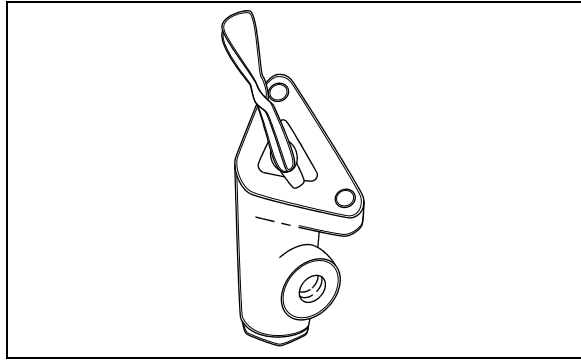

FIGURE 12: TW-1

12138

### 14. DUAL BRAKE APPLICATION VALVE (E-10P)

The E-10P dual brake valve is a floor mounted, foot-operated type brake valve with two separate supply and delivery circuits. This valve is located in the front service compartment (Fig. 13).

#### 14.1 BRAKE PEDAL ADJUSTMENT

After brake pedal replacement or repair, adjust the pedal to its proper position according to the following procedure:

1. Replace the linkage, loosen threaded rod lock nuts and screw or unscrew the threaded adjustment rod in order to obtain a 45° brake pedal inclination (Fig. 13).
2. Tighten threaded rod lock nuts.

##### 14.1.1 Maintenance

Maintenance and repair information on the E-10P dual brake application valve is supplied in the applicable booklet annexed to this section under reference number SD-03-830.

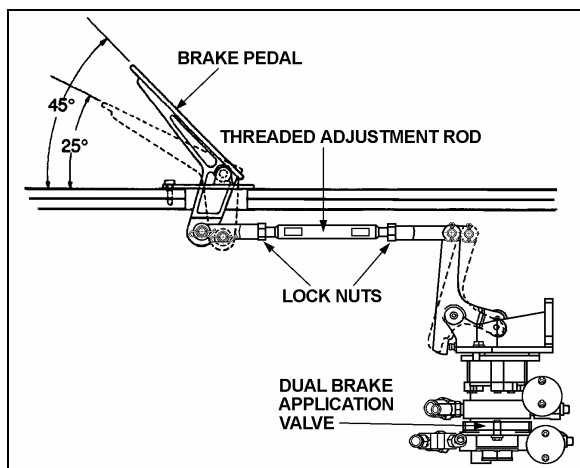

FIGURE 13: BRAKE PEDAL ADJUSTMENT

12208

### 15. STOPLIGHT SWITCHES

Two electro-pneumatic stoplight switches are mounted on the dual brake application valve (E-12). The upper one is used for the primary air circuit while the lower one is used for the secondary air circuit. Both switches are connected in parallel and have the same purpose, i.e. completing the electrical circuit and lighting the stoplights when a brake application is made. The upper switch (AC Delco) is designed to close its contact between 2 psi and 4 psi (14 kPa to 28 kPa) (Fig. 14), while the lower one (Bendix, SL-5) closes its contact at 4 psi (28 kPa) (Fig. 15). The switches are not serviceable items; if found defective, the complete unit must be replaced.

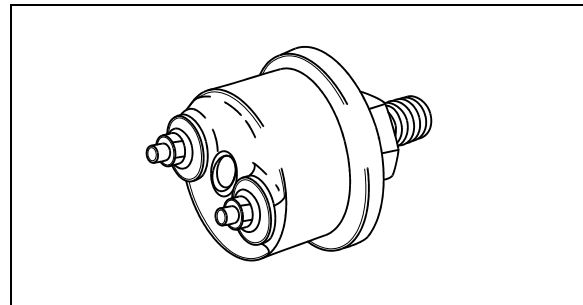

FIGURE 14: DELCO SWITCH

12139

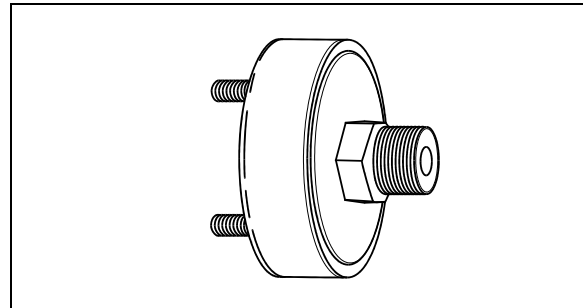

FIGURE 15: BENDIX SWITCH

12140

### 16. PARKING BRAKE ALARM SWITCH

Refer to the appropriate annexed booklet (Bendix, SL-5 Stop Light Switch; reference no. SD-06-2501).

The parking brake alarm uses the same switch as the stoplights. It is mounted on the spring brake valve and operates in conjunction with a NC relay to sound a warning alarm by completing the electrical circuit when the ignition key is turned OFF with parking brake released.

**17. BRAKE RELAY VALVE (R-12 & R-14)**

The primary air system includes three brake relay valves being supplied by the dual brake valve, and which function is to speed up the application and release of the service brakes.

One Wabco R-14 valve located in the rear underframe supplies the drive axle service brake air line, while the other two R-12 valves supply independently both the tag axle right and left service brake air line and act as interlock valves. These valves are accessible from under the vehicle at the level of the tag axle. Maintenance and repair information on these valves is supplied in the applicable booklet annexed to this section under reference number SD-03-1064.

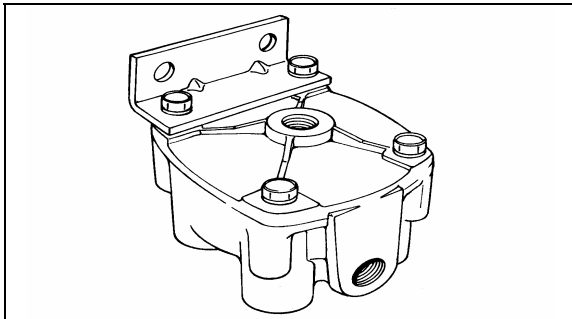

FIGURE 16: R-12 12074

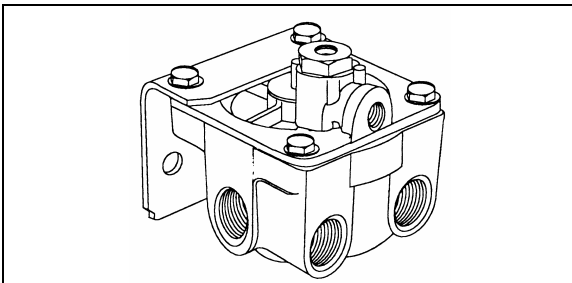

FIGURE 17: R-14 12207

**18. QUICK RELEASE VALVES (QR-1)**

The quick release valve is located on the front axle service brakes air line and permit rapid exhaust of air pressure from brakes, thus decreasing the brake release time.

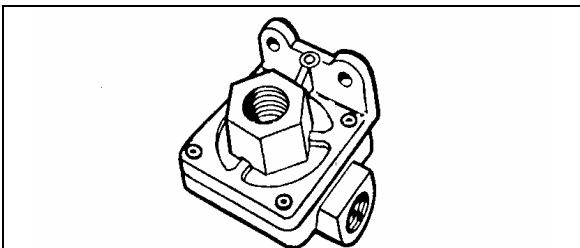

FIGURE 18: QR-1 12075

Maintenance and repair information on this valve is supplied in the applicable booklet annexed to this section under reference number SD-03-901.

**19. SPRING BRAKE VALVE (SR-7)**

The spring brake valve is located in the rear underframe. The SR-7 Modulating Valve is used in conjunction with a dual air brake system and spring brake actuator and performs the following functions:

- Provides a rapid application of the spring brake actuator when parking.
- Modulates the spring brake actuator application using the dual brake valve should a primary failure occur in the service brake system.
- Prevents compounding of service and spring forces.

Maintenance and repair information on the spring brake valve is supplied in the applicable booklet annexed to this section under reference number SD-03-9043.

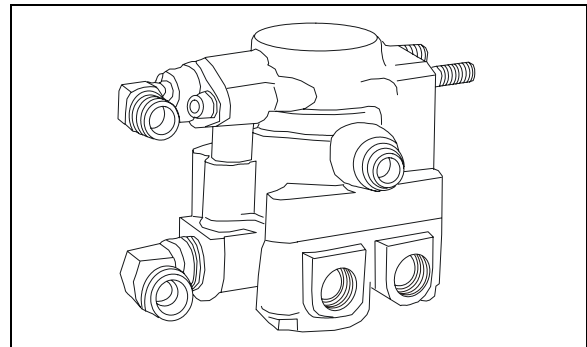

FIGURE 19: SR-7 12206

**20. PRESSURE PROTECTION VALVE (PR-4)**

Maintenance and repair information on the pressure protection valve is supplied in the applicable booklet annexed to this section under reference number SD-03-2010.

The air system includes two pressure protection valves (Fig. 20). One valve is installed on the manifold block, and insures at all times a minimum pressure of 70 psi (482 kPa) in the suspension air system in the event that a pressure drop occurs in either the suspension air system or accessory air system. This valve is located in the front service compartment beside the air filter.

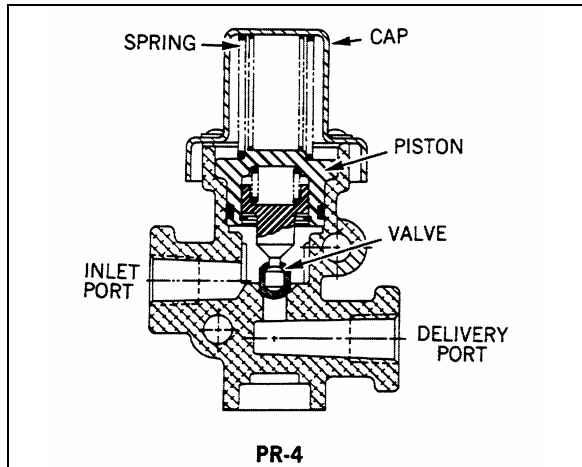

FIGURE 20: PR-4 12174

The other valve is installed on the accessory air tank, and insures a minimum pressure of 70 psi (482 kPa) in the accessory air system in the event that a pressure drop occurs in either the suspension air system or braking air system (refer to Fig. 1 & 2 for accessory air tank location).

### 21. LOW PRESSURE INDICATOR (LP-3)

Maintenance and repair information on the low pressure indicators is supplied in the applicable booklet annexed to this section under reference number SD-06-1600.

The air system includes two low pressure switches (Fig. 21), both located on the pneumatic accessory panel in the front service compartment. One serves for the parking brake signal, its pressure setting is  $66 \pm 6$  psi ( $455 \pm 40$  kPa). The remaining pressure switch monitors the parking brake telltale panel indicator; its pressure setting is 30 psi (205 kPa).

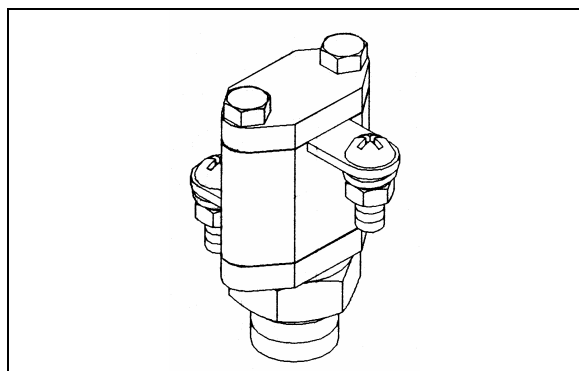

FIGURE 21: LP-3 12214

### 22. SHUTTLE-TYPE DOUBLE CHECK VALVE (DC-4)

Maintenance and repair information on the shuttle-type double check valve is supplied in the applicable booklet annexed to this section under reference number SD-03-2202.

The double check valve is located on the pneumatic accessory panel in the front service compartment. In the event of a pressure drop in either the primary or secondary system, this unit will protect the emergency /parking brake control valve and the intact portion of the air system from pressure loss.

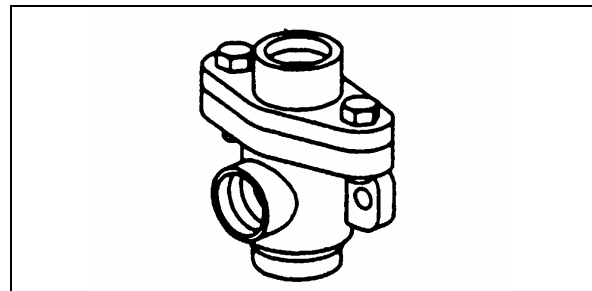

FIGURE 22: DC-4 12134

### 23. EMERGENCY DOOR OPENING VALVES

Two emergency door opening three-way valves are installed on coaches. One is in the front service compartment, readily accessible. The other one is on the R.H. side lateral console, close to the entrance door. When used, the valve releases pressure in the door locking cylinder, thus allowing the door to be manually opened.

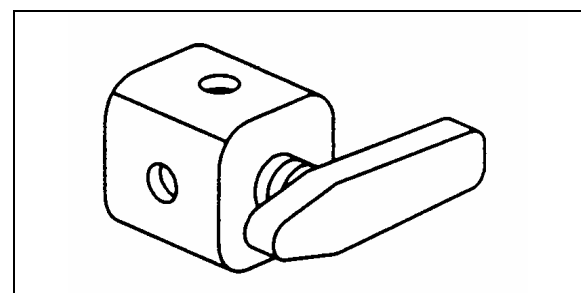

FIGURE 23: THREE-WAY VALVE 12186

### 24. AIR HORN VALVE

The air horn valve is located in the L.H. front service compartment. The air horn button is on the center of the steering wheel. Refer to section 23 "ACCESSORIES" for more information.

### 25. AIR SYSTEM TROUBLESHOOTING

The following list has been designed to help in troubleshooting some of the most common problems in the air system and main causes. For air brakes troubleshooting, refer to “*Air Brakes Troubleshooting*” in this section. For more troubleshooting information, refer to the manufacturer's brochures annexed to this section.

Air pressure doesn't rise to, or doesn't maintain, a normal setting:

- Defective air gauge (registering incorrectly).
- Excessive leaking in air system.
- Reservoir drain cock open.
- Governor poorly adjusted or defective.
- Defective compressor.
- Worn compressor or excessive wear on piston and/or ring.
- Air pressure rises to normal setting too slowly.

Excessive leaking in air system:

- Clogged engine air cleaner.
- Worn compressor or excessive wear on piston and/or ring.
- Engine speed too low.

Air pressure rises above a normal setting:

- Defective air gauge (registering incorrectly).
- Governor poorly adjusted or defective.
- Restriction in line between governor and compressor unloading mechanism.

Air pressure drops quickly when engine is stopped:

- Leaks in compressor discharge valve.
- Leaks in governor.
- Leaks in air lines.
- Leaks in air system valves.

### 26. BRAKE OPERATION

The vehicle braking system uses both service and parking air-operated brakes. The air system is divided into two independent circuits to isolate the front axle brakes and the rear axle brakes (drive and tag), thus providing safe brake

operation in the event that one circuit of the system fails. The primary circuit is connected to the drive and tag axle brakes, while the secondary circuit is connected to the front axle brakes. The tag axle service brakes operate only when the axle is in the normal driving (loaded) position. The spring-type emergency brakes are mounted on the drive and tag axles, and will apply automatically if primary system pressure falls below 40 psi (276 kPa).

Furthermore, brake application or release, which is speed up by a pneumatic relay valve (R-12), will start with the rear axles and be followed by the front axle, thus providing uniform braking on a slippery surface. The vehicle is also equipped with an Anti-lock Brake System (ABS), detailed later in this section.

Brake and air system maintenance consists of periodic inspections. Check all parts for damage and brake adjustment (refer to subsequent headings in this section for more details). Ensure all fasteners are tight (refer to “*Specifications*” for recommended tightening torques).

### 27. AIR BRAKES

#### 27.1 DISC BRAKES

*Knorr-Bremse SB7000* disc brakes are used on all axles. The front and drive axle discs are actuated by 24 square inch effective area air brake chambers, while on tag axle, the brake chambers have a 16 square inch effective area for service brake and a 16 square inch effective area for emergency/parking brakes. The *Knorr-Bremse SB7000* brakes are supplied with automatic clearance (slack) adjusters as standard equipment for easier adjustment. For more information on disc brake components and maintenance, refer to the manufacturer's brochure at the end of this section.

##### 27.1.1 Disc Brake Pads

Brake pads have to be checked on a regular basis depending on the vehicle operation. The remaining thickness of the pads should never be less than 3/32 in (2 mm). To check pad condition without removing the wheel, verify the position of guide bushing (6) relatively to guide sleeve (4) (see Fig. 24). When guide sleeve is in alignment with guide bushing, brake pad thickness has to be checked more precisely with the wheel removed. When replacing brake pads, all four pads on an axle have to be changed at the same time. There is no inner or outer pad,



## Section 12: BRAKE AND AIR SYSTEM

since all pads are the same. Once removed, worn pads should be replaced in their original position.

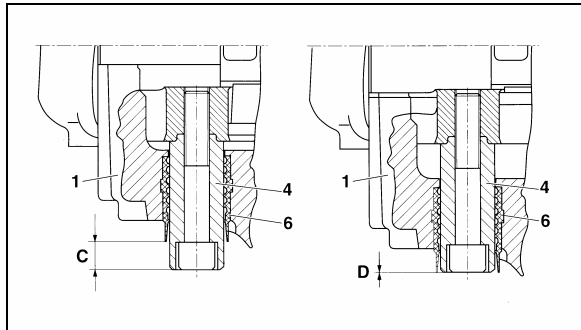

FIGURE 24: BRAKE PAD CHECK

12117

### 27.1.2 Caliper Maintenance

Use the following procedure for brake calipers servicing. The procedure must be followed in proper sequence to ensure that only needed repairs or replacements are performed on calipers. Problems such as hot brakes or cracked rotors may be effects of sticking calipers, too-small clearance between rotor and pad or possible trapped air pressure in the brake chamber. If any of these symptoms occur, perform this procedure before replacing the rotor to ensure the cause of the problem is properly solved.

#### 1. Check for presence of residual pressure:

To check if there is any residual air pressure in the brake chamber, make four or five brake applications, then try to turn the wheel manually, if the wheel does not turn, use a wrench to crack the air line and listen for trapped air in the brake chamber then try to turn the wheel manually again. If you find trapped air in the brake booster, ensure that all pneumatic components in the braking system are functioning properly.

#### **NOTE**

*A residual pressure of 2-3 PSI in the system is sufficient to prevent the brakes from releasing. Also the stop light switch can operate with as little as 1 PSI, therefore an illuminated brake light does not mean brakes are dragging.*

#### 2. Pad to rotor clearance inspection:

Remove clip and washer (26 & 45, Fig. 25), push down retainer bar (11), pull out pin (44) and remove retainer bar. Push caliper toward actuator (center of vehicle) for maximum clearance.

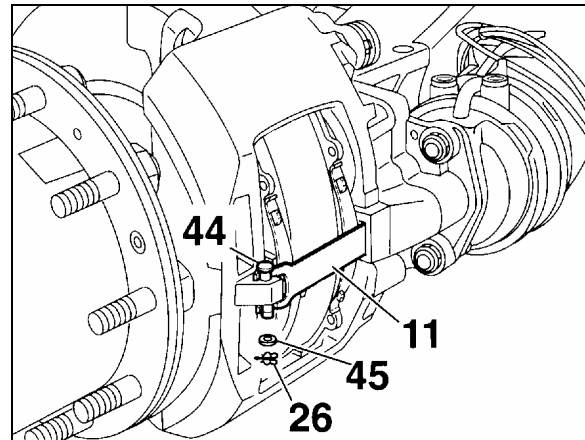

FIGURE 25: CLEARANCE INSPECTION

12119

#### 3. Measure pad to rotor clearance:

Place a long feeler gauge (long enough to measure across entire tappet surface) between the tappet and the backing plate of the pad, measure clearance at both tappets. Clearance should range between 0.020 and 0.035 inch (0.5 mm and 0.9 mm), with a maximum difference between tappet measurements on same brake of 0.008 inch (0.2 mm).

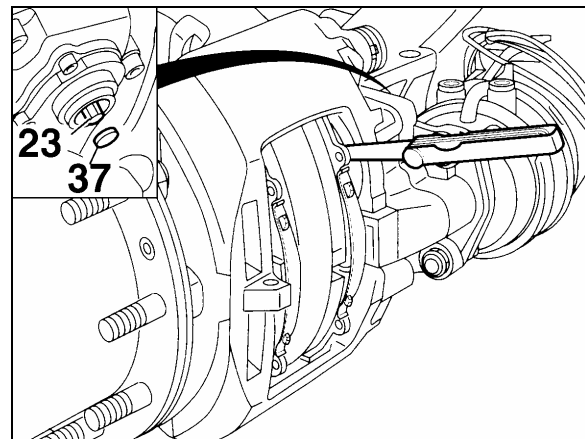

FIGURE 26: RUNNING CLEARANCE

12116

#### 4. Checking the adjuster

#### **WARNING**

**Use only a standard box wrench on the adjuster hexagonal pinion. Do not overtorque the pinion as overtightening will damage the pinion.**

- Remove cap (37, Fig. 26).
- Using a box wrench (8 mm), turn the adjuster pinion (23, Fig. 27) counterclockwise about 2 - 3 clicks to increase running clearance. By operating the braking system



about 5 - 10 times (30 PSI or 2 bar), the wrench should turn clockwise in small increments if the adjuster is functioning correctly (Figs. 27 and 28).

**NOTE**

*With increasing number of applications, the incremental adjustment will decrease.*

- c) In case of malfunction, i. e. the pinion or box wrench:
  - i) Does not turn.
  - ii) Turns only with the first application.
  - iii) Turns forwards then backwards with every application.

In any of the above cases, the automatic adjuster has failed and the caliper must be replaced. In such cases the brakes can be adjusted manually to run a short distance.

- d) Take the box wrench off. Replace the cap and check for proper sealing.

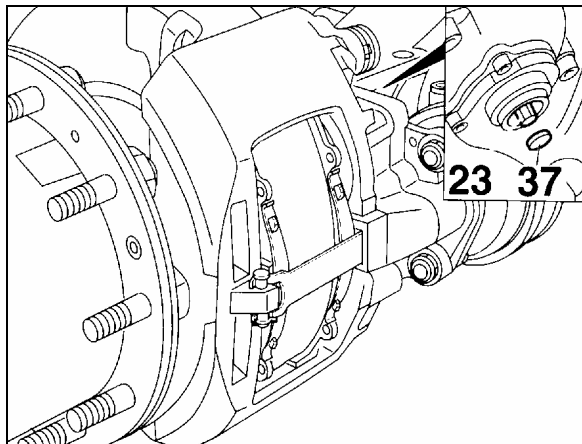

FIGURE 27: ADJUSTER PINION 12120

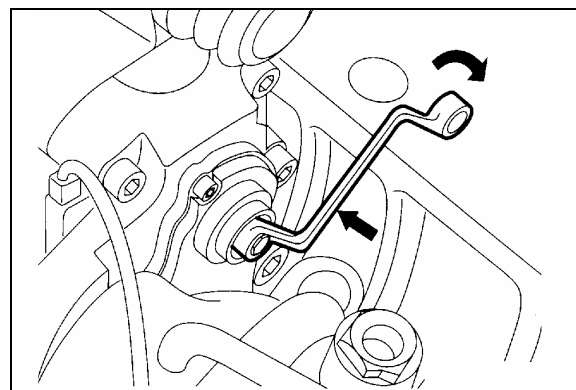

FIGURE 28: BOX WRENCH ON ADJUSTER PINION 12118

### 27.1.3 Roadside Inspection for Knorr/Bendix Air Disc Brakes

The coach is equipped with air disc brakes and therefore, cannot be inspected using the requirements for chamber stroke or visible lining clearance or lining thickness as specified for drum brakes. The roadside inspector should use the following instructions to determine that the air disc brakes are within proper adjustment and have sufficient pad wear thickness.

The Knorr/Bendix air disc brake is designed to move freely, with minimal force, in the axial direction on the two sliding pins as identified in figure 29. The movement in the axial direction should not exceed 2 mm (5/64").

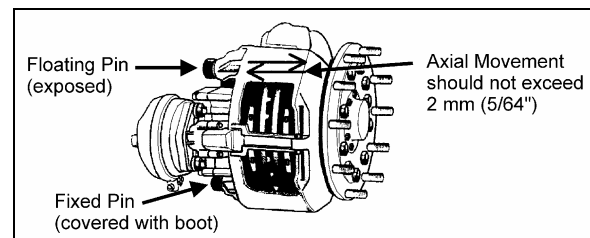

FIGURE 29: CALIPER AXIAL MOVEMENT 12132

The pad thickness can be seen but would require removal of the tire and rim. An indicator of the pad wear condition is available by inspecting the floating pin location in relation to the rubber bushing as shown in figure 30. When pads are in new thickness condition, the pin will be exposed (C) 19 mm (3/4"). When the pads are worn to replacement conditions, the pin will be nearly flush to the bushing (D) or within 1 mm (3/64") of the edge of the rubber bushing.

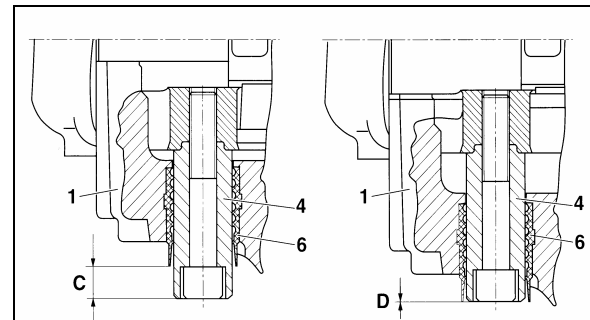

FIGURE 30: BRAKE PAD CHECK 12117

### 27.1.4 Pad Removal

Turn adjuster pinion (23) counterclockwise to increase pad to rotor clearance (a clicking noise will be heard). Push caliper toward actuator and remove pads (12).

## Section 12: BRAKE AND AIR SYSTEM



**Do not apply brakes while pads are removed as this could cause over stroke damage to the adjusting mechanism.**

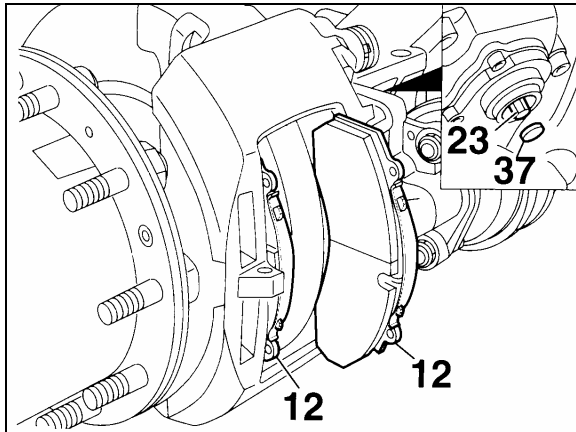

FIGURE 31: PAD REMOVAL

12111

### 27.1.5 Checking Pad Wear

Minimum friction material thickness is 2 mm (A, Fig. 32)

New friction material has a thickness of 21 mm (B, Fig. 32)

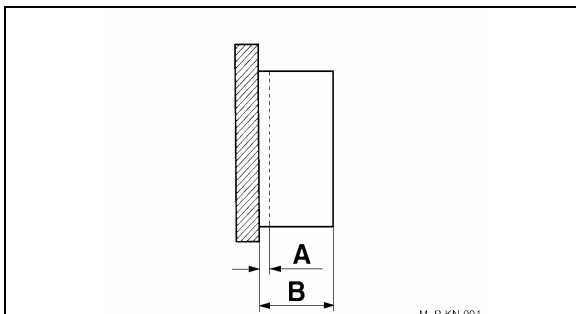

FIGURE 32: PAD WEAR

12112

### 27.1.6 Important Pad and Rotor Measurements

A = Rotor thickness (new): 45 mm;

B = Rotor thickness (worn): 37 mm, requires replacement;

C = Overall thickness of pad (new): 30 mm;

D = Backplate: 9 mm;

E = Minimum thickness of pad material: 2 mm;

F = Minimum allowed thickness of overall backplate and friction material: 11 mm.  
**Replacement necessary.**

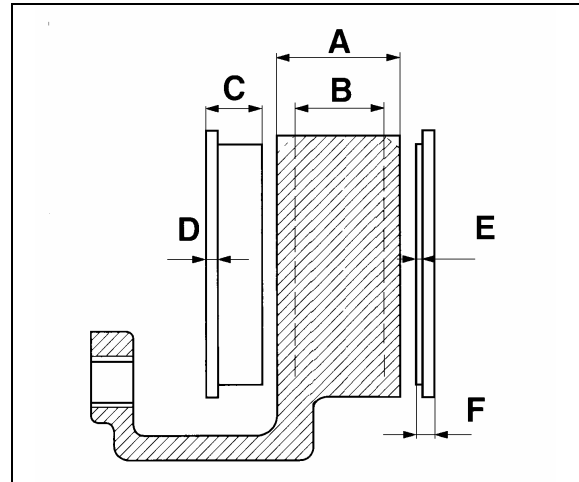

FIGURE 33: ROTOR AND PAD WEAR LIMITS

12113

### 27.1.7 Checking Caliper Guidance and Seal Condition

Perform sliding test. You must be able to slide the caliper easily at any time. Sliding test should be performed at least every three months or more often depending on the type of operation.

Sliding Test (Refer to Fig. 34):

- Using hand pressure only, the caliper (1) must slide freely with its guide pin arrangements (4-7) across a distance of 1 3/16 inch (30 mm) when the pads are removed. The sleeve (5) is sealed using the boot (9) and the cap (10).
- The rubber components (9 and 10) should show no damage. The positioning must be checked. If necessary the caliper has to be repaired using the guide kit (part #611168) or with the seal and guide kit (part #611199). When repairing a caliper with the above kits, make sure all parts in the kit are used. Use special green grease (Prévost #683344) to reassemble the slide pin into the bushing, white or yellow grease (Prévost #683345) may be used for all other lubrication needs.
- Depending on caliper manufacturing date, black paint may be present on the unsealed pin (short pin). Paint on the slide pin can prevent the caliper from sliding properly especially when the pad starts to wear. If paint is present on the pin, separate the pin from the bushing, clean and reinstall the pin according to procedure.

**NOTE**

Do not attempt to use thinner or alcohol to clean the pin without removing it as it may damage the rubber bushing.

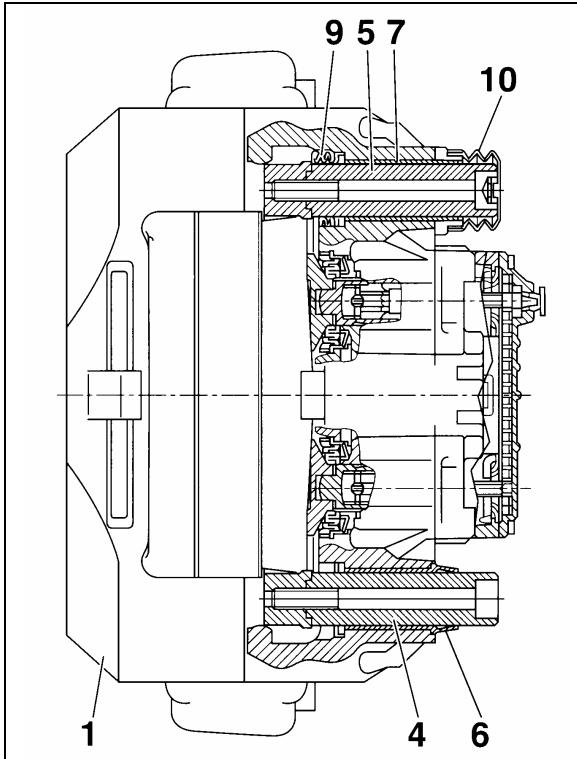

FIGURE 34: CALIPER GUIDANCE 12114

27.1.8 Checking the Tappet Boots

- a) The rubber boots (13, Fig. 35) should show no damage, check the attachment.

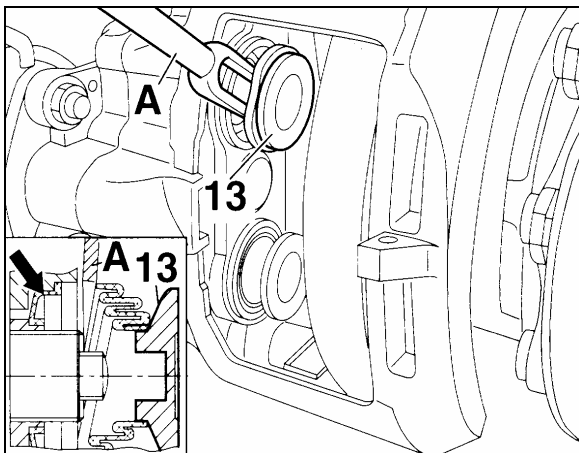

FIGURE 35: RUBBER BOOTS 12115

**CAUTION**

Any ingress of water and dirt will lead to corrosion and may affect the function of the actuation mechanism and adjuster unit.

- b) If boots are damaged but show no corrosion, the boots and tappets should be replaced (Prévost #611177).

27.1.9 Pad Installation

Turn adjuster pinion (23, Fig. 36) counterclockwise until tappets are fully retracted and clean pad seat area. Slide caliper to full outboard position and install outside pad. Slide caliper to full inboard position and install inside pad.

**WARNING**

It is recommended to change all pads on an axle at the same time.

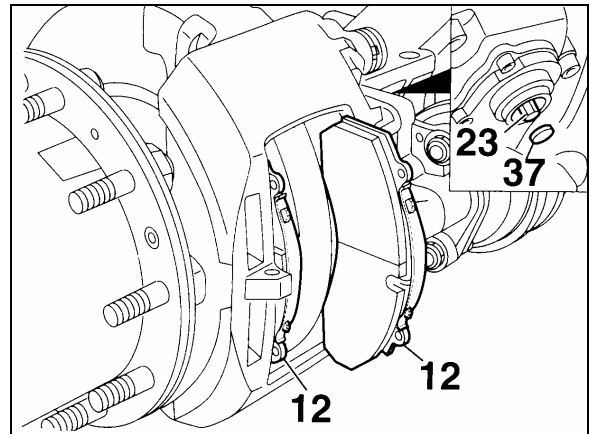

FIGURE 36: PAD INSTALLATION 12111

27.1.10 Adjusting the Running Clearance

- a) Insert a feeler gauge 0.028 inch (0.7 mm thickness) between tappet and pad backplate (Fig. 37). Turn adjuster pinion clockwise until 0.028 inch (0.7 mm) clearance is achieved. Replace cap (37) (Prévost # 641313).
- b) To ensure a constant running clearance between the rotor and pads, the brake is equipped with an automatic adjuster unit. When the pads and rotor wear, the running clearance between the pads and rotor increases. The adjuster (23, Fig. 37) and turning device turn the threaded tubes by the amount necessary to compensate the wear.

Total running clearance should be between 0.020 and 0.035 inch (0.5 and 0.9 mm). Smaller clearances may lead to overheating problems.

## Section 12: BRAKE AND AIR SYSTEM

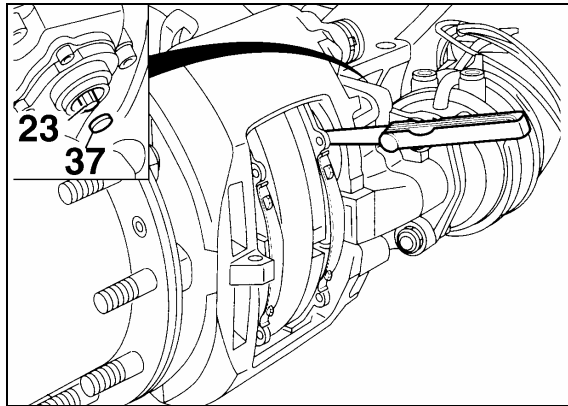

FIGURE 37: RUNNING CLEARANCE

12116

### 27.1.11 Brake Tools

Four brake tools are available from Prévost to facilitate disc brake maintenance:

- #641321, Tappet with boot (item 13).
- #641322, Caliper inner boot (item 9).
- #641323, Caliper bushing (item 7).
- #641435, Fork for boot tappet (item 13).

### Maintenance tip

Using the following procedure, pad wear can be determined without removing the wheel.

### 27.1.12 Checking Brake Pads

Brake pads have to be checked on a regular basis depending on the vehicle operation. The remaining thickness of the pads should never be less than 3/32 inch (2 mm). To check pad condition without removing the wheel, verify the position of guide bushing (6) relatively to guide sleeve (4) (Fig. 38). When guide sleeve is in alignment with guide bushing, brake pad thickness must be checked more precisely with wheel removed. When replacing the brake pads, all four pads on an axle have to be changed at the same time. There is no inner or outer pad, since all pads are the same. Worn pads should be replaced in the same position.

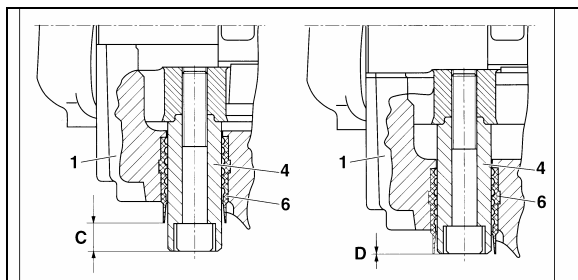

FIGURE 38: BRAKE PAD CHECK

12117

### 27.1.13 Torque specifications

For proper caliper maintenance, refer to the following figures.

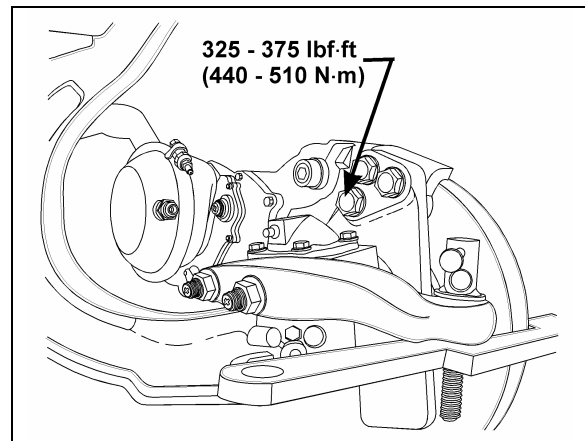

FIGURE 39: TORQUE SPECIFICATION

12145

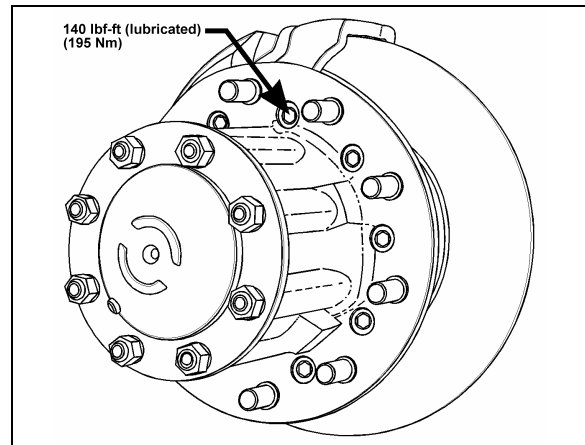

FIGURE 40: TORQUE SPECIFICATION

12149

## 28. SAFE SERVICE PROCEDURES

Most recently manufactured brake linings no longer contain asbestos fibers. Instead of asbestos, these linings contain a variety of ingredients, including glass fibers, mineral wool, aramid fibers, ceramic fibers, and carbon fibers. At present, OSHA (Occupational Safety and Health Administration) does not specifically regulate these non-asbestos fibers, except as nuisance dust. Medical experts do not agree about the potential long-term risks from working with and inhaling non-asbestos fibers. Nonetheless some experts think that long-term exposure to some non-asbestos fibers could cause diseases of the lung, including pneumoconiosis, fibrosis, and cancer. Therefore, lining suppliers recommend that workers use caution to avoid creating and breathing dust when working on brakes that contain non-asbestos fibers.

**⚠ WARNING ⚠**

Whenever possible, work on brakes in a separate area away from other operations.

Always wear a respirator approved by NIOSH (National Institute of Occupational Safety and Health) or MSHA (Mine Safety and Health Administration) during all brake service procedures. Wear the respirator from removal of the wheels through assembly.

NEVER use compressed air or dry brushing to clean brake parts or assemblies. OSHA recommends that you use cylinders that enclose the brake. These cylinders have vacuums with high efficiency (HEPA (Health and Environment Protection Agency)) filters and workmans' arm sleeves. But, if such equipment is not available, carefully clean parts and assemblies in the open air.

Clean brake parts and assemblies in the open air. During disassembly, carefully place all parts on the floor to avoid getting dust into the air. Use an industrial vacuum cleaner with a HEPA filter system to clean dust from the brake drums, backing plates and other brake parts. After using the vacuum, remove any remaining dust with a rag soaked in water and wrung until nearly dry.

If you must grind or machine brake linings, take additional precautions because contact with fiber dust is higher during these operations. In addition to wearing an approved respirator, do such work in an area with exhaust ventilation.

When cleaning the work area, NEVER use compressed air or dry sweeping to clean the work area. Use an industrial vacuum with a HEPA filter and rags soaked in water and wrung until nearly dry. Dispose of used rags with care to avoid getting dust into the air. Use an approved respirator when emptying vacuum cleaners and handling used rags.

Wash your hands before eating, drinking or smoking. Do not wear your work clothes home. Vacuum your work clothes after use and then launder them separately, without shaking, to prevent fiber dust from getting into the air.

Material safety data sheets on this product, as required by OSHA, are available from Rockwell and Knorr-Bremse.

**29. AIR BRAKE TROUBLESHOOTING**

The following tests and check lists have been designed to identify the cause(s) of a sluggish performance and/or leaks in the system. These tests require very little time to perform, and give you a general idea of the system condition. Each test is provided with a corresponding check list which will guide you to the most common causes of problems.

Before performing any test, check all air lines for kinks or dents, and hoses for signs of wear, drying out or overheating.

**⚠ WARNING ⚠**

When working on or around brake system and its related components, the following precautions should be observed:

Always block vehicle wheels. Stop engine when working under a vehicle. Keep hands away from chamber push rods and slack adjusters as they may apply when system pressure drops.

Never connect or disconnect a hose or line containing air pressure. It may whip as air escapes. Never remove a component or pipe plug unless you are sure all system pressure has been depleted.

Never exceed recommended air pressure and always wear safety glasses when working with air pressure. Never look into air jets or direct them at anyone.

Never attempt to disassemble a component until you have read and understood the recommended procedures. Some components contain powerful springs and injury can result if not properly disassembled. Use only proper tools and observe all precautions pertaining to the use of those tools.

Always clean connecting piping and/or fittings, and coat pipe threads with Teflon pipe sealant before installing any air brake system component.

Section 12: BRAKE AND AIR SYSTEM

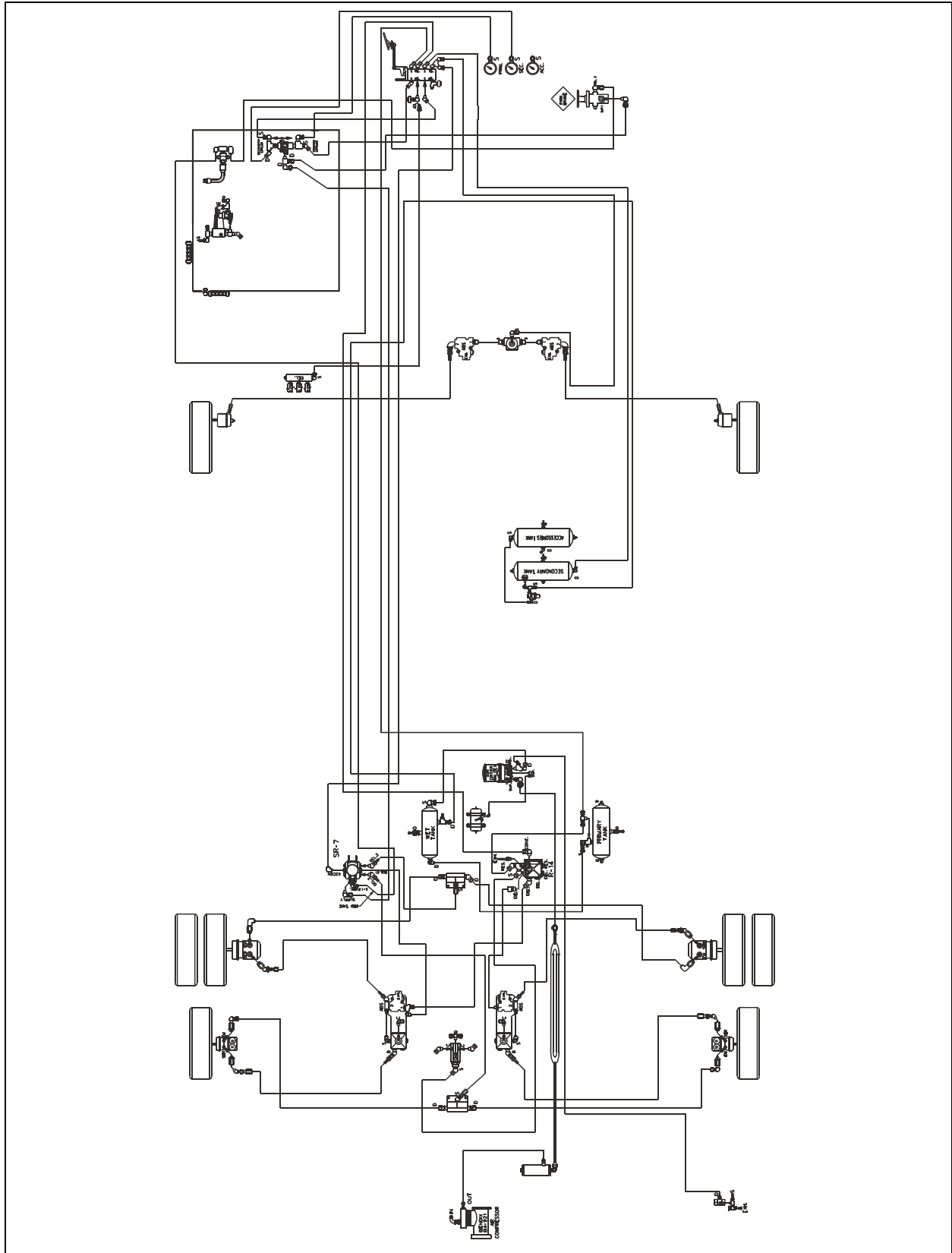

FIGURE 41: AIR-OPERATED BRAKING SYSTEM FOR X3 COACHES EQUIPPED WITH I-BEAM AXLE FRONT SUSPENSION<sup>12215</sup>

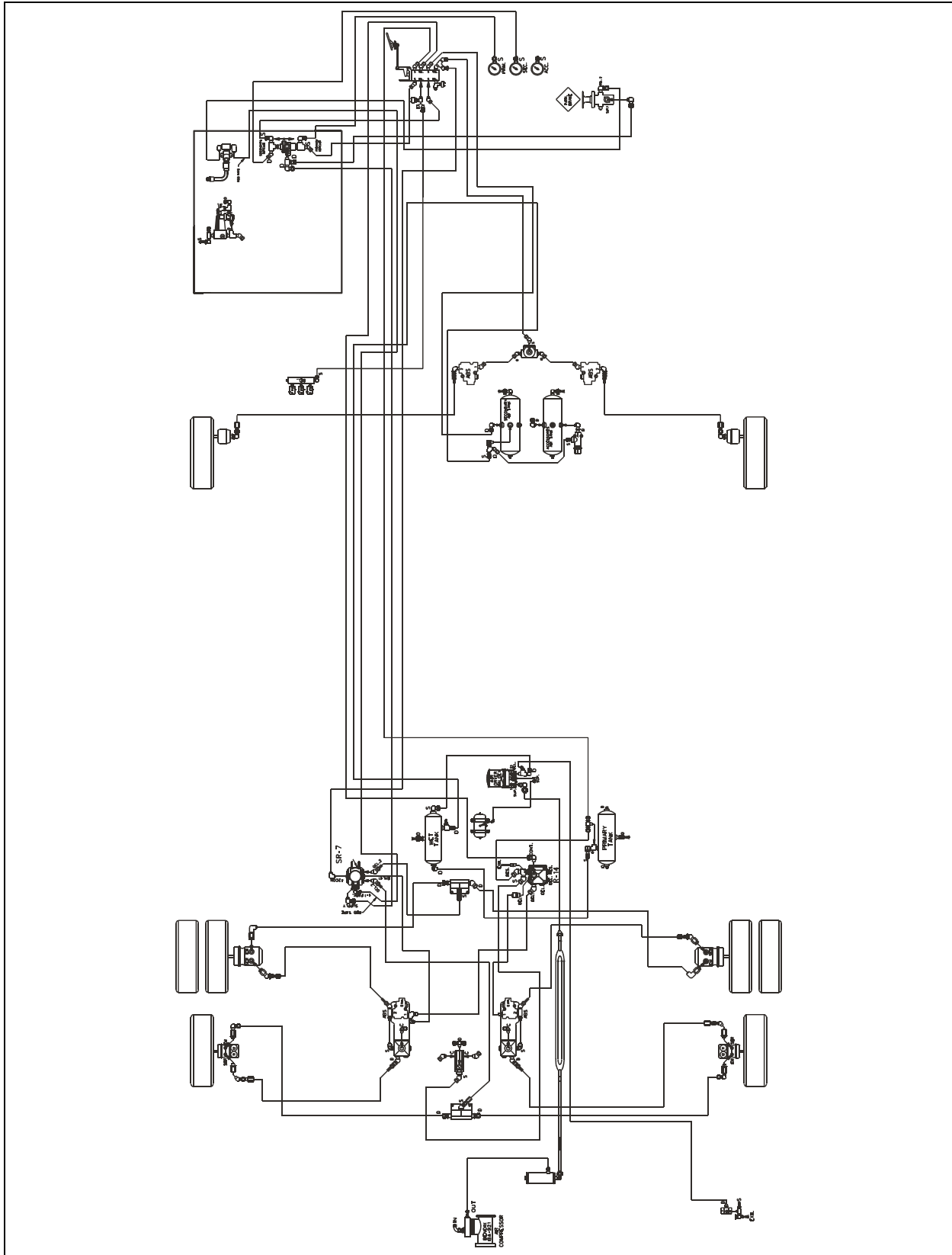

FIGURE 42: AIR-OPERATED BRAKING SYSTEM FOR X3 COACHES EQUIPPED WITH INDEPENDENT FRONT SUSPENSION <sup>12216</sup>

## Section 12: BRAKE AND AIR SYSTEM

---

### **Pressure Build-Up / Low Pressure Warning / Cutoff Point / Air Filter/Dryer Built-in Governor Cutout**

CONDITION: Vehicle leveled, parking brake applied.

1. Completely drain wet, primary and secondary air reservoirs only.
2. Start engine and run at fast idle. Low pressure warning lights should be "On".
3. Start checking pressure at 50 psi (344 kPa).
4. Low pressure warning lights and buzzer should go off at or above 60 psi (415 kPa).
5. At 85 psi (586 kPa), run engine at full rpm, then check that build up time to 100 psi (690 kPa) is 30 seconds or less.
6. Air filter/dryer built-in governor cut-out. Cuts out at the correct pressure of 123 psi  $\pm$ 3 (847 $\pm$ 21 kPa).
7. Air filter/dryer built-in governor cut-in. Cuts in around 110 psi (758 kPa).

For common corrections, refer to the following check list:

#### **High or Low Warning Cutoff Point**

- Perform a telltale light and gauge test. Replace entire cluster if found defective.

#### **High or Low Air Filter/Dryer Built-in Governor Cutout Point**

- Perform a telltale light and gauge test. Replace entire cluster if found defective.

OR

- Repair or replace air filter/dryer as necessary after checking that compressor unloader mechanism operates correctly.

#### **More than 30 seconds to build-up pressure from 85 to 100 psi (585 - 690 kPa) at full engine RPM**

- Perform a telltale light and gauge test. Replace entire cluster if found defective.
- Check compressor strainer or inlet line. If restricted, clean or replace element or faulty line.
- Check compressor head or discharge line for carbonization or restriction. Clean or replace as necessary.

- If discharge valves leak, pull head and correct or replace cylinder head.
- If drive is slipping, replace gear.
- If inlet valves are stuck, open or leaking severely, replace unloader kit, inlet valves and/or seats as necessary.
- If drain cock is found open, close it.
- Listen for air leaks and repair.
- Redo list to check all items repaired or replaced.

#### **Air Supply Reservoir Leakage**

CONDITION: Full pressure, engine stopped, parking brake applied

1. Allow at least 1 minute for pressure to stabilize.
2. Stop engine, then check air pressure gauge for 2 minutes. Note any pressure drop.
3. Pressure should not drop by more than 3 psi (20 kPa) per minute.

For common corrections, refer to the following check list:

Excessive air loss:

- With the primary air system at normal operating pressure (95 - 125 psi (655 - 860 kPa)), coat all air line connections and pneumatic components with a water and soap solution. Bubbles will indicate an air leak, and none should be permissible. Repair or replace defective parts.
- Listen for leaks and correct as required.
- Redo test to check all items repaired or replaced.

#### **Brake System Air Leakage**

CONDITION: Full pressure, engine stopped, parking brake released.

1. Apply service (foot) brakes, allow at least 1 minute for pressure to stabilize.
2. Hold down foot valve for 2 minutes while observing air pressure gauge on the dashboard.
3. Pressure drop should not be more than 4 psi (27 kPa) per minute.

For common corrections, refer to the following check list.



**Excessive leakage on brake service side:**

- With the primary air system at normal operating pressure (95 - 125 psi (655 - 860 kPa)) and foot brake applied, coat all air line connections and brake pneumatic components with a water and soap solution. Bubbles will indicate an air leak, and none should be permissible. Repair or replace defective parts.
- Listen for leaks and correct as required.
- Redo test to check all items repaired or replaced.

**IMPORTANT NOTE**

To maintain your vehicle's air disc brakes at their original performance standard, we strongly recommend use of only genuine, approved service replacement parts on Bendix and Knorr-Bremse air disc brake systems. If non-approved friction materials or replacement components are used, neither Prévost Car nor Bendix Spicer Foundation Brake LLC will accept any air disc brake-related warranty returns or claims.

For more information on this policy, refer to Bendix-Prévost product notification annexed at the end of Section 12 of Maintenance Manual.

**30. BRAKE AIR CHAMBER**

If this vehicle is equipped with *Knorr-Bremse SB7000* disc brakes on all axles, it also uses "Knorr-Bremse" brake chambers. The tag and drive axle chambers consist of two separate air chambers, each having its own diaphragm and push rod. They are used as a service brake chamber, an emergency brake in case of air pressure loss and a spring-applied parking brake. Refer to figures 43 and 44.

The front axle brake air chambers are used only for service brake duty (Fig. 43).

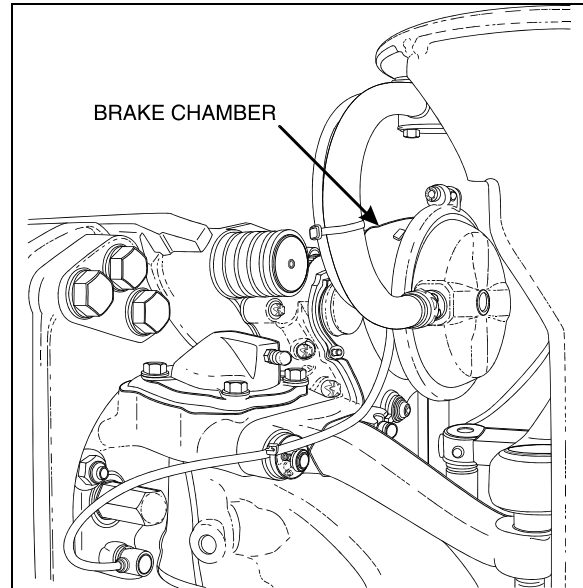

FIGURE 43: FRONT AXLE BRAKE AIR CHAMBER 12158

30.1 MAINTENANCE

**Every 6,250 Miles (10 000 km) or twice a year, whichever comes first depending on type of operation:**

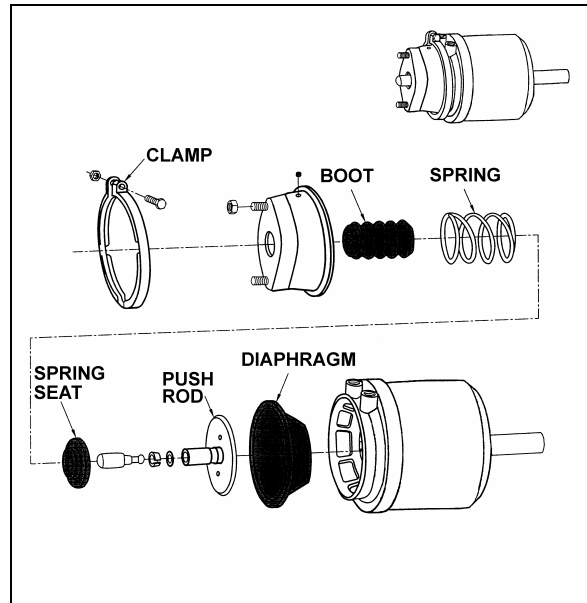

FIGURE 44: TAG AXLE BRAKE AIR CHAMBER 12126

Check all hoses and lines. They should be secure and in good condition.

**Every 100,000 Miles (160 000 km) or once a year, whichever comes first depending on type of operation:**

1. Disassemble and clean all parts.

## Section 12: BRAKE AND AIR SYSTEM

2. Install new diaphragm or any other part if worn or deteriorated.

### NOTE

*When the diaphragm, spring, or both are replaced, they should be replaced in the corresponding chamber on the same axle.*

3. Perform an airtightness test:
  - a) Make and hold a full brake application.
  - b) Coat clamping ring(s) with a soapy solution. If leakage is detected, tighten clamping ring only enough to stop leakage. **Do not overtighten** as this can distort sealing surface or clamping ring. Coat area around push rod hole (loosen boot if necessary). No leakage is permitted. If leakage is detected, the diaphragm must be replaced.

### 30.2 EMERGENCY/PARKING BRAKE MANUAL RELEASE

#### WARNING

**Never stand in the axis line of the spring brake chambers, especially when caging the spring.**

#### Drive Axle

1. Block the wheels to prevent the vehicle from moving.
2. Remove the release stud tool from its storage place on drive axle brake air chamber.
3. Remove the access plug from the end of the spring chamber and then insert the release stud through the opening. Turn the release stud ¼ turn (clockwise) to anchor it into the spring plate. Install the flat washer and nut, then turn the nut clockwise to cage the spring. Repeat on the opposite side.

#### WARNING

**Make sure the release stud is properly anchored in spring plate receptacle prior to caging the spring.**

4. To manually reset the emergency/parking brake, turn the nut counterclockwise. Reinstall access plugs on the spring chambers, and release stud tools in their storage places.

#### Tag Axle

1. Block the wheels to prevent the vehicle from moving.
2. Turn the release bolt counterclockwise to cage the power spring (approx. 2.5 inches (6 cm)). Repeat on the opposite side.
3. To manually reset the emergency/parking brake, turn the bolt clockwise.

### 30.3 BRAKE CHAMBER REMOVAL

#### WARNING

**To prevent personal injuries, brakes should be inoperative prior to working on any of their components.**

**To prevent personal injuries, brake chambers should be made inoperative by releasing spring tension prior to disposal.**

1. Block the wheels to prevent the vehicle from moving.
2. Safely support vehicle at the recommended body jacking points.
3. To gain access to a given brake air chamber, the corresponding wheel can be removed (refer to Section 13: "Wheels, Hubs and Tires").
4. Exhaust compressed air from system by opening the drain valve of each reservoir.
5. For the drive and tag axles brake chambers, manually release spring brakes (refer to "Emergency/Parking Brake, Manual Release" procedure in this section).
6. Disconnect air line(s) from brake chamber.
7. Remove the cotter pin connecting brake chamber and slack adjuster (drive axle).
8. Unbolt and remove the brake chamber from vehicle.

### 30.4 BRAKE CHAMBER INSTALLATION

Reverse removal procedure and then check brake adjustment.

#### CAUTION

**Always clean air lines and fittings, and coat pipe threads with teflon pipe sealant before reconnecting air lines.**

30.5 BRAKE CHAMBER DISASSEMBLY

**⚠ WARNING ⚠**

**Spring brake chambers, on drive and tag axles contain an extremely high compressive force spring, which can possibly cause serious injury if special precautions are not taken when working around this area.**

**To avoid such injury, the following recommendations must be applied:**

- **Prévost recommends the installation of a new spring brake chamber if it is found to be defective.**
- **Spring brake chamber maintenance and/or repair must be performed by trained and qualified personnel only.**
- **Before manually releasing spring brakes, visually check spring brake for cracks and/or corrosion.**
- **On “MGM” brake chambers (drive axle), make sure the release stud is properly anchored in spring plate receptacle prior to caging the spring.**
- **Never stand in the axis line of the spring brake chambers, especially when caging the spring.**

**⚠ WARNING ⚠**

**To prevent personal injuries, brakes should be inoperative prior to working on any of their components.**

1. Block the wheels to prevent the vehicle from moving.
2. Safely support vehicle at the recommended body jacking points.

**NOTE**

*To gain access to a given brake air chamber, the corresponding wheel can be removed (refer to Section 13: "Wheels, Hubs and Tires").*

3. Exhaust compressed air from air system by opening the drain valve of each reservoir.
4. For the drive and tag axles brake chambers, manually release spring brakes (refer to "Emergency/Parking Brake Manual Release" procedure in this section).

5. Remove clamp ring, remove and discard the existing diaphragm. Install the new diaphragm squarely on body.
6. Reverse the procedure for assembly. Tap clamp ring to ensure proper seating. Check for proper operation before placing vehicle in service.

**31. ANTI-LOCK BRAKING SYSTEM (ABS)**

This device has been designed to ensure stability and permit steering control of vehicle during hard braking, and to minimize its stopping distance whatever the road conditions are. On slippery roads and generally in emergency situations, over-braking frequently induces wheel lock. The anti-lock braking system provides maximum braking performance while maintaining adequate steering control on slippery roads.

The ABS continuously monitors wheel behavior during braking. Sensors on each wheel of front and drive axles (tag axle is slave to drive axle) transmit data to a four channel electronic processor which senses when any wheel is about to lock. Modulator valves quickly adjust the brake pressure (up to 5 times per second) to prevent wheel locking. Each wheel is therefore controlled according to the grip available between its tire and the road.

With this device, the vehicle is brought to a halt in the shortest possible time, while remaining stable and under the driver's control.

Since the braking system has dual circuits, the ABS is also provided with a secondary system should a fault develop in the ABS. Anti-lock systems are a parallel system which does not hinder brake functioning in case of failure. Braking system functions in normal, non anti-lock controlled operation during ABS system failure.

The ABS system consists of two diagonally related circuits, only the half of the system which has sustained damage or other fault is switched off (i.e. wheels return to normal non-ABS braking). The other diagonal half remains under full ABS control.

**NOTE**

*ABS is active on service brake, transmission retarder, Jake brake, but is inactive on emergency/parking brake.*

## Section 12: BRAKE AND AIR SYSTEM

### NOTE

The ABS system is inoperative at speeds under 4 mph (6 Km/h). Illumination of ABS telltale indicator at these speeds is normal.

### CAUTION

Disconnect the ECU or pull the ABS fuse before towing vehicle.

### 31.1 TROUBLESHOOTING AND TESTING

For troubleshooting and testing of the vehicle's anti-lock braking system, refer to Meritor Wabco Maintenance Manual MM-0112: "Anti-Lock Braking System (ABS) for Trucks, Tractors and Buses", at the end of this section. Use dashboard Message Center Display (MCD) Diagnostic Mode for troubleshooting and repair.

### 31.2 ABS COMPONENTS

The main components of the ABS system are listed hereafter. Refer to each component for its specific function in the system and for proper maintenance.

#### 31.2.1 Electronic Control Unit (ECU)

This control unit is located in the front electrical compartment, (refer to figure 45 for location). According to the data transmitted by the sensors (number of pulses/sec is proportional to the speed of each wheel), the electronic control unit determines which wheel is accelerating or decelerating. It then establishes a reference speed (average speed) from each wheel data, and compares the speed of each wheel with this reference speed to determine which wheel is accelerating or decelerating.

As soon as wheel deceleration or wheel slip threshold values are exceeded, the electronic control unit signals a solenoid control valve to limit the excessive brake pressure produced by the driver in the appropriate brake chamber.

#### Maintenance

No specific maintenance is required. The ECU is not serviceable. When found to be defective, replace.

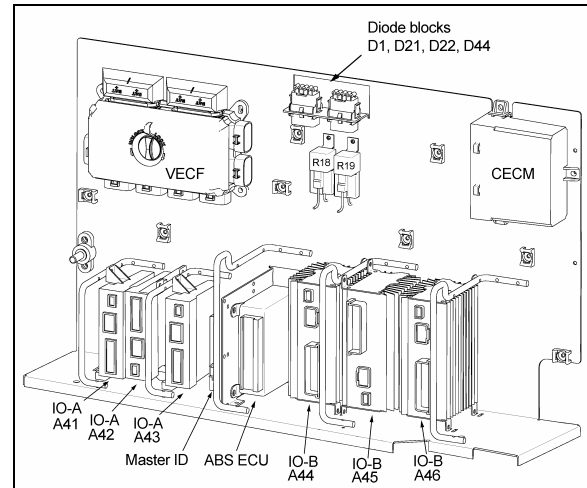

FIGURE 45: ABS ECU LOCATION

06617

### CAUTION

In order to protect the ABS electronic control unit from voltage surges, always disconnect before performing any welding procedure on vehicle.

#### 31.2.2 ABS Modulator Valve

This ABS system is equipped with four modulator valves, located between the brake chamber and the relay valve or quick release valve (Fig. 46). Note that there is only one solenoid valve controlling the drive and tag axle wheels on the same side (tag axle is slave to drive axle).

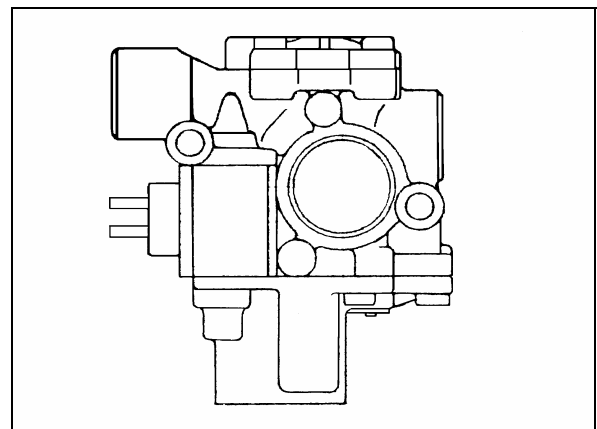

FIGURE 46: ABS MODULATOR VALVE

12084

This is an "On/Off" type valve, i.e., at brake application, the valve exhausts air from the brake chamber when the electronic unit senses that the corresponding wheel speed is decreasing in relation to the other wheels.

**Maintenance**

No specific maintenance is required for the solenoid control valve.

31.2.3 Sensors

The sensors are mounted on the front and drive axle wheel hubs (Fig. 47). The inductive sensors consist essentially of a permanent magnet with a round pole pin and a coil. The rotation of the toothed wheel alters the magnetic flux picked up by the coil, producing an alternating voltage, the frequency of which is proportional to wheel speed. When wheel speed decreases, magnetic flux decreases proportionately. Consequently, the electronic control unit will command the solenoid control valve to decrease the pressure at the corresponding brake chamber.

**Maintenance**

No specific maintenance is required for sensors, except if the sensors have to be removed for axle servicing. In such a case, sensors should be lubricated with special grease (Prévost #680460) before reinstallation. Refer to paragraph "Sensor Installation" for details.

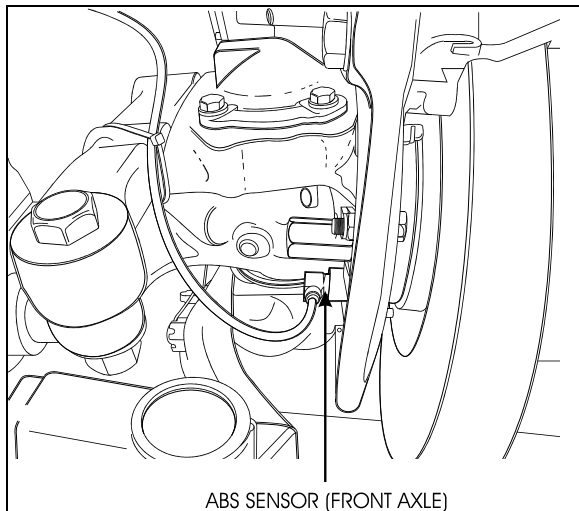

FIGURE 47: ABS SENSOR LOCATION

12153

**NOTE**

*The resistance value, when sensors are checked as a unit, must be equal to 1,75 k ohms. To check the sensors for proper output voltage after the sensors and toothed wheels have been assembled to the axle, connect a suitable AC voltmeter across the output terminals. With the hubs rotating at 30 rpm, the output voltages should read from 50 to 1999 mV to be acceptable.*

31.2.4 Sensor Installation

The following procedure deals with sensor installation on the axle wheel hubs. Read procedure carefully before reinstalling a sensor, as its installation must comply with operational tolerances and specifications.

1. Apply recommended lubricant (Prévost #680460) to spring clip and sensor.



**Use only this type of grease on the sensors.**

2. Insert spring clip in the holder on hub. Make sure the spring clip tabs are on the inboard side of the vehicle. Push in until the clip stops.
3. Push the sensor completely inside the spring clip until it is in contact with the tooth wheel. Ensure mounting is rigid, as it is an important criterion for adequate sensor operation.

**NOTE**

*This installation should be of the "press fit" type.*

31.2.5 Spring clip

The spring clip retains the sensor in its mounting bracket close to the toothed pulse wheel. The gap between the sensor end and teeth is set automatically by pushing the sensor in the clip hard up against the tooth wheel, and the latter knocks back the sensor to its adjusted position (Fig. 48).

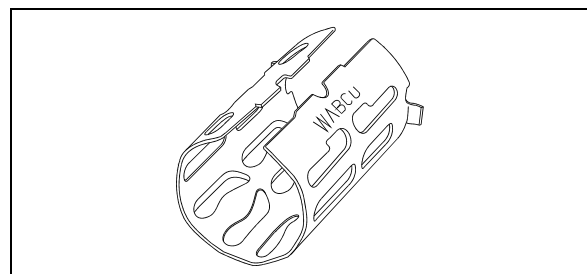

FIGURE 48: SPRING CLIP

12161

**Maintenance**

The spring clip requires no specific maintenance.

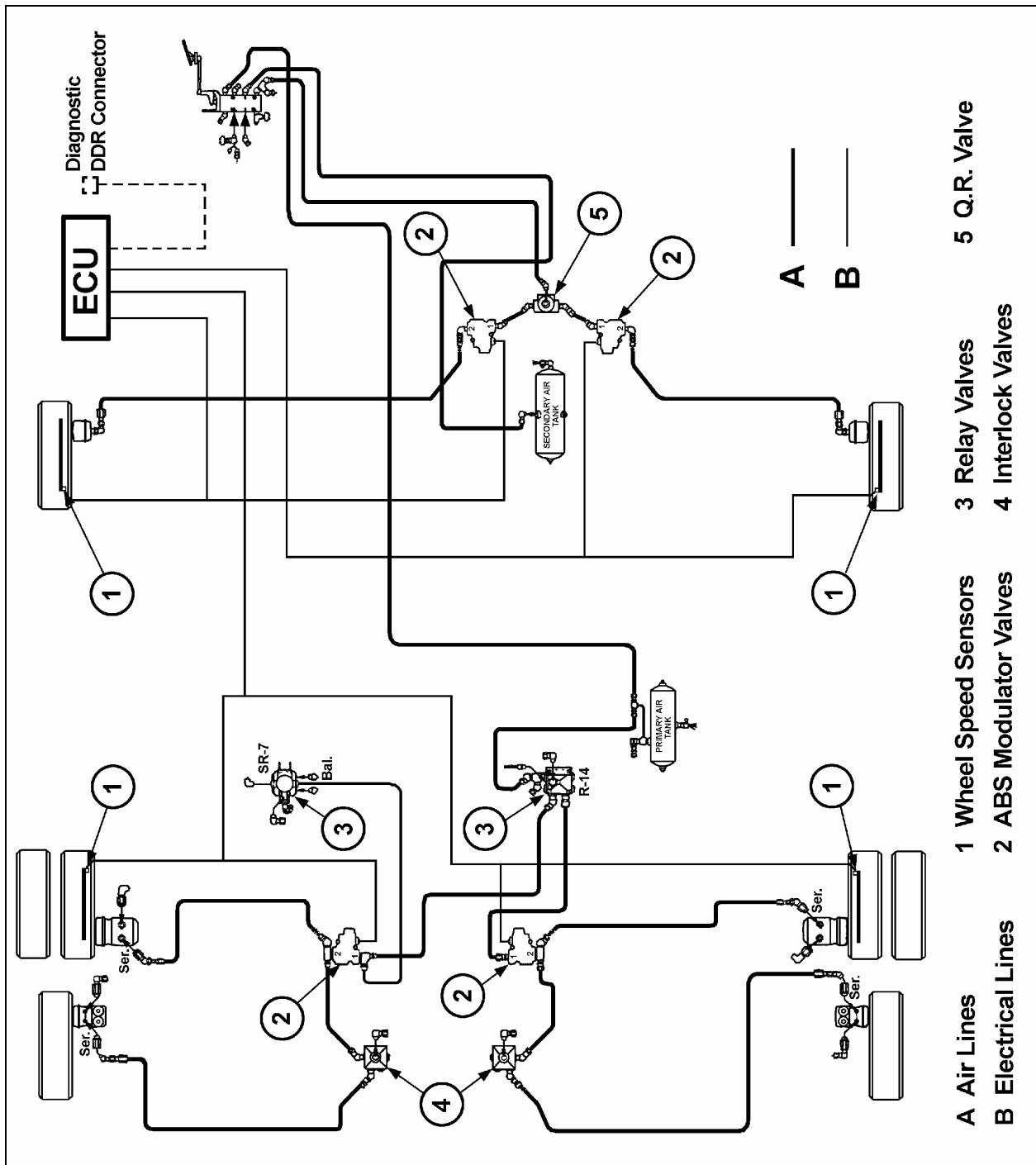

FIGURE 49: ABS 4S/4M CONFIGURATION

32. FITTING TIGHTENING TORQUES

**45° Flare and Inverted Flare:** Tighten assembly with a wrench until a solid feeling is encountered. From that point, tighten 1/6 turn (Fig. 50).

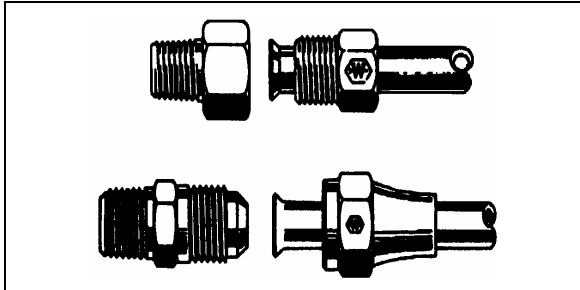

FIGURE 50: HOSE FITTINGS 12053

**Compression:** Tighten nut by hand (Fig. 51). From that point, tighten using a wrench the number of turns indicated in the chart hereafter.

Fitting size	Pipe diameter (inches)	Number of additional turns required following hand tightening
2	1/8	1 ¼
3	3/16	1 ¼
4	1/4	1 ¼
5	5/16	1 ¾
6	3/8	2 ¼
8	1/2	2 ¼
10	5/8	2 ¼
12	3/4	2 ¼
16	1	2 ¼

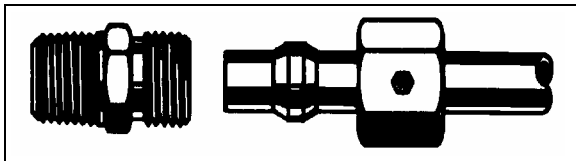

FIGURE 51: HOSE FITTING 12054

**NTA-Type Plastic Tubing:** Hand tighten nut (Fig. 52). From that point, tighten using a wrench the number of turns indicated in the following chart.

Tubing diameter (inches)	Number of additional turns required following hand tightening
1/4	3
3/8 to 1/2	4
5/8 to 3/4	3 ½

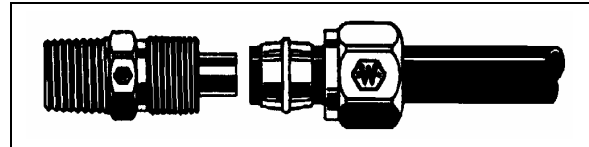

FIGURE 52: HOSE FITTING 12055

**AB-Type Copper Piping:** Hand tighten nut (Fig. 53). From that point, tighten with a wrench the number of turns indicated in the following chart.

Piping diameter (inches)	Number of additional turns required following hand tightening
1/4, 3/8, 1/2	2
5/8, 3/4	3

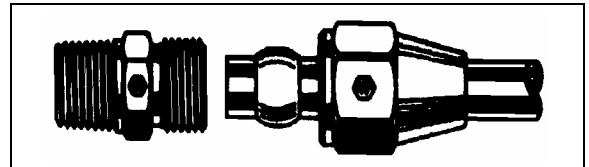

FIGURE 53: HOSE FITTING 12056

**Pipe Tightening:** All connections must be hand tightened. From that point, tighten a minimum of 2 ½ additional turns.

**NOTE**

Use Loctite (Prévost number 680098) pipe sealant to seal pipe thread.



## Section 12: BRAKE AND AIR SYSTEM

---

### 33. SPECIFICATIONS

#### Air Compressor

Make..... Bendix Westinghouse  
Model..... BA-921  
Capacity (at 1250 rpm) ..... 15.7 cfm (0,445 m<sup>3</sup>/min.)  
Supplier number ..... 801287  
Prévost number ..... 641990

#### BA-921 Service Kits

##### ST-4 Safety Valve

Supplier number ..... 800534  
Prévost number ..... 641989

##### Series 60 Seal Kit

Supplier number ..... 5012371  
Prévost number ..... 641988

##### Compressor Seal Kit

Supplier number ..... 5008559  
Prévost number ..... 641987

##### Cylinder Head Gasket Kit

Supplier number ..... 5008558  
Prévost number ..... 641986

#### Air Dryer

Make..... Haldex  
Model..... AT-87192  
Supplier number ..... 108229  
Prévost number ..... 70303498  
Desiccant cartridge Prévost number..... 3097369

#### Flip-Flop Control Valve

Make..... Bendix Westinghouse  
Model..... TW-1  
Type ..... On-Off  
Supplier number ..... 229635  
Prévost number ..... 640136

#### Emergency/Parking Brake Control Valve

Make..... Bendix Westinghouse  
Model..... PP-1  
Automatic release pressure ..... 40 psi (275 kPa) nominal  
Supplier number ..... 287325  
Prévost number ..... 641128

#### Dual Brake Application Valve

Make..... Bendix Westinghouse  
Model..... E-10P  
Supplier number ..... 5006280  
Prévost number ..... 641856

#### Stoplight Switches

Make..... Bendix Westinghouse  
Model..... SL-5  
Contact close (ascending pressure) ..... 4 psi and more (28 kPa)  
Supplier number ..... 286404  
Prévost number ..... 641462



**Brake Relay Valves**

Make..... Bendix Westinghouse  
 Model..... R-12  
 Supplier number.....  
 Prévost number.....

**Brake Relay Valve**

Make..... Meritor Wabco  
 Model..... R-14  
 Supplier number.....  
 Prévost number.....

**Quick Release Valve**

Make..... Bendix Westinghouse  
 Model..... QR-1  
 Supplier number..... 5001496  
 Prévost number..... 641429

**Spring Brake Valve**

Make..... Bendix Westinghouse  
 Model..... SR-7  
 Supplier number.....  
 Prévost number.....

**Pressure Protection Valve**

Make..... Bendix Westinghouse  
 Model..... PR-4  
 Nominal closing pressure..... 70 psi (482 kPa)  
 Supplier number..... 277226  
 Prévost number..... 641137

**Shuttle-Type Double Check Valve**

Make..... Bendix Westinghouse  
 Model..... DC-4  
 Supplier number..... 277988  
 Prévost number..... 641015

**Low Pressure Indicators**

Make..... Bendix Westinghouse  
 Model..... LP-3  
 Contact close ..... 66 psi (455 kPa)  
 Supplier number..... 277227  
 Prévost number..... 640975

**Air Pressure Regulator**

Make..... Norgren  
 Adjustable output range ..... 0-80/85 psi (0-552/586 kPa)  
 Recommended pressure setting ..... 75 psi (517 kPa)  
 Supplier number..... R06-2G7 RNKA  
 Prévost number..... 641472

**Air Filter Element**

Make..... Norgren  
 Type ..... With manual drain  
 Supplier number..... F74G-345-004  
 Prévost number..... 641338

## Section 12: BRAKE AND AIR SYSTEM

---

### Front Axle Brake Chambers

Make.....Knorr-Bremse  
Type ..... 24  
Supplier number (R.H.) ..... BS-3457 II 34671  
Prévost number (R.H.) ..... 641414  
Supplier number (L.H.) ..... BS-3457 II 34670  
Prévost number (L.H.) ..... 641413

### Drive Axle Brake Chambers

Make.....Knorr-Bremse  
Type ..... 24 as service -24 as emergency  
Supplier number ..... II/35699/BS-9524  
Prévost number ..... 641432

### Piggy Back (On Drive Brakes)

Make.....Knorr-Bremse  
Type ..... 24 as emergency  
Supplier number ..... II/17567/0061  
Prévost number ..... 641433

### Tag Axle Brake Chambers

Make.....Knorr-Bremse  
Type ..... 16 as service – 16 as emergency  
Supplier number ..... II/18224/V1-BS9396  
Prévost number ..... 641308

### Piggy Back (On Tag Brakes)

Make.....Knorr-Bremse  
Type ..... 16 as emergency  
Supplier number ..... II/18224/0061  
Prévost number ..... 641431

### Brake Lining (All Axles)

Make.....Knorr-Bremse  
Supplier number ..... II 33976  
Prévost number ..... 611049  
Prévost number ..... 641226

## ABS ANTILOCK BRAKING SYSTEM (if applicable)

### ABS MODULATOR VALVE

Make.....Rockwell Wabco  
Voltage ..... 24 V  
Supplier number ..... 472 195 006 0  
Prévost number ..... 641097

### Sensor, Front Axle

Supplier number ..... 441 032-572-0  
Prévost number ..... 641288

### Sensor, Drive Axle (In Wheel End)

Supplier number ..... 441 032-576-0  
Prévost number ..... 641095