

APPENDIX A

FIRE EXTINGUISHER REBUILD AND RECHARGING PROCEDURE HORIZONTAL DRY CHEMICAL

INTRODUCTION

This procedure describes rebuilding and recharging Fire Extinguisher P/N 413102-5X3Z. Choose the dry chemical according to the P/N code Z.

Dry chemical: Z=2 means use BC rated Purple-K; Z=3 means use ABC rated MAP.

Rebuilding consists of disassembly, cleaning and installation of new parts. Recharging consists of refilling and pressurizing the extinguisher to the specified level. Figure 1 identifies major components.

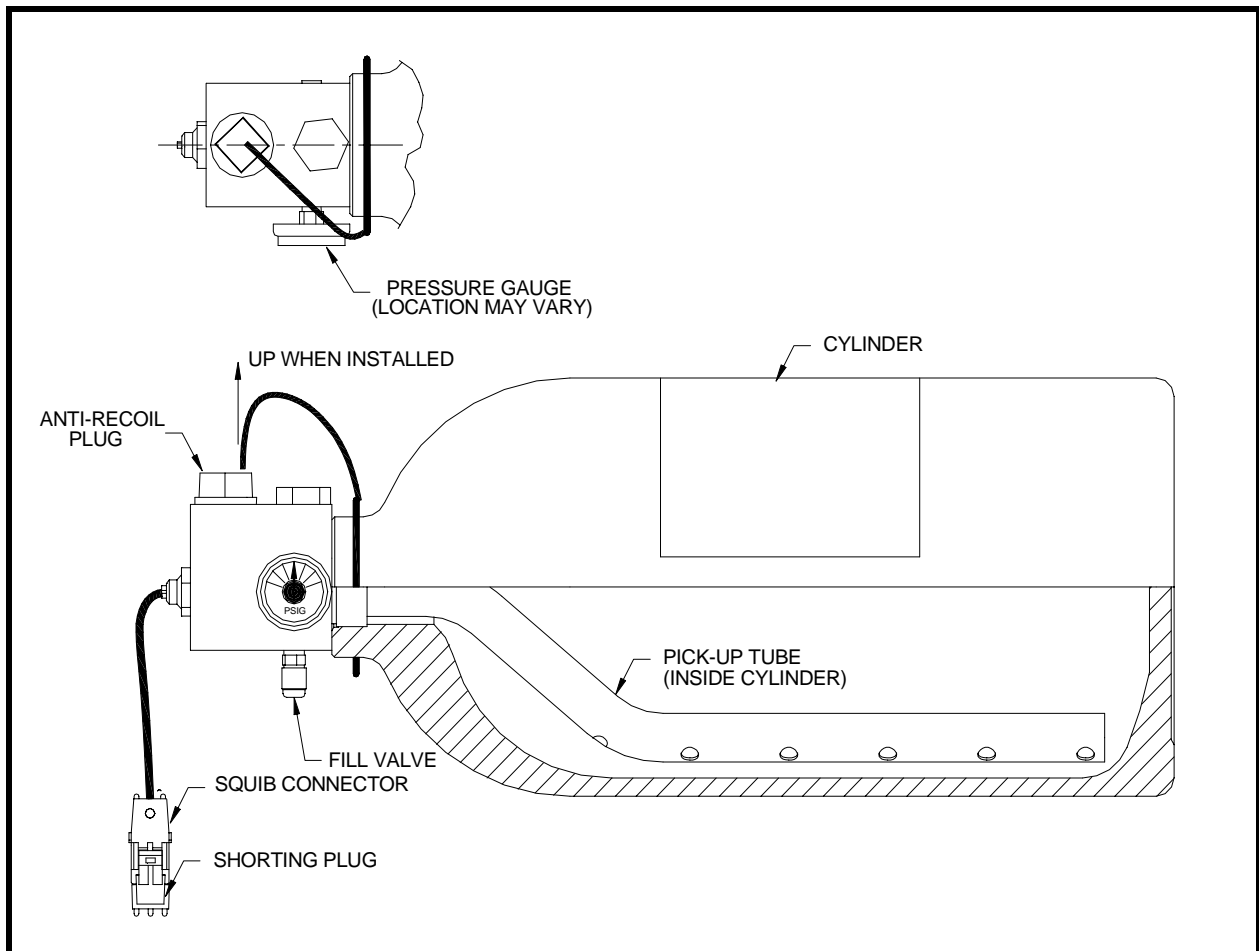

Figure 1. Extinguisher Configuration

WARNING

- EXTINGUISHER IS PRESSURIZED -

DO NOT HANDLE A FIRE EXTINGUISHER UNLESS THE ANTI-RECOIL PLUG IS INSTALLED IN THE VALVE OUTLET PORT AND THE SQUIB LEADS ARE SHORTED TOGETHER.

NOTE: An anti-recoil plug can be made from a 1 inch NPT pipe plug with two 3/32 inch diameter holes drilled through its end.

TOOL LIST

The following tools are available from Dual Spectrum®:

- Spanner, Retainer, P/N 91019-2
- Hose Adapter, Dry Chemical, P/N 421028

The following equipment is normally available at local fire extinguisher refilling companies:

- Platform scale, 100 lb. minimum capacity, 0.1 lb. readability
- Charging hoses rated 1000 psig minimum working pressure
- Nitrogen regulator with outlet gauge
- Bottle Clamp Stand or Bench Vise
- Torque wrench, 0 to 100 ft-lb. range
- Dow Corning Grease-MOLYKOTE 55M or equivalent
- LOCTITE 565 thread sealant or equivalent
- Torque Seal (Glyptol) or equivalent anti-tamper paint
- Vacuum Fill Station, Dry Chemical (Getz).

INITIAL PREPARATIONS

1. Inspect valve exterior for condition of anti-tamper paint at the fill valve cap, fill valve to body, DC fill plug, gauge to body, squib to body, plug to body, and valve to bottle joints. Note any indication of tampering and record on the fill log sheet.
2. Weight the assembly before disassembly. Record received weight on the fill log sheet.
3. Bleed residual pressure from the extinguisher through the fill valve. To minimize agent loss, orient cylinder so that the arrow on the valve points downward. Figure 2 identifies valve components.

CAUTION

DO NOT ATTEMPT TO EMPTY THE EXTINGUISHER BY APPLYING VOLTAGE TO THE SQUIB CONNECTOR. BLEED PRESSURE THROUGH THE FILL VALVE.

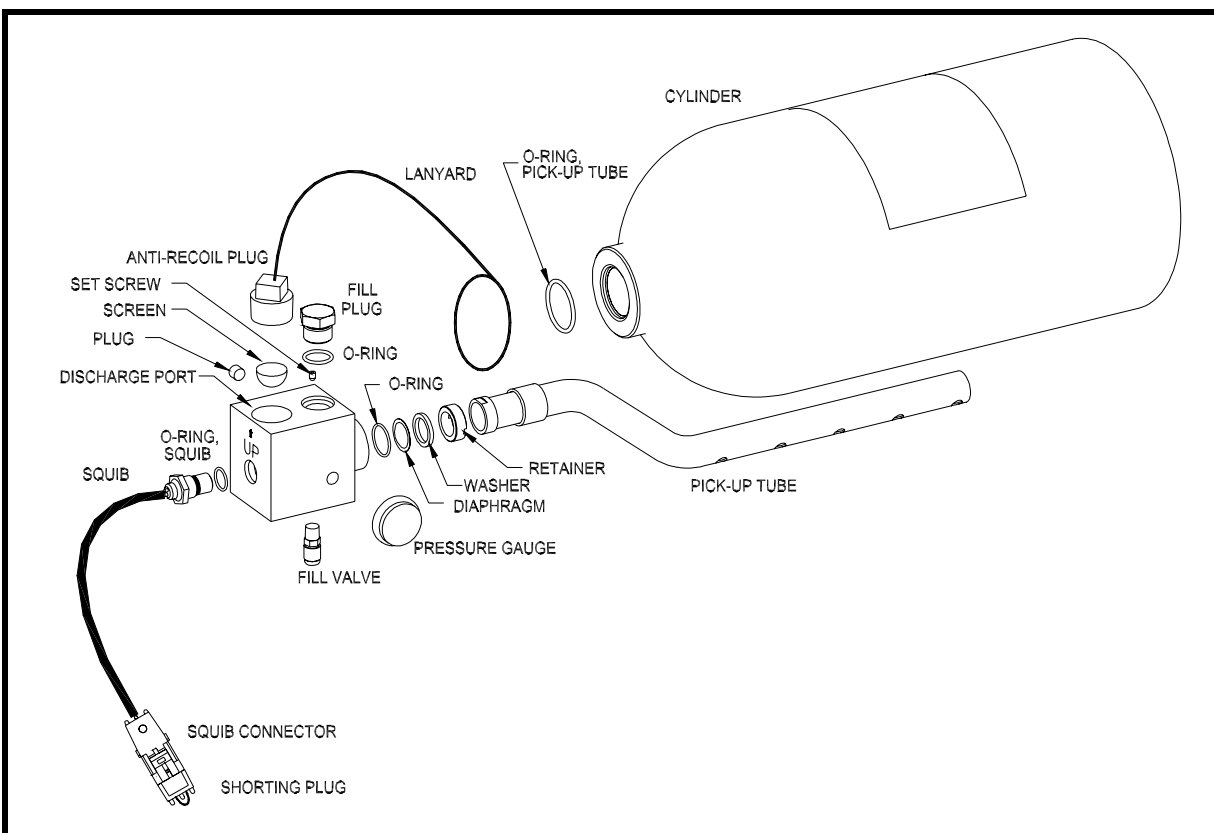

Figure 2. Valve Components

Kidde Dual Spectrum

4. Unscrew the valve at the cylinder neck and remove valve and pick-up tube assembly. (Note that this is difficult to do if the cylinder is still filled with agent as the dip tube must move through the dry chemical.)
5. Inspect interior of cylinder and remove any debris left after the discharge.
6. Check the approval date stamped on the cylinder shoulder. It must be within five years of the current date. If the cylinder is out of date it must be hydrostatically tested and re-certified before it can be filled.

VALVE REBUILD AND RECHARGING PROCEDURE

REBUILD PARTS REQUIRED

Each valve rebuild kit P/N 406262-1 consists of these parts:

1 each	Diaphragm
1 each	Squib (Detonator)
1 each	Shorting plug
1 each	O-ring, Diaphragm
1 each	O-ring, Squib
2 each	O-ring, Inlet Port
1 each	Fill Valve
1 each	O-ring, Fill Port

DISASSEMBLE VALVE

Refer to Figure 2 for location of parts.

1. Mount valve in a vise.
2. Remove plug below outlet port.
3. Using 1/8" Allen wrench, loosen pick-up tube set screw.
4. Unscrew the pick-up tube from the inlet port of the valve body.
5. Using spanner wrench 91019-2, unscrew the retainer from the inlet port.
6. Remove and discard the used squib, diaphragm and O-ring seals.
7. Clean port surfaces, screen, retainer, and washer and remove any debris from valve.

ASSEMBLE VALVE

Refer to Figure 2 & 3 for location of parts.

CAUTION
**BEFORE HANDLING SQUIB MAKE SURE
THE SHORTING PLUG IS INSTALLED ON
THE SQUIB CONNECTOR.**

1. Lubricate and install a new diaphragm O-ring seal into the groove of the inlet port.
2. Lubricate the new diaphragm and insert it into the port, on top of the O-ring. See Figure 3 for orientation. Incorrect diaphragm orientation may cause failure.

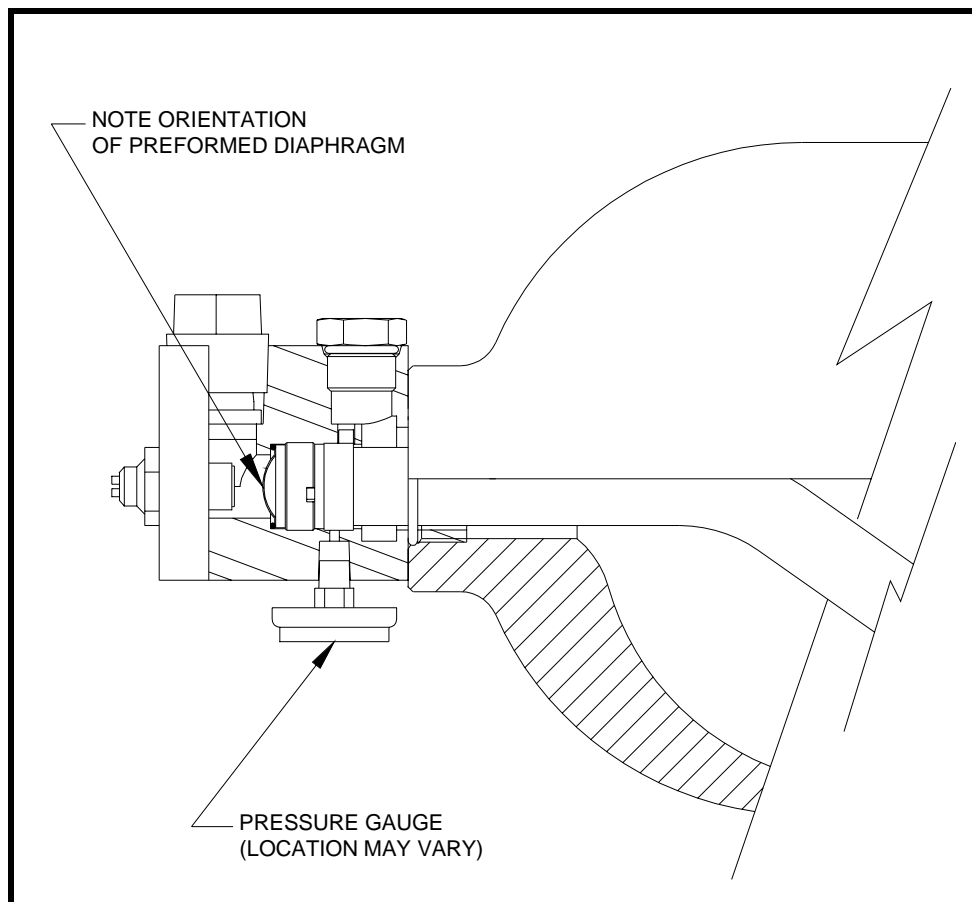

Figure 3. Diaphragm Orientation

3. Place washer on top of diaphragm and install threaded retainer.
4. Tighten retainer to 55 ft-lb with the retainer spanner and torque wrench.
5. Inspect the fill valve for damage or possible leakage. Replace fill valve if necessary.
6. Screw pick-up tube into valve fully, back out until the tube is oriented such that the bend and pick-up holes face away from the outlet port. Ensure the flat surface on the tube threads is lined up with set screw. The set screw has a self locking nylon patch on it's threads. Torque set screw to 40-45 inch pounds.
7. Install squib (detonator), with squib O-ring, into the valve body and wrench tighten.
8. Inspect the pressure gauge for proper zero reading (near white dot), if the gauge is defective, replace it with a new gauge P/N 408548. Install gauge with LOCTITE 565 thread sealant or equivalent — wrench tight.
9. Install new O-ring on the inlet port, and lubricate with Molykote grease.
10. Place anti-recoil plug lanyard around neck of cylinder. Install valve to cylinder, and torque to 50 ± 0.5 ft.-lbs.
11. Look at the screen in the outlet port. If the screen looks like the obsolete item in Figure 3, replace it with P/N 406250. Check that the discharge screen is installed in the discharge port with its dished side inward and install the anti-recoil plug into the discharge port.

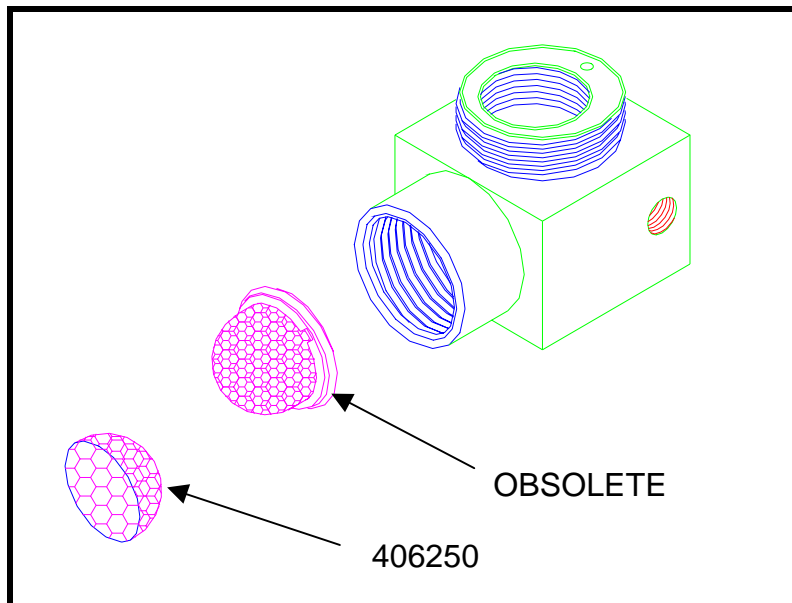

Figure 4. Discharge Screen Styles

12. NOTE: Always remove old fill valve core, discard, clean internal fill-valve body and install new core. If installing new fill valve, use Loctite 565 thread sealant or equivalent.

DRY CHEMICAL FILL

1. Record empty weight of extinguisher (cylinder and valve), to within 0.1 lb.
2. Remove fill plug (hex head) and place dry chemical fill adapter 421028 into the fill port. (The adapter can be made by combining a 3/8 inch hose barb with an extra fill plug.) See Figure 5.

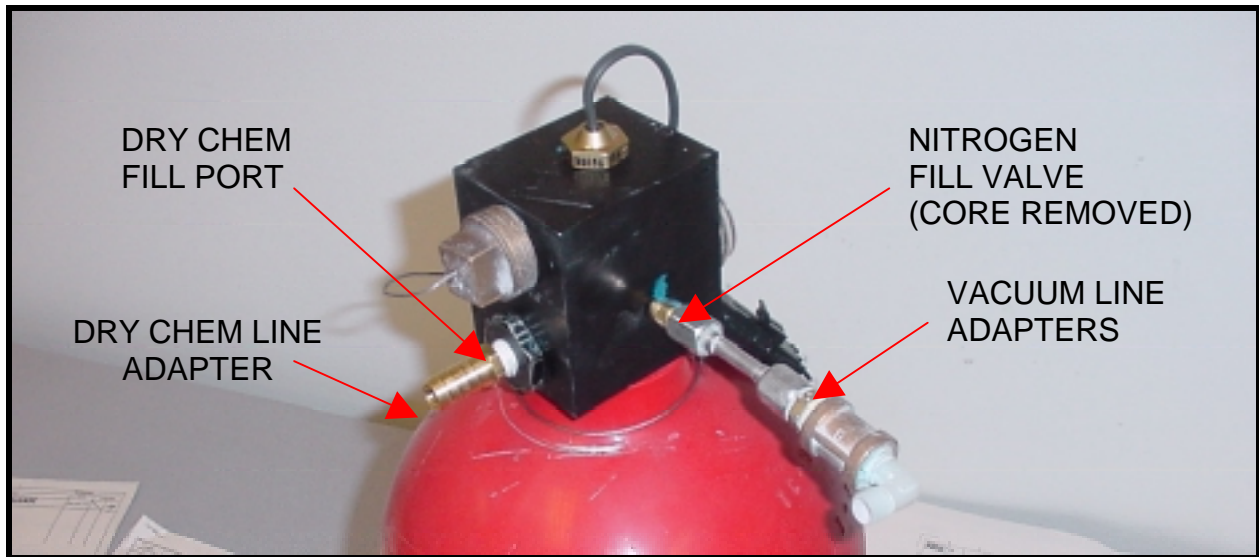

Figure 5. Dry Chemical Fill Adapter Fittings

3. Remove core from fill valve and attach vacuum hose from the vacuum fill station using appropriate adapter fittings.
4. With extinguisher in place, tare scale and proceed to fill assembly with 22 ± 0.1 lbs. of the dry chemical agent shown on the cylinder label.
5. Remove hoses and adapters. Clean fill port of excess agent, replace o-ring on fill port plug, lubricate seal, and torque plug to 40 ± 0.5 ft-lbs.
6. Clean nitrogen fill valve and reinstall its core.

PRESSURIZE CYLINDER

WARNING

ANTI-RECOIL PLUG MUST BE INSTALLED IN THE DISCHARGE PORT PRIOR TO PRESSURIZING UNIT.

1. Attach nitrogen supply hose to the fill valve.
2. Pressurize extinguisher to 360 psi (correct pressure at 70°F) with dry nitrogen.
3. Remove hose from extinguisher.
4. Perform leak check to all valve components, including valve core and valve seat at cylinder, using an Air-Gas leak detection fluid.
5. Weigh the full extinguisher to +/- 0.1 lbs. accuracy. Record empty weight, full weight, date and operator initials on the service tag and on the fill log sheet.
6. Apply anti-tamper paint at the fill valve cap, fill valve to body, DC fill plug, gauge to body, squib to body, plug to body, and valve to bottle joints. Figure 5 illustrates typical installation of this paint.

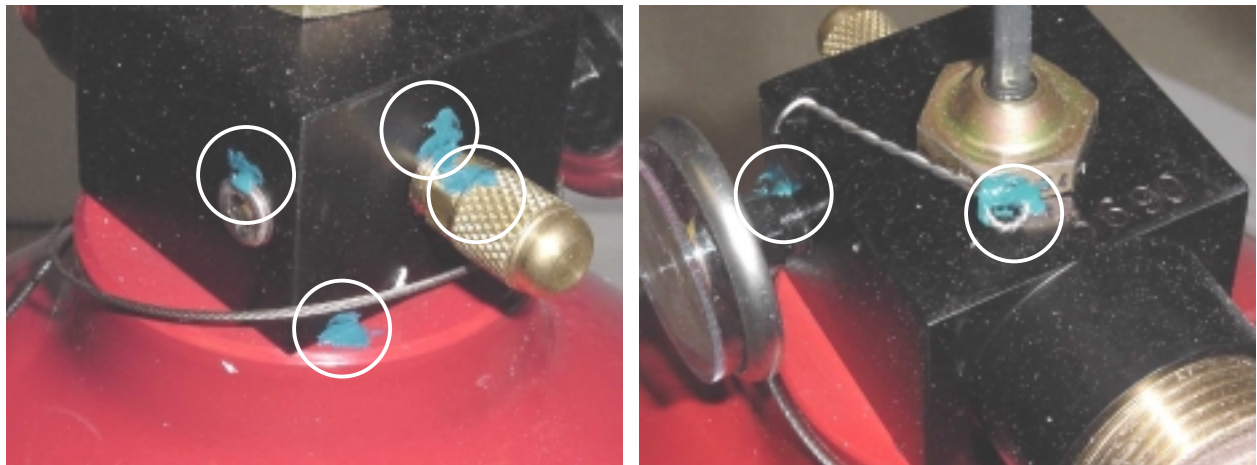

Figure 5. Anti-tamper Paint Spots

REPLACEMENT PARTS

Valve Rebuild Kit, P/N 406262-1

Cylinder, P/N 408234

Fill Valve, P/N 409592

Pressure Gauge, P/N 408548

Anti-recoil Assembly, P/N 408369

Shorting Plug, P/N 406317

Set Screw, 1/4 -28 UNF X 3/8, Self-locking, flat point, 94495A253

Screen, 406250.