



Service Data

SD-08-2412

AD-9 AIR DRYER

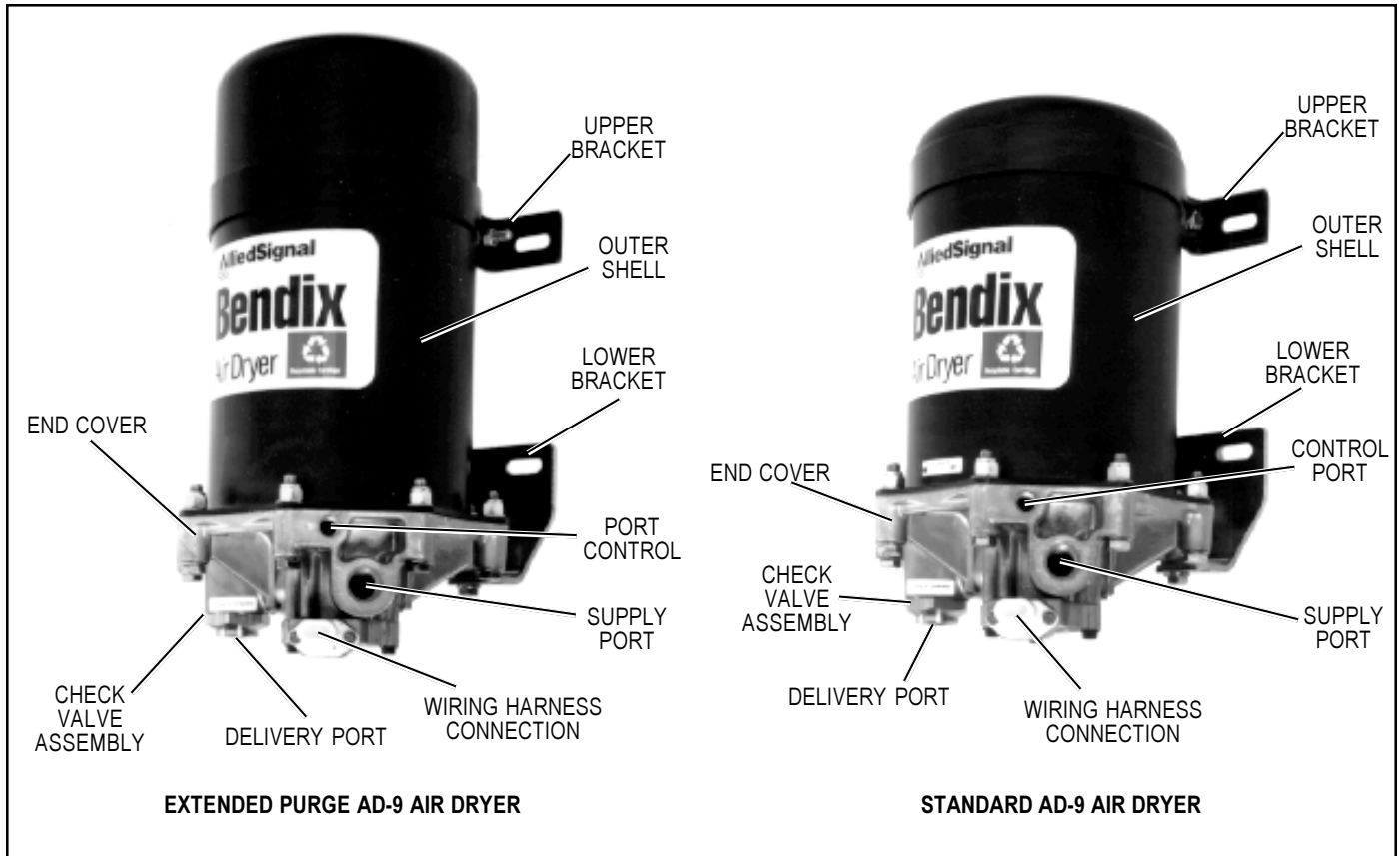

FIGURE 1 - AD-9 AIR DRYER MODELS

DESCRIPTION

The function of the AD-9 Air Dryer is to collect and remove air system contaminants in solid, liquid and vapor form before they enter the brake system. It provides clean, dry air to the components of the brake system which increases the life of the system and reduces maintenance costs. Daily manual draining of the reservoirs is eliminated.

The AD-9 Air Dryer consists of a desiccant cartridge and a die cast aluminum end cover secured to a cylindrical steel outer shell with eight cap screws and nuts. The end cover contains a check valve assembly, a safety valve, three threaded air connections and the purge valve housing assembly. The removable purge valve housing assembly incorporates a purge valve mechanism and a turbo charger cut-off feature that is designed to prevent loss of engine "turbo" boost pressure during the purge cycle of the AD-9

air dryer. For ease of serviceability, the desiccant cartridge and discharge check valve assembly are screw in type. The purge valve housing assembly, which includes the heater and thermostat assembly, and the discharge check valve assembly, is serviceable from the exterior of the air dryer, while servicing the screw-in desiccant cartridge requires removal of the air dryer assembly from the vehicle.

The AD-9 has three female pipe thread air connections and each is identified as follows:

Port I.D.	Function/Connection
CON 4	Control Port (purge valve control and turbo cut-off).
SUP 11	Supply Port (air in).
DEL 2	Delivery Port (air out).

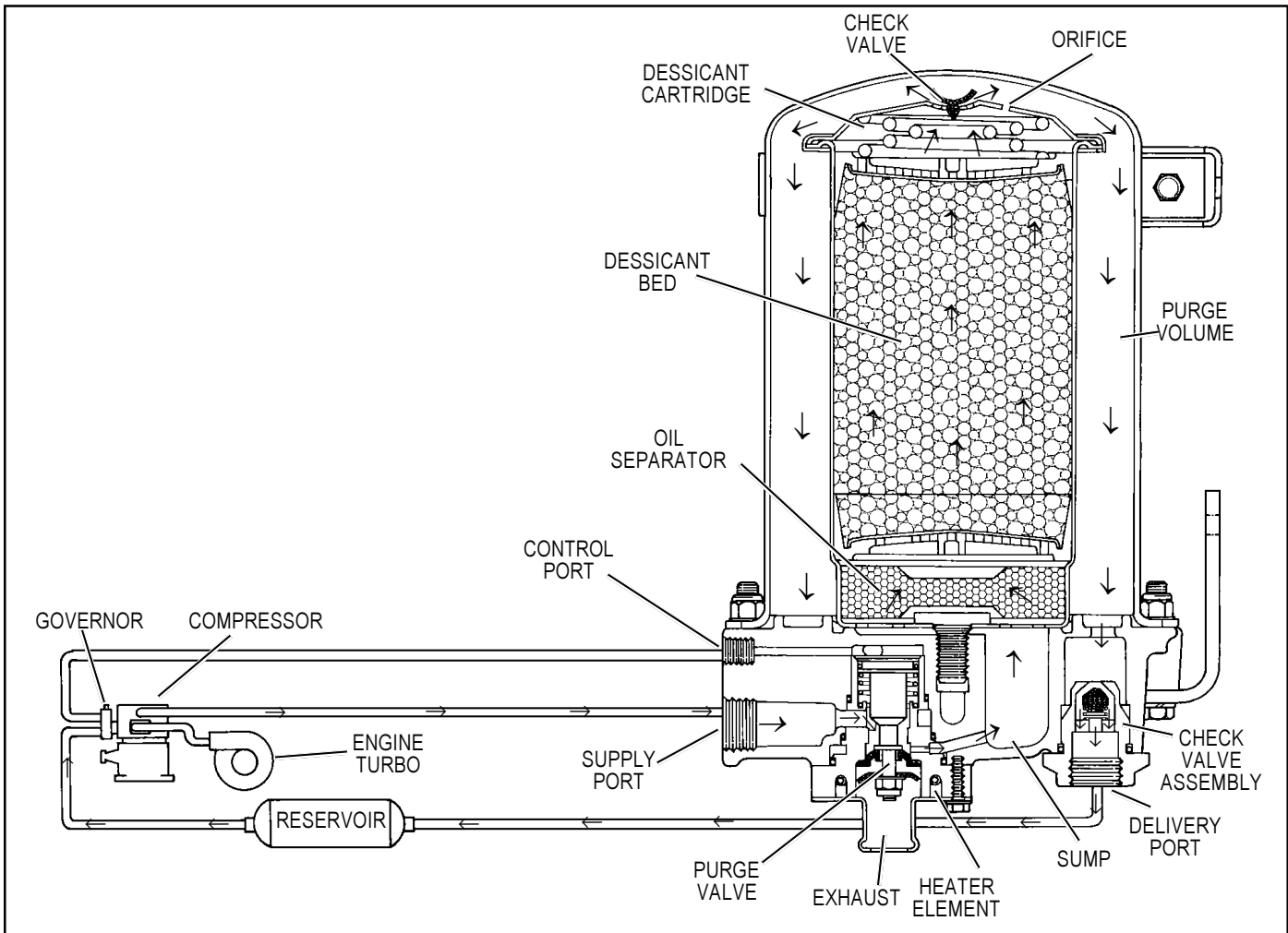

FIGURE 2 - AD-9 CHARGE CYCLE

OPERATION OF THE AD-9 AIR DRYER

The AD-9 air dryer alternates between two operational modes or “cycles” during operation: the *charge cycle* and the *purge cycle*. The following description of operation is separated into these “cycles” of operation.

CHARGE CYCLE (refer to Figure 2)

When the compressor is loaded (compressing air) compressed air, along with oil, oil vapor, water and water vapor flows through the compressor discharge line to the supply port of the air dryer end cover. As air travels through the end cover assembly, its direction of flow changes several times, reducing the temperature, causing contaminants to condense and drop to the bottom or sump of the air dryer end cover.

After exiting the end cover, the air flows into the desiccant cartridge. Once in the desiccant cartridge air first flows through an oil separator which removes water in liquid form as well as oil, oil vapor and solid contaminants.

Air exits the oil separator and enters the desiccant drying bed. Air flowing through the column of desiccant becomes

progressively dryer as water vapor adheres to the desiccant material in a process known as “adsorption”. The desiccant cartridge using the adsorption process typically removes 95% of the water vapor from the pressurized air.

The majority of dry air exits the desiccant cartridge through its integral single check valve to fill the purge volume between the desiccant cartridge and outer shell. Some air will also exit the desiccant cartridge through the purge orifice adjacent to the check valve.

Dry air flows out of the purge volume through the single check valve assembly and out the delivery port to the first (supply) reservoir of the air system.

The air dryer will remain in the charge cycle until air brake system pressure builds to the governor cutout setting.

PURGE CYCLE (refer to Figure 3)

When air brake system pressure reaches the cutout setting of the governor, the compressor unloads (air compression stopped) and the purge cycle of the air dryer begins. When the governor unloads the compressor, it pressurizes the compressor unloader mechanism and line

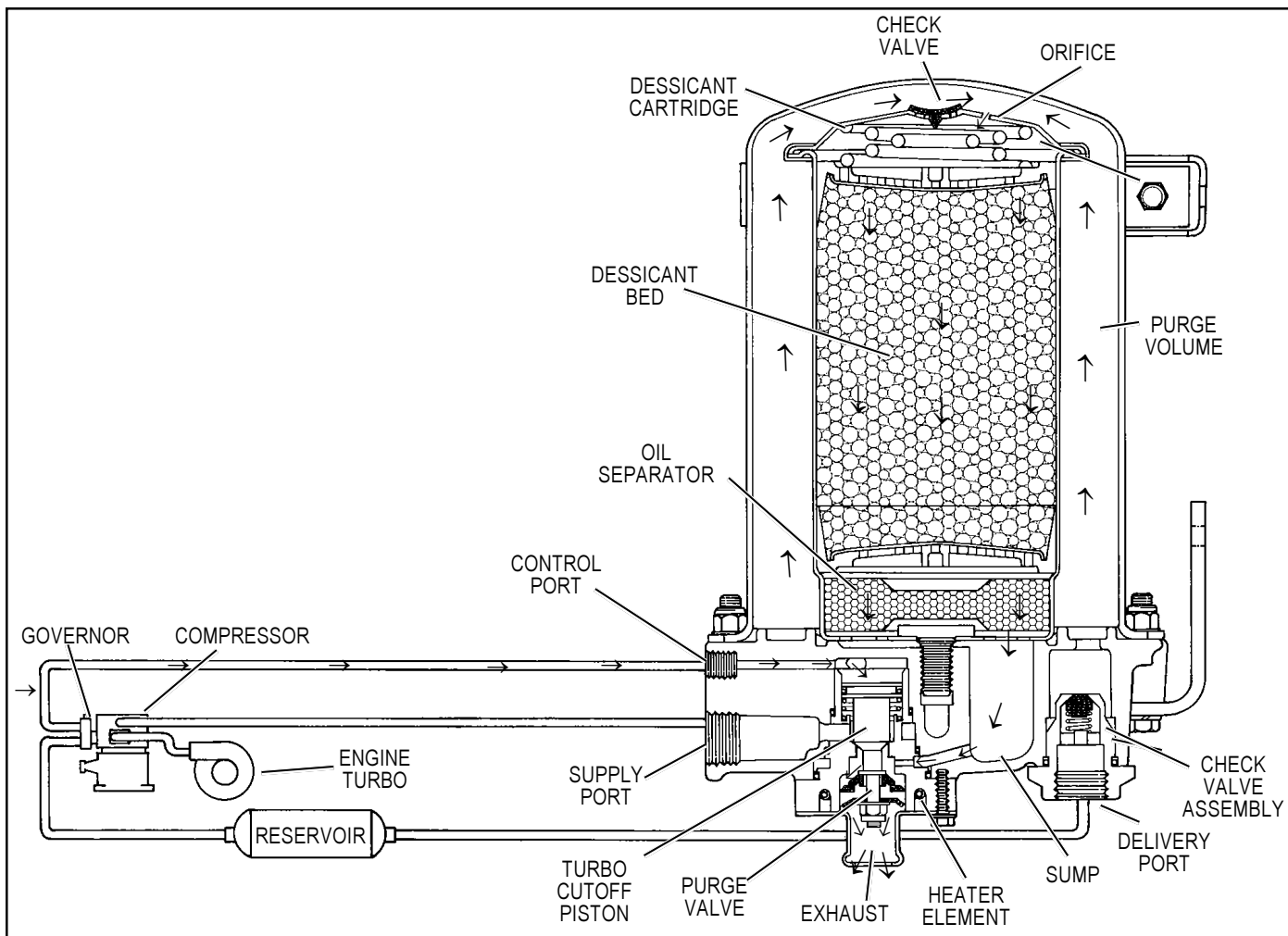

FIGURE 3 - AD-9 PURGE CYCLE

connecting the governor unloader port to the AD-9 end cover control port. The purge piston moves in response to air pressure causing the purge valve to open to atmosphere and (partially) closing off the supply of air from the compressor, this will be further discussed in the section covering the turbo cut-off feature. Contaminants in the end cover sump are expelled immediately when the purge valve opens. Also, air which was flowing through the desiccant cartridge changes direction and begins to flow toward the open purge valve. Oil and solid contaminants collected by the oil separator are removed by air flowing from the desiccant drying bed to the open purge valve.

The initial purge and desiccant cartridge decompression lasts only a few seconds and is evidenced by an audible burst of air at the AD-9 exhaust.

The actual reactivation of the desiccant drying bed begins as dry air flows from the purge volume through the desiccant cartridge purge orifice and into the desiccant drying bed. Pressurized air from the purge volume expands after passing through the purge orifice; its pressure is lowered and its volume increased. The flow of dry air through the drying bed reactivates the desiccant material by remov-

ing the water vapor adhering to it. Generally 15-30 seconds are required for the entire purge volume of a standard AD-9 to flow through the desiccant drying bed.

The end cover single check valve assembly prevents air pressure in the brake system from returning to the air dryer during the purge cycle. After the 30 second purge cycle is complete, the air dryer is ready for the next charge cycle to begin.

The purge valve will remain open after the purge cycle is complete and will not close until air brake system pressure is reduced and the governor signals the compressor to charge.

TURBO CUT-OFF FEATURE (Refer to Figure 4)

The primary function of the turbo cut-off valve is to prevent loss of engine turbocharger air pressure through the AD-9 in systems where the compressor intake is connected to the engine turbocharger. The turbo cut-off valve also reduces the "puffing" of air out the open exhaust when a naturally aspirated, single cylinder compressor equipped with an inlet check valve is in use.

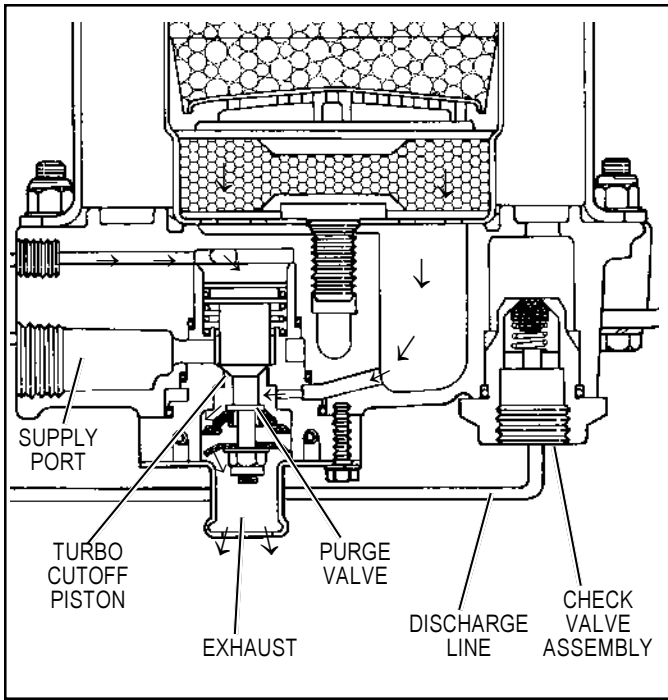

FIGURE 4 - AD-9 TURBO CUTOFF

At the onset of the purge cycle, the downward travel of the purge piston is stopped when the turbo cut-off valve (tapered portion of purge piston) contacts its mating metal seat in the purge valve housing. With the turbo cut-off valve seated (closed position), air in the discharge line and AD-9 inlet port is restricted from entering the air dryer. While the turbo cut-off effectively prevents loss of turbo charger boost pressure to the engine, some "seepage" of air may be detected under certain conditions of compressor engine and turbo charger operation, even so there will always be low pressure trapped in the discharge line.

PREVENTIVE MAINTENANCE

Important: Review the warranty policy before performing any intrusive maintenance procedures. An extended warranty may be voided if intrusive maintenance is performed during this period.

Because no two vehicles operate under identical conditions, maintenance and maintenance intervals will vary. Experience is a valuable guide in determining the best maintenance interval for any one particular operation.

Every 900 operating hours or 25,000 miles or every three (3) months:

1. Check for moisture in the air brake system by opening reservoirs, drain cocks, or valves and checking for presence of water. If moisture is present, the desiccant may require replacement; however, the following conditions can also cause water accumulation and should be considered before replacing the desiccant:
 - A. An outside air source has been used to charge the system. This air did not pass through the drying bed.

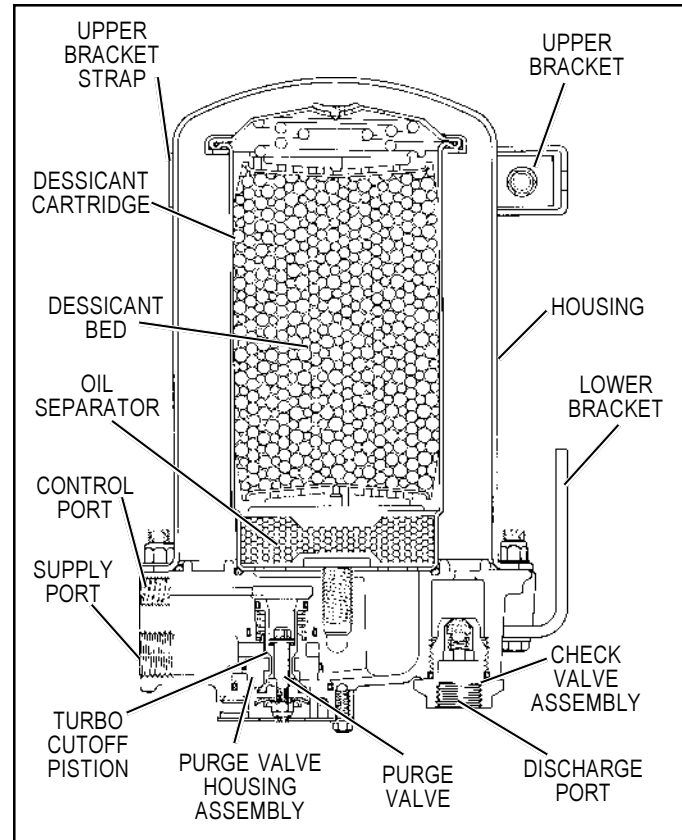

FIGURE 5 - AD-9 AIR DRYER SECTIONAL VIEW

- B. Air usage is exceptionally high and not normal for a highway vehicle. This may be due to accessory air demands or some unusual air requirement that does not allow the compressor to load and unload (compressing and non-compressing cycle) in a normal fashion. Check for high air system leakage.
- C. The air dryer has been installed in a system that has been previously used without an air dryer. This type system will be saturated with moisture and several weeks of operation may be required to dry it out.
- D. Location of the air dryer is too close to the air compressor. Refer to *Locating AD-9 On Vehicle* section.
- E. In areas where more than a 30 degree range of temperature occurs in one day, small amounts of water can accumulate in the air brake system due to condensation. Under these conditions, the presence of small amounts of moisture is normal and should not be considered as an indication that the dryer is not performing properly.

Note: A small amount of oil in the system may be normal and should not, in itself, be considered a reason to replace the desiccant; oil stained desiccant can function adequately.

2. Check mounting bolts for tightness. Retorque to 270-385 inch pounds.

3. Perform the *Operation & Leakage Tests* listed in this publication.

Every 10,800 hours; 300,000 miles or 36 months:

1. Rebuild the air dryer including the desiccant cartridge.

Note: The desiccant change interval may vary from vehicle to vehicle. Although typical desiccant cartridge life is three years, many will perform adequately for a longer period of time. In order to take maximum advantage of desiccant life and assure that replacement occurs only when necessary, it is important that *Operation & Leakage Tests* be performed.

OPERATION & LEAKAGE TESTS

1. Test the outlet port check valve assembly by building the air system to governor cut-out and observing a test air gauge installed in the #1 reservoir. A rapid loss of pressure could indicate a failed outlet port check valve. This can be confirmed by bleeding the system down, removing the check valve assembly from the end cover, subject air pressure to the unit and apply a soap solution to the check valve side. Leakage should not exceed a 1 inch bubble in 1 second.
2. Check for excessive leakage around the purge valve. With the compressor in loaded mode (compressing air), apply a soap solution to the purge valve housing assembly exhaust port and observe that leakage does not exceed a 1 inch bubble in 1 second. If the leakage exceeds the maximum specified, service the purge valve housing assembly.
3. Close all reservoir drain cocks. Build up system pressure to governor cut-out and note that AD-9 purges with an audible escape of air. "Fan" the service brakes to reduce system air pressure to governor cut-in. Note that the system once again builds to full pressure and is followed by an AD-9 purge.
4. Check the operation of the safety valve by pulling the exposed stem while the compressor is loaded (compressing air). There must be an exhaust of air while the stem is held and the valve should reseat when the stem is released.
5. Check all lines and fittings leading to and from the air dryer for leakage and integrity.
6. Check the operation of the end cover heater and thermostat assembly during cold weather operation as follows:

A. Electric Power to the Dryer

With the ignition or engine kill switch in the ON position, check for voltage to the heater and thermostat assembly using a voltmeter or test light. Unplug the electrical connector at the air dryer and place the test leads on each of the pins of the male

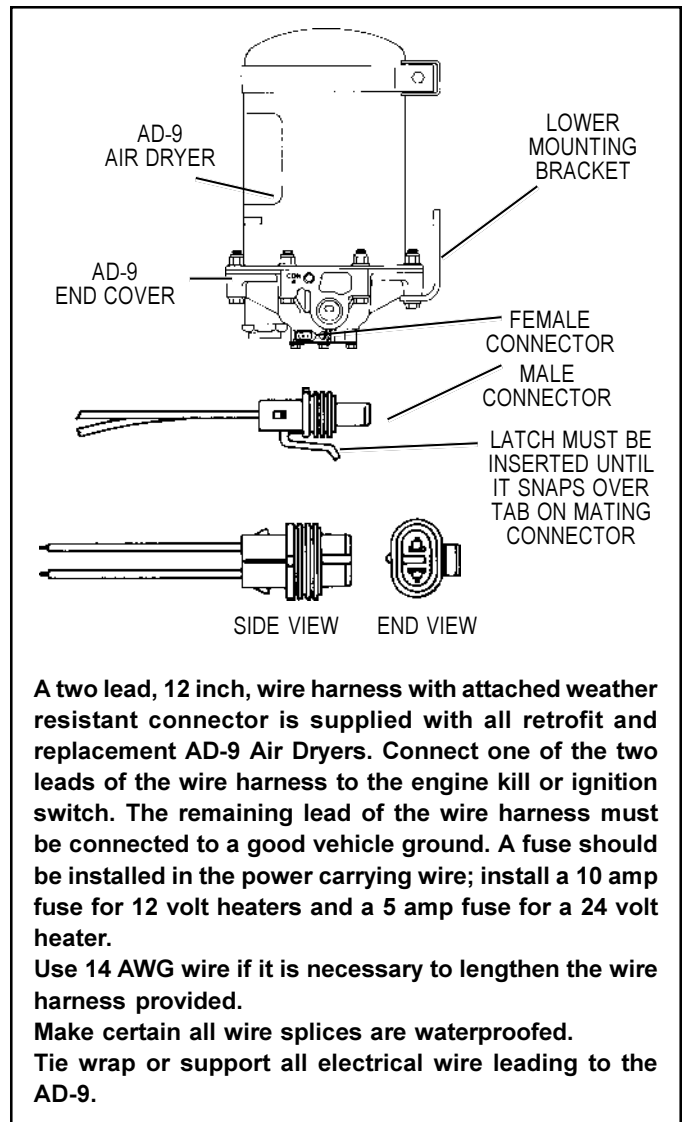

FIGURE 6 - HEATER AND THERMOSTAT CONNECTOR

connector. If there is no voltage, look for a blown fuse, broken wires, or corrosion in the vehicle wiring harness. Check to see if a good ground path exists.

B. Thermostat and Heater Operation

Turn off the ignition switch and cool the end cover assembly to below 40 degrees Fahrenheit. Using an ohmmeter, check the resistance between the electrical pins in the female connector. The resistance should be 1.5 to 3.0 ohms for the 12 volt heater assembly and 6.8 to 9.0 ohms for the 24 volt heater assembly. **Note:** Some early models of the AD-9 will have resistance readings of 1.0 to 2.5 ohms for the 12 volt heater assembly and 4.8 to 7.2 ohms for the 24 volt heater assembly. If the resistance is higher than the maximum stated, replace the purge valve housing assembly, which includes the heater and thermostat assembly.

Warm the end cover assembly to over 90 degrees Fahrenheit and again check the resistance. The

resistance should exceed 1000 ohms. If the resistance values obtained are within the stated limits, the thermostat and heater assembly is operating properly. If the resistance values obtained are outside the stated limits, replace the purge valve housing assembly, which includes the heater and thermostat assembly.

REBUILDING THE AD-9 AIR DRYER

GENERAL

If, after completing the routine operation and leakage tests, it has been determined that one or more components of the air dryer requires replacement or maintenance, refer to the following list to find the appropriate kit(s).

When rebuilding or replacing components of the air dryer use only genuine Bendix parts. For ease in servicing the AD-9 desiccant cartridge assembly, it is recommended that the air dryer be removed from the vehicle.

MAINTENANCE KITS AVAILABLE:

- 107798 [Purge Valve Housing Maintenance Kit](#)
This kit contains the parts necessary to rebuild the air portion of the purge valve housing and does not include the heater and thermo.
- 107794 [Desiccant Cartridge Replacement Kit](#)
This kit contains the parts necessary to change the desiccant cartridge only.
- 107796 [Remanufactured Desiccant Cartridge Replacement Kit](#)
This kit contains the parts necessary to change the desiccant cartridge only.
- 107799 [End Cover Check Valve Assembly Replacement](#)
3/4 inch thread size.
- 107800 [End Cover Check Valve Assembly Replacement](#)
1/2 inch thread size.
- 107896 [Service New or Remanufactured Exchange Purge Valve Housing Assembly](#)
(w/heater and thermo.) 12 volt system.
- 107897 [Service New or Remanufactured Exchange Purge Valve Housing Assembly](#)
(w/heater and thermo.) 24 volt system.
- 107695 [Complete Mounting Bracket Kit](#)
This kit contains the upper and lower brackets as well as the necessary hardware items to mount them.

IMPORTANT! PLEASE READ

When working on or around a vehicle, the following general precautions should be observed:

1. **Park the vehicle on a level surface, apply the parking brakes, and always block the wheels.**
2. **Stop the engine when working around the vehicle.**

3. **If the vehicle is equipped with air brakes, make certain to drain the air pressure from all reservoirs before beginning ANY work on the vehicle.**
4. **Following the vehicle manufacturer's recommended procedures, deactivate the electrical system in a manner that removes all electrical power from the vehicle.**
5. **When working in the engine compartment the engine should be shut off. Where circumstances require that the engine be in operation, EXTREME CAUTION should be used to prevent personal injury resulting from contact with moving, rotating, leaking, heated, or electrically charged components.**
6. **Never connect or disconnect a hose or line containing pressure; it may whip. Never remove a component or plug unless you are certain all system pressure has been depleted.**
7. **Never exceed recommended pressures and always wear safety glasses.**
8. **Do not attempt to install, remove, disassemble or assemble a component until you have read and thoroughly understand the recommended procedures. Use only the proper tools and observe all precautions pertaining to use of those tools.**
9. **Use only genuine Bendix replacement parts, components, and kits. Replacement hardware, tubing, hose, fittings, etc. should be of equivalent size, type, and strength as original equipment and be designed specifically for such applications and systems.**
10. **Components with stripped threads or damaged parts should be replaced rather than repaired. Repairs requiring machining or welding should not be attempted unless specifically approved and stated by the vehicle or component manufacturer.**
11. **Prior to returning the vehicle to service, make certain all components and systems are restored to their proper operating condition.**

AD-9 REMOVAL

1. Park the vehicle on a level surface and prevent movement by means other than the brakes.
2. Drain all reservoirs to 0 p.s.i. (0 kPa).— Caution: Compressor discharge line may still contain residual pressure.
3. Identify and disconnect the three air lines from the end cover and note the position of end cover ports relative to the vehicle.
4. Unplug the vehicle wiring harness from the heater and thermostat assembly connector on the purge valve housing assembly.

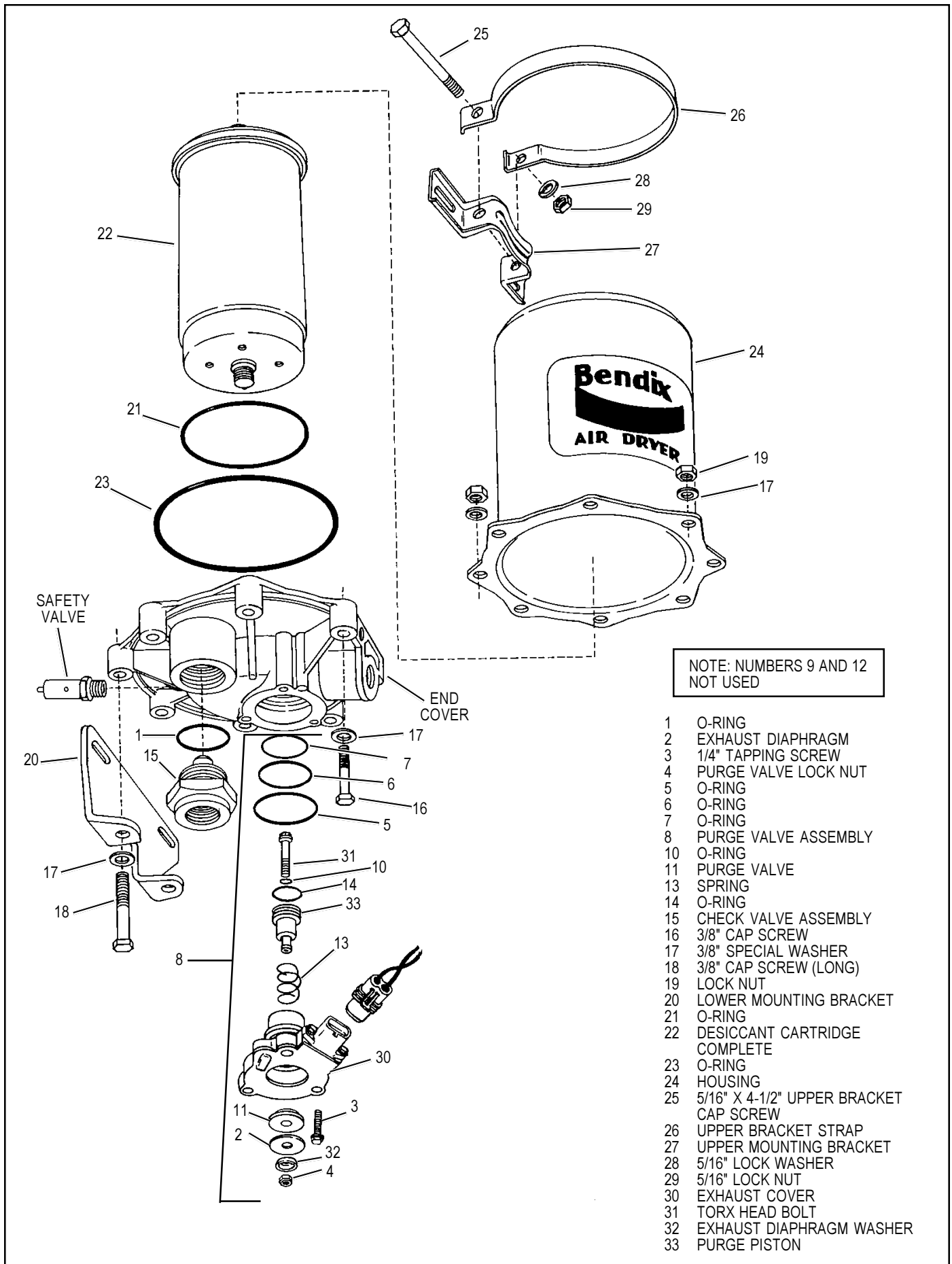

FIGURE 7 - AD-9 AIR DRYER ASSEMBLY

5. Loosen the 5/16" X 4-1/2" hex bolt securing the upper mounting strap.
6. Remove, retain and mark the two 3/8" end cover cap screws, lock nuts and four special washers that retain the lower mounting bracket to the end cover, also mark these two holes of the end cover. (These bolts are longer than the other 6 bolts.)
7. Remove the AD-9 air dryer from its mounting brackets on the vehicle.

DISASSEMBLY

The following disassembly and assembly procedure is presented for reference purposes and presupposes that a major rebuild of the AD-9 is being undertaken. Several replacement parts and maintenance kits are available which do not require full disassembly. The instructions provided with these parts and kits should be followed in lieu of the instructions presented here. Refer to Figure 7 during disassembly.

Caution: While performing service on the AD-9 air dryer, it is not recommended that a clamping device (vise, C-clamp, etc.) be used to hold any die cast aluminum component as damage may result. To hold the end cover, install a pipe nipple in the supply port and clamp the nipple into a vise.

1. Using an adjustable wrench or an 1-3/4" socket, remove the delivery, check valve assembly (15) and o-ring. Remove the o-ring from the check valve assembly.
2. Remove the three 1/4" self tapping screws (3) that secure the purge valve housing assembly to the end cover assembly. Pull the purge valve housing assembly out of the end cover assembly. Remove the three o-rings (5, 6 & 7) from the exterior of the purge valve housing assembly. **Note:** O-rings 5 and 6 may be lodged in the end cover bores, if so, they must be removed

3. Purge Valve Disassembly:

Note: In most cases a flat (non-extended) exhaust cover (30) is used. This cover should be left intact while servicing the purge valve housing assembly. However, if an extended type exhaust cover is in use to accommodate the attachment of an exhaust hose, the exhaust cover must be carefully peeled off the purge valve housing. **Use a thin flat blade to pry the exhaust cover off, taking care not to damage the potting material (RTV sealant) under the cover.** To remove the piston from the purge valve housing assembly requires a special Torx head socket or a twelve point 1/4" socket to hold the head of the purge valve bolt (31).

- A. Remove the 1/4" nut (4) from the bottom of the purge valve housing assembly using a 9/16" socket

wrench and a Torx head socket to hold the head of the bolt (31). Remove the diaphragm washer (32) (if present), and the diaphragm (2) (if present), and the purge valve (11) from the purge valve housing.

- B. Remove the 1/4" Torx head bolt (31) from the opposite end, then the purge piston (33), the return spring (13) and two o-rings (10 & 14); one on the O.D. and the other in the inside of the purge piston.
- C. Heater and Thermostat Assembly Replacement.

Caution: Do not attempt to remove this assembly, as it will be damaged during the removal process and is **not available as a service part**. If the heater and thermostat are defective, replace the entire purge valve housing assembly which includes these items.

4. Remove the remaining six 3/8" cap screws (16), lock nuts (19) and twelve special washers (17) that secure the end cover to the housing (24). Separate the end cover and desiccant cartridge (22) from the housing (24).
5. Remove the end cover to outer housing o-ring (23).
6. Do not remove the safety valve from the end cover unless it has been proven defective. If replacement is required, apply thread sealant or teflon tape on the threads of the replacement valve and torque to 120-400 in. lbs.
7. Place a strap or chain wrench around the desiccant cartridge (22) so that it is approximately 2-3 inches away from the end cover. Rotate the cartridge counterclockwise until it completely separates from the end cover. **Note:** A substantial torque (up to 50 lb. ft.) may be required to perform this disassembly.
8. Remove the desiccant cartridge o-ring (21) from the end cover.

CLEANING & INSPECTION

1. Using mineral spirits or an equivalent solvent, clean and thoroughly dry all metal parts.
2. Inspect the interior and exterior of all metal parts that will be reused for severe corrosion, pitting and cracks. Superficial corrosion and or pitting on the exterior portion of the upper and lower body halves is acceptable.
3. Inspect the bores of both the end cover and the purge valve housing for deep scuffing or gouges.
4. Make certain that all purge valve housing and end cover passages are open and free of obstructions.
5. Inspect the pipe threads in the end cover. Make certain they are clean and free of thread sealant.
6. Inspect the purge valve housing bore and seats for excessive wear and scuffing.
7. Inspect the purge valve piston seat for excessive wear.

8. Inspect all air line fittings for corrosion. Clean all old thread sealant from the pipe threads.
9. All o-rings removed should be discarded and replaced with new o-rings provided in appropriate kit(s).

Any component exhibiting a condition described in step 1 to 8 should be replaced.

ASSEMBLY

Prior to assembly, coat all o-rings, o-ring grooves, and bores with a generous amount of barium base lubricant. Refer to Figure 7 during assembly unless otherwise advised.

1. Purge Valve Housing Assembly

A. Install the o-ring (14) in its groove on the O.D. of the purge piston. Place the return spring (13) in the bore of the purge valve housing. Place the o-ring (10) into its recess in the bore of the purge piston. Install the 1/4" Torx head bolt (31) into the I.D. of the purge piston. Insert the purge piston (33) into the I.D. of the spring (13). Using a Torx head wrench, push the purge piston into the piston housing until it bottoms.

B. While depressing the purge piston with the Torx head wrench, install the following parts over the purge valve bolt (31) from the opposite end of the purge valve housing; the purge valve (11) with its rubber side first, followed by the diaphragm (2) (if present), the diaphragm washer (32) (if present) or the flat washer and finally the 1/4" hex nut (4). Torque the purge valve nut and bolt (4 & 31) to between 60-80 in. lbs.

C. Install the three o-rings (5, 6 & 7) on the purge valve housing placing each in its appropriate location. If the exhaust cover (30) was removed during disassembly, install it on the purge valve housing assembly making certain the "bubble" portion is positioned over the thermostat. Install the assembled purge valve housing in the end cover making certain to orient both parts such that the connector is approximately 10 degrees clockwise from the supply port, while making certain the purge valve housing is fully seated against the end cover. Secure the purge valve housing to the end cover using the three 1/4" self-tapping screws (3). Start all three screws by hand then torque to 50-80 in. lbs.

2. Install the o-ring on the check valve assembly (15), then install the assembly in the end cover.
3. Install the desiccant cartridge o-ring (21) in its groove in the end cover. Using a light coat of barium grease, lubricate the bottom of the desiccant cartridge in the area that will contact the o-ring (21) and end cover.

Screw the desiccant cartridge into the end cover until contact is made between it and the o-ring. Using a strap or chain wrench positioned 2-3" from the bottom of the cartridge, turn the desiccant cartridge clockwise 180-225 degrees beyond the position where initial contact was made between the cartridge and end cover o-ring. Torque should not exceed 50 ft. lbs.

4. Install the end cover outer housing o-ring (23) on the shoulder in the end cover. Place the housing (24) over the desiccant cartridge and align the holes. Install the six 3/8" cap screws (16), lock nuts (19) and twelve special washers (17) making certain they are in the proper position as marked during disassembly. The two longer 3/8" cap screws (18) will be used to secure the AD-9 to its mounting bracket. Tighten the six cap screws and nuts in a star pattern in a fashion similar to Figure 8; depending on lower bracket location. Torque to 270-385 in. lbs. (Refer to Fig. 8.) **Note:** The two remaining bolt holes in the end cover and two 3/8" cap screws must be the ones marked during disassembly to assure proper orientation of the ports and adequate length of the cap screws.

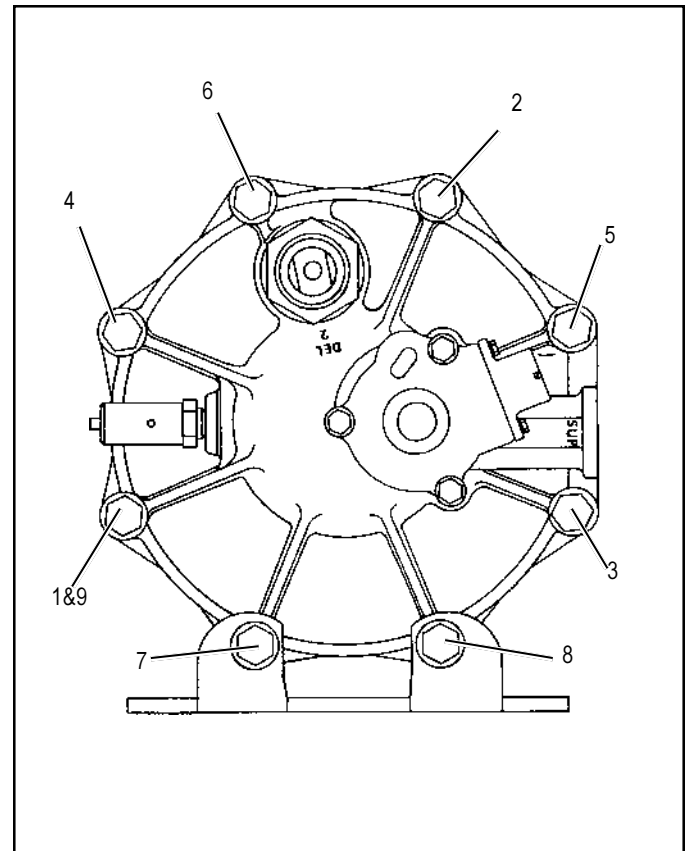

FIGURE 8 - END COVER TO HOUSING TORQUE PATTERN INSTALLATION

1. Install the assembled AD-9 air dryer back onto the vehicle by slipping it into the upper mounting bracket. Align the two unused holes in the end cover with the bottom mounting bracket such that the bottom bracket

supports air dryer. The AD-9 end cover should rest on the bracket. Using the remaining two 3/8" cap screws (18), four special washers (17), and two lock nuts (19), secure the air dryer to the lower bracket. Tighten, then torque the two remaining cap screws to 270-385 in. lbs.

2. Tighten the 5/16" X 4-1/2" bolt and nut on the upper mounting bracket. Torque to 80-120 in lbs.
3. Reconnect the three airlines to the proper ports on the end cover (identified during disassembly).
4. Reconnect the vehicle wiring harness to the AD-9 heater and thermostat assembly connector by plugging it into the air dryer connector until its lock tab snaps in place.
5. Before placing vehicle back into service, perform the *Operation and Leakage Tests* stated elsewhere in this manual.

RETROFITTING THE AD-9 AIR DRYER

GENERAL

The following retrofit instructions are presented for reference purposes only since Bendix aftermarket retrofit and replacement air dryers are packaged with the most up-to-date installation instructions. The instructions packaged with the AD-9 should be followed in lieu of those presented here.

The preceding portion of this manual deals with "in-service" repair and or replacement of the AD-9 air dryer. The portion of the manual that follows is concerned with installing an AD-9 on a vehicle not previously equipped with one.

VEHICLE APPLICATION REQUIREMENTS

The basic application requirements presented here apply to a standard air dryer installation. The majority of highway vehicles in use today will meet these basic requirements however, some may not. Examples of vehicles that may not meet the requirements include, bulk trailer unloading operations and other high air consumption/continuous flow systems. While the AD-9 air dryer can be used on these vehicles the standard installation procedure presented in this manual may require modification to assure proper operation and service life. Consult your local authorized Bendix parts outlet or sales representative for additional information.

1. Charge Cycle Time - The AD-9 air dryer is designed to provide clean, dry air for the brake system. When a vehicle's air system is used to operate non-brake air accessories it is necessary to determine that during normal, daily operation the compressor should recover from governor "cut-in" to governor "cut-out" (usually 100 psi to 120 psi) in 90 seconds or less at engine

RPMs commensurate with the vehicle vocation. If the recovery time consistently exceeds this limit, it may be necessary to "bypass" the air accessory responsible for the high air usage. Consult your local authorized Bendix parts outlet or sales representative for additional information.

2. Purge Cycle Time - During normal vehicle operation, the air compressor **must remain unloaded for a minimum of 20 seconds for the standard AD-9 Air Dryer or 30 seconds for the Extended Purge model**. These minimum purge times are required to ensure complete regeneration of the desiccant material. If the purge time is occasionally shorter than the times specified, no permanent ill effect should be expected, however, if the purge time is consistently less than the minimum, an accessory by-pass system must be installed.
3. European Air Brake Systems - Brake systems that incorporate compressors without integral unloading mechanisms and/or utilize a compressor discharge line unloader valve have special AD-9 air dryer installation requirements. Consult your local authorized Bendix parts outlet or sales representative for additional information.
4. Air Compressor Size - Although the AD-9 air dryer can be used in conjunction with larger compressors, it was designed primarily for units rated for up to 17 CFM. It is recommended that when using the AD-9 air dryer with a compressor which has a rated displacement exceeding 17 CFM that an authorized Bendix parts outlet or Bendix marketing representative be contacted for assistance.
5. Holset "E or QE" Type Air Compressors - In order for the AD-9 to function properly when installed with the Holset Type "E or QE" compressor, several specialized Holset components are required. Consult your local authorized Holset parts outlet or sales representative for additional information.
6. Use of Standard or Extended Purge AD-9 - Use the following guidelines:

Total Vehicle Reservoir

Volume	Requirement
Less than 9,000 cu. in.	Standard AD-9
9,000 - 12,500 cu. in.	Extended Purge AD-9
Greater than 12,500 cu. in.	Contact Bendix Rep. or Bendix Engineering

VEHICLE PREPARATION

1. Park the vehicle on a level surface and prevent movement by means other than the brakes.
2. Drain all reservoirs to 0 p.s.i. (0 kPa).

LOCATING AD-9 ON VEHICLE

1. The AD-9 air dryer must be mounted vertically (purge exhaust toward road surface) outside the engine compartment in an area of air flow while the vehicle is in motion. The AD-9 must not be exposed to direct wheel splash (located behind axle mud flap is acceptable).
2. Locate the AD-9 air dryer as close to the first (supply) reservoir as possible.
3. Do not locate the AD-9 air dryer near heat producing components such as the vehicle exhaust and make certain adequate clearance from moving components (e.g. drive shaft, suspension, pitman arm, etc.) is provided.
4. Locate the AD-9 air dryer on vehicle so that a minimum of 11 inches (28 CM) clearance below the end cover is available to allow servicing. Alternatively, provide access to the bracket bolts so the unit may be removed for servicing.
5. When choosing the mounting location for the AD-9, note the discharge line length requirements stated under the heading *Connecting the Air Lines*, elsewhere in this instruction sheet.

Important Note: Under normal operating conditions, the maximum inlet air temperature for the AD-9 air dryer is 150 degrees Fahrenheit.

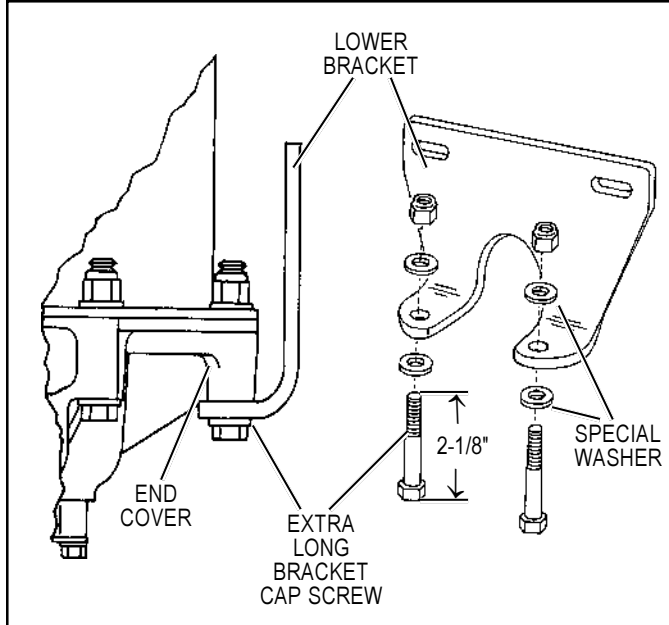

FIGURE 9 - LOWER BRACKET INSTALLATION

MOUNTING THE AD-9

1. To install the lower mounting bracket on the AD-9 air dryer, it will be necessary to remove and discard two of the end cover bolts and lock nuts. To determine which end cover bolts to utilize to attach the lower bracket, take into consideration the piping connections required

to install the AD-9 air dryer and use those that will best position the unit for ease of installation. Locate the bracket such that it cradles the end cover as shown in Figure 2. Utilizing the two 2-3/8" long cap screws, lock nuts and special washers provided with the AD-9 air dryer retrofit unit, attach the lower mounting bracket and torque to 270-385 in. lbs.

2. Assemble the mounting strap and upper mounting bracket as illustrated in Figure 4, by utilizing the 5/16" cap screw, 5/16" lockwasher and 5/16" nut provided.
3. Place the upper bracket assembly onto the shell of the AD-9 air dryer and orient it so that it bears entirely on the cylindrical surface and does not extend onto the domed top. The slot spacing between the upper and lower bracket should be a minimum of 5.5 inches apart. Do not tighten strap onto the shell at this time.
4. A universal mounting plate (Pc. No. 248478) is available to facilitate the mounting of the AD-9 air dryer to the vehicle. It can be obtained through an authorized Bendix parts outlet.
5. Mount the AD-9 air dryer on the vehicle using 3/8" bolts (grade 5 min.) and washers. Torque to 25 ft. lbs. (300 inch pounds.) After positioning and mounting the upper bracket assembly according to the installation requirements, torque the 5/16" nut to 80120 in. lbs. to tighten strap onto the shell.

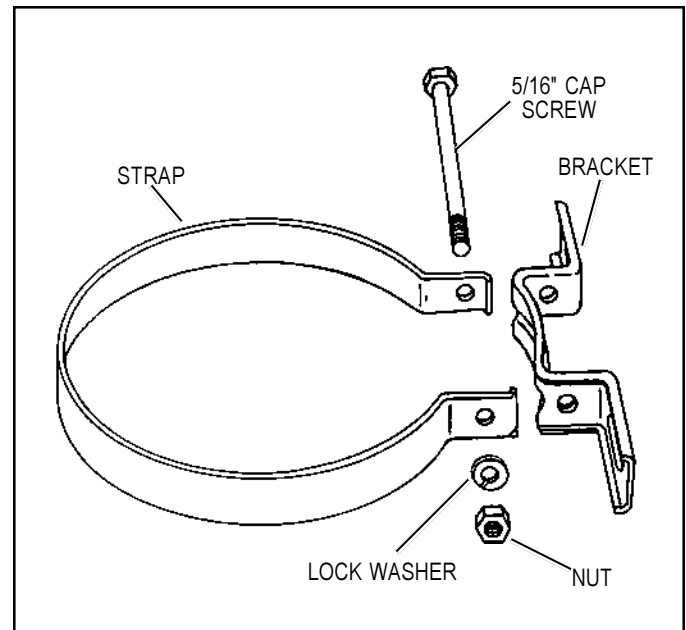

FIGURE 10 - UPPER MOUNTING BRACKET AND STRAP

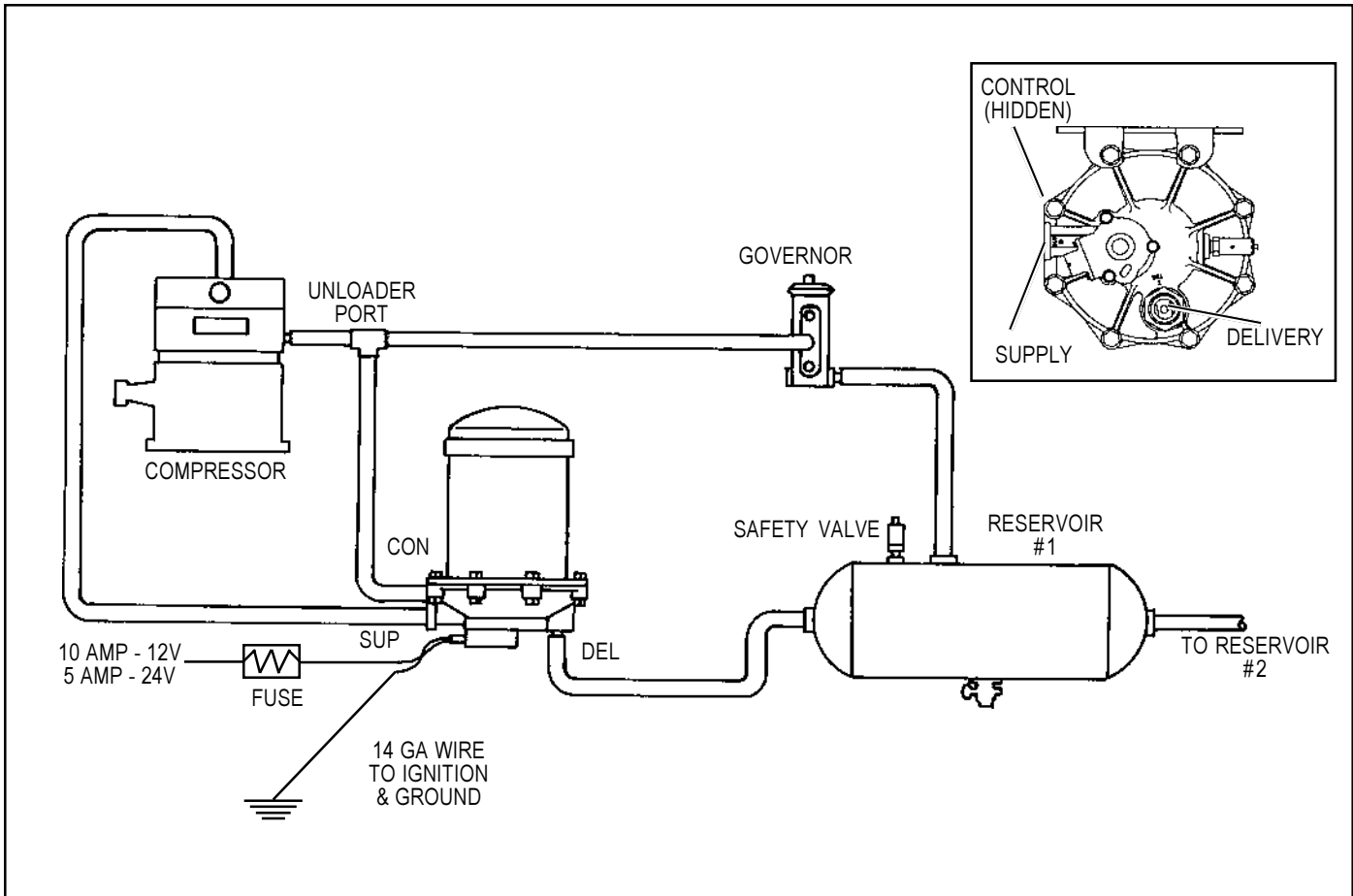

FIGURE 2 - AD-9 CHARGE CYCLE

CONNECTING THE AIR LINES

PURGE CONTROL LINE

1. Install a Purge Control air line having a minimum inside diameter of 3/16 inches between the AD-9 end cover control port and an unused unloader port on the governor. The control line must be plumbed direct to the governor and not in series with automatic drain valves, lubrication systems, etc.
2. The control line should slope downward to the end cover without forming potential water traps.

DISCHARGE LINE

General:

Where minimum diameter are specified, larger line diameters generally improve performance and life and reduce temperatures, particularly in severe applications.

1. The discharge line material should be wire braided "Teflon" hose, copper tubing or a combination of both.
2. The discharge line should slope downward from the compressor discharge port to the AD-9 air dryer supply port without forming water traps, kinks or restrictions. Cross-overs from one side of the frame

rail to the other, if required, should occur as close as possible to the compressor.

3. Fitting extensions must not be installed at the AD-9 supply port.
4. Discharge line lengths and inside diameter requirements are dependent on the vehicle application and are as follows:

Typical P&D, School Bus and Line Haul

The minimum discharge line length is 6 feet and the maximum is 16 feet.

LENGTH	I.D. MIN.	OTHER REQUIREMENTS
6.0 - 9.5 ft.	1/2 in.	None
9.5 - 12 ft.	1/2 in.	Last 3 feet including Supply Port fitting must be insulated with 1/2 inch thick closed cell polyethylene pipe insulation.
12 - 16 ft.	5/8 in.	Last 3 feet including Supply Port fitting must be insulated with 1/2 inch thick closed cell polyethylene pipe insulation.

If the discharge line length must be less than 6 feet or greater than 16 feet, contact your local Bendix representative or authorized parts outlet for further information.

High Duty Cycle Vehicles (City Transit Coaches, Refuse Haulers, etc.)

The minimum discharge line length is 10 feet and the maximum is 16 feet.

LENGTH	I.D. MIN.	OTHER REQUIREMENTS
10-16 ft.	1/2 in.	None

If the discharge line length must be less than 10 feet or greater than 16 feet, contact your local Bendix representative or authorized parts outlet for further information.

DELIVERY LINE

1. Install an air line of the same approximate I.D. as the discharge line between the AD-9 air dryer delivery port and the first (supply) reservoir. This line should also slope downward to the reservoir, if possible.

EXHAUST LINE

1. If it is necessary to direct AD-9 air dryer discharge contaminants away from vehicle components it may be necessary to purchase a special exhaust cover for the AD-9 air dryer (Pc. No. 298924) to replace the standard exhaust cover furnished with the unit. A 1 inch (25.4 mm) I.D. hose can be clamped on the special AD-9 air dryer exhaust cover. **Note:** Use a thin flat blade to pry the standard exhaust cover off.

WIRING THE HEATER/THERMOSTAT

1. Determine the vehicle's electrical system voltage and make certain that the AD-9 air dryer that is to be installed contains the same voltage heater. Use the AD-9 air dryer part number to confirm the proper voltage. The AD-9 air dryer is available with either a 12 or 24 volt heater which uses 75 watts of power.
2. A two lead, 12 inch, wire harness with attached weather resistant connector is supplied with all retrofit and replacement AD-9 air dryers. Connect one of the two leads of the wire harness to the engine kill or ignition switch. The remaining lead of the wire harness must be connected to a good vehicle ground (not to the air

dryer or its mounting bracket). A fuse should be installed in the power carrying wire; install a 10 amp fuse for 12 volt heaters and a 5 amp fuse for a 24 volt heater.

3. Use 14 GA wire if it is necessary to lengthen the wire harness provided with the AD-9 air dryer. Make certain all wire splices are waterproofed.
4. Tie wrap or support all electrical wire leading to the AD-9 air dryer at 6 - 8 inch intervals. **Note:** Wires should have sufficient slack and not completely taught.

TESTING THE AD-9

Before placing the vehicle in service, perform the following tests:

1. Close all reservoir drain cocks.
2. Build up system pressure to governor cut-out and note that the AD-9 air dryer purges with an audible escape of air.
3. "Fan" the service brakes to reduce system air pressure to governor cut-in. Note that the system once again builds to full pressure and is followed by a purge at the AD-9 air dryer exhaust.
4. It is recommended that the following items be tested for leakage to assure that the AD-9 air dryer will not cycle excessively.
 - (A) Total air system leakage (See Bendix publication BW-5057 "Air Brake Handbook").
 - (B) Compressor unloader mechanism.
 - (C) Governor.
 - (D) Drain cock and safety valve in first (supply) reservoir.
 - (E) All air connections leading to and from the first (supply) reservoir.

AD-9 AIR DRYER TROUBLESHOOTING CHART

SYMPTOMS	CAUSE	REMEDY
1. Dryer is constantly "cycling" or purging.	A. Excessive system leakage.	A. Test for excessive system leakage. Allowable leakage: Pre-121 vehicles, single vehicles - 2 psi/minute. Tractor trailer - 3 psi/minute. 121 vehicles, single vehicle - 1 psi/minute per service reservoir. Tractor trailer - 3 psi/minute per service reservoir.
	B. Excessive leakage in fitting, hoses and tubing connected to the compressor, air dryer and first reservoir.	B. Using soap solution, test for leakage at fittings, drain valve (if any) and safety valve in first reservoir. Repair or replace as necessary.
	C. Defective check valve assembly in AD-9 air dryer end cover.	C. Remove check valve assembly from end cover. Subject air pressure to delivery side of valve. Apply soap solution at opposite end and check for leakage. (Permissible leakage - 1 inch bubble in five seconds) If excessive leakage, replace check valve assembly.
	D. Defective governor.	D. Test governor for proper cut-in and cut-out pressures and excessive leakage in both positions.
	E. Leaking purge valve housing assembly and/or o-rings in AD-9 air dryer end cover.	E. With the supply port open to atmosphere, apply 120 psi at the control port. Apply a soap solution to the supply port and exhaust port (purge valve seat area). Permissible leakage - 1 inch bubble in five seconds.
	F. Compressor unloader mechanism leaking excessively.	F. Remove air strainer or fitting from compressor inlet cavity. With compressor unloaded, check for unloader piston leakage. Slight leakage permissible.
	G. Holset "E" type compressor.	G. Test Air Dryer system using Bendix Product Bulletin PRO-08-19 entitled "Troubleshooting The Holset E compressor system With Bendix Air Dryer."
	H. Rapid cycling of the governor due to air starvation at the RES port of the governor.	H. With gauge installed at RES port of governor, pressure should not drop below "Cut-In" pressure at the onset of the compressor "Unloaded" cycle. If pressure drops, check for "kinks" or restrictions in line connected to RES port. Line connected to RES port on governor must be same diameter, or preferably larger than, lines connected to UNL port(s) on governor.

AD-9 AIR DRYER TROUBLESHOOTING CHART (Continued)

SYMPTOMS	CAUSE	REMEDY
2. Water in vehicle reservoir.	A. Desiccant requires replacement - excessive contaminants in desiccant cartridge assembly.	A. Replace desiccant cartridge.
	B. Improper discharge line length or improper line material. Maximum air dryer inlet temperature is exceeded.	B. Refer to section entitled "Connecting the Air Lines" and check "Discharge Line" size and length.
	C. Air system charged from outside air source (outside air not passing through air dryer).	C. If system must have outside air fill provision, outside air should pass through air dryer. This practice should be minimized.
	D. Air dryer not purging (see Symptom #5).	D. See cause and remedy for Symptom #5.
	E. Purge (air exhaust) time insufficient due to excessive system leakage (see causes for Symptom #1).	E. Check causes and remedies for Symptom #1.
	F. Excessive air usage - Air dryer/vehicle application requires additional purge volume. Air dryer not compatible with vehicle air system requirement (Improper air dryer/ vehicle application).	F. <u>Charge Cycle Time</u> - The AD-9 is designed to provide clean, dry air for the brake system. When a vehicle's air system is used to operate non-brake air accessories it is necessary to determine that during normal, daily operation the compressor should recover from governor "cut-in" to governor "cut-out" (usually 100 psi to 120 psi) in 90 seconds or less at engine RPM's commensurate with the vehicle vocation. If the recovery time consistently exceeds this limit, it may be necessary to "bypass" the air accessory responsible for the high air usage. An example of where a by-pass system would be required is when the compressor is used to pressurize a tank trailer for purposes of off-loading product. Consult your local authorized Bendix parts outlet or sales representative for additional information. <u>Purge Cycle Time</u> - During normal vehicle operation, the air compressor must remain unloaded for a minimum of 20 seconds for the standard AD-9 or 30 seconds for the Extended Purge Model . These minimum purge times are required to ensure complete regeneration of the desiccant material. If the purge time is consistently less than the minimum, an accessory by-pass system must

AD-9 AIR DRYER TROUBLESHOOTING CHART (Continued)

SYMPTOMS	CAUSE	REMEDY
2. Water in vehicle reservoir (continued).		<p>be installed. Consult your local authorized Bendix parts outlet or sales representative for additional information.</p> <p><u>European Air Brake Systems</u> - Brake systems that incorporate compressors without integral unloading mechanisms and/or utilize a compressor discharge line unloader valve have special air dryer installation requirements. Consult your local authorized Bendix parts outlet or sales representative for additional information.</p> <p><u>Air Compressor Size</u> - Although the AD-9 can be used in conjunction with larger compressors, it was designed primarily for units rated for up to 17 CFM. It is recommended that when using the AD-9 with a compressor which has a rated displacement exceeding 17 CFM that an authorized Bendix parts outlet or Bendix marketing representative be contacted for assistance.</p>
	G. Air by-passes desiccant cartridge assembly.	G. Replace desiccant cartridge/end cover/o-ring. Check to make sure desiccant cartridge assembly is properly installed.
	H. Purge time is significantly less than minimum allowable.	H. Replace desiccant cartridge/end cover o-ring. Check to make sure desiccant cartridge assembly is properly installed. Replace desiccant cartridge assembly.
3. Safety valve on air dryer "popping off" or exhausting air.	A. Desiccant cartridge plugged.	A. Check compressor for excessive oil passing and/or correct compressor installation. Repair or replace as necessary. Rebuild or replace cartridge.
	B. Defective discharge check valve in end cover of the AD-9.	B. Test to determine if air is passing through check valve. Repair or replace.
	C. Defective fittings, hose or tubing between air dryer and first reservoir.	C. Check to determine if air is reaching first reservoir. Inspect for kinked tubing or hose. Check for undrilled or restricted hose or tubing fittings.
	D. Excessive pressure pulsations from compressor. (Typical single cylinder type).	D. Increase volume in discharge line. Added length or size of line, or add a ping tank.
	E. Safety valve setting lower than the maximum system pressure.	E. Reduce system pressure or obtain a higher setting safety valve.

AD-9 AIR DRYER TROUBLESHOOTING CHART (Continued)

SYMPTOMS	CAUSE	REMEDY
<p>4. Constant exhaust of air at air dryer purge valve exhaust or unable to build system pressure. (Charge mode.)</p>	A. Air dryer purge valve leaking excessively.	A. With compressor loaded, apply soap solution on purge valve exhaust, to test for excessive leakage. Repair purge valve as necessary.
	B. Defective governor.	B. Check governor for proper "cut-in", "cut-out" pressure and excessive leakage in both positions. Repair or replace as necessary.
	C. Purge control line connected to reservoir or exhaust port of governor.	C. Purge control line must be connected to unloader port of governor.
	D. Purge valve frozen open - faulty heater and thermostat, wiring, blown fuse.	D. Test heater and thermostat as described in Step 7 of <i>Preventative Maintenance</i> Section.
	E. Inlet and outlet air connections reversed.	E. Compressor discharge to inlet port. Reconnect lines properly.
	F. Kinked or blocked (plugged) discharge line.	F. Check to determine if air passes through discharge line. Check for kinks, bends, excessive carbon deposits.
	G. Excessive bends in discharge line (water collects and freezes).	G. Discharge line should be constantly sloping from compressor to air dryer with as few bends as possible.
	H. Excessive system leakage.	H. See Symptom #1's Causes and Remedies.
	I. Purge valve stays open - supply air leaks to control side.	I. Replace purge valve housing assembly o-rings.
<p>5. Air dryer does not purge or exhaust air.</p>	A. Broken, kinked, frozen, plugged or disconnected purge control line.	A. Test to determine air flows through purge control line when compressor unloaded. Check for undrilled fittings. (See Symptom #4, Remedy C.)
	B. See Causes B, E, G for Symptom #4.	B. Refer to Remedies B, E, G for Symptom #4.
<p>6. Desiccant material being expelled from air dryer purge valve exhaust (may look like whitish liquid or paste or small beads.)</p> <p style="text-align: center;">- OR -</p> <p>Unsatisfactory desiccant life.</p>	A. This symptom is almost always accompanied by one or more of Symptoms 1, 2, 3, 4 and 5. See related causes for these Symptoms above.	A. See Causes and Remedies for Symptoms 1, 2, 3, 4 and 5.
	B. Air dryer not securely mounted. (Excessive vibration.)	B. Vibration should be held to minimum. Add bracket supports or change air dryer mounting location if necessary.
	C. Defective cloth covered perforated plate in air dryer.	C. Replace desiccant cartridge assembly.

AD-9 AIR DRYER TROUBLESHOOTING CHART (Continued)

SYMPTOMS	CAUSE	REMEDY
6. (Continued.)	D. Compressor passing excessive oil.	D. Check for proper compressor installation; if symptoms persist, replace compressor.
	E. Desiccant cartridge not assembled properly to end cover. (Loose attachment)	E. Check the torque on the desiccant cartridge to end cover attachment. Refer to assembly section of this data sheet.
7. "Pinging" noise excessive during compressor loaded cycle.	A. Single cylinder compressor with high pulse cycles.	A. A slight "pinging" sound may be heard during system build up when a single cylinder compressor is used. If this sound is deemed objectionable, it can be reduced substantially by increasing the discharge line volume. This can be accomplished by adding an additional four feet of discharge line or adding a 90 cubic inch reservoir between the compressor and the AD-9 air dryer.
8. Constant seepage of air at air dryer purge valve exhaust (non-charging mode.)	A. Inlet of air compressor pressurized by turbocharger from engine.	A. Some leakage of pressure past the metal seat of the turbo cutoff feature of the AD-9 is to be expected also may be audible. This slight loss of air will not effect the engine or turbo performance.
	B. Defective check valve assembly in AD-9 air dryer end cover.	B. Refer to Remedy C, Symptom #1.
9. The air dryer purge piston cycles rapidly in the compressor unloaded (noncompressing) mode.	A. Compressor fails to "unload".	A. Faulty governor installation; no air line from governor to compressor or line is "kinked" or restricted. Install or repair air line.

