

Troubleshooting Manual

Allison Transmission

WORLD TRANSMISSION

WTEC III Controls (TransID 1 and 2)

MD 3060/MD 3066/MD 3560(P)(R)

MD 3070PT

HD 4060/HD 4560(P)(R)

B 300/B 400/B 500(P)(R)

May, 1998



Allison Transmission

Division of General Motors Corporation
P.O. Box 894 Indianapolis, Indiana 46206-0894

FOREWORD — How to Use This Manual

This manual provides troubleshooting information for Allison Transmission Division, World Transmissions. Service Manuals SA2148, SA2468, SA2457, and Parts Catalogs SA2150, SA3050, SA2467, SA2922, and SA2456, may be used in conjunction with this manual.

This manual includes:

- Description of the WTEC III electronic control system.
- Description of the electronic control system components.
- Description of diagnostic codes, system responses to faults, and troubleshooting.
- Wire, terminal, and connector repair information.

Specific instructions for using many of the available or required service tools and equipment are not included in this manual. The service tool manufacturer will furnish instructions for using the tools or equipment.

Additional information may be published from time to time in Service Information Letters (SIL) and will be included in future revisions of this and other manuals. Please use these SILs to obtain up-to-date information concerning Allison Transmission products.

This publication is revised periodically to include improvements, new models, special tools, and procedures. A revision is indicated by a letter suffix added to the publication number. Check with your Allison Transmission service outlet for the currently applicable publication. Additional copies of this publication may be purchased from authorized Allison Transmission service outlets. Look in your telephone directory under the heading of Transmissions — Truck, Tractor, etc.

Take time to review the Table of Contents and the manual. Reviewing the Table of Contents will aid you in quickly locating information.

NOTE: *Allison Transmission is providing for service of wiring harnesses and wiring harness components as follows:*

- Repair parts for the internal wiring harness and for wiring harness components attached to the shift selector will be available through the Allison Transmission Parts Distribution Center (PDC). Use the P/N from your appropriate parts catalog or from Appendix E in this manual. Allison Transmission is responsible for warranty on these parts.
- Repair parts for the external harnesses and external harness components must be obtained from St. Clair Technologies Inc. (SCTI). SCTI provides parts to any Allison customer or OEM and is responsible for warranty on these parts. SCTI recognizes ATD, manufacturers, and SCTI part numbers. SCTI provides a technical HELPLINE at 519-627-1673 (Wallaceburg). SCTI will have parts catalogs available. The SCTI addresses and phone numbers for parts outlets are:

St. Clair Technologies, Inc.
1050 Old Glass Road
Wallaceburg, Ontario, Canada, N8A 3T2
Phone: (519) 627-1673
Fax: (519) 627-4227

St. Clair Technologies, Inc.
1111 Mikesell Street
Charlotte, Michigan 48813
Phone: (517) 541-8166
Fax: (517) 541-8167

St. Clair Technologies, Inc.
c/o Mequilas Tetakawi
Carr. Internationale KM 1969
Guadalajara – Nogales, KM2
Empalme, Sonora, Mexico
Phone: 011-52-622-34661
Fax: 011-52-622-34662

- The Allison Transmission PDC will stock a WTEC III external harness repair kit, P/N 29532362, as an interim parts source for some external harness repair parts. SCTI will have a more complete stock and should be considered the prime source for external harness repair parts.

IMPORTANT SAFETY NOTICE

IT IS YOUR RESPONSIBILITY to be completely familiar with the warnings and cautions used in this manual. These warnings and cautions advise against using specific service procedures that can result in personal injury, equipment damage, or cause the equipment to become unsafe. These warnings and cautions are not exhaustive. Allison Transmission could not possibly know, evaluate, or advise the service trade of all conceivable procedures by which service might be performed or of the possible hazardous consequences of each procedure. Consequently, Allison Transmission has not undertaken any such broad evaluation. Accordingly, **ANYONE WHO USES A SERVICE PROCEDURE OR TOOL WHICH IS NOT RECOMMENDED BY ALLISON TRANSMISSION MUST** first be thoroughly satisfied that neither personal safety nor equipment safety will be jeopardized by the service procedures used.

Also, be sure to review and observe **WARNINGS, CAUTIONS, and NOTES** provided by the vehicle manufacturer and/or body builder before servicing the Allison transmission in that vehicle.

Proper service and repair is important to the safe and reliable operation of the equipment. The service procedures recommended by Allison Transmission and described in this manual are effective methods for performing troubleshooting operations. Some procedures require using specially designed tools. Use special tools when and in the manner recommended.

The **WARNINGS, CAUTIONS, and NOTES** in this manual apply only to the Allison transmission and not to other vehicle systems which may interact with the transmission. Be sure to review and observe any vehicle system information provided by the vehicle manufacturer and/or body builder at all times the Allison transmission is being serviced.

WARNINGS, CAUTIONS, AND NOTES

Three types of headings are used in this manual to attract your attention:

WARNING!

Is used when an operating procedure, practice, etc., which, if not correctly followed, could result in injury or loss of life.

CAUTION:

Is used when an operating procedure, practice, etc., which, if not strictly observed, could result in damage to or destruction of equipment.

NOTE: *Is used when an operating procedure, practice, etc., is essential to highlight.*

TRADEMARKS USED IN THIS MANUAL

The following trademarks are the property of the companies indicated:

- LPS® Cleaner is a registered trademark of LPS Laboratories.
- Loctite® is a registered trademark of the Loctite Corporation.
- Teflon® is a registered trademark of the DuPont Corporation.
- Pro-Link® is a registered trademark of MicroProcessor Systems, Inc.

SHIFT SELECTOR TERMS AND DISPLAY INDICATIONS

Shift selector terms and displays are represented in this manual as follows:

- Button Names — \uparrow , \downarrow , “display mode”, **MODE**, etc.
- Transmission Ranges — **D** (Drive), **N** (Neutral), **R** (Reverse), **1** (First), **2** (Second), etc.
- Displays — “**o**, **L**”; “**o**, **K**”, etc. (Display occurs one character at a time.)

TABLE OF CONTENTS

Page

Foreword ii

SAFETY INFORMATION

Important Safety Notice iii

Warnings, Cautions, and Notes iii

Trademarks Used in This Manual iv

Shift Selector Terms and Display Indications iv

SECTION 1. GENERAL DESCRIPTION

1-1. TRANSMISSION 1-1

1-2. ELECTRONIC CONTROL UNIT (ECU) 1-3

1-3. SHIFT SELECTOR 1-3

 A. Pushbutton Shift Selector 1-3

 B. Lever Shift Selector 1-4

1-4. THROTTLE POSITION SENSOR 1-5

1-5. SPEED SENSORS 1-5

1-6. CONTROL MODULE 1-6

1-7. WIRING HARNESSES 1-7

 A. External Wiring Harness 1-7

 B. Internal Wiring Harness 1-9

1-8. VEHICLE INTERFACE MODULE 1-9

1-9. AUTODETECT FEATURE 1-10

 A. Retarder 1-10

 B. Oil Level Sensor 1-10

 C. Throttle Source 1-11

 D. Engine Coolant Temperature 1-11

1-10. TRANSID FEATURE 1-11

 A. General Description 1-11

 B. Transmission Changes Versus TransID Number 1-12

 C. Compatibility Between TransID Level and ECU Calibration Level 1-13

SECTION 2. DEFINITIONS AND ABBREVIATIONS

2-1. CHECK TRANS LIGHT 2-1

2-2. DIAGNOSTIC DATA READER 2-1

2-3. ABBREVIATIONS 2-2

TABLE OF CONTENTS *(cont'd)*

	Page
SECTION 3. BASIC KNOWLEDGE	
3-1. BASIC KNOWLEDGE REQUIRED	3-1
3-2. USING THE TROUBLESHOOTING MANUAL	3-2
3-3. SYSTEM OVERVIEW	3-2
3-4. IMPORTANT INFORMATION IN THE TROUBLESHOOTING PROCESS	3-2
3-5. BEGINNING THE TROUBLESHOOTING PROCESS	3-3
SECTION 4. WIRE CHECK PROCEDURES	
4-1. CHECKING OPENS, SHORTS BETWEEN WIRES, AND SHORTS-TO-GROUND	4-1
4-2. CHECKING AT TRANSMISSION CONNECTOR AND THE INTERNAL HARNESS FOR OPENS, SHORTS BETWEEN WIRES, AND SHORTS-TO-GROUND	4-2
SECTION 5. OIL LEVEL SENSOR	
5-1. ELECTRONIC FLUID LEVEL CHECK (SHIFT SELECTOR).....	5-1
A. Fluid Level Check Procedure.....	5-1
5-2. ELECTRONIC FLUID LEVEL CHECK (PRO-LINK® 9000).....	5-3
A. Fluid Level Check Procedure.....	5-3
SECTION 6. DIAGNOSTIC CODES	
6-1. DIAGNOSTIC CODE MEMORY	6-1
6-2. CODE READING AND CODE CLEARING	6-1
6-3. DIAGNOSTIC CODE RESPONSE	6-3
6-4. SHIFT SELECTOR DISPLAYS RELATED TO ACTIVE CODES	6-4
6-5. DIAGNOSTIC CODE LIST AND DESCRIPTION.....	6-4
6-6. DIAGNOSTIC CODE TROUBLESHOOTING.....	6-17
A. Beginning the Troubleshooting Process	6-17
B. Solenoid Locations	6-17
C. Diagnostic Code Schematics	6-17
D. Wire/Terminal Numbering Scheme	6-18
SECTION 7. INPUT AND OUTPUT FUNCTIONS	
7-1. INPUT FUNCTIONS	7-1
7-2. OUTPUT FUNCTIONS	7-3
SECTION 8. GENERAL TROUBLESHOOTING OF PERFORMANCE COMPLAINTS	

TABLE OF CONTENTS *(cont'd)*

Page

APPENDICES

A. IDENTIFICATION OF POTENTIAL CIRCUIT PROBLEMS	A-1
B. CHECKING CLUTCH PRESSURES	B-1
C. SOLENOID AND CLUTCH CHART	C-1
D. WIRE/CONNECTOR CHART.....	D-1
E. CONNECTOR PART NUMBERS, TERMINAL PART NUMBERS, TOOL PART NUMBERS, AND REPAIR INSTRUCTIONS	E-1
F. THROTTLE POSITION SENSOR ADJUSTMENT	F-1
G. WELDING ON VEHICLE/VEHICLE INTERFACE MODULE	G-1
H. HYDRAULIC SCHEMATICS	H-1
J. WT WIRING SCHEMATIC.....	J-1
K. TRANSID 1 TEMPERATURE SENSOR AND SOLENOID RESISTANCE CHARTS.....	K-1
L. EXTERNALLY-GENERATED ELECTRONIC INTERFERENCE	L-1
M. DIAGNOSTIC TREE — WT SERIES HYDRAULIC SYSTEM	M-1
N. PRO-LINK® 9000 DIAGNOSTIC DATA READER INFORMATION.....	N-1
P. INPUT/OUTPUT FUNCTION WIRING SCHEMATICS.....	P-1
Q. TRANSID 2 THERMISTOR TROUBLESHOOTING INFORMATION	Q-1

NOTES

SECTION 1 — GENERAL DESCRIPTION

1-1. TRANSMISSION

The World Transmission Electronic Controls (WTEC III) system features closed-loop clutch control to provide superior shift quality over a wide range of operating conditions. MD 3000, HD 4000, and B Series configurations can be programmed to have up to six forward ranges, neutral, and one reverse range. The MD 3070 has seven forward ranges and one reverse range.

Figure 1-1 is a block diagram of the basic system inputs and outputs.

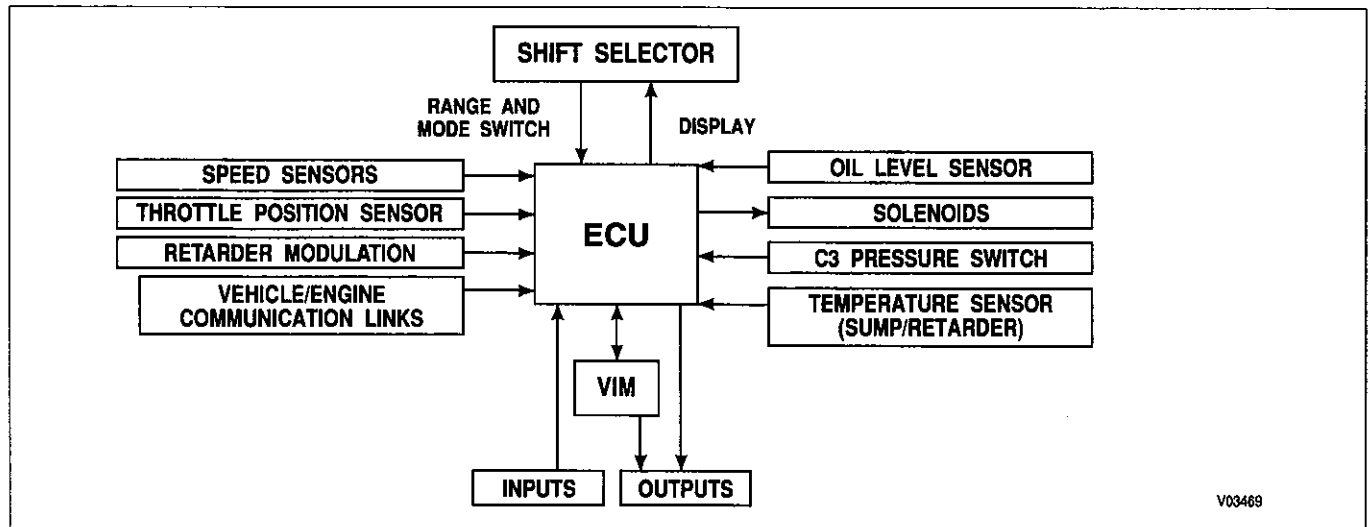

Figure 1-1. Electronic Control Unit Block Diagram

Figure 1-2 shows WTEC III electronic control components.

WTEC III Electronic Controls consist of the following elements:

- Remote 12/24V Max Feature Sealed Electronic Control Unit (ECU)
- Remote Pushbutton or Lever Shift Selector
- Optional Secondary Shift Selector
- Throttle Position Sensor (TPS) (or electronic engine throttle data or PWM signal)
- Engine, Turbine, and Output Speed Sensors
- Control Module (Electro-Hydraulic Valve Body)
- Wiring Harnesses
- Vehicle Interface Module (VIM)
- Autodetect Feature
- TransID Feature
- Optional Retarder Controls
- Optional Engine Coolant Temperature Input

NOTE:

- All external harnesses are OEM supplied
- Some OEMs may supply their own shift selector
- The VIM is an OEM option

GENERAL DESCRIPTION

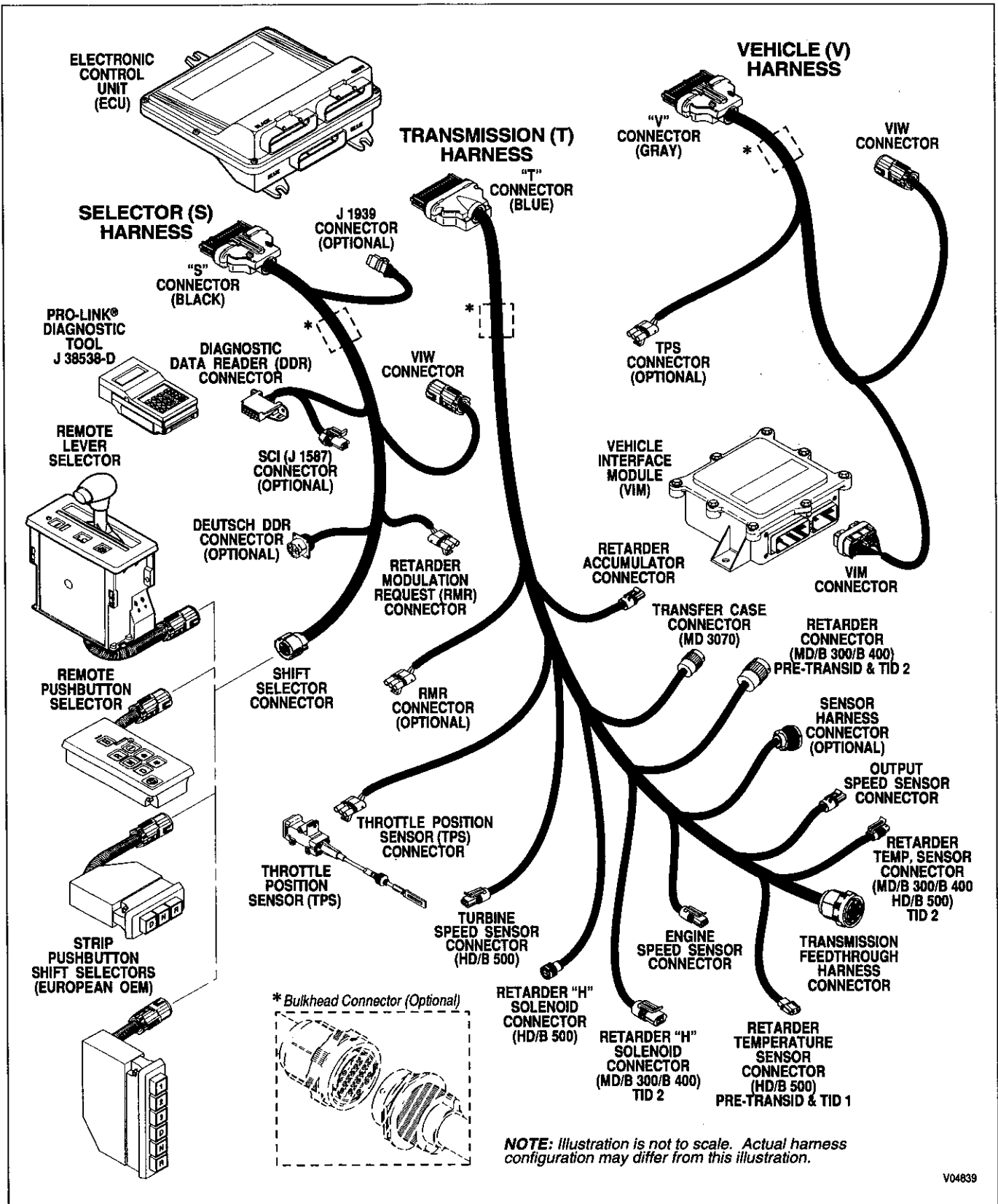

V04639

Figure 1-2. WTEC III Electronic Control Components

GENERAL DESCRIPTION

1-2. ELECTRONIC CONTROL UNIT (ECU)

The ECU (Figure 1-3) contains the microcomputer which is the brain of the control system. The ECU receives and processes information defining: shift selector position, throttle position, sump/retarder temperature, engine speed, turbine speed, and transmission output speed. The ECU uses the information to control transmission solenoids and valves, supply system status, and provide diagnostic information.

Each ECU has a date code stamped on the label which is attached to the outer case of the ECU. This is the date when the ECU passed final test. This date is commonly used to denote the change configuration level of the ECU. It is normal for the ECU date displayed electronically to be a few days prior to the date shown on the label.

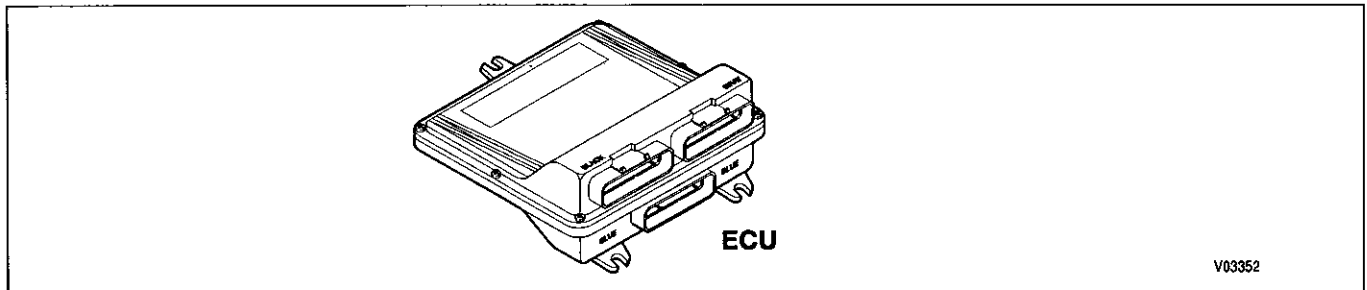

Figure 1-3. Electronic Control Unit (ECU)

1-3. SHIFT SELECTOR

Pushbutton and lever shift selectors for the WTEC III Series are remote mounted from the ECU and connected to the ECU by a wiring harness. Both of these shift selectors have a single digit LED display and a mode indicator (LED). During normal transmission operation, illumination of the LED indicator shows that a secondary or special operating condition has been selected by pressing the **MODE** button. During diagnostic display mode, illumination of the LED indicator shows that the displayed diagnostic code is active. Display brightness is regulated by the same vehicle potentiometer that controls dash light display brightness. More information on both types of shift selectors is continued below.

A. Pushbutton Shift Selector (Figure 1-4)

There is a full-function pushbutton shift selector and a strip pushbutton shift selector. Strip pushbutton shift selectors are used by European OEMs. A full-function shift selector has a **MODE** button and diagnostic display capability through the single digit LED display. The strip pushbutton shift selector does not have a **MODE** button, diagnostic capability, or adjustable illumination. The full-function pushbutton shift selector has six (6) pushbuttons which are **R** (Reverse), **N** (Neutral), **D** (Drive), ↓ (Down), ↑ (Up), and **MODE**. Manual forward range downshifts and upshifts are made by pressing the ↓ (Down) or ↑ (Up) arrow buttons after selecting **D** (Drive). The **N** (Neutral) button has a raised lip to aid in finding it by touch. The **MODE** button is pressed to select a secondary or special operating condition, such as **ECONOMY** shift schedule. Diagnostic information is obtained by pressing the ↑ (Up) and ↓ (Down) arrow buttons at the same time. The strip pushbutton shift selector has either three or six range selection positions as shown in Figure 1-4. When a strip pushbutton shift selector is used, diagnostic information must be obtained by using the Pro-Link® 9000 or a customer-furnished remote display.

GENERAL DESCRIPTION

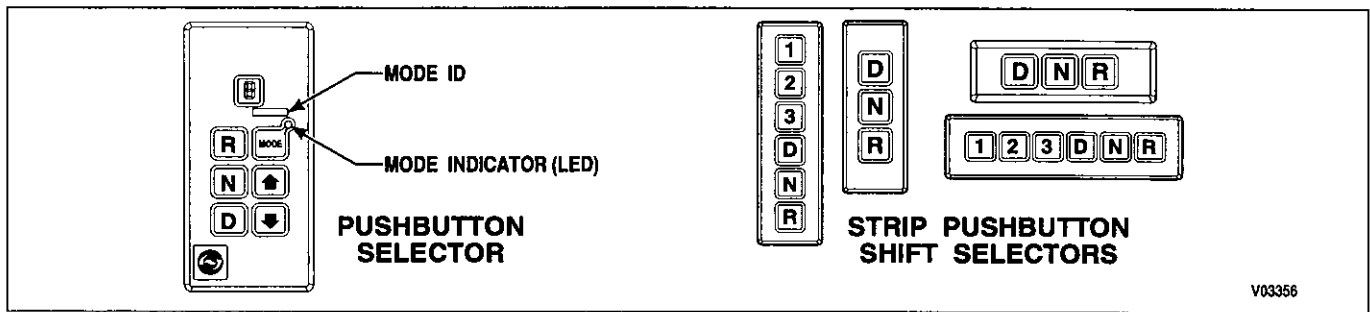

Figure 1-4. Pushbutton Shift Selectors

B. Lever Shift Selector (Figure 1-5)

The lever shift selector can have as many as six forward range positions (seven for the MD 3070PT), as well as **R** (Reverse) and **N** (Neutral). There is a hold override button which must be pressed and held in order to move between certain selector positions. The hold override button must be pressed when shifting between **R**, **N**, and **D**. The hold override button is released when the desired selector position is reached. The selector lever can be moved freely between **D** and the numbered forward ranges without pressing the hold override button. The lever selector can be chosen with the lever on the left side or on the right side and with the **R** (Reverse) position toward the front or toward the rear of the selector. Diagnostic and oil level (if sensor is present) information is obtained from the single digit LED display by pressing the “display mode” button.

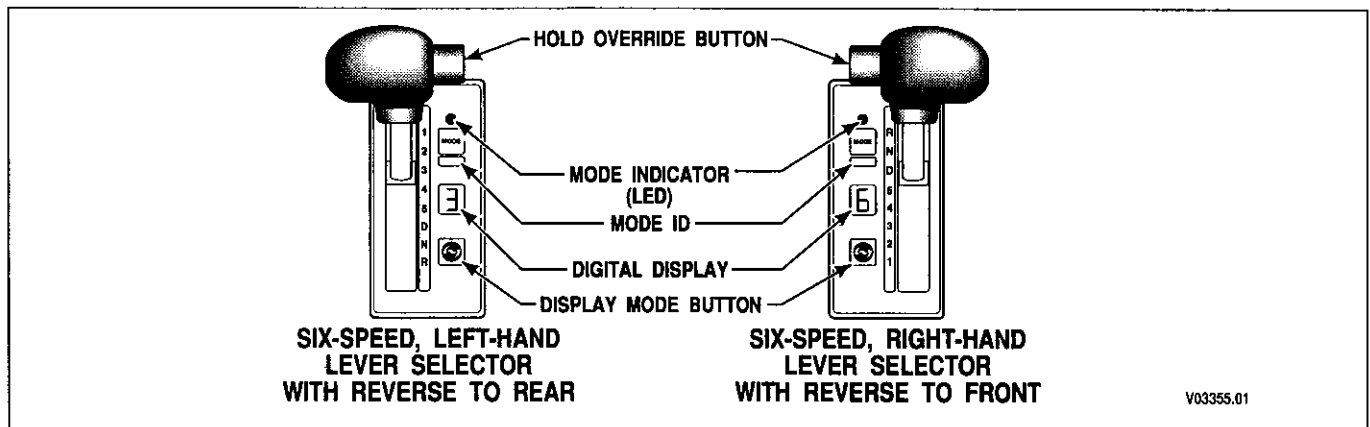

Figure 1-5. Typical Lever Shift Selector

GENERAL DESCRIPTION

1-4. THROTTLE POSITION SENSOR (Figure 1-6)

The Throttle Position Sensor (TPS) can be mounted to the engine, chassis, or transmission. The TPS contains a pull actuation cable and a potentiometer. One end of the cable is attached to the engine fuel lever and the other, inside a protective housing, to the TPS potentiometer. Output voltage from the TPS is directed to the ECU through the external harness. The voltage signal indicates the throttle position and, in combination with other input data, determines shift timing.

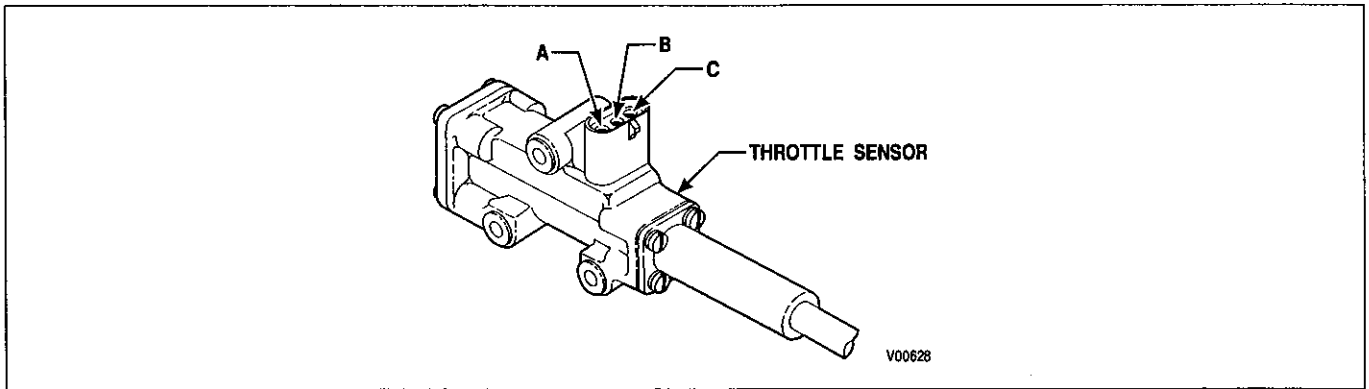

Figure 1-6. Throttle Position Sensor

1-5. SPEED SENSORS (Figure 1-7)

Three speed sensors — engine speed, turbine speed, and output speed — provide information to the ECU. The engine speed signal is generated by ribs on the shell of the torque converter pump. The turbine speed signal is generated by the rotating-clutch housing spline contours. The output speed signal is generated by a toothed member attached to the output shaft (except for the MD 3070, where the toothed member is the transfer case idler gear). The speed ratios between the various speed sensors allow the ECU to determine if the transmission is in the selected range. Speed sensor information is also used to control the timing of clutch apply pressures, resulting in the smoothest shifts possible. Hydraulic problems are detected by comparing the speed sensor information for the current range to that range's speed sensor information stored in the ECU memory.

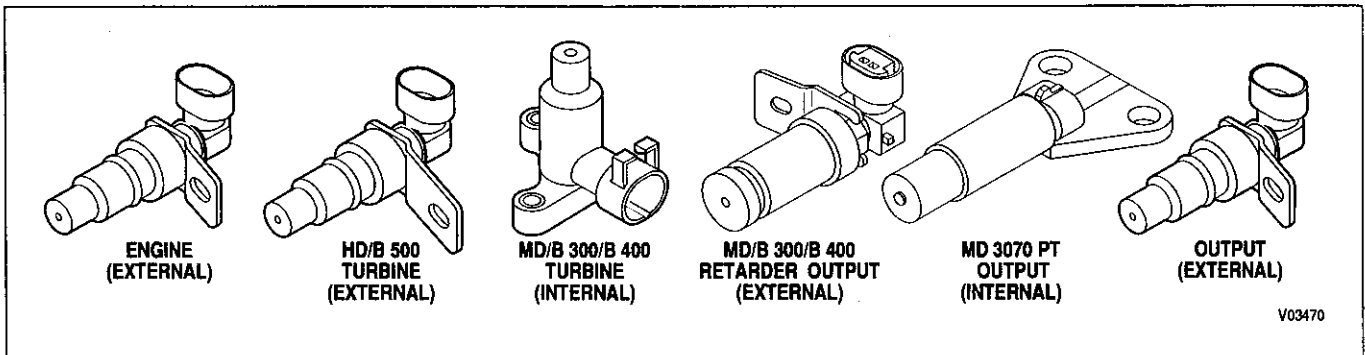

Figure 1-7. Speed Sensors

GENERAL DESCRIPTION

1-6. CONTROL MODULE (Figure 1-8)

The WT Series transmission control module contains a channel plate on which is mounted: the main valve body assembly, the stationary-clutch valve body assembly, and the rotating-clutch valve body assembly. For valve locations, refer to SIL 27-WT-93, Rev. A. Pulse width modulated solenoids are used in the valve bodies. The rotating-clutch valve body assembly contains A (C1), B (C2), and F (lockup) solenoids, solenoid regulator valves controlled by the solenoids, and the C3 pressure switch. The stationary-clutch valve body assembly contains C (C3), D (C4), and E (C5) solenoids and solenoid regulator valves controlled by the solenoids and the C3 accumulator relay valve. The main valve body assembly contains G solenoid and the C1 and C2 latch valves controlled by the solenoid, the main and lube regulator valves, the control main and converter regulator valves, and the converter flow valve and exhaust backfill valves. The low valve body assembly (MD 3070PT) contains N and J solenoids.

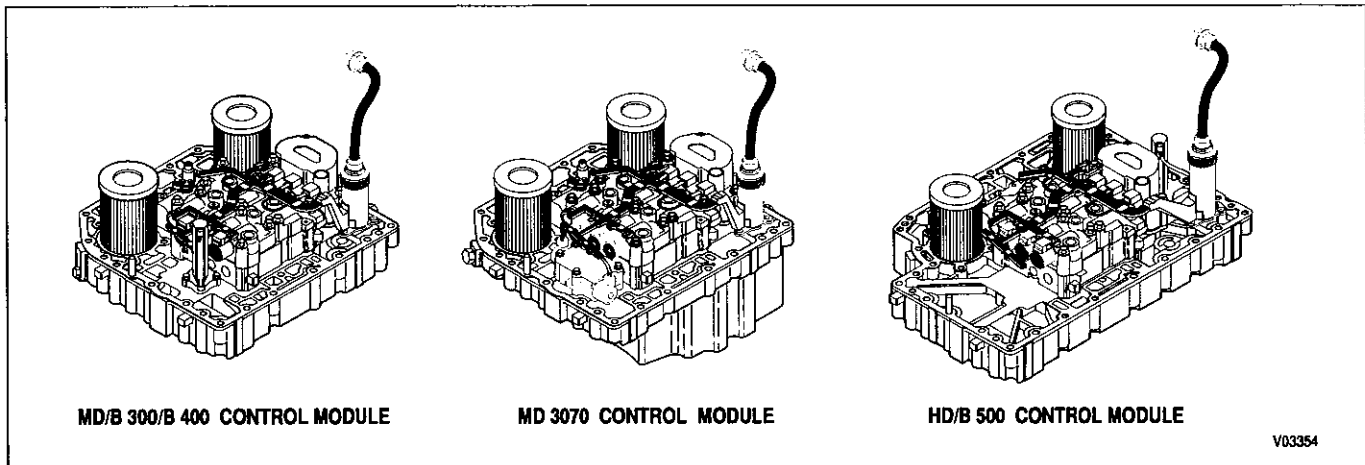

Figure 1-8. WTEC III Control Module

A temperature sensor (thermistor) is located in the internal wiring harness. Changes in sump fluid temperature are indicated by changes in sensor resistance which changes the signal sent to the ECU (see chart in Section 6, Code 24).

The oil level sensor is a float type device, mounted on the control module channel plate, which senses transmission fluid level by electronically measuring the buoyancy forces on the float. The sensor operates on 5 VDC supplied by the ECU. The oil level sensor is required on all models with a shallow sump but is optional on other models.

The C3 pressure switch is mounted on the rotating-clutch valve body assembly and indicates when pressure exists in the C3 clutch-apply passage. An accumulator/relay valve is in-line ahead of the C3 pressure switch and prevents high frequency hydraulic pulses generated by the C3 solenoid from cycling the C3 pressure switch.

Also mounted in the control module is the turbine speed sensor for the MD/B 300/B 400 models. The turbine speed sensor is directed at the rotating-clutch housing. (The turbine speed sensor on the HD/B 500 models is located on the outside of the main housing.)

GENERAL DESCRIPTION

1-7. WIRING HARNESES

A. External Wiring Harness (*Figure 1-9*)

WTEC III uses three external wiring harnesses to provide a connection between the ECU, the transmission (including engine, turbine, and output speed sensors), the throttle position sensor, the vehicle interface module (VIM), retarder control module, shift selectors, diagnostic tool connector, retarder, retarder temperature sensor, accumulator, and vehicle interface. Many harnesses will include a bulkhead fitting to separate cab and chassis components. Also, many different styles and materials for harnesses are likely to be encountered.

NOTE: *Allison Transmission is providing for service of wiring harnesses and wiring harness components as follows:*

- Repair parts for the internal wiring harness and for wiring harness components attached to the shift selector will be available through the Allison Transmission Parts Distribution Center (PDC). Use the P/N from your appropriate parts catalog or from Appendix E in this manual. Allison Transmission is responsible for warranty on these parts.
- Repair parts for the external harnesses and external harness components must be obtained from St. Clair Technologies Inc. (SCTI). SCTI provides parts to any Allison customer or OEM and is responsible for warranty on these parts. SCTI recognizes ATD, manufacturers, and SCTI part numbers. SCTI provides a technical HELPLINE at 519-627-1673 (Wallaceburg). SCTI will have parts catalogs available. The SCTI addresses and phone numbers for parts outlets are:

St. Clair Technologies, Inc.
1050 Old Glass Road
Wallaceburg, Ontario, Canada, N8A 3T2
Phone: (519) 627-1673
Fax: (519) 627-4227

St. Clair Technologies, Inc.
1111 Mikesell Street
Charlotte, Michigan 48813
Phone: (517) 541-8166
Fax: (517) 541-8167

St. Clair Technologies, Inc.
c/o Mequilas Tetakawi
Carr. Internationale KM 1969
Guadalajara – Nogales, KM2
Empalme, Sonora, Mexico
Phone: 011-52-622-34661
Fax: 011-52-622-34662

- The Allison Transmission PDC will stock a WTEC III external harness repair kit, P/N 29532362, as an interim parts source for some external harness repair parts. SCTI will have a more complete stock and should be considered the prime source for external harness repair parts.

GENERAL DESCRIPTION

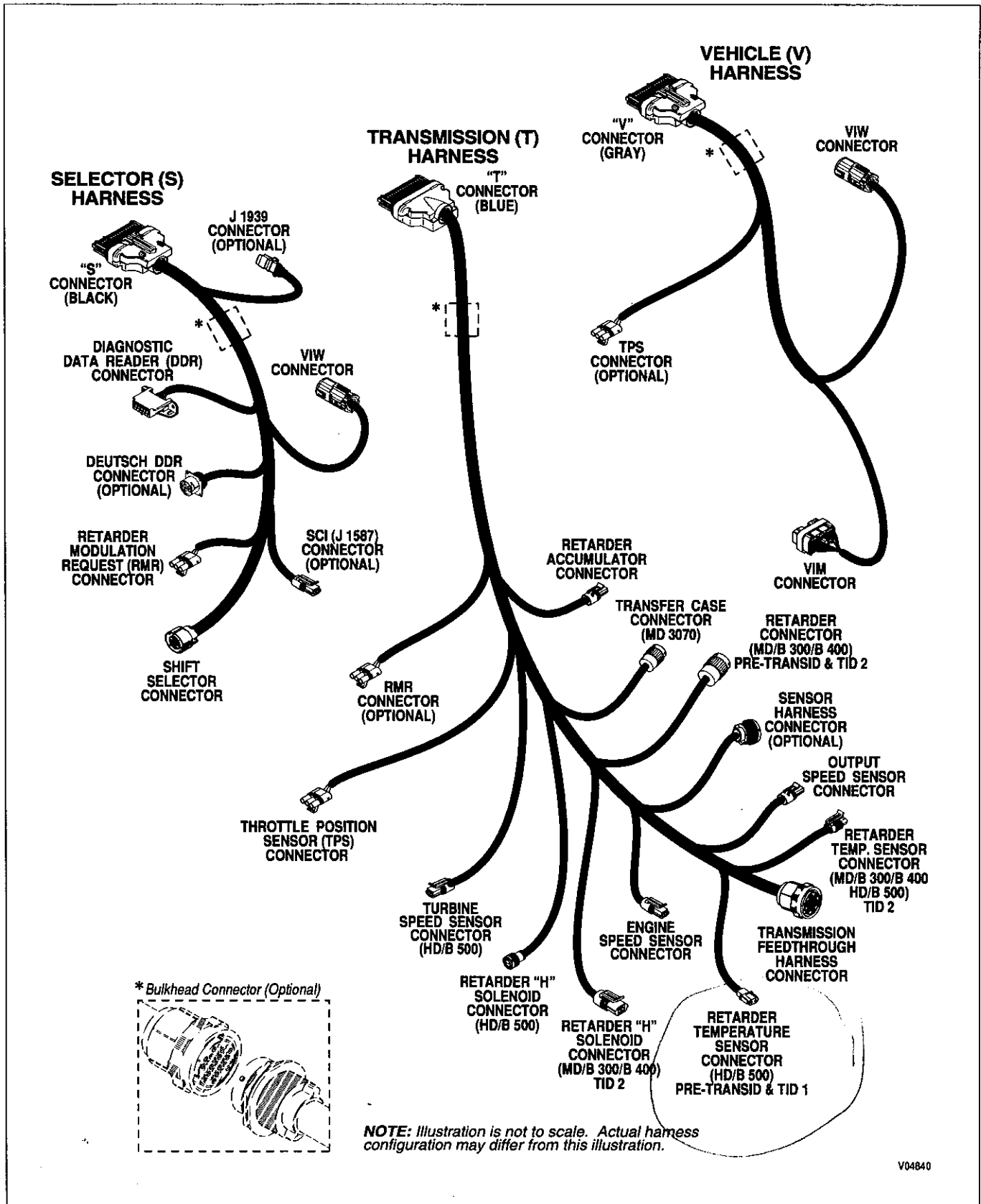

Figure 1-9. WTEC III External Wiring Harnesses

GENERAL DESCRIPTION

B. Internal Wiring Harness (Figure 1-10)

The internal wiring harness provides connection between the external harness, the pulse width modulated solenoids, oil level sensor, C3 pressure switch, and the temperature sensor.

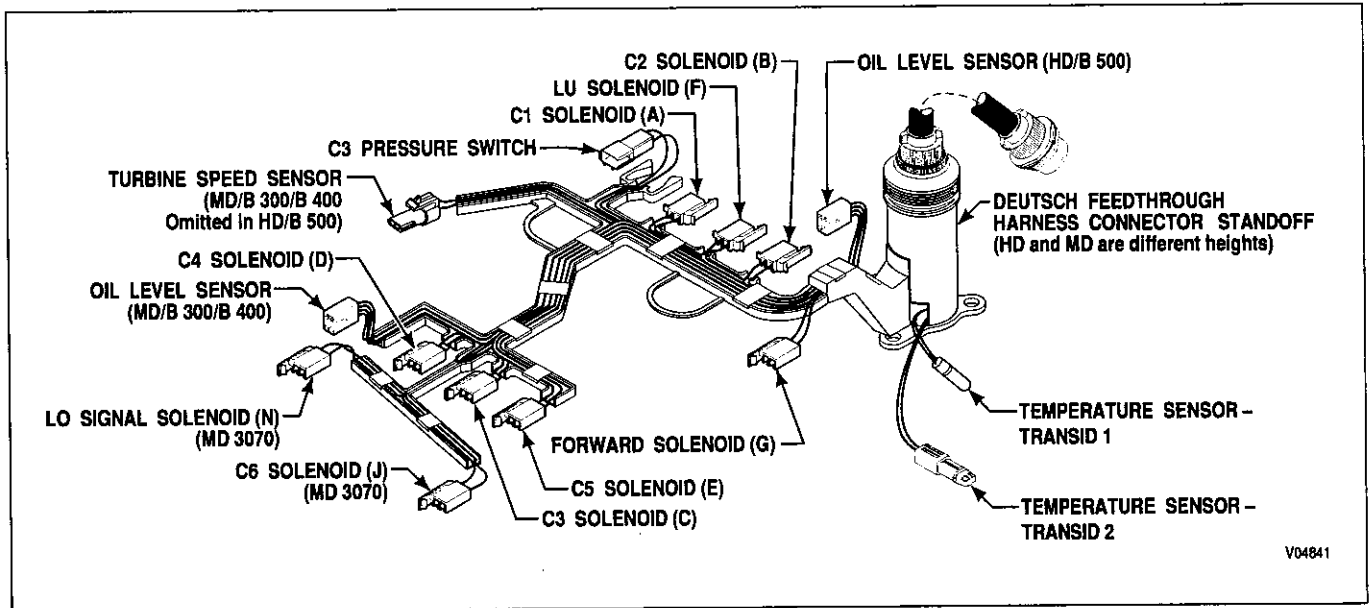

Figure 1-10. WTEC III Internal Wiring Harness

1-8. VEHICLE INTERFACE MODULE (Figure 1-11)

The vehicle interface module (VIM) provides relays, fuses, and connection points for interface with the output side of the vehicle electrical system. VIMs are available for both 12V and 24V electrical systems. The VIM for 12V systems uses all 12V relays. The VIM for 24V systems has all 24V relays. Refer to the Parts Catalog for the transmission assembly number that you are servicing for detailed parts information. Refer to pages D-23 and D-24 for VIM wire number and terminal information.

Some OEMs may provide their own equivalent for the VIM which performs the same functions as the VIM shown in Figure 1-11.

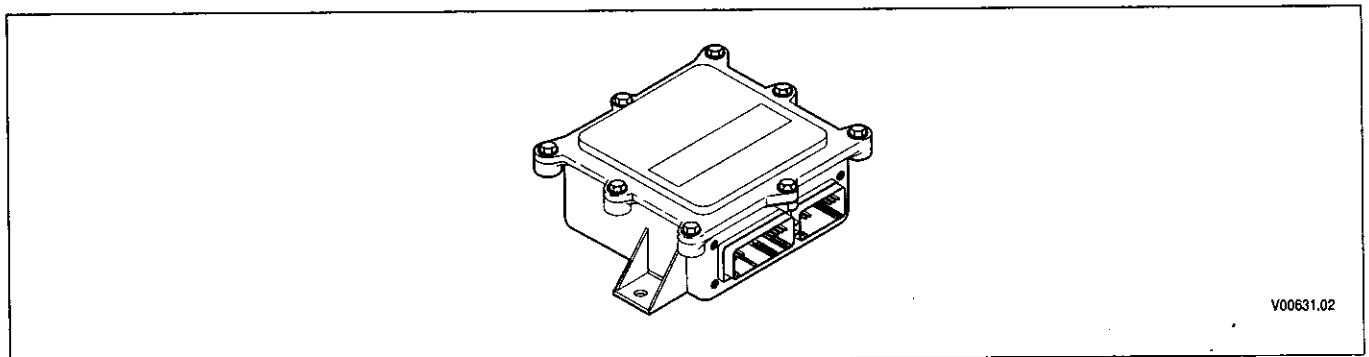

Figure 1-11. Vehicle Interface Module (VIM)

GENERAL DESCRIPTION

1-9. AUTODETECT FEATURE

Autodetect is active on the first 24 engine starts or 49 engine starts, depending upon the component or sensor being detected (details follow in A through D below). Autodetect takes place within the first 30 seconds of each engine start monitored. Autodetect searches for the presence of the following transmission components or data inputs:

Retarder	Present, Not Present
Oil Level Sensor (OLS)	Present, Not Present
Throttle	Analog, J1939, J1587
Engine Coolant Temperature	Analog, J1939, J1587

Even after autodetect has been completed, it can be reset to monitor an additional group of engine starts. Reset may be necessary if a device known to be present is not detected or if an autodetectable component or sensor was added after the initial vehicle build. Reset is accomplished by using the Pro-Link®. Using a WTEC II Pro-Link®, select "RESET TO UNADAPTED SHIFTS". Using a WTEC III Pro-Link®, select "RESET AUTODETECT PARAMETERS". The WTEC III Pro-Link® can also be used to override autodetect and manually enter the component or sensor to be recognized by the ECU by changing appropriate "customer modifiable parameters". Consult the WTEC III Pro-Link® manual for detailed instructions related to WTEC III "customer modifiable parameters". These parameters must be modified during the first 24 engine starts. Changes to "customer modifiable parameters" made after the first 24 engine starts are ignored by the ECU. During the first 24 engine starts, autodetect does not remember what was detected on the previous engine start. For example, if a retarder was detected on engine start 23, H solenoid diagnostics would be performed until the ECU is turned off. If the H solenoid then failed prior to engine start 24, autodetect would not know that a retarder was present on engine start 24 and no diagnostics would be conducted for solenoid H. Additional details for each of the four detectable features are given below.

A. Retarder

Autodetect searches for the presence of the H (retarder) solenoid during the first 24 engine ignition cycles. The H solenoid must be present on the 24th engine start or the retarder is not detected and will not function on subsequent engine starts.

WARNING!

If a retarder is present but is not detected by autodetect, the retarder will not function. Be sure to check for proper retarder function immediately after the 24th engine start. If the retarder is not functioning, check H solenoid for open, short-to-ground or short-to-battery condition. Use Pro-Link® to reset autodetect or to manually select the presence of the retarder after the H solenoid circuit is repaired.

B. Oil Level Sensor (OLS)

NOTE: *If an OLS is known to be present, but has not been detected, a possible cause is that the transmission fluid level is too low. Check the fluid level before beginning OLS troubleshooting.*

No oil level sensor diagnostics take place until the OLS is detected. Frequently check for the presence of oil level diagnostics if the transmission is known to contain an OLS. If an OLS is not detected during the first 24 engine starts, autodetect continues through engine start number 49. Autodetect stops between engine start 24 and 49 when an OLS is detected or concludes that no OLS is present if the OLS is not detected on engine start number 49. If an OLS is known to be present, but has not been detected, then troubleshooting of the OLS circuit is required. After the OLS circuit is repaired, reset autodetect or manually select the OLS function using the Pro-Link®.

GENERAL DESCRIPTION

C. Throttle Source

Whenever autodetect is functioning and no throttle source is found, a code 26 00 is logged. If a datalink throttle source (J1939 or J1587) is detected, autodetect stops looking for that function. However, if no analog throttle source was detected prior to engine start 25, autodetect continues for engine starts 25 through 49. Autodetect for analog throttle stops as soon as a device is detected or at engine start 49. If an analog throttle source is known to be present at engine start 49, but is not detected, troubleshooting of the analog throttle circuit is required. After the analog throttle circuit is repaired, reset autodetect or manually select the analog throttle function using the Pro-Link®. An engine throttle source must be present. A PWM throttle source requires a unique calibration or must be manually selected using the Pro-Link®.

D. Engine Coolant Temperature

Autodetect looks for an engine coolant temperature source during the first 24 engine starts. However, code 26 11 is not logged unless the calibration calls for engine coolant temperature data to be used for retarder capacity reduction or preselect downshifts due to retarder overheating. Autodetect remembers whatever engine coolant temperature source was present on engine start 24. If no analog engine coolant temperature source is found on engine start 24, autodetect concludes that no sensor is present. Therefore, if an engine coolant temperature is known to be present at engine start 24, but is not detected, troubleshooting of the engine coolant temperature circuit is required. After the engine coolant temperature circuit is repaired, reset autodetect or manually select the engine coolant temperature function using the Pro-Link®.

1-10. TRANSID FEATURE

A. General Description

The TransID feature has been provided so that Allison Transmission can make component changes which require calibration changes but still retain both the original transmission A/N and the original calibrated ECU A/N. The purpose of TransID is to reduce the need for OEMs to use cross-reference lists of transmission and calibrated ECU A/Ns when such changes to the transmission are made. TransID allows OEMs to order specific transmission A/Ns and calibrated ECU A/Ns and receive all changes made to the transmission and all of the corresponding calibrations. This will reduce the number of A/N changeovers with which an OEM must contend.

The basis for the TransID system is the creation of a TransID wire in the WTEC III system to provide the signal to the ECU of the TransID level of the transmission. This wire will at first be connected directly to the Analog Ground (wire 135) to signal TransID level 1 (TID 1). TransID levels 2 through 8 will then be indicated by connecting the TransID wire in sequence to the ground of solenoids A, B, C, D, E, G, and F. Corresponding to the hardware changes is the ability in the V8A WTEC III ECU to contain up to eight calibrations. The connection point of the TransID wire will provide the signal to tell the ECU which calibration is required by the transmission.

Whenever a TransID level change is to be made, the new TransID level calibrations will be placed in the PROM Calibration Configurator System (PCCS) ninety days before the change(s) is(are) made in production to the transmissions. All ECUs programmed and sold after that date will then be loaded with the new TransID level calibration. These ECUs will contain calibrations for the new level transmission and all previous TransID levels and will automatically load the correct calibration for the transmission based on the TransID signal sensed by AutoDetect during the first twenty-five engine starts. This eliminates worry on the part of the OEM of coordinating the implementation of the new ECU and the new transmission and allows their focus to be on using the stock of the earlier level ECU.

GENERAL DESCRIPTION

B. Transmission Changes Versus TransID Number

1. TransID 1

The internal wiring harness wiring change to make a TID 1 transmission was put into production before the introduction of the WTEC III system. The TID 1 internal harness was made by connecting the C3 Pressure Switch ground (digital/signal ground; WTEC II wire 161) to the Sump Temperature Sensor and Oil Level Sensor ground (analog ground; wire 135) in the internal harness. In WTEC II, the signal ground wire (wire 161) is routed through the transmission connector, terminal W, and then to the ECU, terminal B27. In WTEC III, this same wire in the internal harness becomes the TransID wire (wire 195), and it goes to the ECU, terminal T13 (blue connector). The purpose of TransID 1 was to provide a common transmission for use with both WTEC II and WTEC III systems (V7A and V8).

The only difference between a pre-TransID transmission and a TransID 1 transmission is the internal wiring harness which connects the digital and analog grounds on the TID 1 harness. Adapter harness P/N 200100 can be ordered from St. Clair Technologies to provide the same connection outside the transmission and allow a pre-TransID transmission to be “converted” to a TransID 1 transmission.

All models of the World Transmission were built with the TransID 1 internal (feedthrough) harness beginning in September, 1996. Two changes were rolled into this update: the wiring change for TID 1 and a change to use a molded channel rather than the braided covering which was previously used. Both changes were rolled into the same internal harness P/N even though there was a delay in implementing the channel which resulted in the two S/N breaks. Table 1–1 lists the harness P/Ns for the different transmission models along with the S/Ns for both changes for each harness.

Table 1–1. TransID 1 S/N Breakpoint

Transmission Model	Pre-TransID Harness P/N	TransID 1 Harness P/N	S/N at Wiring Change	S/N at U-Channel
MD 3000/B 300/B 400 w/OLS	29516322	29529472	6510088864	6510096671
MD 3000/B 300/B 400 w/o OLS	29516323	29529473	6510089316	6510096683
MD 3070 PT	29516324	29529474	6510090786	6510096675
HD 4000/B 500 w/OLS	29516325	29529475	6610014067	6610015591
HD 4000/B 500 w/o OLS	29516326	29529476	6610014084	6610015700

2. TransID 2

The purpose of the TransID 2 change is to indicate the use of new sump and retarder temperature sensors (thermistors) and a new retarder design. The new retarder requires a different calibration than the old retarder. Retarder performance complaints will occur if the new retarder is controlled by the old retarder calibration or the old retarder is controlled by the new retarder calibration. TransID 2 internal harnesses contain both the new sump temperature sensor and a new connection point for the TransID wire. The TransID wire (195) is connected to Solenoid A ground (wire 120) to signal TID 2 to the ECU. The new temperature sensors are discussed below. A TransID 2 transmission will only work with a V8A ECU (WTEC III) and V8A ECUs are calibrated to accommodate both TransID 1 and TransID 2 transmissions.

GENERAL DESCRIPTION

The internal harness change to all models for TID 2 began in late December, 1997 production. The S/N breakpoints are shown in Table 1-2.

Table 1-2. TransID 2 S/N Breakpoint

Transmission Model	TransID 1 Harness P/N	TransID 2 Harness P/N	S/N at Thermistor and Wiring Change
MD 3000/B 300/B 400 w/OLS	29529472	29533652	6510141464
MD 3000/B 300/B 400 w/o OLS	29529473	29533653	6510141470
MD 3070 PT	29529474	29533654	6510142172
HD 4000/B 500 w/OLS	29529475	29533655	6610026328
HD 4000/B 500 w/o OLS	29529476	29533656	6610026319

The new retarder thermistor used on TransID 2 retarder model transmissions has a molded connector and is the same on all TransID 2 retarders. The TransID 1 and pre-TransID retarder thermistor had a two terminal connector attached to it when it was used on B 500R/HD 4000R transmissions. It was part of a retarder harness assembly when used on B300R/B 400R/MD 3000R transmissions. See Appendix Q which describes the new and old temperature sensors. A graph and a table of resistance values for different temperatures are also included in Appendix Q.

Table 1-3 shows the old (pre-TransID and TransID 1) and the new (TransID 2) part numbers of the retarder temperature sensors and the serial number when the change was made.

Table 1-3. New Retarder Temperature Sensor S/N Breakpoint

Transmission Model	Former Thermistor Used	P/N Where Former Thermistor Used	New Thermistor P/N (TID 2)	First S/N For New Thermistor
B 300R/B 400R/MD 3000R	built into retarder harness	29510662	15326309	6510142059
B 500R/HD 4000R	built with connector attached	29511861	15326309	6610026472

C. Compatibility Between TransID Level And ECU Calibration Level

Table 1-4 shows the compatibility of the different ECU software levels with the different TransID level transmissions.

Table 1-4.

	CIN Compatibility Number	Software Level	Compatible with TransID level	ECU Production Dates
WTEC II	07	V6E	pre-TransID and TID 1	until 9/94
	08	V7 and V7A	pre-TransID and TID 1	9/94 until 12/97
WTEC III	0A	V8	TID 1	2/97 until 9/97
	0B	V8A	TID 1 and TID 2	beginning 10/97

GENERAL DESCRIPTION

The manufacture and sale of both WTEC II and WTEC III ECUs during most of 1997 required a means of using a common transmission with either a WTEC II or a WTEC III ECU. A TID 1 transmission is the common transmission configuration for both control systems and production began in September, 1996 (see Table 1-3). A TransID level 1 transmission is compatible with V6E, V7, V7A, V8, and V8A ECUs.

TransID level 2 transmissions were produced beginning in late December, 1997 (see Table 1-4). A TransID 2 transmission is compatible with only V8A ECUs.

Pre-TransID transmissions are only compatible with V6E, V7, and V7A ECUs. Pre-TransID transmissions were produced before the first S/N break in Table 1-3.

SECTION 2 — DEFINITIONS AND ABBREVIATIONS

2-1. CHECK TRANS LIGHT

When the ECU detects a serious fault, the **CHECK TRANS** light (usually located on the vehicle instrument panel) illuminates and action is automatically taken to protect operator, vehicle, and the transmission. A diagnostic code will nearly always be registered when the **CHECK TRANS** light is on; however, not all diagnostic codes will turn on the **CHECK TRANS** light. Codes related to the **CHECK TRANS** light are detailed in the code chart (refer to Section 6).

Illumination of the **CHECK TRANS** light indicates that a condition was detected that requires service attention. Operation may or may not be restricted but even when restricted will allow the vehicle to reach a service assistance location. Depending upon the cause for the **CHECK TRANS** light illumination, the ECU may or may not respond to shift selector requests. The transmission may be locked in a range. That range will be shown on the shift selector display. Both upshifts and downshifts may be restricted when the **CHECK TRANS** light is illuminated. Seek service assistance as soon as possible.

Each time the engine is started, the **CHECK TRANS** light illuminates briefly and then goes off. This momentary lighting shows the light circuit is working properly. If the light does not come on during engine start, request service immediately.

2-2. DIAGNOSTIC DATA READER (Figure 2-1)

The current Diagnostic Data Reader (DDR) is the Pro-Link® 9000 diagnostic tool which is available through Kent-Moore Heavy-Duty Division. A portable microcomputer-based receiver/transmitter/display unit, the Pro-Link® transmits and receives data to and from the ECU, processes the data, and displays appropriate information. Use the Pro-Link® during installation checkout and troubleshooting. There is a new Pro-Link® cartridge needed for use with WTEC III controls. The new Multi-Protocol Cartridge (MPC) contains a programmed PCMCIA card which allows for reprogramming of GPI/GPO packages. Reprogramming includes selection of a GPI/GPO package, enabling/disabling of wires and modification of certain data parameters. Operating instructions are supplied with each Pro-Link® and further information is also included in Appendix N of this manual. Connect the Pro-Link® 9000 to the diagnostic connector provided in the selector wiring harness.

Tool part numbers for the Pro-Link® are as follows:

- Diagnostic Kit J 38538D + J 38500-313 (PROM Update) = J 38538E
- Diagnostic Cartridge J 38500-302 + J 38500-313 = J 38500-303
- MPC J 38500-1500C
- PCMCIA (Diagnostic And Reprogramming) J 38500-1700B
- PCMCIA (Diagnostic Only) J 38500-1800A

NOTE: *The new MPC is usable with WTEC II controls but the old WTEC II reprogramming cartridge will not display the WTEC III new information. The new MPC must be used to reprogram WTEC III systems.*

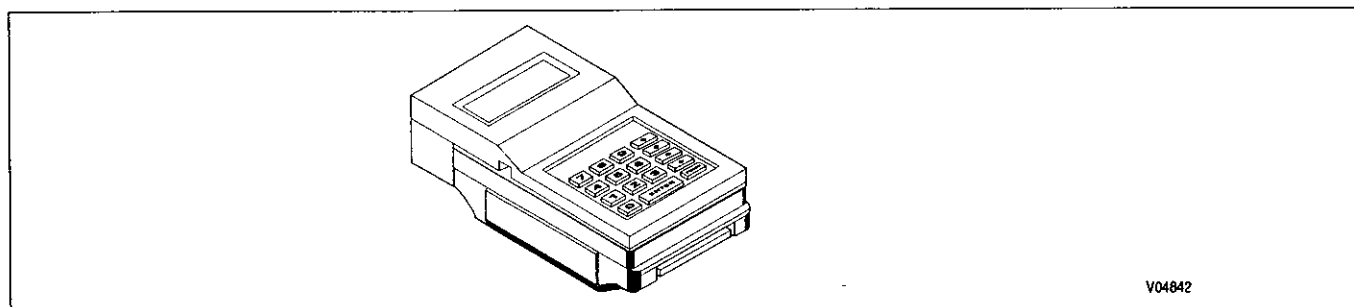

V04842

Figure 2-1. Pro-Link® 9000 Diagnostic Tool

DEFINITIONS AND ABBREVIATIONS

2-3. ABBREVIATIONS

A/N	Assembly Number
ABS	Anti-lock Brake System — OEM-provided means to detect and prevent wheel stoppage to enhance vehicle handling. Retarder and engine brakes will not apply when ABS is active.
Amp	Unit of electrical current.
C3PS	C3 Pressure Switch — Pressure switch to signal the presence or absence of pressure in the C3 clutch-apply circuit.
CAN	Controller Area Network — A network for all SAE J1939 communications in a vehicle (engine, transmission, ABS, etc.)
COP	Computer Operating Properly — Hardware protection which causes the ECU to reset if software gets lost.
CT	Closed Throttle
DDR	Diagnostic Data Reader — Diagnostic tool; most current version is the Pro-Link® 9000 made by MicroProcessor Systems, Inc. Used to interrogate the ECU for diagnostic information and for reprogramming I/O packages in a calibration.
DNA	Does Not Adapt — Adaptive shift control is disabled.
DNS	DO NOT SHIFT — Refers to the DO NOT SHIFT diagnostic response during which the CHECK TRANS light is illuminated and the transmission will not shift and will not respond to the Shift Selector.
DVOM	Digital volt/ohmmeter
ECU	Electronic Control Unit (also commonly referred to as the “computer”)
GPI	General Purpose Input — Input signal to the ECU to request a special operating mode or condition.
GPO	General Purpose Output — Output signal from the ECU to control vehicle components (such as PTOs, backup lights, etc.) or allow a special operating mode or condition.
J1587	Engine/transmission serial data communications link.
J1939	High-speed vehicle serial data communications link.
LED	Light-Emitting Diode — Electronic device used for illumination.
NNC	Neutral No Clutches — Neutral commanded with no clutches applied.
NVL	Neutral Very Low — The ECU has sensed turbine speed below 150 rpm. This is usually caused by a dragging C1 or C3 clutch or a failed turbine speed sensor. When attained, the C4 and C5 clutches are applied to lock the transmission output.
OEM	Original Equipment Manufacturer — Maker of vehicle or equipment.
Ohm	Unit of electrical resistance.
OL	Over Limit or Oil Level — For Over Limit see “∞”. Indicates Oil Level is being displayed on a shift selector.
OLS	Oil Level Sensor — Electronic device (optional) on control module for indicating transmission fluid level.

DEFINITIONS AND ABBREVIATIONS

2-3. ABBREVIATIONS (*cont'd*)

PCCS	PROM Calibration Configurator System
PCMCIA	Personal Computer Memory Card International Association — Memory device for use with Pro-Link® containing Allison Transmission programming and diagnostics.
PROM	Programmable Read Only Memory
PSS	Primary Shift Selector — Main shift selector in a two-selector control system.
PTO	Power Takeoff
PWM Solenoid	Pulse Width Modulated Solenoid — Solenoids are controlled by pulse width modulation. Solenoid control of clutch pressures is based on the solenoid's duty cycle. Duty cycle is determined by the ratio of solenoid's on-time to off-time.
RMR	Retarder Modulation Request — Signal from a retarder control device.
RPR	Return to Previous Range — Diagnostic response in which the transmission is commanded to return to previously commanded range.
SCI	Serial Communication Interface — Used to transmit data and messages between the diagnostic tool and the ECU and other systems such as electronically-controlled engines.
SOL OFF	All SOLenoids OFF
SPI	Serial Peripheral Interface — The means of communication between the microprocessor and the interface circuits.
SSS	Secondary Shift Selector — Alternate shift selector in a two-selector control system.
TID	TransID — A feature which allows the ECU to know the transmission configuration and provide the corresponding calibration required.
TPS	Throttle Position Sensor — Potentiometer for signaling the position of the engine fuel control lever.
V	Version — Abbreviation used in describing ECU software levels.
VDC	Volts Direct Current (DC)
VIM	Vehicle Interface Module — A watertight box containing relays and fuses — interfaces the transmission electronic control system with components on the vehicle.
VIW	Vehicle Interface Wiring — Interfaces ECU programmed input and output functions with the vehicle wiring.
Volt	Unit of electrical force.
VOM	Volt/ohmmeter
WOT	Wide Open Throttle
WT	World Transmission
∞	Infinity — Condition of a circuit with higher resistance than can be measured, effectively an open circuit.

DEFINITIONS AND ABBREVIATIONS

NOTES

SECTION 3 — BASIC KNOWLEDGE

3-1. BASIC KNOWLEDGE REQUIRED

To service WTEC III Electronic Controls, the technician must understand basic electrical concepts. Technicians need to know how to use a volt/ohmmeter (VOM) to make resistance and continuity checks. Most troubleshooting checks consist of checking resistance, continuity, and checking for shorts between wires and to ground. The technician should be able to use jumper wires and breakout harnesses and connectors. Technicians unsure of making the required checks should ask questions of experienced personnel or find instruction.

The technician should also have the mechanical aptitude required to connect pressure gauges or transducers to identified pressure ports used in the troubleshooting process. Pressure tap locations and pressure values are shown in Appendix B — Checking Clutch Pressures.

Input power, ground, neutral start circuitry, etc., can cause problems with electronic controls or vehicle functioning and may not generate a diagnostic code. A working knowledge of WT Series Electronic Controls vehicle installation is necessary in troubleshooting installation-related problems.

Refer to Section 8 for information concerning performance complaints (non-code) troubleshooting. A complete wiring schematic is shown in Appendix J. Refer to the WTEC III Controls and General Information Sales Tech Data Book for information concerning electronic controls installation and the Installation Checklist. Reliable transmission operation and performance depend upon a correctly installed transmission. Review the Installation Checklist in the MD, HD, B 300/B 400, and B 500 Sales Tech Data Books to ensure proper installation.

NOTE: *Allison Transmission is providing for service of wiring harnesses and wiring harness components as follows:*

- Repair parts for the internal wiring harness and for wiring harness components attached to the shift selector will be available through the Allison Transmission Parts Distribution Center (PDC). Use the P/N from your appropriate parts catalog or from Appendix E in this manual. Allison Transmission is responsible for warranty on these parts.
- Repair parts for the external harnesses and external harness components must be obtained from St. Clair Technologies Inc. (SCTI). SCTI provides parts to any Allison customer or OEM and is responsible for warranty on these parts. SCTI recognizes ATD, manufacturers, and SCTI part numbers. SCTI provides a technical HELPLINE at 519-627-1673 (Wallaceburg). SCTI will have parts catalogs available. The SCTI addresses and phone numbers for parts outlets are:

St. Clair Technologies, Inc.
1050 Old Glass Road
Wallaceburg, Ontario, Canada, N8A 3T2
Phone: (519) 627-1673
Fax: (519) 627-4227

St. Clair Technologies, Inc.
1111 Mikesell Street
Charlotte, Michigan 48813
Phone: (517) 541-8166
Fax: (517) 541-8167

St. Clair Technologies, Inc.
c/o Mequilas Tetakawi
Carr. Internationale KM 1969
Guadalajara – Nogales, KM2
Empalme, Sonora, Mexico
Phone: 011-52-622-34661
Fax: 011-52-622-34662

- The Allison Transmission PDC will stock a WTEC III external harness repair kit, P/N 29532362, as an interim parts source for some external harness repair parts. SCTI will have a more complete stock and should be considered the prime source for external harness repair parts.

BASIC KNOWLEDGE

3-2. USING THE TROUBLESHOOTING MANUAL

Use this manual as an aid to troubleshooting the WTEC III Electronic Controls. Every possible problem and its solution cannot be encompassed by any manual. However, this manual does provide a starting point from which most problems can be resolved.

Once a problem solution is discovered in the manual do not look further for other solutions. It is necessary to determine *why* a problem occurred. For example, taping a wire that has been rubbing on a frame rail will not correct the problem unless the rubbing contact is eliminated.

3-3. SYSTEM OVERVIEW

WTEC III Electronic Control functions are controlled by the ECU. The ECU reads shift selector range selection, output speed, and throttle position to determine when to command a shift. When a shift occurs, the ECU monitors turbine speed, output speed, and throttle position to control the oncoming and off-going clutches during the shift.

When the ECU detects an electrical fault, it logs a diagnostic code indicating the faulty circuit and may alter the transmission operation to prevent or reduce damage.

When the ECU detects a non-electrical problem while trying to make a shift, the ECU may try that shift a second or third time before setting a diagnostic code. Once that shift has been retried, and a fault is still detected, the ECU sets a diagnostic code and holds the transmission in a fail-to-range mode of operation.

3-4. IMPORTANT INFORMATION IN THE TROUBLESHOOTING PROCESS

Before beginning the troubleshooting process, read and understand the following:

- WTEC III wire identification presents the wire number followed by the ECU terminal source (i.e., 157-S30). If there is a letter suffix following the wire number, there is a splice between the ECU source and wire destination (i.e., 136A-S16).
- Shut off the engine and ignition before any harness connectors are disconnected or connected.
- Remember to do the following when checking for shorts and opens:
 - Minimize movement of wiring harnesses when looking for shorts. Shorts involve wire-to-wire or wire-to-ground contacts and moving the harnesses may eliminate the problem.
 - Wiggle connectors, harnesses, and splices when looking for opens. This simulates vehicle movements which occur during actual operation.
- When disconnecting a harness connector, be sure that pulling force is applied to the connector itself and **not the wires** extending from the connector.
- Resistance checks involving the wiring between the ECU connectors and other components adds about one ohm of resistance to the component resistance shown.

BASIC KNOWLEDGE

- Inspect all connector terminals for damage. Terminals may have bent or lost the necessary tension to maintain firm contact.
- Clean dirty terminals or connectors with isopropyl alcohol and a cotton swab, or a good quality, non-residue, non-lubricating, cleaning solvent such as LPS Electro Contact Cleaner® or LPS NoFlash Electro Contact Cleaner®.

CAUTION:

The cleaning solvent must not be chlorine based, contain petroleum distillates, or conduct electricity. The cleaning solvent should evaporate quickly to prevent the possibility of condensation within the connectors. Always blow or shake any excess cleaner from the connector before assembling it to its mating connector or hardware. Cleaner trapped in the connector can affect the connector seal. (Refer to SIL 17-TR-94 for detailed information on the recommended cleaners.)

CAUTION:

Care should be taken when welding on a vehicle equipped with electronic controls. Refer to Appendix G, Paragraph 1-1.

- Diagnostic codes displayed after system power is turned on with a harness connector disconnected, can be ignored and cleared from memory. Refer to Section 6, Diagnostic Codes, for the code clearing procedure.

3-5. BEGINNING THE TROUBLESHOOTING PROCESS

NOTE: *Whenever a transmission is overhauled, exchanged, or has undergone internal repairs, the Electronic Control Unit (ECU) must be "RESET TO UNADAPTED SHIFTS". See Service Information Letter 16-WT-96, Revision A for further details.*

1. Begin troubleshooting by checking the transmission fluid level and ECU input voltage. Remember that some problems may be temperature related. Do troubleshooting at the temperature level where the problem occurs. Check diagnostic codes by:
 - Using the shift selector display. (See Paragraph 6-2 for code reading.)
 - Using the Pro-Link® 9000 diagnostic tool.
2. When a problem exists but a diagnostic code is not indicated, refer to the Performance Complaint Section (Section 8) for a listing of various electrical and hydraulic problems, their causes, and remedies.
3. If a diagnostic code is found in the ECU memory, record all available code information and clear the active indicator (refer to Section 6).
4. Test drive the vehicle to confirm a diagnostic code or performance complaint.
 - If the code reappears, refer to the Diagnostic Code section (Section 6) and the appropriate code chart. The Diagnostic Code section lists diagnostic codes and their description. Locate the appropriate troubleshooting chart and follow the instructions.

BASIC KNOWLEDGE

- If the code does not reappear, it may be an intermittent problem. Use the Pro-Link® and the code display procedure described in Section 6. The code display procedure will indicate the number of times the diagnostic code has occurred. Refer to the troubleshooting chart for possible cause(s) of the problem.
- Appendix A deals with the identification of potential circuit problems. Refer to Appendix A if a circuit problem is suspected.

NOTE: *Information concerning specific items is contained in the appendices located in the back of this manual. The appendices are referred to throughout the manual.*

SECTION 4 — WIRE CHECK PROCEDURES

4-1. CHECKING OPENS, SHORTS BETWEEN WIRES, AND SHORTS-TO-GROUND
(Use Digital Volt/Ohmmeter J 34520-A and Jumper Wire Set J 39197)

NOTE: Please refer to Paragraph 3-5 to begin the troubleshooting process.

1. Make sure all connectors are tightly connected and re-check the circuit.
2. Disconnect and inspect all connectors.
3. Thoroughly clean corroded or dirty terminals. If dirty or corroded terminals are the probable cause of the problems, reconnect the clean connectors and operate the vehicle normally. If the problem recurs, proceed with Step (4).

CAUTION:

The cleaning solvent must not be chlorine based, contain petroleum distillates, or conduct electricity. The cleaning solvent should evaporate quickly to prevent the possibility of condensation within the connectors. Always blow or shake any excess cleaner from the connector before assembling it to its mating connector or hardware. Cleaner trapped in the connector can affect the connector seal. (Refer to SIL 17-TR-94 for detailed information on the recommended cleaners.)

4. Review the WTEC III wire numbering system described in Paragraph 3-4.
5. If all connectors are clean and connected correctly, determine which wires in the chassis harness are indicated by the diagnostic code. For example, Code 41 12, indicates an open or short-to-ground in the solenoid A circuit — wires 102-T1 and 120-T4.
 - a. Check continuity of wires 102-T1 and 120-T4 by performing the following (refer to Figure 4-1):
 - (1) Disconnect the blue “T” connector from the ECU and disconnect the harness from the transmission main connector. At one end of the harness, using jumper wire kit J 39197 and connector probes in J-39775-CP, connect wire 102-T1 and 120-T4 to each other, being careful not to distort the terminals. Jumping the wires together creates a circuit between wires 102-T1 and 120-T4.

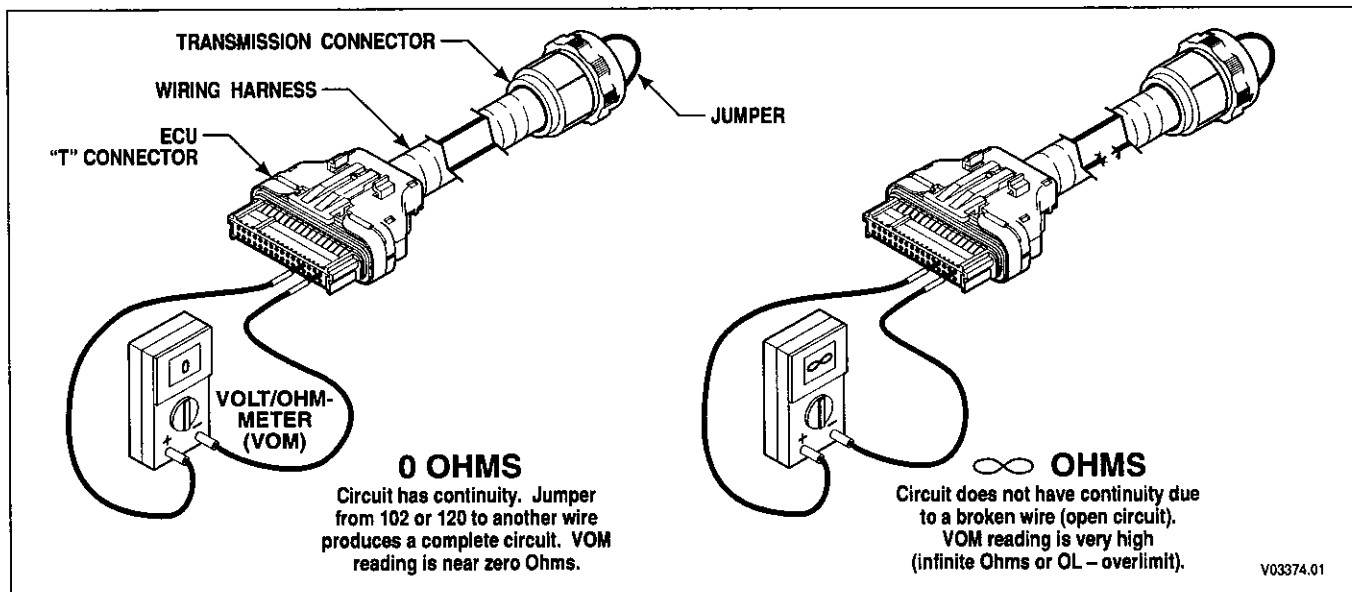

Figure 4-1. Open Circuit

WIRE CHECK PROCEDURES

- (2) On the opposite end of the harness, check the continuity of the jumpered pair. No continuity in a jumpered pair circuit (infinite resistance reading) indicates an open in the wire being tested. Locate and repair the damaged portion of the wire.
- b. If the continuity check is good (0–2 Ohms resistance), remove the jumpers. Check the harness for shorts between wires and shorts-to-ground by performing the following (refer to Figure 4–2):
- (1) At the ECU end of the harness, touch one VOM probe to one wire of the circuit being tested and touch the other probe to each terminal in the same connector, then touch the probe to chassis ground and to the transmission main housing. Do this for both wires in the circuit being tested.
 - (2) If at any time the VOM shows zero to low resistance, or the meter's continuity beeper sounds, there is a short between the two points being probed — wire-to-wire or wire-to-ground. Isolate and repair the short.

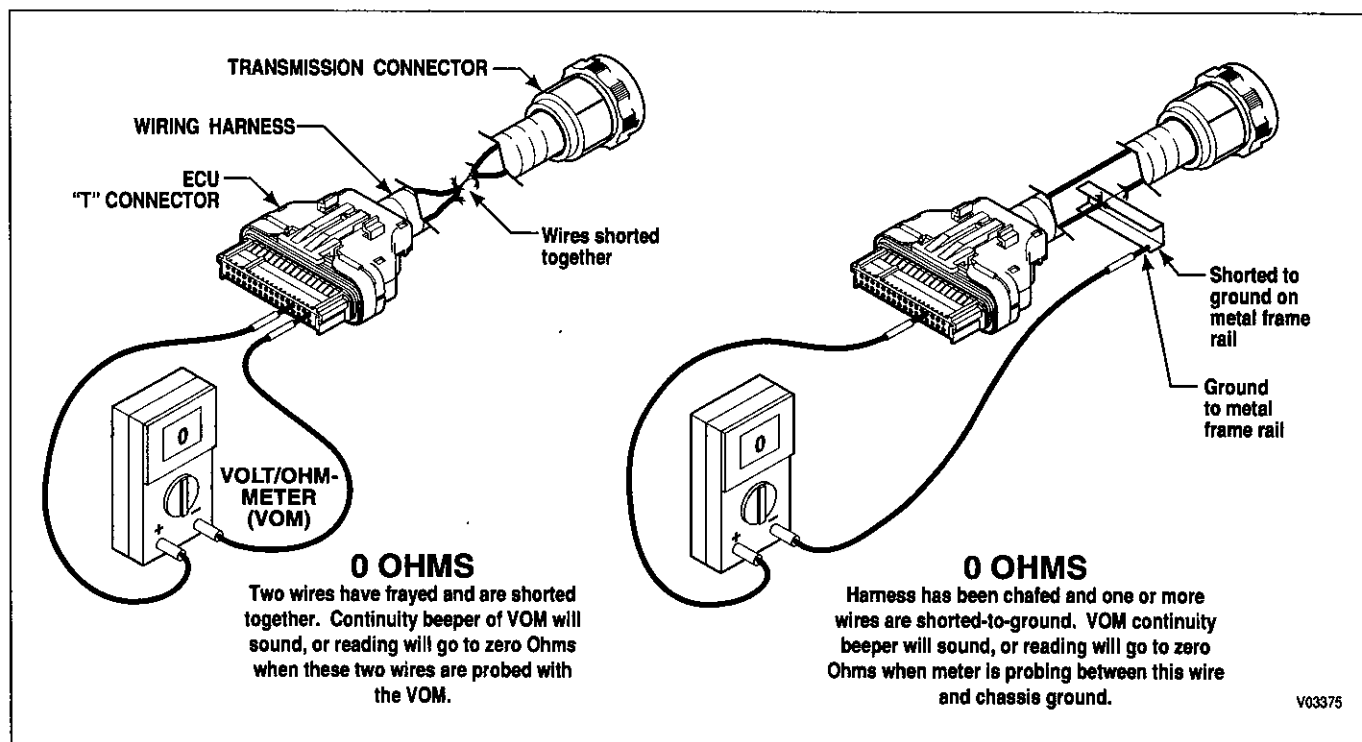

Figure 4–2. Short Between Wires and to Ground

4–2. CHECKING AT TRANSMISSION CONNECTOR AND THE INTERNAL HARNESS FOR OPENS, SHORTS BETWEEN WIRES, AND SHORTS-TO-GROUND

1. Disconnect the external wiring harness from the transmission.
2. Inspect the connectors. Any terminals which are corroded or dirty must be thoroughly cleaned.
3. If the connectors are clean and connected correctly, determine which wires in the harness to test. Use the diagnostic code system schematic to locate the wire terminals. For this example, Code 41 12 indicates an open or short-to-ground in solenoid "A" circuit — wires 102-T1 and 120-T4 (refer to Figure 4–3 and 4–4).

WIRE CHECK PROCEDURES

CAUTION:

The cleaning solvent must not be chlorine based, contain petroleum distillates, or conduct electricity. The cleaning solvent should evaporate quickly to prevent the possibility of condensation within the connectors. Always blow or shake any excess cleaner from the connector before assembling it to its mating connector or hardware. Cleaner trapped in the connector can affect the connector seal. (Refer to SIL 17-TR-94 for detailed information on the recommended cleaners.)

- a. At the transmission connector, check the resistance of the A solenoid circuit. Resistance of a solenoid circuit should be 2.4–5 Ohms — covering a temperature range of -18°C to 149°C (0°F to 300°F). Refer to Solenoid Resistance vs. Temperature chart in Appendix K. No continuity in the circuit (infinite resistance) indicates an open in the internal harness, the feedthrough connector, or the solenoid coil. Locate and repair the open in the internal harness or replace the internal harness, replace the feedthrough connector, or replace the solenoid.

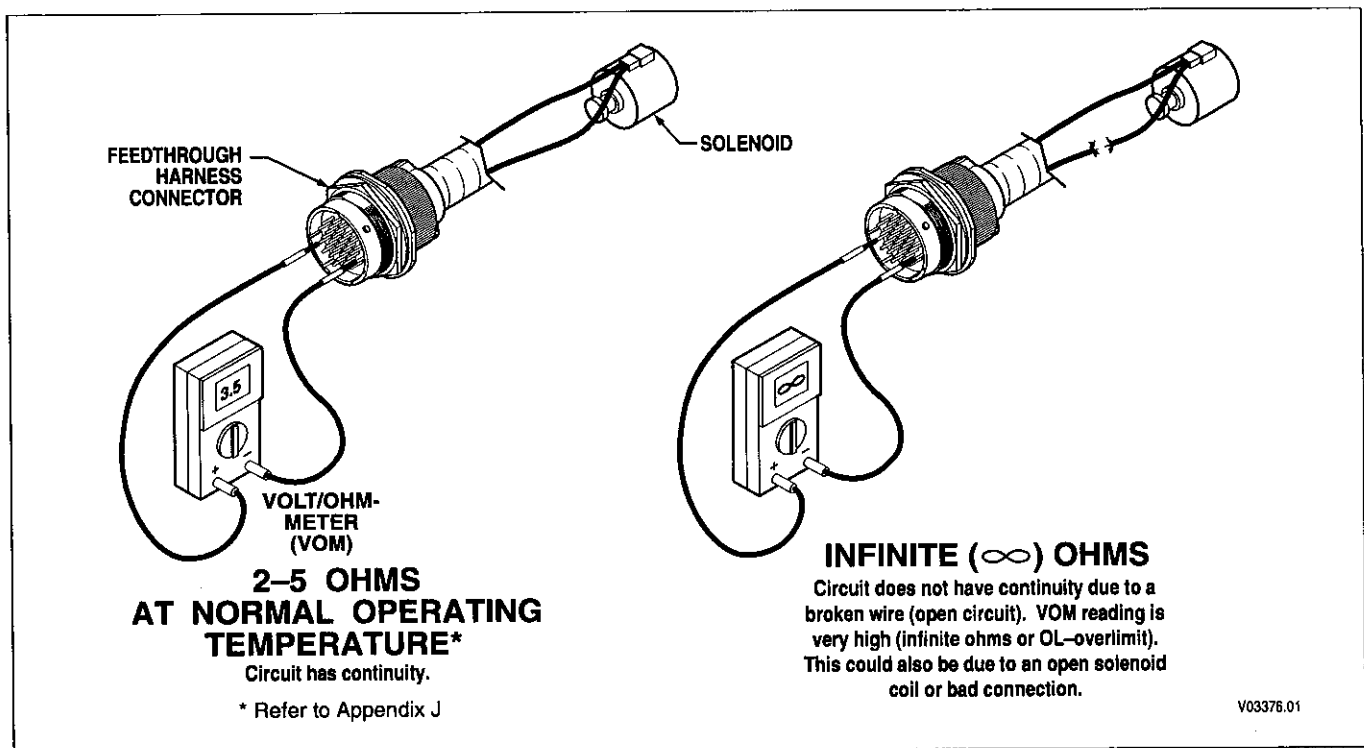

Figure 4-3. Checking Continuity

- b. If the resistance check is good, check the harness for shorts between wires and to ground by performing the following (refer to Figure 4-4):
- (1) At the transmission connector, touch one probe of the VOM to one wire of the circuit being tested and touch the other probe to each terminal in the connector and to chassis ground and the transmission main housing. Do this for both wires in the circuit being tested.
 - (2) If the VOM shows zero to low resistance, or the continuity beeper sounds, there is a short between the two points being probed, wire-to-wire or wire-to-ground. An indication of a short may be caused by a splice to the wire being checked. Check the wiring diagram in Appendix J for splice locations. If the short is not a splice, then isolate and repair the short.

WIRE CHECK PROCEDURES

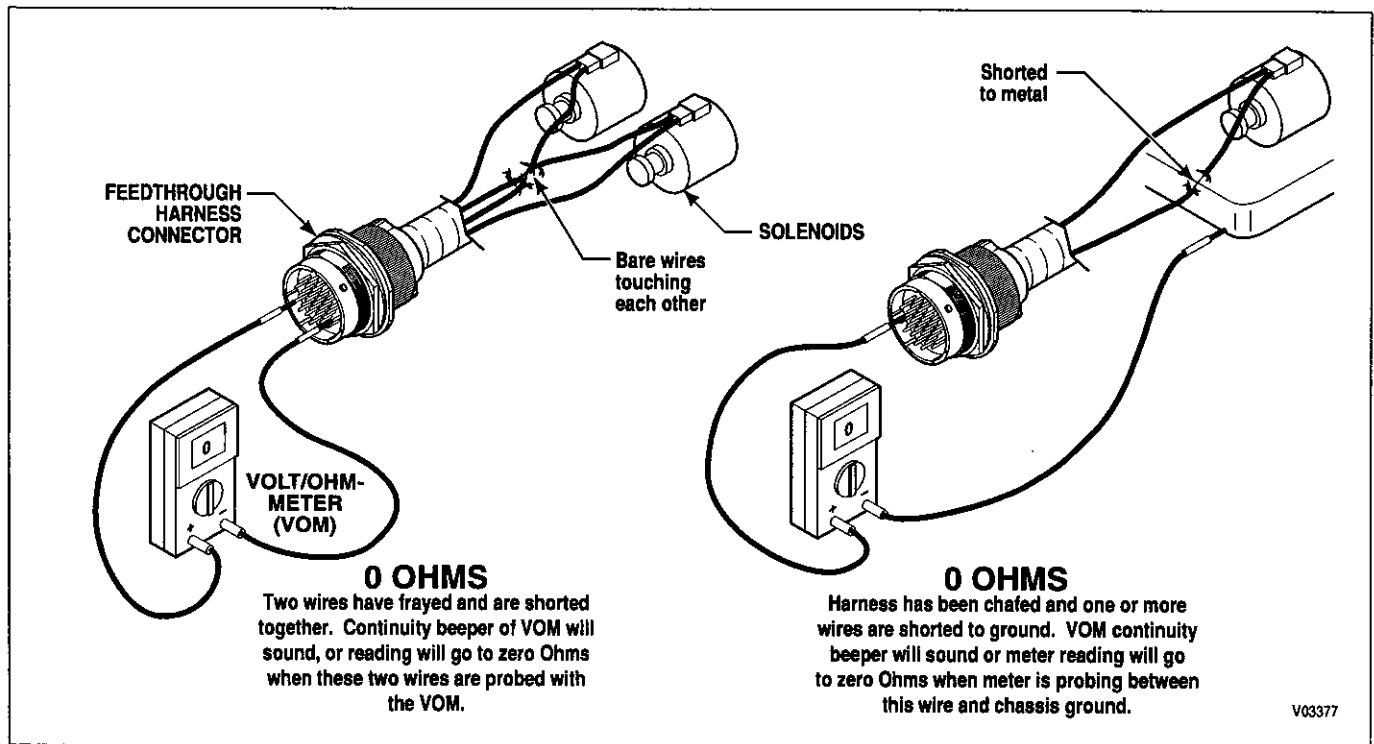

Figure 4-4. Short Between Wires and to Ground

NOTE: *When conducting circuit checks that include the external harness, add one (1) Ohm to the values shown. Speed sensor resistance is 270–330 Ohms. C3 pressure switch resistance is two (2) Ohms maximum when switch is closed and 20,000 Ohms minimum when switch is open.*

SECTION 5 — OIL LEVEL SENSOR

The Oil Level Sensor (Figure 5-1) provides a means of electronically checking the transmission fluid level from the shift selector display, the Pro-Link® 9000 (DDR) diagnostic tool, or a customer-furnished remote display.

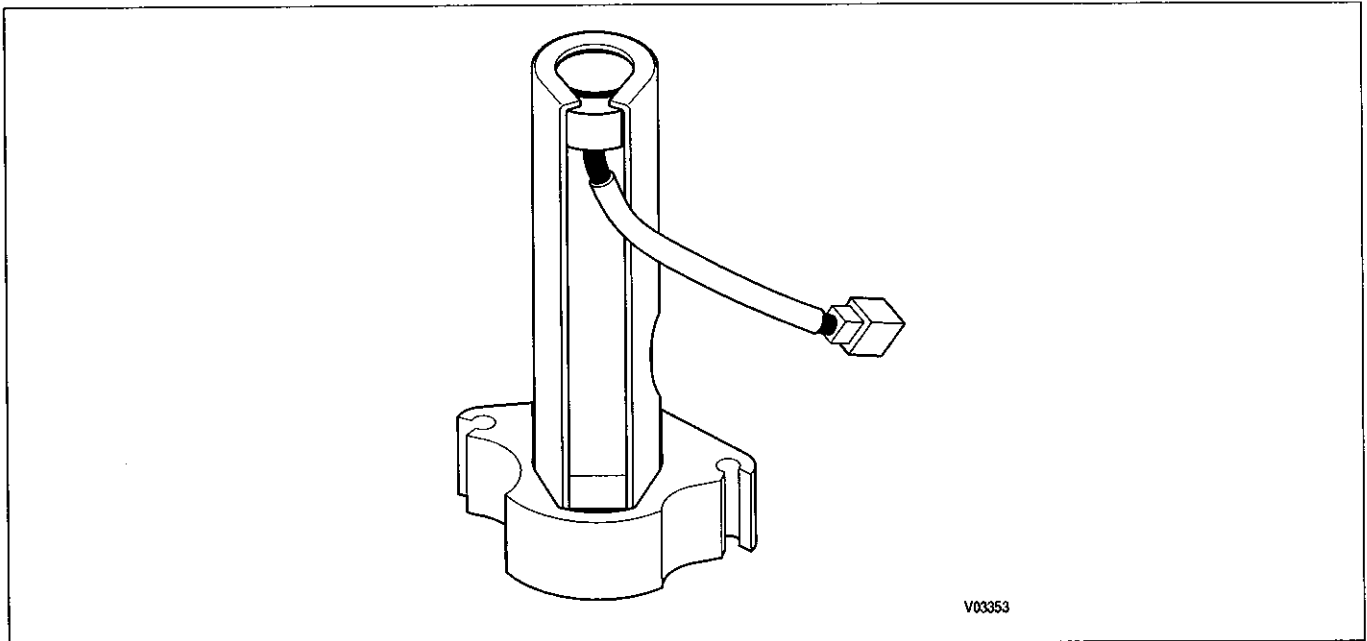

Figure 5-1. Oil Level Sensor

5-1. ELECTRONIC FLUID LEVEL CHECK (SHIFT SELECTOR)

NOTE: *The pushbutton and lever shift selectors can display one character at one time. The strip pushbutton shift selector has no diagnostic or display capability. The Pro-Link® 9000 or a customer-furnished remote display must be used to obtain fluid level information when using the strip pushbutton shift selector.*

A. Fluid Level Check Procedure

1. Park the vehicle on a level surface and shift to N (Neutral). Apply the parking brake.
2. On the Pushbutton shift selector, simultaneously press the ↑ (Up) and ↓ (Down) arrow buttons once.
3. On the Lever shift selector, press the “display mode” button once.
4. For a strip pushbutton shift selector, refer to the Pro-Link® 9000 manual or to Appendix N in this manual.

NOTE: *The ECU may delay the fluid level check until the following conditions are met:*

- *The fluid temperature is between 60°C (140°F) and 104°C (220°F).*
- *The transmission is in N (Neutral).*
- *The vehicle has been stationary for approximately two minutes to allow the fluid to settle.*
- *The engine is at idle (below 1000 rpm — not “fast” idle).*

See “Invalid for Display” information in Steps (8) and (9).

OIL LEVEL SENSOR

5. Correct fluid level is reported when **o, L** is displayed (**o, L** indicates the Oil Level Check Mode), followed by **o, K**. The **o, K** display indicates the fluid level is within the proper fluid level zone. **Remember that the display occurs one character at a time.** The sensor display and the transmission dipstick may not agree exactly because the oil level sensor compensates for fluid temperature.

Example: o, L; o, K — Indicates correct fluid level.

6. Low fluid level is reported when **o, L** is displayed, followed by **L, o** and a number. **L, o** indicates a low fluid level and the number is the number of quarts of fluid the transmission requires.

Example: o, L; L, o; 2 — Indicates 2 additional quarts of fluid will bring the fluid level within the proper fluid level.

7. High fluid level is reported when **o, L** is displayed, followed by **H, I** and a number. **H, I** indicates high fluid level and the number shows how many quarts the transmission is overfilled.

Example: o, L, H, I, 1 — Indicates one quart of fluid above the full level.

CAUTION:

A low or high fluid level causes overheating and irregular shift patterns. An incorrect fluid level can damage the transmission.

8. An Invalid for Display condition is reported when **o, L** is displayed, followed by “-” and a number display. The displayed number is a fault code and indicates improper conditions or a system malfunction.

Example: o, L, -, 7,0 — Indicates an Invalid for Display condition and fault code 70.

9. Invalid for Display is activated when conditions do not allow the fluid level to be checked electronically. Review the following codes and conditions, and correct as necessary.

Table 5-1. Invalid for Display Codes

CODE	CAUSE OF CODE
X* —	Settling time too short
5,0 —	Engine speed (rpm) too low
5,9 —	Engine speed (rpm) too high
6,5 —	N (Neutral) must be selected
7,0 —	Sump fluid temperature too low
7,9 —	Sump fluid temperature too high
8,9 —	Output shaft rotation
9,5 —	Sensor failure**
* A number between 8 and 1 that flashes during the count-down period.	
** Speed sensor, throttle sensor, temperature sensor, or oil level sensor.	

OIL LEVEL SENSOR

10. To exit the fluid level display mode:

- Pushbutton shift selector — press the N (Neutral) pushbutton or press ↑ and ↓ arrow pushbuttons simultaneously two times.
- Lever shift selector — press the “display mode” button two times or move the lever.

5-2. ELECTRONIC FLUID LEVEL CHECK (PRO-LINK® 9000)

The Pro-Link® 9000 (DDR) can also be used to electronically check the transmission’s fluid level. Further detail is also provided in Appendix N of this manual.

CAUTION:

A low or high fluid level causes overheating and irregular shift patterns and, if not corrected, can damage the transmission.

A. Fluid Level Check Procedure

1. Connect the DDR to the DDR connector.
2. Scroll (down) the Diagnostic Data List to “OIL LVL” display.
3. Read the fluid level, repeat the check to confirm the first reading.

NOTE: *The ECU may delay the fluid level check until the following conditions are met:*

- *The fluid temperature is between 60°C (140°F) and 104°C (220°F).*
- *The transmission is in N (Neutral).*
- *The vehicle has been stationary for approximately two minutes to allow the fluid to settle.*
- *The engine is at idle.*

The reason for a delayed fluid level check is indicated on the DDR by one of the following diagnostic messages:

Table 5-2.

DDR MESSAGE		
O L	—	SETTLING TIME (8 down to 1)
O L	—	ENGINE SPEED LO
O L	—	ENGINE SPEED HI
O L	—	SELECT N (NEUTRAL)
O L	—	SUMP TEMP LO
O L	—	SUMP TEMP HI
O L	—	OUTPUT SPEED HI
O L	—	CHECK CODES

OIL LEVEL SENSOR

NOTES

SECTION 6 — DIAGNOSTIC CODES

6-1. DIAGNOSTIC CODE MEMORY

Diagnostic codes are logged in a list in memory (sometimes referred to as the queue), listing the most recently occurring code first and logging up to five codes. The codes contained in the list have information recorded as shown in the table below (codes are examples). Access to the code list position, main code, subcode and active indicator is through either the shift selector display or the Pro-Link® diagnostic tool. Access to ignition cycle counter and event counter information is through the diagnostic tool only. Further detail on the use of Pro-Link® 9000 DDR is presented in Appendix N of this manual.

Table 6-1. Code List

Code List Position	Main Code	Subcode	Active Indicator	Ignition Cycle Counter	Event Counter
d1	21	12	YES	00	10
d2	41	12	YES	00	04
d3	23	12	NO	08	02
d4	34	12	NO	13	01
d5	56	11	NO	22	02
Displayed on shift selector and diagnostic tool d = "diagnostic"			YES = LED indicator illuminated	Not available on shift selector display	

The following paragraphs define the different parts of the code list.

- A. **Code List Position.** The position which a code occupies in the code list. Positions are displayed as "d1" through "d5" (Code List Position #1 through Code List Position #5).
- B. **Main Code.** The general condition or area of fault detected by the ECU.
- C. **Subcode.** The specific area or condition related to the main code in which a fault is detected.
- D. **Active Indicator.** Indicates when a diagnostic code is active. The MODE indicator LED on the shift selector is illuminated or the diagnostic tool displays **YES**.
- E. **Ignition Cycle Counter.** Determines when inactive diagnostic codes are automatically cleared from the code list. The counter is increased by one each time a normal ECU power down occurs (ignition turned off). Inactive codes are cleared from the code list after the counter exceeds 25.
- F. **Event Counter.** Counts the number of occurrences of a diagnostic code. If a code is already in the code list and the code is again detected, that code is moved to position d1, the active indicator is turned on, the Ignition Cycle Counter is cleared, and 1 is added to the Event Counter.

6-2. CODE READING AND CODE CLEARING

Diagnostic codes can be read and cleared by two methods: by using the Pro-Link® 9000 diagnostic tool or by entering the diagnostic display mode and using the shift selector display. The use of the Pro-Link® 9000 diagnostic tool is described in the instruction manual furnished with each tool and briefly in Appendix N of this manual. The method of reading and clearing codes described in this section refers to entering the diagnostic display mode by the proper button movements on the shift selector.

DIAGNOSTIC CODES

The diagnostic display mode may be entered for viewing of codes at any speed. Active codes can only be cleared when the output speed = 0 and no output speed sensor failure is active.

- A. Reading Codes.** Enter the diagnostic display mode by pressing the ↑ (Up) and ↓ (Down) arrow buttons at the same time on a pushbutton selector, or by momentarily pressing the “display mode” button on a lever shift selector.

NOTE: *If a DO NOT SHIFT condition is present (CHECK TRANS light illuminated) at this time, the shift selector may or may not respond to requested range changes.*

NOTE: *If an oil level sensor is present, then fluid level will be displayed first. Diagnostic code display is achieved by simultaneously depressing the ↑ (Up) and ↓ (Down) arrow buttons a second time or the “display mode” button a second time.*

The code list or queue position is the first item displayed, followed by the main code and the subcode. Each item is displayed for about one second. The display cycles continuously until the next code list position is accessed by pressing the **MODE** button. The following list represents the display cycle using code 25 11 as an example:

1. Code list position — **d, 1**
2. Main code — **2, 5**
3. Subcode — **1, 1**
4. Cycle repeats — **d, 1, 2, 5, 1, 1**

To view the second, third, fourth, and fifth positions (d2, d3, d4, and d5), momentarily press the **MODE** button as explained above.

Momentarily press the **MODE** button after the fifth position is displayed to restart the sequence of code list positions.

An active code is indicated by the illumination of the LED indicator when a code position is displayed while in the diagnostic display mode. In the normal operating mode, the LED indicator illuminates to show a secondary mode operation.

Any code position which does not have a diagnostic code logged will display “-” for both the main and subcodes. No diagnostic codes are logged after an empty code position.

- B. Clearing Active Indicators.** A diagnostic code’s active indicator can be cleared, which allows the code inhibit to be cleared but remains in the queue as inactive.

The active indicator clearing methods are:

1. Power down — All active indicators, except code 69 34 (refer to the code chart), are cleared at ECU power down.
2. Self-clearing — Some codes will clear their active indicator when the condition causing the code is no longer detected by the ECU.

DIAGNOSTIC CODES

3. Manual — Some active indicators can be cleared manually, while in the diagnostic display mode, after the condition causing the code is corrected.

CAUTION: If an active indicator is cleared while the transmission is locked in a forward range or reverse (fail-to-range), the transmission will remain in the forward range or reverse after the clearing procedure is completed. Neutral must be manually selected.

- C. Manually Clearing Codes and Active Indicators from the Code List.** To clear active indicators or all codes:
1. Enter the diagnostic display mode.
 2. Press and hold the **MODE** button for approximately three seconds until the LED indicator flashes. All active indicators are cleared. To remove all inactive codes, press and hold the **MODE** button for about ten seconds until the LED indicator flashes again. All active indicators will be cleared at ECU power down.
 3. Codes that cannot be manually cleared will remain.
- D. Exiting the diagnostic display mode.** Exit the diagnostic display mode using one of the following procedures:
1. On a pushbutton shift selector, press the \uparrow (Up) and \downarrow (Down) arrow buttons at the same time or press any range button, **D**, **N**, or **R**. The shift (**D**, **N**, or **R**) is commanded if not inhibited by an active code.
 2. On a lever shift selector, momentarily press the "display mode" button or move the shift lever to any shift position other than the one it was in when the diagnostic display mode was activated. If the shift is inhibited, the ECU will continue to command the current transmission range attained and the lever should be returned to its original position.
 3. Wait until timeout (approximately 10 minutes) and the system will automatically return to the normal operating mode.
 4. Turn off power to the ECU (turn off the vehicle engine at the ignition switch).

6-3. DIAGNOSTIC CODE RESPONSE

The following ECU responses to a fault provide for safe transmission operation:

- **Do Not Shift (DNS) Response**
 - Release lockup clutch and inhibit lockup operation.
 - Inhibit all shifts.
 - Turn on the **CHECK TRANS** light.
 - Display the range attained.
 - Ignore any range selection inputs from the pushbutton or lever shift selector.
- **Do Not Adapt (DNA) Response**
 - The ECU stops adaptive shift control while the code is active. Do not adapt shifts when a code with the DNA response is active.

DIAGNOSTIC CODES

- **SOLenoid OFF (SOL OFF) Response**
 - All solenoids are commanded off (turning solenoids “A” and “B” off electrically causes them to be on hydraulically).
- **Return to Previous Range (RPR) Response**
 - When the speed sensor ratio or C3 pressure switch tests associated with a shift are not successful, the ECU commands the same range as commanded before the shift.
- **Neutral No Clutches (NNC) Response**
 - When certain speed sensor ratio or C3 pressure switch tests are not successful, the ECU commands a neutral condition with no clutches applied.

6-4. SHIFT SELECTOR DISPLAYS RELATED TO ACTIVE CODES

- “Cateye” — The forward slash segments and the middle horizontal segments (-\-) may be on under the following conditions:
 - RSI link fault is active (code 23 12 or 23 14)
 - When two COP timeouts occur within two seconds of each other (reference code 69 33)
 - Shift selector display line fault is active (23 16)
- All Segments Displayed — All display segments will be illuminated if a severity 1 diagnostic code is present during initialization, or if an electrical code for solenoids A, B, C, D, E, OR G is logged before initialization completes.

6-5. DIAGNOSTIC CODE LIST AND DESCRIPTION

Table 6-2. WT Series Diagnostic Codes

Main Code	Subcode	Description	CHECK TRANS Light	Inhibited Operation Description
13	12	ECU input voltage, low	Yes	DNS, DNA, SOL OFF (hydraulic default)
	13	ECU input voltage, medium low	No	DNA
	23	ECU input voltage, high	Yes	DNS, SOL OFF (hydraulic default)
14	12	Oil level sensor, failed low	No	None
	23	Oil level sensor, failed high	No	None
21	12	Throttle position sensor, failed low	No	Use throttle default values, DNA
	23	Throttle position sensor, failed high	No	Use throttle default values, DNA
22	14	Engine speed sensor reasonableness test	No	Use default engine speed, DNA
	15	Turbine speed sensor reasonableness test	Yes	DNS, lock in current range, DNA
	16	Output speed sensor reasonableness test	Yes ⁽¹⁾	DNS, lock in current range, DNA

DIAGNOSTIC CODES

Table 6-2. WT Series Diagnostic Codes (cont'd)

Main Code	Subcode	Description	CHECK TRANS Light	Inhibited Operation Description
23	12	Primary shift selector or RSI link fault	No	Hold in last valid direction. May cause "cateye" display.
	13	Primary shift selector mode function fault	No	Mode change not permitted
	14	Secondary shift selector or RSI link fault	No	Hold in last valid direction. May cause "cateye" display.
	15	Secondary shift selector mode function fault	No	Mode change not permitted
	16	Shift Selector display line fault	No	None. May cause "cateye" display.
24	12	Sump fluid temperature, cold	Yes	DNS, lock in neutral
	23	Sump fluid temperature, hot	No	No upshifts above a calibration range
25	00	Output speed sensor, detected at 0 output rpm, Low	Yes ⁽¹⁾	DNS, lock in current range (Low), DNA
	11	Output speed sensor, detected at 0 output rpm, 1st	Yes ⁽¹⁾	DNS, lock in current range (1st), DNA
	22	Output speed sensor, detected at 0 output rpm, 2nd	Yes ⁽¹⁾	DNS, lock in current range (2nd), DNA
	33	Output speed sensor, detected at 0 output rpm, 3rd	Yes ⁽¹⁾	DNS, lock in current range (3rd), DNA
	44	Output speed sensor, detected at 0 output rpm, 4th	Yes ⁽¹⁾	DNS, lock in current range (4th), DNA
	55	Output speed sensor, detected at 0 output rpm, 5th	Yes ⁽¹⁾	DNS, lock in current range (5th), DNA
	66	Output speed sensor, detected at 0 output rpm, 6th	Yes ⁽¹⁾	DNS, lock in current range (6th), DNA
26	00	Throttle source not detected	No	Use throttle default values, DNA
	11	Engine coolant source not detected	No	Use default value of -18°C (0°F)
32	00	C3 pressure switch open, Low range	Yes	DNS, lock in current range (Low), DNA
	33	C3 pressure switch open, 3rd range	Yes	DNS, lock in current range (3rd), DNA
	55	C3 pressure switch open, 5th range	Yes	DNS, lock in current range (5th), DNA
	77	C3 pressure switch open, Reverse range	Yes	DNS, lock in current range (R), DNA
33	12	Sump oil temperature sensor failed low	No	Use default value of 93°C (200°F)
	23	Sump oil temperature sensor failed high	No	Use default value of 93°C (200°F)

DIAGNOSTIC CODES

Table 6-2. WT Series Diagnostic Codes (cont'd)

Main Code	Subcode	Description	CHECK TRANS Light	Inhibited Operation Description
34	12	Factory calibration compatibility number wrong	Yes ⁽⁵⁾	DNS, SOL OFF (hydraulic default), DNA
	13	Factory calibration block checksum	Yes ⁽⁵⁾	DNS, SOL OFF (hydraulic default), DNA
	14	Power off block checksum	No	Use previous location, or factory calibration and reset adaptive, DNA
	15	Diagnostic queue block checksum	No	Use previous location, or clear diagnostic queue, DNA
	16	Real time block checksum	Yes	DNS, SOL OFF (hydraulic default), DNA
	17	Customer modifiable constants checksum	Yes ⁽⁵⁾	DNS, SOL OFF (hydraulic default), DNA
35	00	Power interruption (code set after power restored)	No	None (hydraulic default during interruption)
	16	Real time write interruption	Yes	DNS, SOL OFF (hydraulic default), DNA
36	00	Hardware/software not compatible	Yes ⁽²⁾	DNS, SOL OFF (hydraulic default), DNA
	01	TID not compatible with hardware/software	No ⁽²⁾	Use TIDCAP cal
	02	TID did not complete	No	Use TIDCAP cal, code 42 XX or 69 XX may be logged
42	12	Short-to-battery, A solenoid circuit	Yes	DNS, SOL OFF, DNA
	13	Short-to-battery, B solenoid circuit	Yes	DNS, SOL OFF, DNA
	14	Short-to-battery, C solenoid circuit	Yes	DNS, SOL OFF, DNA
	15	Short-to-battery, D solenoid circuit	Yes	DNS, SOL OFF, DNA
	16	Short-to-battery, E solenoid circuit	Yes	DNS, SOL OFF, DNA
	21	Short-to-battery, F solenoid circuit	No	Lockup inhibited, DNA
	22	Short-to-battery, G solenoid circuit	Yes	DNS, SOL OFF, DNA
	23	Short-to-battery, H solenoid circuit	No	Differential lock inhibited (3070 only), retarder inhibited
	24	Short-to-battery, J solenoid circuit	No	Low and 1st inhibited
26	Short-to-battery, N solenoid circuit	No	Low and 1st inhibited, allow retarder	
44	12	Short-to-ground, A solenoid circuit	Yes	DNS, SOL OFF (hydraulic default), DNA
	13	Short-to-ground, B solenoid circuit	Yes	DNS, SOL OFF (hydraulic default), DNA
	14	Short-to-ground, C solenoid circuit	Yes	DNS, SOL OFF (hydraulic default), DNA
	15	Short-to-ground, D solenoid circuit	Yes	DNS, SOL OFF (hydraulic default), DNA
	16	Short-to-ground, E solenoid circuit	Yes	DNS, SOL OFF (hydraulic default), DNA
	21	Short-to-ground, F solenoid circuit	No	Lockup inhibited, DNA
	22	Short-to-ground, G solenoid circuit	Yes	DNS, SOL OFF (hydraulic default), DNA

DIAGNOSTIC CODES

Table 6-2. WT Series Diagnostic Codes (cont'd)

Main Code	Subcode	Description	CHECK TRANS Light	Inhibited Operation Description
44 (cont'd)	23	Short-to-ground, H solenoid circuit	No	Differential lock inhibited (3070 only), retarder operation inhibited
	24	Short-to-ground, J solenoid circuit	No	Low and 1st inhibited
	26	Short-to-ground, N solenoid circuit	No	Low and 1st inhibited, retarder allowed
45	12	Open circuit, A solenoid circuit	Yes	DNS, SOL OFF (hydraulic default), DNA
	13	Open circuit, B solenoid circuit	Yes	DNS, SOL OFF (hydraulic default), DNA
	14	Open circuit, C solenoid circuit	Yes	DNS, SOL OFF (hydraulic default), DNA
	15	Open circuit, D solenoid circuit	Yes	DNS, SOL OFF (hydraulic default), DNA
	16	Open circuit, E solenoid circuit	Yes	DNS, SOL OFF (hydraulic default), DNA
	21	Open circuit, F solenoid circuit	No	Lockup inhibited, DNA
	22	Open circuit, G solenoid circuit	Yes	DNS, SOL OFF (hydraulic default), DNA
	23	Open circuit, H solenoid circuit	No	Differential lock inhibited (3070 only), retarder inhibited
	24	Open circuit, J solenoid circuit	No	Low and 1st inhibited
26	Open circuit, N solenoid circuit	No	Low and 1st inhibited, retarder allowed	
46	21	Overcurrent, F solenoid circuit	No	Lockup inhibited, DNA
	26	Overcurrent, N and H solenoid circuit	No	Low and first inhibited or retarder inhibited, DNA
	27	Overcurrent, A-Hi solenoid circuit	Yes	DNS, SOL OFF (hydraulic default), DNA
51	01	Offgoing ratio test (during shift), Low to 1	Yes	DNS, RPR, DNA
	10	Offgoing ratio test (during shift), 1 to Low	Yes	DNS, RPR, DNA
	12	Offgoing ratio test (during shift), 1 to 2	Yes	DNS, RPR, DNA
	21	Offgoing ratio test (during shift), 2 to 1	Yes	DNS, RPR, DNA
	23	Offgoing ratio test (during shift), 2 to 3	Yes	DNS, RPR, DNA
	24	Offgoing ratio test (during shift), 2 to 4	Yes	DNS, RPR, DNA
	35	Offgoing ratio test (during shift), 3 to 5	Yes	DNS, RPR, DNA
	42	Offgoing ratio test (during shift), 4 to 2	Yes	DNS, RPR, DNA
	43	Offgoing ratio test (during shift), 4 to 3	Yes ⁽¹⁾	DNS, RPR, DNA
45	Offgoing ratio test (during shift), 4 to 5	Yes ⁽¹⁾	DNS, RPR, DNA	

DIAGNOSTIC CODES

Table 6-2. WT Series Diagnostic Codes (cont'd)

Main Code	Subcode	Description	CHECK TRANS Light	Inhibited Operation Description
51 (cont'd)	46	Offgoing ratio test (during shift), 4 to 6	Yes	DNS, RPR, DNA
	53	Offgoing ratio test (during shift), 5 to 3	Yes	DNS, RPR, DNA
	64	Offgoing ratio test (during shift), 6 to 4	Yes	DNS, RPR, DNA
	65	Offgoing ratio test (during shift), 6 to 5	Yes	DNS, RPR, DNA
	XY	Offgoing ratio test, X to Y ⁽³⁾		
52	01	Offgoing C3PS test (during shift), Low to 1	Yes	DNS, RPR, DNA
	08	Offgoing C3PS test (during shift), Low to N1	Yes	DNS, NNC, DNA
	32	Offgoing C3PS test (during shift), 3 to 2	Yes	DNS, RPR, DNA
	34	Offgoing C3PS test (during shift), 3 to 4	Yes	DNS, RPR, DNA
	54	Offgoing C3PS test (during shift), 5 to 4	Yes	DNS, RPR, DNA
	56	Offgoing C3PS test (during shift), 5 to 6	Yes	DNS, RPR, DNA
	71	Offgoing C3PS test (during shift), R to 1	Yes	DNS, NNC, DNA
	72	Offgoing C3PS test (during shift), R to 2	Yes	DNS, NNC, DNA
	78	Offgoing C3PS test (during shift), R to N1	Yes	DNS, NNC, DNA
	99	Offgoing C3PS test (during shift), N3 to N2	Yes	DNS, RPR, DNA
XY	Offgoing C3PS test, X to Y ⁽³⁾			
53	08	Offgoing speed test (during shift), L to N1	Yes ⁽¹⁾	DNS, NNC, DNA
	18	Offgoing speed test (during shift), 1 to N1	Yes ⁽¹⁾	DNS, NNC, DNA
	28	Offgoing speed test (during shift), 2 to N1	Yes ⁽¹⁾	DNS, NNC, DNA
	29	Offgoing speed test (during shift), 2 to N2	Yes ⁽¹⁾	DNS, RPR, DNA
	38	Offgoing speed test (during shift), 3 to N1	Yes ⁽¹⁾	DNS, NNC, DNA

DIAGNOSTIC CODES

Table 6-2. WT Series Diagnostic Codes (cont'd)

Main Code	Subcode	Description	CHECK TRANS Light	Inhibited Operation Description
53 (cont'd)	39	Offgoing speed test (during shift), 3 to N3	Yes ⁽¹⁾	DNS, RPR, DNA
	48	Offgoing speed test (during shift), 4 to N1	Yes ⁽¹⁾	DNS, NNC, DNA
	49	Offgoing speed test (during shift), 4 to N3	Yes ⁽¹⁾	DNS, RPR, DNA
	58	Offgoing speed test (during shift), 5 to N1	Yes ⁽¹⁾	DNS, NNC, DNA
	59	Offgoing speed test (during shift), 5 to N3	Yes ⁽¹⁾	DNS, RPR, DNA
	68	Offgoing speed test (during shift), 6 to N1	Yes ⁽¹⁾	DNS, NNC, DNA
	69	Offgoing speed test (during shift), 6 to N4	Yes ⁽¹⁾	DNS, RPR, DNA
	78	Offgoing speed test (during shift), R to N1	Yes	DNS, NNC, DNA
	99	Offgoing speed test (during shift), N2 to N3 or N3 to N2	Yes	DNS, RPR, DNA
	XY	Offgoing speed test (during shift), X to Y ⁽³⁾		
54	01	Oncoming ratio test (after shift), L to 1	Yes	DNS, RPR, DNA
	07	Oncoming ratio test (after shift), L to R	Yes	DNS, NNC, DNA
	10	Oncoming ratio test (after shift), 1 to L	Yes	DNS, RPR, DNA
	12	Oncoming ratio test (after shift), 1 to 2	Yes	DNS, RPR, DNA
	17	Oncoming ratio test (after shift), 1 to R	Yes	DNS, NNC, DNA
	21	Oncoming ratio test (after shift), 2 to 1	Yes	DNS, RPR, DNA
	23	Oncoming ratio test (after shift), 2 to 3	Yes	DNS, RPR, DNA
	24	Oncoming ratio test (during shift), 2 to 4	Yes	DNS, RPR, DNA
	27	Oncoming ratio test (after shift), 2 to R	Yes	DNS, RPR, DNA
	32	Oncoming ratio test (after shift), 3 to 2	Yes	DNS, RPR, DNA
	34	Oncoming ratio test (after shift), 3 to 4	Yes	DNS, RPR, DNA

DIAGNOSTIC CODES

Table 6-2. WT Series Diagnostic Codes (cont'd)

Main Code	Subcode	Description	CHECK TRANS Light	Inhibited Operation Description
54 (cont'd)	35	Oncoming ratio test (during shift), 3 to 5	Yes	DNS, RPR, DNA
	42	Oncoming ratio test (during shift), 4 to 2	Yes	DNS, RPR, DNA
	43	Oncoming ratio test (after shift), 4 to 3	Yes	DNS, RPR, DNA
	45	Oncoming ratio test (after shift), 4 to 5	Yes	DNS, RPR or SOL OFF (hydraulic default), DNA
	46	Oncoming ratio test (during shift), 4 to 6	Yes	DNS, RPR, DNA
	53	Oncoming ratio test (during shift), 5 to 3	Yes	DNS, RPR, DNA
	54	Oncoming ratio test (after shift), 5 to 4	Yes	DNS, RPR, DNA
	56	Oncoming ratio test (after shift), 5 to 6	Yes	DNS, RPR, DNA
	64	Oncoming ratio test (after shift), 6 to 4	Yes	DNS, RPR, DNA
	65	Oncoming ratio test (after shift), 6 to 5	Yes	DNS, RPR, DNA
	70	Oncoming ratio test (after shift), R to L	Yes	DNS, NNC, DNA
	71	Oncoming ratio test (after shift), R to 1	Yes	DNS, NNC, DNA
	72	Oncoming ratio test (after shift), R to 2	Yes	DNS, NNC, DNA
	80	Oncoming ratio test (after shift), N1 to L	Yes	DNS, RPR, DNA
	81	Oncoming ratio test (after shift), N1 to 1	Yes	DNS, RPR, DNA
	82	Oncoming ratio test (after shift), N1 to 2	Yes	DNS, RPR, DNA
	83	Oncoming ratio test (after shift), N1 to 3	Yes	DNS, RPR, DNA
	85	Oncoming ratio test (after shift), N1 to 5	Yes	DNS, RPR, DNA
	86	Oncoming ratio test (after shift), N1 to 6	Yes	DNS, RPR, DNA
	92	Oncoming ratio test (after shift), N2 to 2	Yes	DNS, RPR, DNA

DIAGNOSTIC CODES

Table 6-2. WT Series Diagnostic Codes (cont'd)

Main Code	Subcode	Description	CHECK TRANS Light	Inhibited Operation Description
54 (cont'd)	93	Oncoming ratio test (after shift), N3 to 3	Yes	DNS, RPR, DNA
	95	Oncoming ratio test (after shift), N3 to 5	Yes	DNS, RPR, DNA
	96	Oncoming ratio test (after shift), N4 to 6	Yes	DNS, RPR, DNA
	XY	Oncoming ratio test (after shift), X to Y ⁽³⁾		
55	07	Oncoming C3PS test (after shift), Low to R	Yes ⁽¹⁾	DNS, NNC, DNA
	17	Oncoming C3PS test (after shift), 1 to R	Yes ⁽¹⁾	DNS, NNC, DNA
	27	Oncoming C3PS test (after shift), 2 to R	Yes ⁽¹⁾	DNS, NNC, DNA
	87	Oncoming C3PS test (after shift), N1 to R	Yes	DNS, RPR, DNA
	97	Oncoming C3PS test (after shift), NVL to R	Yes ⁽¹⁾	DNS, NNC, DNA
	XY	Oncoming C3PS test (after shift), X to Y ⁽³⁾		
56	00	Range verification test, L	Yes ⁽¹⁾	DNS, 1st, Low, or SOL OFF (Low), DNA
	11	Range verification ratio test, 1st	Yes	DNS, 6th, DNA
	22	Range verification ratio test, 2nd	Yes ⁽¹⁾	DNS, 6th or 5th, DNA
	33	Range verification ratio test, 3rd	Yes ⁽¹⁾	DNS, 5th or SOL OFF (4th), DNA
	44	Range verification ratio test, 4th	Yes	DNS, 3rd or 5th, DNA
	55	Range verification ratio test, 5th	Yes ⁽¹⁾	DNS, SOL OFF (5th) or 3rd, DNA
	66	Range verification ratio test, 6th	Yes	DNS, 5th, 3rd, or SOL OFF (3rd), DNA
	77	Range verification ratio test, R	Yes	DNS, N2 or N3, DNA
57	11	Range verification C3PS test, 1st	Yes	DNS, SOL OFF (3rd), DNA
	22	Range verification C3PS test, 2nd	Yes	DNS, 3rd, DNA
	44	Range verification C3PS test, 4th	Yes	DNS, 5th or SOL OFF (3rd), DNA
	66	Range verification C3PS test, 6th	Yes	DNS, SOL OFF (5th), DNA
	88	Range verification C3PS test, N1	Yes	DNS, N3, DNA
	99	Range verification C3PS test, N2 or N4	Yes	DNS, N3, DNA
61	00	Retarder oil temperature, hot	No	None

DIAGNOSTIC CODES

Table 6-2. WT Series Diagnostic Codes (cont'd)

Main Code	Subcode	Description	CHECK TRANS Light	Inhibited Operation Description
62	12	Retarder temperature sensor failed low	No	None
	23	Retarder temperature sensor failed high	No	None
	32	Engine coolant sensor failed low	No	Use default value of 0°F
	33	Engine coolant sensor failed high	No	Use default value of 0°F
63	00	Input function fault	No	Does not prevent neutral to range shifts for Aux Function Range Inhibit-Special when two signals required are not "on" within 120 seconds of each other.
	26	Kickdown input failed on	No	Kickdown operation inhibited
	40	Service brake status input failed on	No	No auto Neutral to Drive shifts for refuse packer. (I/O package #41). No retarder if a TPS code is also active
	41	Pump/pack and a neutral general purpose input	No	No auto N-D shifts for refuse packer (I/O package #41)
64	12	Retarder modulation request sensor failed low	No	Retarder operation inhibited
	23	Retarder modulation request sensor failed high	No	Retarder operation inhibited
		Engine rating too high	Yes	DNS, Lock-in-neutral, DNA
66	00	Serial communications interface fault	No	Use default throttle values, DNA
	11	SCI engine coolant source fault	No	Use default value of 0°F
69	27	ECU, inoperative A-Hi switch	Yes	DNS, NNC, DNA
	28	ECU, inoperative F-Hi switch	Yes	Lockup inhibited, DNA
	29	ECU, inoperative N and H-Hi switch	No	Low and first inhibited, retarder inhibited, DNA
	33	ECU, Computer Operating Properly (COP) timeout	No	Reset ECU, shutdown ECU on 2nd occurrence (power loss; hydraulic defaults). May cause "cateye" display or all segments blank display, DNA ⁽⁴⁾
	34	ECU, write timeout	Yes	DNS, SOL OFF (hydraulic default), DNA
	35	ECU, checksum test	No	Induce COP timeout (reset ECU), DNA ⁽⁴⁾
	36	ECU, RAM self test	No	Induce COP timeout (reset ECU), DNA ⁽⁴⁾
	39	Communication chip addressing error	No	Use defaults for J1939 data, DNA
	41	ECU, I/O ASIC addressing test	No	Induce COP timeout (reset ECU), DNA ⁽⁴⁾
42	SPI output failure	Yes	GPO 1-8 and reverse warning inoperable	
43	SPI input failure	Yes	DNS, lock-in-range, DNA	

DIAGNOSTIC CODES

Table 6-2. WT Series Diagnostic Codes (*cont'd*)

Main Code	Subcode	Description	CHECK TRANS Light	Inhibited Operation Description
70	12	Software, minor loop overrun	No	Induce COP timeout (reset ECU)
	13	Illegal write to address \$0000	No	Induce COP timeout (reset ECU)
	14	Software, major loop overrun	No	Induce COP timeout (reset ECU)

NOTES

- (1) This code is logged to real time to protect the transmission in case a loss of power to the ECU (Power Interruption, code 35 00) occurs.
- (2) The ECU hardware or software must be changed so that they are compatible.
- (3) Additional codes could be logged for other shifts where X indicates range shifted from and Y indicates range shifted to.
- (4) The COP reset will clear the active inhibit.
- (5) The factory calibration must be rewritten to the ECU, or a different factory calibration is required to match the software in the ECU.

DIAGNOSTIC CODES

NOTES

TRANSMISSION COMPONENT WIRING DIAGRAMS AND DIAGNOSTICS

DIAGNOSTIC CODES

NOTES

DIAGNOSTIC CODES

6-6. DIAGNOSTIC CODE TROUBLESHOOTING

A. Beginning The Troubleshooting Process

1. Begin troubleshooting by checking the transmission fluid level and ECU input voltage. Check diagnostic codes by:
 - Using the shift selector display.
 - Using the Pro-Link® 9000 diagnostic tool.
2. When a problem exists but a diagnostic code is not indicated, refer to the Performance Complaint Section for a listing of various electrical and hydraulic problems, their causes, and remedies.
3. If a diagnostic code is found in the ECU memory, record all available code information and clear the active indicator (refer to Paragraph 6-2).
4. Test drive the vehicle to confirm a diagnostic code or performance complaint.
 - If the code reappears, refer to the Diagnostic Code section (Section 6) and the appropriate code chart. The Diagnostic Code section lists diagnostic codes and their description. Locate the appropriate troubleshooting chart and follow the instructions.
 - If the code does not reappear, it may be an intermittent problem. Use the Pro-Link® and the code display procedure described in Section 6. The code display procedure will indicate the number of times the diagnostic code has occurred. Refer to the troubleshooting chart for possible cause(s) of the problem.
 - Appendix A deals with the identification of potential circuit problems. Refer to Appendix A if a circuit problem is suspected.

NOTE: *Information concerning specific items is contained in the appendices located in the back of this manual. The appendices are referred to throughout the manual.*

B. Solenoid Locations

Solenoid locations in the control module are as illustrated in Figure 6-1. Refer to Figure 6-1 as necessary when using the diagnostic code schematics.

C. Diagnostic Code Schematics

The diagnostic code schematics in this section show wiring for both the optional oil level sensor and retarder, where applicable. If your transmission is not equipped with an oil level sensor or retarder, disregard the portions of the schematic pertaining to those optional pieces of equipment. Refer to the appropriate transmission Service Manual for solenoid replacement procedures.

D. Wire/Terminal Numbering Scheme

WTEC III wire identification presents the wire number followed by the ECU terminal source (i.e., 157-S30). This is done to retain the wire number/function assignments from WTEC II and indicate the ECU connector and terminal origination for WTEC III. If there is a letter suffix following the wire number, there is a splice between the ECU source and wire destination (i.e., 136A-S16).

DIAGNOSTIC CODES

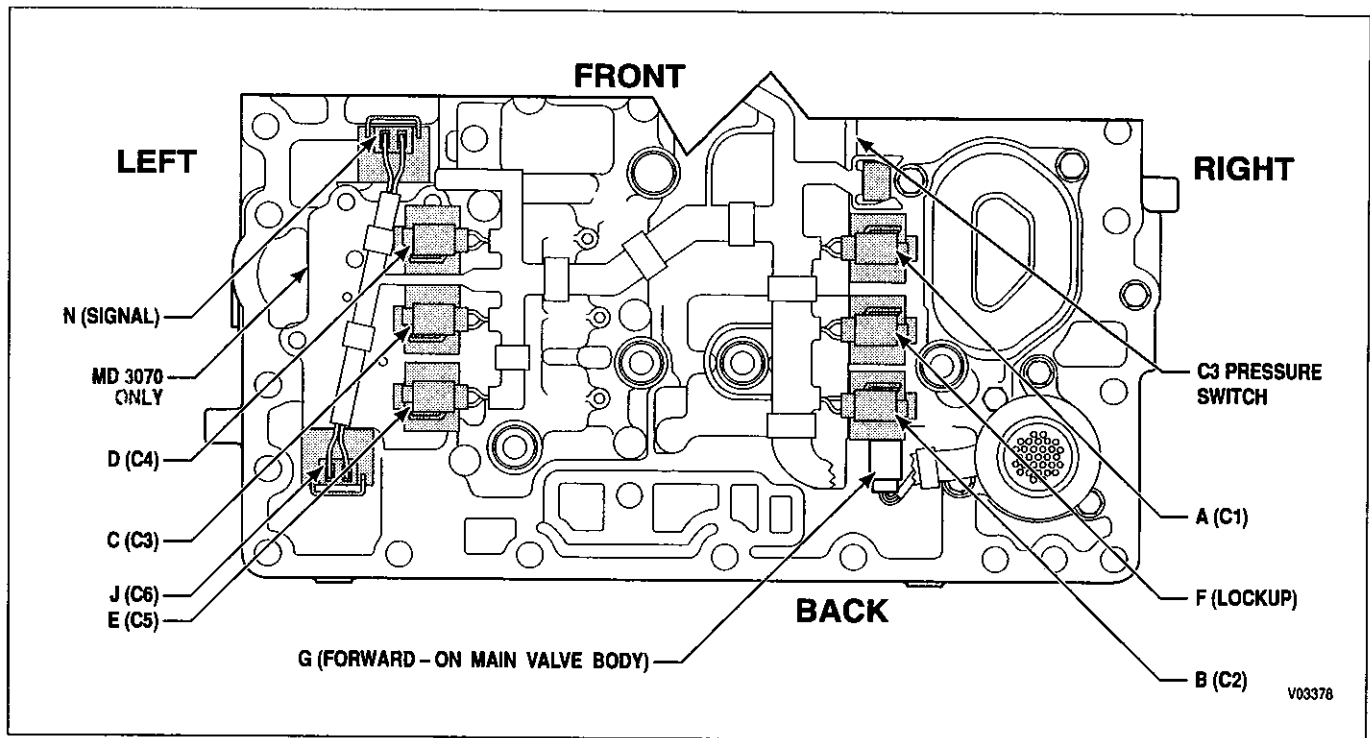
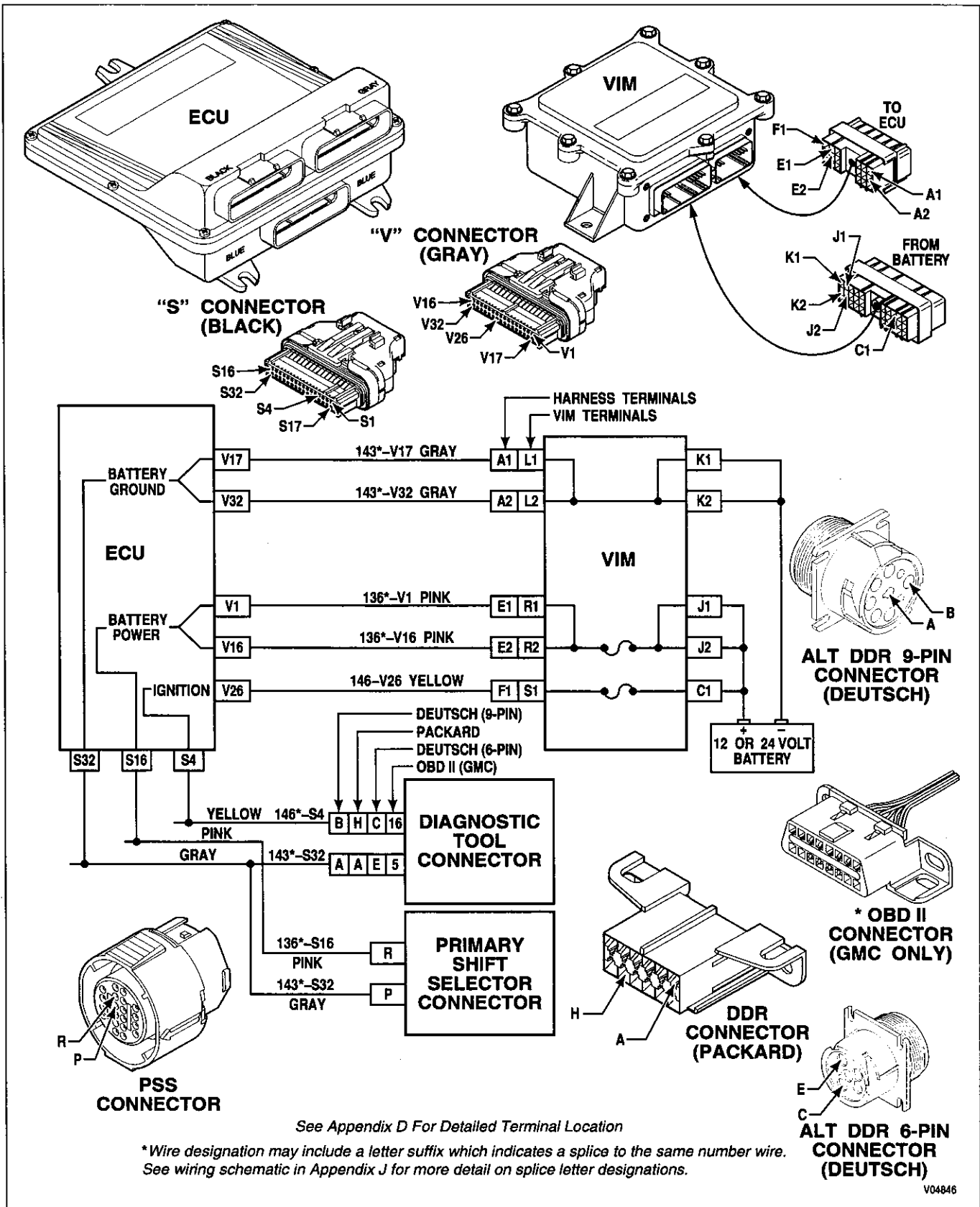

Figure 6-1. Control Module Solenoid Location

DIAGNOSTIC CODES

NOTES

CODE 13 XX — ECU INPUT VOLTAGE



See Appendix D For Detailed Terminal Location

*Wire designation may include a letter suffix which indicates a splice to the same number wire. See wiring schematic in Appendix J for more detail on splice letter designations.

V04846

Figure 6-2. Code 13 Schematic Drawing

CODE 13 XX — ECU INPUT VOLTAGE (Figure 6-2)

Main code 13 indicates either a high or low input voltage. Low voltage is less than 8 volts. High voltage is over 33 volts.

Common causes for a low voltage code are:

- Bad batteries
- Faulty vehicle charging system
- No dedicated power and ground connection directly to the battery or through an electronic bus bar to the battery

Common causes for the high voltage code are:

- Faulty vehicle alternator
- Faulty vehicle voltage regulator

In the event of a power loss, the transmission fails to the ranges indicated in the following, depending upon which latch valve releases first:

Attained Range	Fail to Range
Reverse and neutral	Neutral
Low, 1	3C
2, 3, 4	4C usually, 3C sometimes
5	4C usually, 5C sometimes
6	5C

Main Code	Subcode	Meaning
13	12	Battery voltage to the ECU too low
13	13	Battery voltage to the ECU too low (medium)
13	23	Battery voltage to the ECU too high

A. Active Indicator Clearing Procedure:

- Power down
- Manual
- Self-clearing

B. Troubleshooting:

1. Connect the diagnostic tool and turn on vehicle ignition. Select Diagnostic Data to find input voltage. Record reading.
2. Turn off vehicle ignition and remove the connectors from the ECU.
3. Check system voltage at wire 136A and 136C, pin V1 and V16. If power is low or high at this point, and the diagnostic tool reading is also low or high, the vehicle wiring is suspect. Check for fuse problems, lack of battery-direct power and ground, faulty charging system/batteries, and loose or dirty connections (see Appendix A). Power may also be low or high at pins V1 and V16 (system power) if the batteries/charging system is faulty. Bad grounds may also cause incorrect input power readings.

CODE 13 XX — ECU INPUT VOLTAGE (Figure 6-2)

4. If power is correct but the diagnostic tool reading indicates incorrect voltage, closely inspect terminals V1 and V16 or S16; make sure they are not corroded or deformed. Clean or replace as necessary (see Appendix E, Paragraph 1-1).
5. If the voltage condition is intermittent, closely inspect the vehicle wiring for transmission system power and grounds. Check for loose, dirty, or painted connections. Check the VIM for loose, incorrect, or overheating relays or fuses (refer to Appendix G). Check for wires that are chafed and touching other components.
6. If no other cause is found, replace the ECU. If replacing the ECU corrects the problem, reinstall the original (bad) ECU to confirm that the problem is in the ECU. If the original ECU now works, inspect the ECU connectors for any corrosion or damage which may cause an intermittent condition. If the original problem recurs, reinstall the replacement ECU.

Table 6-3. Voltage Chart

Voltage	Condition
33.0 (High Set Point)	High Fail Limit
32.0	Maximum Continuous ECU Voltage
10.0 (Medium Low Set Point)	Cannot Compensate With Sub-Modulation (Bad Shifts). Adaptive logic stops functioning
8.0	Low Voltage Fail Limit, Set Code, DNS
7.0 (Low Set Point)	Software Off (ECU loses power)
4.5	Neutral Start Off

DIAGNOSTIC CODES

NOTES

CODE 14 XX — OIL LEVEL SENSOR (OLS)

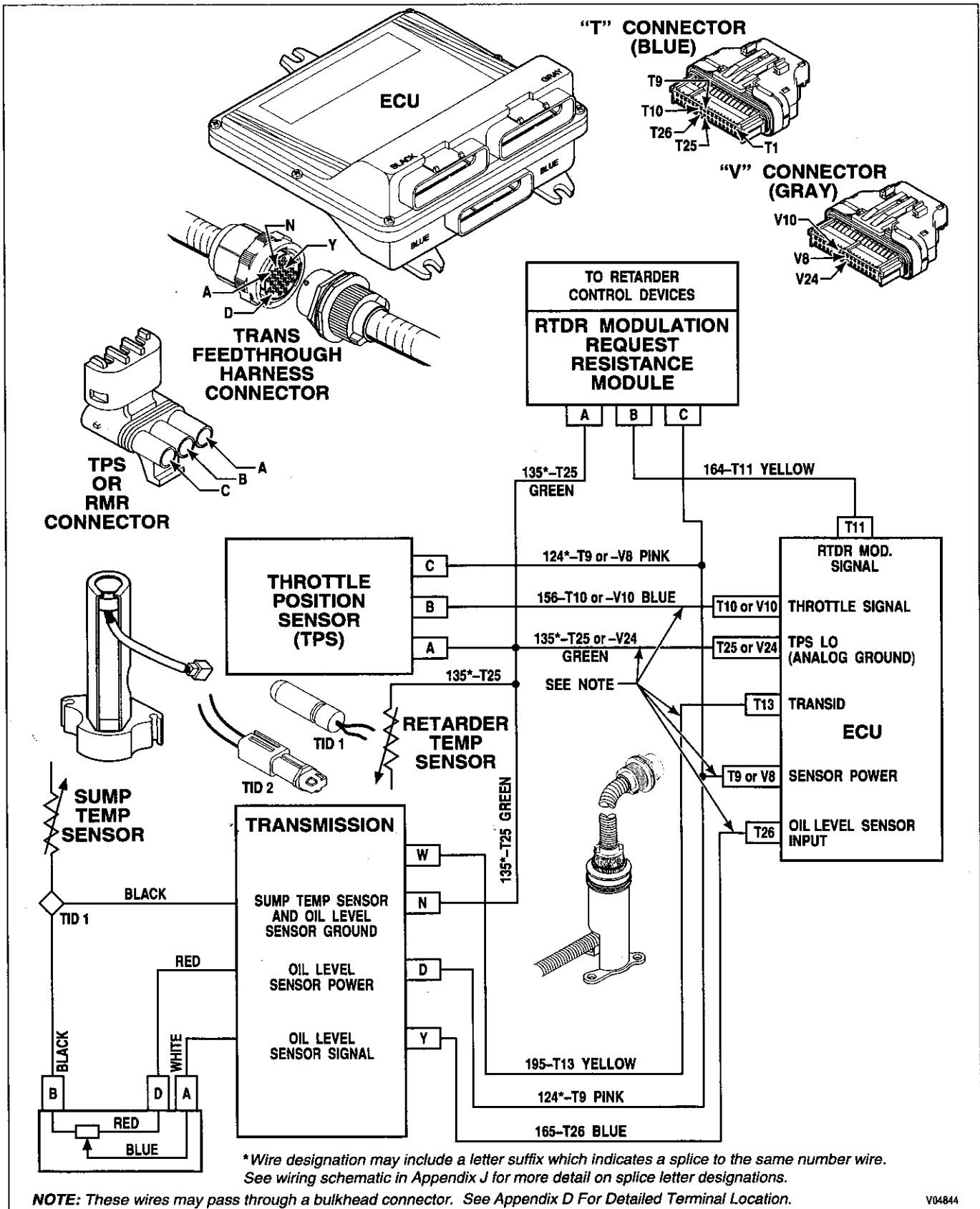

Figure 6-3. Code 14 Schematic Drawing

CODE 14 XX — OIL LEVEL SENSOR (OLS) (Figure 6-3)

The oil level sensor (OLS) must have been recognized by autodetect or manually selected using the Pro-Link® (see WTEC III Pro-Link® Manual) before these codes can be logged. See Paragraph 1-9 for further information.

Code 14 12 indicates the ECU has detected a voltage signal in the low error zone.

Code 14 12 can be caused by:

- Faulty wiring to the OLS
- A faulty OLS
- A faulty ECU

CAUTION: Never use a volt/ohmmeter to measure any parameters on the OLS. Damage to the OLS will result.

OLS ground wire 135B is common to the TPS and the RMR devices. A power wire short-to-ground for any of these devices will cause “sensor failed low” codes (21 12 and 64 12) and shutdown of the electrojic pushbutton or lever selector. An OLS signal open or short-to-ground results in a code 14 12 only. Code 14 23 is programmed out of all calibrations.

A permanent maximum voltage signal generates a steady OLS sensor maximum count and a maximum fluid level overfill indication. A maximum overfill indication occurs if signal wire 165 or power wire 124 is shorted to battery or the ground wire (wire 135) is open between the OLS and the sump temperature sensor branch. An open in the ground circuit wire 135 in the portion common to the OLS, TPS and RMR devices results in code 14 12, 21 23, and 64 23.

If the ECU software supports it, Oil Level Sensor counts can be read by a DDR with Pro-Link® version 3.0 (or later). For a complete description of fluid level checking procedures using the oil level sensor, see Section 5. Normal operation of the OLS can be checked as follows: Attach the DDR and display OIL LEVEL COUNTS. Read the number of counts when the engine is not running, but the ignition is ON. The count reading should be near 255. Start the engine and observe the counts. In normal operation, the count should be 100-200 because the oil level drops when the engine starts and oil from the sump is delivered to other parts of the transmission.

NOTE: *Intermittent connections or lack of battery-direct power and ground connections can cause this and other electronic control codes.*

Main Code	Subcode	Meaning
14	12	Oil level sensor failed low
14	23	Oil level sensor failed high (not used)

A. Active Indicator Clearing Procedure:

- Power down
- Manual
- Self-clearing

CODE 14 XX — OIL LEVEL SENSOR (OLS) (Figure 6-3)

NOTE: Before troubleshooting, read Pages 6-15 and 6-16 of Paragraph 6-5. Also, check the following:

- Fluid level, using dipstick
- Battery voltage
- ECU input voltage
- Other diagnostic codes

B. Troubleshooting:

The following procedure is to find the cause for an OLS problem. The procedure is sequential. Follow the procedure until the cause for the OLS problem is found and repaired. Once the problem is found and repaired, STOP. For example, if the problem is fixed in step 3, there is no need to continue to the other steps.

1. Disconnect the external wiring harness at the transmission feedthrough connector. With the ignition ON, verify there is 5.0 VDC between the OLS power and ground pins (see page D-10) on the external harness connector. This is to verify that power and ground are getting to the OLS. If the 5.0 VDC is not present, check the wiring for the OLS power and ground circuits (wires 124-T9 and 135-T25, respectively). If there are no wiring problems (opens, shorts-to-ground, shorts-to-battery), and if the 5.0 VDC is present, go to Step 2.
2. Observe the OIL LEVEL COUNTS on the DDR while jumpering the OLS power pin to the OLS signal pin. If the count jumps from 0 to 250+, the OLS signal line is good and the ECU function is good. Continue to Step 3. If the count remains at zero, locate and repair problems in the wiring of OLS signal (wire 165-T26). If there are no wiring problems, and the count still remains at zero, the ECU may be bad. Go to Step 5.
3. If all checks prior to this have been normal, the problem is either in the OLS itself, the internal harness wires or the transmission side of the feedthrough harness connection. Inspect the transmission feedthrough harness connector to be sure that the OLS power, ground and signal pins are not loose or out of position. Correct any connector problems found. Reconnect the external harness to the transmission feedthrough harness connector. See if Code 14 12 recurs before continuing to Step 4.
4. Consult the appropriate transmission Service Manual for proper procedure and remove the control module from the transmission. Remove the OLS from the channel plate. Reconnect the external harness to the transmission feedthrough connector, if not done in Step 3. With the ignition ON, observe OIL LEVEL COUNTS on the DDR. With the OLS in normal position, the count should be 8-35. Invert the OLS and the count should be 192-255. If the counts are abnormal, replace the sensor. Check the new sensor in both normal and inverted positions. If the counts respond correctly, the problem should be resolved. Attach the new OLS to the channel plate and reinstall the control module using the appropriate transmission Service Manual for proper procedure.
5. Replace the ECU. If replacing the ECU corrects the problem, reinstall the original (bad) ECU to confirm that the problem is in the ECU. If the original ECU now works, inspect the ECU connectors for any corrosion or damage which may cause an intermittent condition. If the original problem recurs, reinstall the replacement ECU.

DIAGNOSTIC CODES

NOTES

CODE 21 XX — THROTTLE OR PWM FAULT

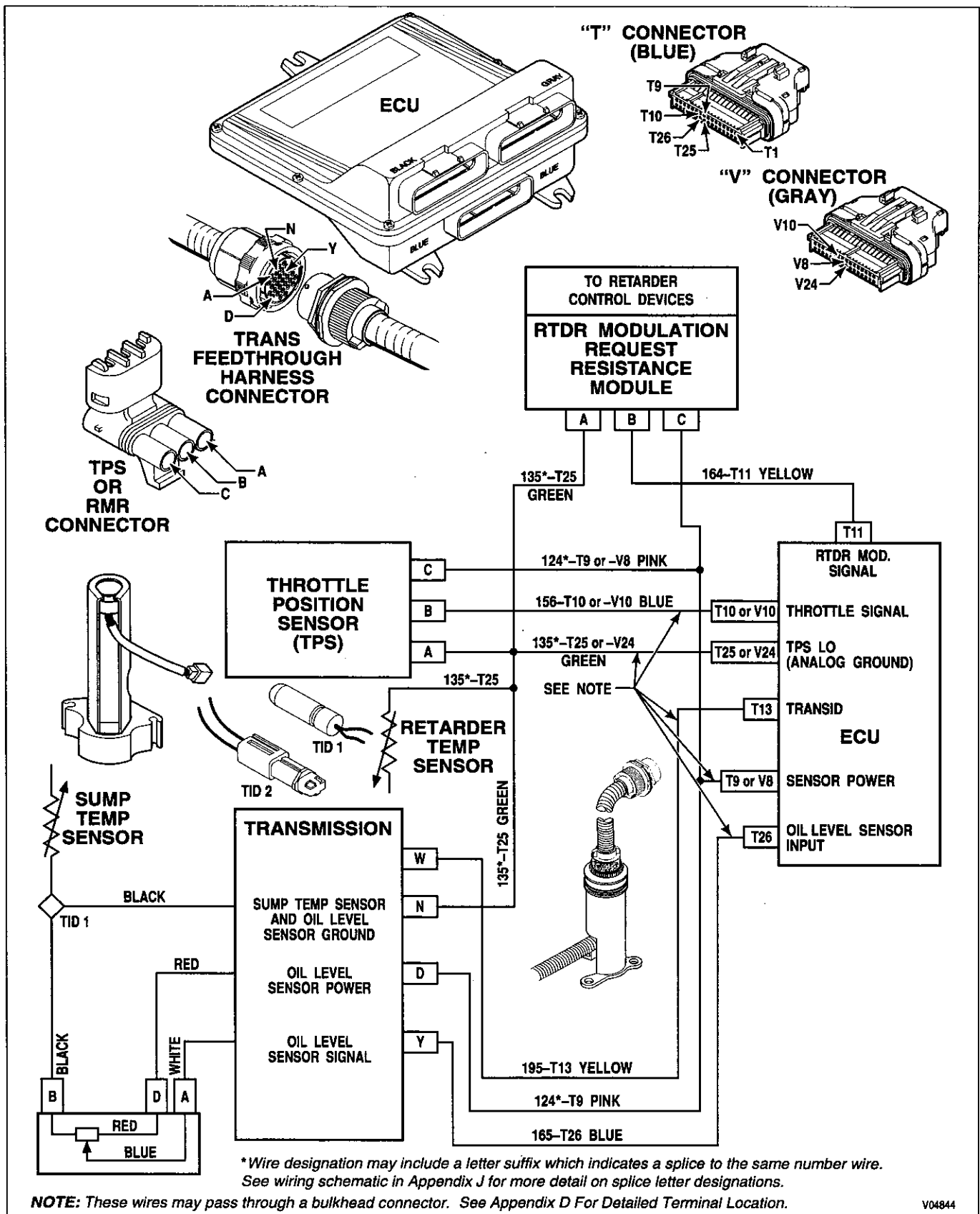

Figure 6-4. Code 21 Schematic Drawing

CODE 21 XX — THROTTLE OR PWM FAULT (Figure 6-4)

The throttle sensor must have been recognized by autodetect or manually selected using the Pro-Link® (see WTEC III Pro-Link® Manual) before these codes can be logged. See Paragraph 1-9 for further information.

Main code 21 indicates the throttle position sensor has been retracted or extended by its linkage into an error zone. This may be due to a fault with the sensor, or a fault in the wiring to the sensor or to the ECU. This code may also indicate a PWM signal problem. A PWM signal is proportional to throttle position and comes from some source other than an analog throttle position sensor. Code 21 12 is set when the ECU receives TPS counts of 14 or less. Code 21 23 is set when the ECU senses TPS counts of 233-255. Whenever a code 21 XX condition is detected, the system uses default throttle values and shifts will not adapt.

NOTE: Code 21 XX in conjunction with code 33 XX or code 14 XX indicates the potential loss of common ground wire 135 between the throttle, temperature sensor, and oil level sensor.

Main Code	Subcode	Meaning
21	12	Throttle position sensor failed low and ECU signals throttle default value
21	23	Throttle position sensor failed high and ECU signals a throttle default value

A. Active Indicator Clearing Procedure:

- Power down
- Manual
- Self-clearing

NOTE: Before troubleshooting, read Pages 6-15 and 6-16 of Paragraph 6-5. Also, check the ECU input voltage.

B. Troubleshooting:

1. Plug in the DDR, select Diagnostic Data, and read throttle counts and percent. If the TPS failed high (code 21 23), the problem may be toward the full throttle end of the TPS travel. If the TPS failed low (code 21 12), the problem may be at the closed throttle end of the TPS travel.

NOTE: Code 21 12 can result when the +5V line (wire 124) which powers the analog sensor is shorted to ground. Wire 124 also powers the OLS, RMR, retarder temperature sensor, sump temperature sensor, and shift selector and is present in all three ECU connectors.

2. If counts are high but the percentage never reaches 100 percent, TPS linkage may have bound up and overstroked the TPS to set a false 100 percent reading. After TPS overstroking ceases, the TPS will not automatically return to 100 percent. After the TPS is correctly installed and adjusted, use the Pro-Link® to reset throttle calibration or cycle the ignition 5 times to reset the 0 percent and 100 percent settings. See the TPS section of this book (Appendix F) for installation and adjustment procedures.
3. If the throttle counts do not change or are erratic, check the throttle sensor wiring for opens, shorts between wires, or shorts-to-ground. Also check for correct TPS voltages using test wiring harness J 41339. If wiring problems are found, isolate and repair the fault (refer to Appendix E for repair information).

CODE 21 XX — THROTTLE OR PWM FAULT (*Figure 6-4*)

4. If the wiring is satisfactory, replace the throttle position sensor and adjust its linkage so the counts are not in the error zones (see Appendix F).
5. If the throttle sensor and its linkage adjustment are correct and the wiring to the sensor is satisfactory, the condition is intermittent. Replace the sensor and properly adjust the new sensor.
6. If the condition recurs, use a spare wire, if available, or provide a new wire (St. Clair P/N 200153 may be used for this purpose) for the throttle sensor circuit. See Appendix E for connector repair information.
7. If the condition persists, replace the ECU. If replacing the ECU corrects the problem, reinstall the original (bad) ECU to confirm that the problem is in the ECU. If the original ECU now works, inspect the ECU connectors for any corrosion or damage which may cause an intermittent condition. If the original problem recurs, reinstall the replacement ECU.

NOTE: *A good throttle position sensor should have resistance of:*

- (1) *9000–15,000 Ohms across terminals A and C.*
- (2) *500 Ohms, moving to 9000–15,000 Ohms as TPS is stroked (measured across terminals A and B).*

DIAGNOSTIC CODES

NOTES

CODE 22 XX — SPEED SENSOR/CIRCUITRY FAULT

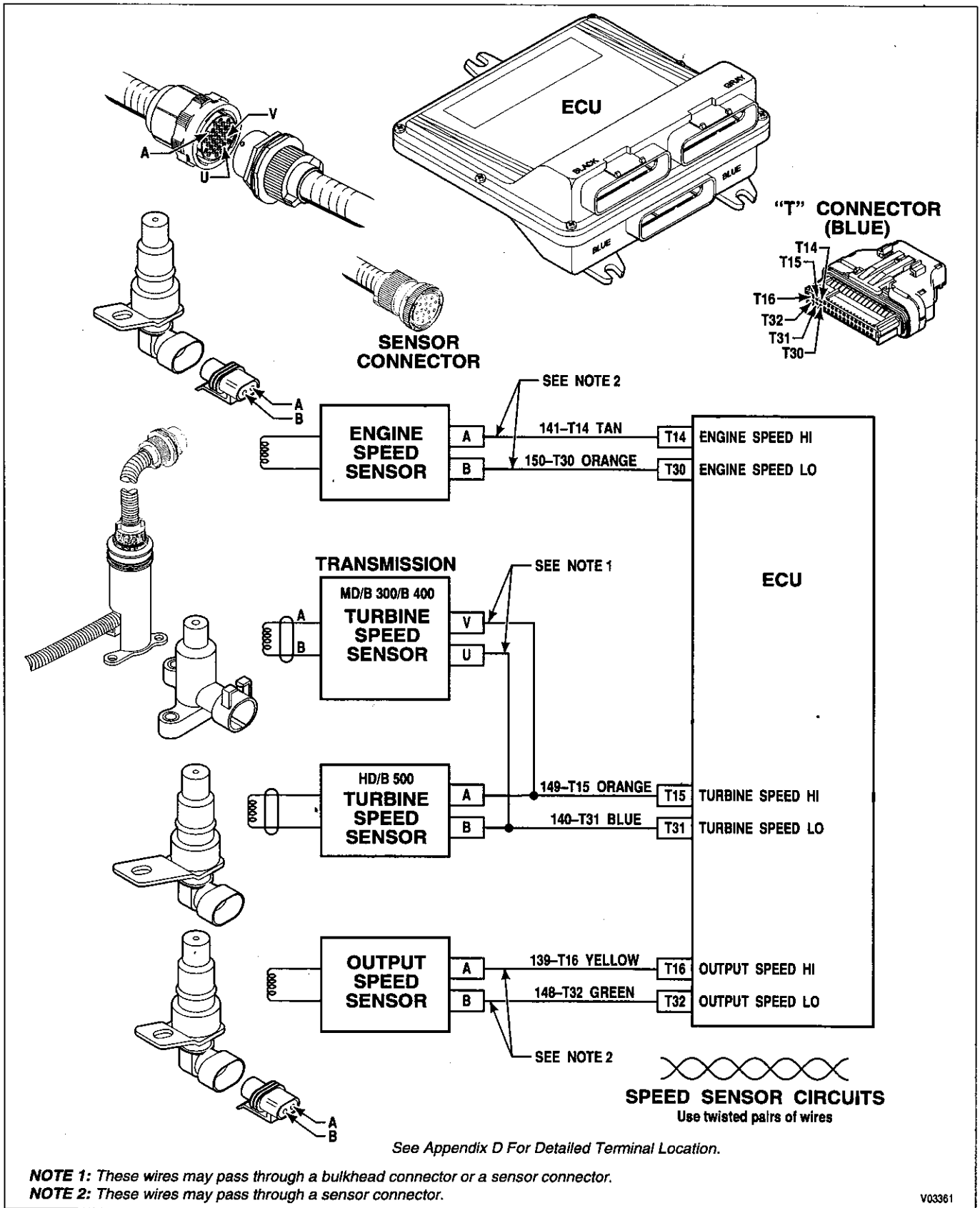

Figure 6-5. Code 22 Schematic Drawing

CODE 22 XX — SPEED SENSOR/CIRCUITRY FAULT (Figure 6-5)

Main code 22 indicates a fault within a speed sensor, the wiring to a speed sensor, incorrect speed sensor gap, or damaged bumps or teeth which create the speed signal. This fault is determined by the reasonableness of a speed sensor signal when compared with the other two speed sensors and the commanded range. A speed sensor will not pass the reasonableness test if there is no signal at all from that sensor when a signal should be present.

NOTE: *If the engine speed sensor code (22 14) is active and a range verification test is failed, the range verification code will not be set but a DO NOT SHIFT response is commanded.*

Main Code	Subcode	Failed Sensor
22	14	Engine Speed
22	15	Turbine Speed
22	16	Output Speed

A. Active Indicator Clearing Procedure:

- Power down
- Manual
- Self-clearing

NOTE: *Before troubleshooting, read Pages 6-15 and 6-16 of Paragraph 6-5. Also, check the ECU input voltage.*

B. Troubleshooting:

1. Check to see if the sensor is loose, missing, or disconnected. If not, disconnect the wiring harness from the sensor and measure the resistance of the sensor (see chart below). Also check the terminals for dirt, corrosion, or damage. If resistance is not correct, replace the sensor.

Resistance	Temp °C	Temp °F
200 Ω	-40	-40
300 Ω	20	68
400 Ω	110	230

2. Remove the transmission harness connector from the ECU. Check the sensor circuit (in the external harness) for open wires, shorts between wires, or shorts-to-ground. Isolate and repair any faults (refer to Appendix E for repair information).
3. If no opens or shorts are found, the condition must be intermittent. Replace the sensor indicated by the trouble code. Before replacing a speed sensor, check the sensor for physical damage or contamination. Refer to the appropriate transmission Service Manual for proper replacement procedure.
4. If the condition recurs, install new wiring (twisted-pair) for the sensor circuit between the ECU and the transmission. Use St. Clair P/N 200153 Service Harness Twisted Pair for this purpose.
5. If the condition again recurs, connect the diagnostic tool and select the speed signal indicated by the trouble code. Drive the vehicle and watch the speed reading on the diagnostic tool. If the signal is erratic, sensor gap, vehicle vibration, an external AC signal source, or intermittent connector contact may be inducing the erratic signal. Inspect the sensor and its surroundings for irregularities that would affect sensor gap. Isolate and correct any abnormal vehicle vibrations (particularly driveline and abnormal engine torsionals, see Sales Tech Data Book, Part II, Section C). Recheck the sensor wiring for intermittent conditions (see Appendix A).

CODE 22 XX — SPEED SENSOR/CIRCUITRY FAULT (*Figure 6-5*)

6. If the condition persists, replace the ECU. If replacing the ECU corrects the problem, reinstall the original (bad) ECU to confirm that the problem is in the ECU. If the original ECU now works, inspect the ECU connectors for any corrosion or damage which may cause an intermittent condition. If the original problem recurs, reinstall the replacement ECU.

DIAGNOSTIC CODES

NOTES

CODE 23 XX — SHIFT SELECTOR

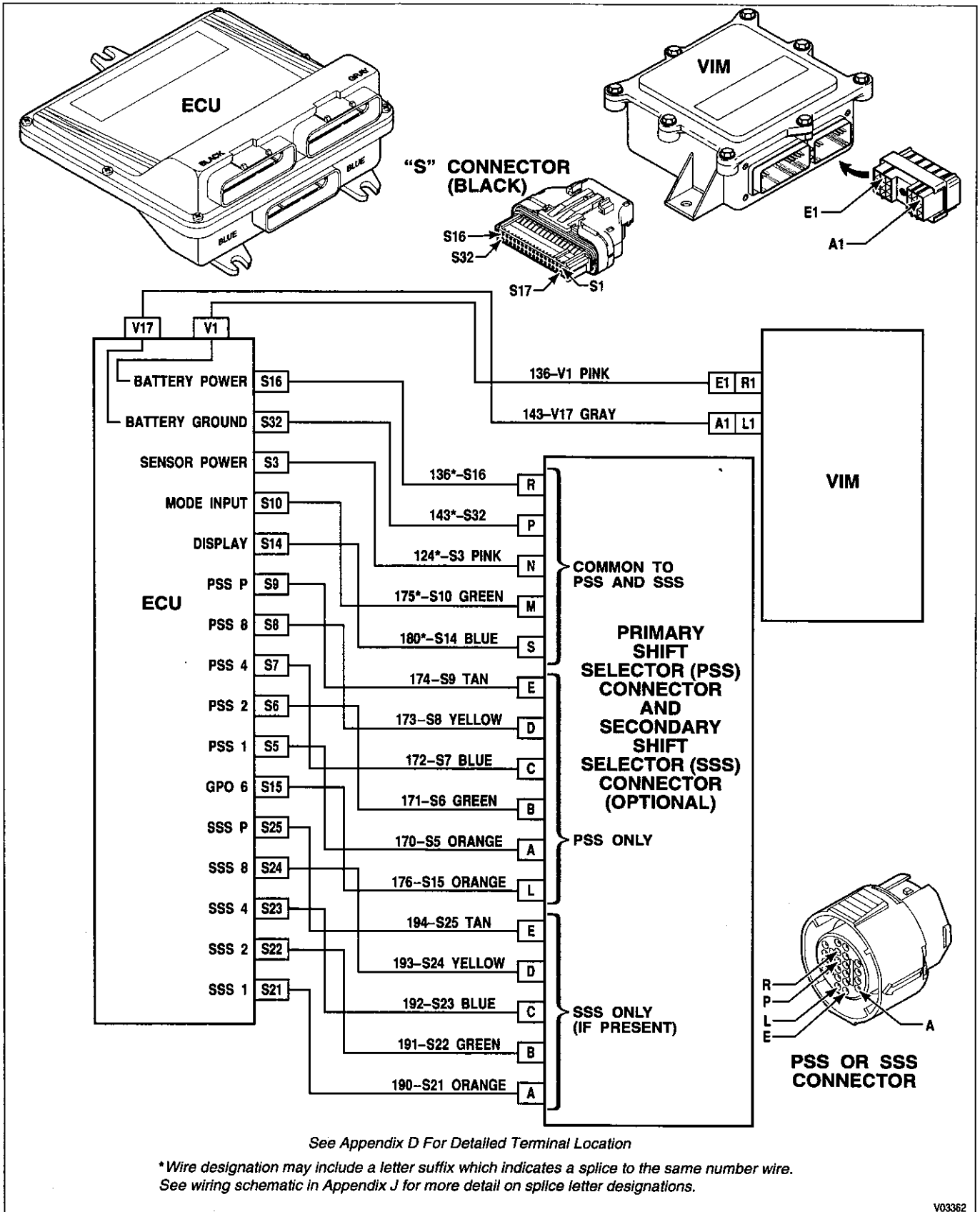

Figure 6-6. Code 23 Schematic Drawing

CODE 23 XX — SHIFT SELECTOR (Figure 6-6)

Main code 23 indicates a fault with a shift selector or the wiring between a shift selector and the ECU.

Main Code	Subcode	Meaning
23	12	Primary shift selector fault — a “cateye” type display may occur
23	13	Primary shift selector mode function fault. Mode change not permitted
23	14	Secondary shift selector fault — a “cateye” type display may occur
23	15	Secondary shift selector mode function fault. Mode change not permitted
23	16	Shift selector display line fault

A. Active Indicator Clearing Procedure:

- Power down
- Manual
- Self-clearing

NOTE: Before troubleshooting, read Pages 6-15 and 6-16 of Paragraph 6-5.

B. Troubleshooting:

1. Clear the active indicator for code 23 XX. If code recurs, continue to Step (2).
2. Check for a poor connection at the shift selector.

NOTE: Code 23 12 can result when the +5V line (wire 124) which powers the shift selector is shorted to ground. Wire 124 also powers the TPS, OLS, RMR, retarder temperature sensor, and sump oil temperature sensor and is present in all three ECU connectors.

3. Disconnect the selector “S” harness connector from the ECU and from the shift selector and check for opens, shorts, and shorts-to-ground between the shift selector and ECU (refer to Section 4). Repair as needed (refer to Appendix E).
4. If no problem is found with the shift selector connection or wiring, replace the shift selector.
5. If the condition persists, replace the ECU. If replacing the ECU corrects the problem, reinstall the original (bad) ECU to confirm that the problem is in the ECU. If the original ECU now works, inspect the ECU connectors for any corrosion or damage which may cause an intermittent condition. If the original problem recurs, reinstall the replacement ECU.

CODE 24 XX — SUMP FLUID TEMPERATURE

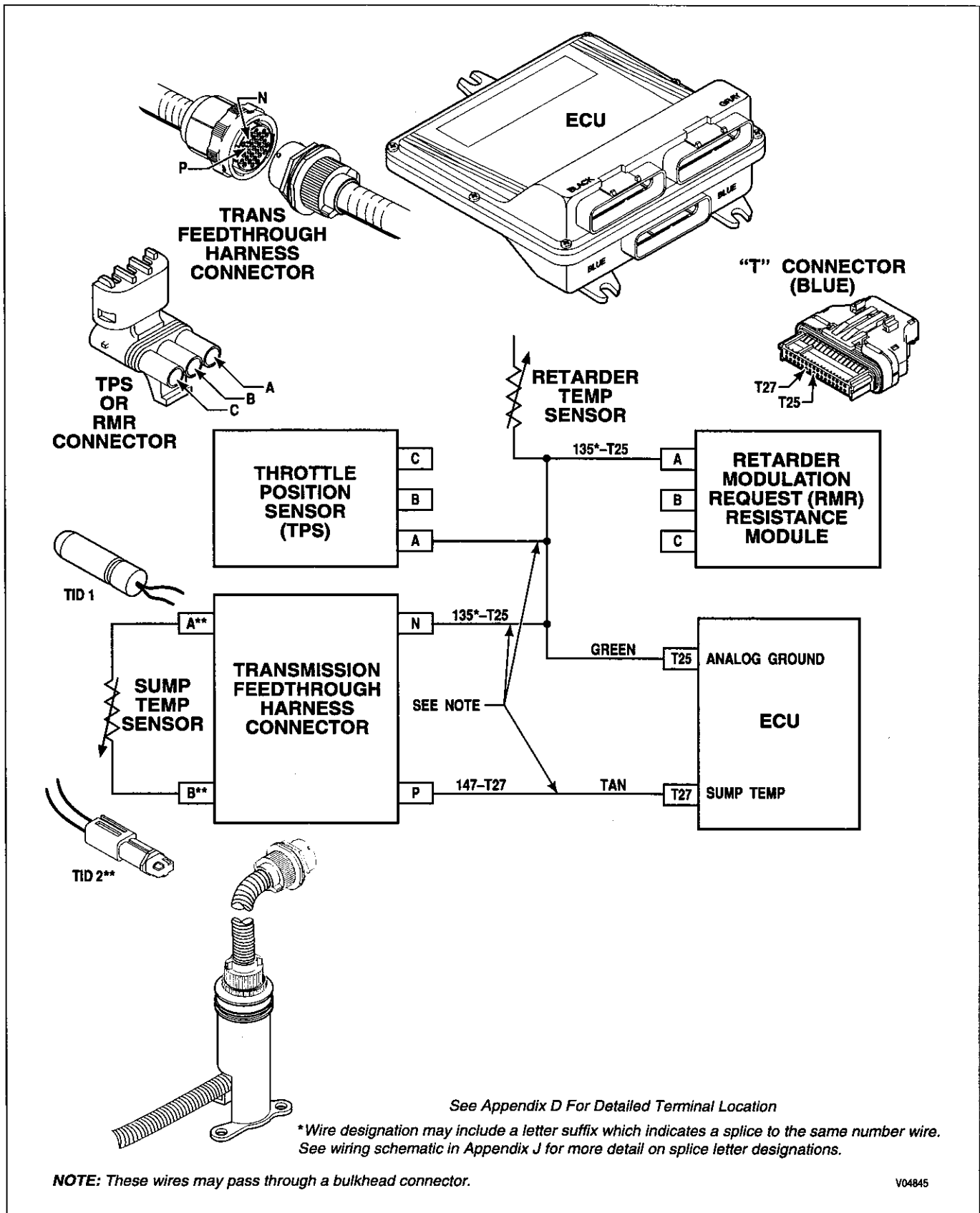

Figure 6-7. Code 24 Schematic Drawing

CODE 24 XX — SUMP FLUID TEMPERATURE *(Figure 6-7)*

Main code 24 indicates the ECU has detected either a high or low fluid temperature in the transmission sump (via the sump temperature sensor in the internal harness). All shifts are inhibited when code 24 12 is set (only Neutral range operation is allowed). No upshifts are allowed above a calibration range when code 24 23 is set. All inhibits are cleared when the temperature conditions are normal. A related code is 33 12 which indicates a temperature reading outside the usable range of the sensor and indicates a probable sensor failure.

NOTE: *When an ECU with a version 8 calibration (CIN=0A...) is used with a TransID 2 transmission, 24 XX codes are set because the ECU does not have the proper calibrations for the TID 2 thermistors. The ECU calibration must be updated to version 8A or later (CIN=0B).*

TransID (TID) information related to thermistor changes is in Paragraph 1-10 and detailed troubleshooting information for TID 2 thermistors is shown in Appendix Q.

Main Code	Subcode	Meaning
24	12	Sump fluid temperature cold
24	23	Sump fluid temperature hot

A. Active Indicator Clearing Procedure:

- Power down
- Manual
- Self-clearing

NOTE: *Before troubleshooting, read Pages 6-15 and 6-16 of Paragraph 6-5. Also, check the ECU input voltage.*

B. Troubleshooting:

Code 24 12:

1. If code 24 12 is set and the outside temperature is between -32°C (-25°F) and -7°C (+20°F), the ECU will allow reverse, neutral, and second-range start operation. Only hold override upshifts are allowed. (See Table 6-4 on next page). The sump must be warmed to an acceptable temperature to avoid logging codes and transmission diagnostic response.

NOTE: *Code 24 12 can result when the +5V line (wire 124) which powers the sump temperature sensor is shorted to ground. Wire 124 also powers the TPS, OLS, RMR, retarder temperature sensor, and shift selectors and is present in all three ECU connectors.*

2. If ambient temperature does not match the sump temperature reading (check using diagnostic tool), compare resistance versus sump fluid temperature (refer to Figure 6-8 for TID 1 thermistors and Appendix Q for TID 2 thermistors). Then check the sensor wiring for opens, shorts, or shorts-to-ground.
3. If the sensor wiring is satisfactory, drain the fluid, remove the control module, and replace the temperature sensor (refer to appropriate transmission Service Manual).
4. If the condition persists, replace the ECU. If replacing the ECU corrects the problem, reinstall the original (bad) ECU to confirm that the problem is in the ECU. If the original ECU now works, inspect the ECU connectors for any corrosion or damage that may cause an intermittent condition. If the original problem recurs, reinstall the replacement ECU.

CODE 24 XX — SUMP FLUID TEMPERATURE (Figure 6-7)

Table 6-4. Transmission Operation as a Function of Temperature

Condition	Version 8 Software	
	°C	°F
Temperature sensor failed high (refer to code 33 23)	177	351
Hot fluid (code 24 23) adaptive turned off; maximum range limited (not limited in "emergency" calibration)	128	262
Output function "on" for sump over temp above this temperature	121	250
Output function "off" for sump over temp below this temperature	116	240
Cool/cold fluid; adaptive turned off	34	93
Turbine reasonableness and speed tie-up tests turned off	0	32
Medium cold fluid R, N, D allowed, 2nd range start (hold override upshifts only)	-7	19
All C3 Pressure Switch tests turned off	-32	-25
Temperature sensor failed low (refer to code 33 12)	-45	-49

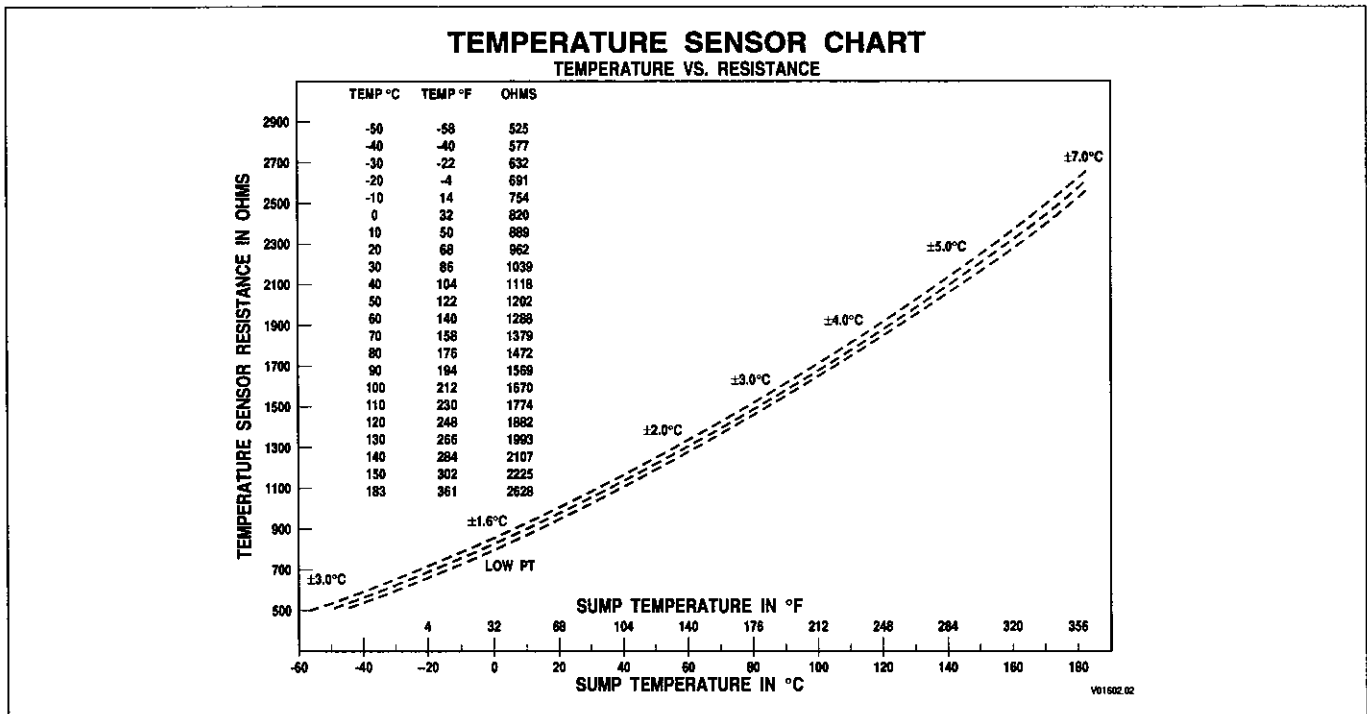

Figure 6-8. TransID 1 Temperature Sensor Chart

Code 24 23:

1. Install temperature gauges for transmission temperature and engine water temperature. Drive the vehicle. Verify that the code can be reproduced and verify the reading shown on the diagnostic tool. Observe the gauges and check for hot fluid when the code is produced.
2. If the fluid is not hot when the code is produced, remove the transmission "T" harness connector at the ECU and the transmission. Check the fluid temperature sensor wiring for opens, shorts, and shorts-to-ground. Compare the resistance readings of the sensor and the actual temperature as shown on the gauge with Figure 6-8 for TID 1 thermistors and Appendix Q for TID 2

CODE 24 XX — SUMP FLUID TEMPERATURE (Figure 6-7)

thermistors. If wiring problems or a great difference between temperature and resistance compared with the chart are found, drain the fluid, remove the control module, and replace the temperature sensor (refer to the Service Manual for the transmission being checked). If wiring problems are found, repair or replace as necessary.

3. If the fluid is hot when the code is produced, observe the gauges to see if the engine became hot before the transmission. If the engine cooling system is overheating and heating the transmission, the problem is with the engine or its cooling system.
4. If the transmission became hot before the engine, allow the vehicle to idle for 3-5 minutes and check the transmission fluid level. Correct the fluid level if necessary.
5. Attach pressure gauges to the cooling system (from a "to cooler" connection to a point after the cooling circuit filter) and check for pressure drop problems. If pressure drop is excessive (refer to Table 6-5), check for a plugged cooler filter, collapsed lines, obstructions, etc.
6. If the fluid level is correct and the cooling circuits satisfactory, drain the fluid, remove the control module, and inspect for damaged valve body gaskets. Replace any damaged gaskets (refer to the appropriate transmission Service Manual).
7. If no problems are found in the control module area, remove the transmission and disassemble, inspecting for causes of overheating (stuck stator, plugged orifices, dragging clutches, etc.). (See the Service Manual for the transmission being checked.)

**Table 6-5. External Hydraulic Circuit Characteristics
Basic, PTO, 93°C (200°F) Sump Temperature**

HD/B 500

**CONVERTER OPERATION
MAXIMUM COOLER FLOW
AT MINIMUM PRESSURE DROP**

Input rpm	Flow		Pressure Drop	
	L/s	gpm	kPa	psi
600	0.22	3.4	0	0
900	0.38	6.1	0	0
1200	0.55	8.7	0	0
1500	0.80	12.7	0	0
1800	1.03	16.4	0	0
2100	1.13	18.0	0	0
2300	1.20	19.0	0	0

**CONVERTER OPERATION
COOLER FLOW AT MAXIMUM
ALLOWABLE PRESSURE DROP**

Input rpm	Flow		Pressure Drop	
	L/s	gpm	kPa	psi
600	0.20	3.2	31	4.5
900	0.37	5.8	63	9.1
1200	0.55	8.7	108	15.7
1500	0.77	12.2	167	24.2
1800	0.92	14.5	213	30.9
2100	0.97	15.3	238	34.5
2300	1.00	15.9	250	36.3

CODE 24 XX — SUMP FLUID TEMPERATURE (Figure 6-7)

Table 6-6. External Hydraulic Circuit Characteristics
Basic, PTO, 93°C (200°F) Sump Temperature

MD/B 300/B 400

**CONVERTER OPERATION
MAXIMUM COOLER FLOW
AT MINIMUM PRESSURE DROP**

Input rpm	Flow		Pressure Drop	
	L/s	gpm	kPa	psi
600	0.10	1.6	0	0
800	0.23	3.7	0	0
1200	0.47	7.4	0	0
1400	0.61	9.7	0	0
1600	0.74	11.7	0	0
2000	0.94	14.9	0	0
2400	1.19	18.9	0	0
3200	1.28	20.3	0	0

**LOCKUP OPERATION
MAXIMUM COOLER FLOW
AT MINIMUM PRESSURE DROP**

Input rpm	Flow		Pressure Drop	
	L/s	gpm	kPa	psi
600	0.10	1.6	0	0
800	0.23	3.7	0	0
1200	0.50	7.9	0	0
1400	0.63	10.0	0	0
1600	0.77	12.2	0	0
2000	0.95	15.1	0	0
2400	1.12	17.8	0	0
2800	1.22	19.3	0	0
3200	1.28	20.3	0	0

**CONVERTER OPERATION
MAXIMUM ALLOWABLE
PRESSURE DROP**

Input rpm	Flow		Pressure Drop	
	L/s	gpm	kPa	psi
600	0.10	1.6	10	1.5
800	0.22	3.5	40	5.8
1200	0.45	7.1	159	23.1
1400	0.57	9.0	252	36.5
1600	0.67	10.6	338	49.0
2000	0.80	12.7	481	69.8
2400	0.85	13.5	549	79.6
3200	0.85	13.5	549	79.6

**LOCKUP OPERATION
MAXIMUM ALLOWABLE
PRESSURE DROP**

Input rpm	Flow		Pressure Drop	
	L/s	gpm	kPa	psi
600	0.10	1.6	5	0.7
800	0.23	3.7	46	6.7
1200	0.48	7.6	148	21.5
1400	0.62	9.8	247	35.8
1600	0.73	11.6	346	50.2
2000	0.90	14.3	561	81.4
2400	1.07	17.0	737	106.9
2800	1.10	17.4	770	111.7
3200	1.10	17.4	791	114.7

DIAGNOSTIC CODES

NOTES

CODE 25 XX — OUTPUT SPEED SENSOR, DETECTED AT ZERO SPEED, X RANGE

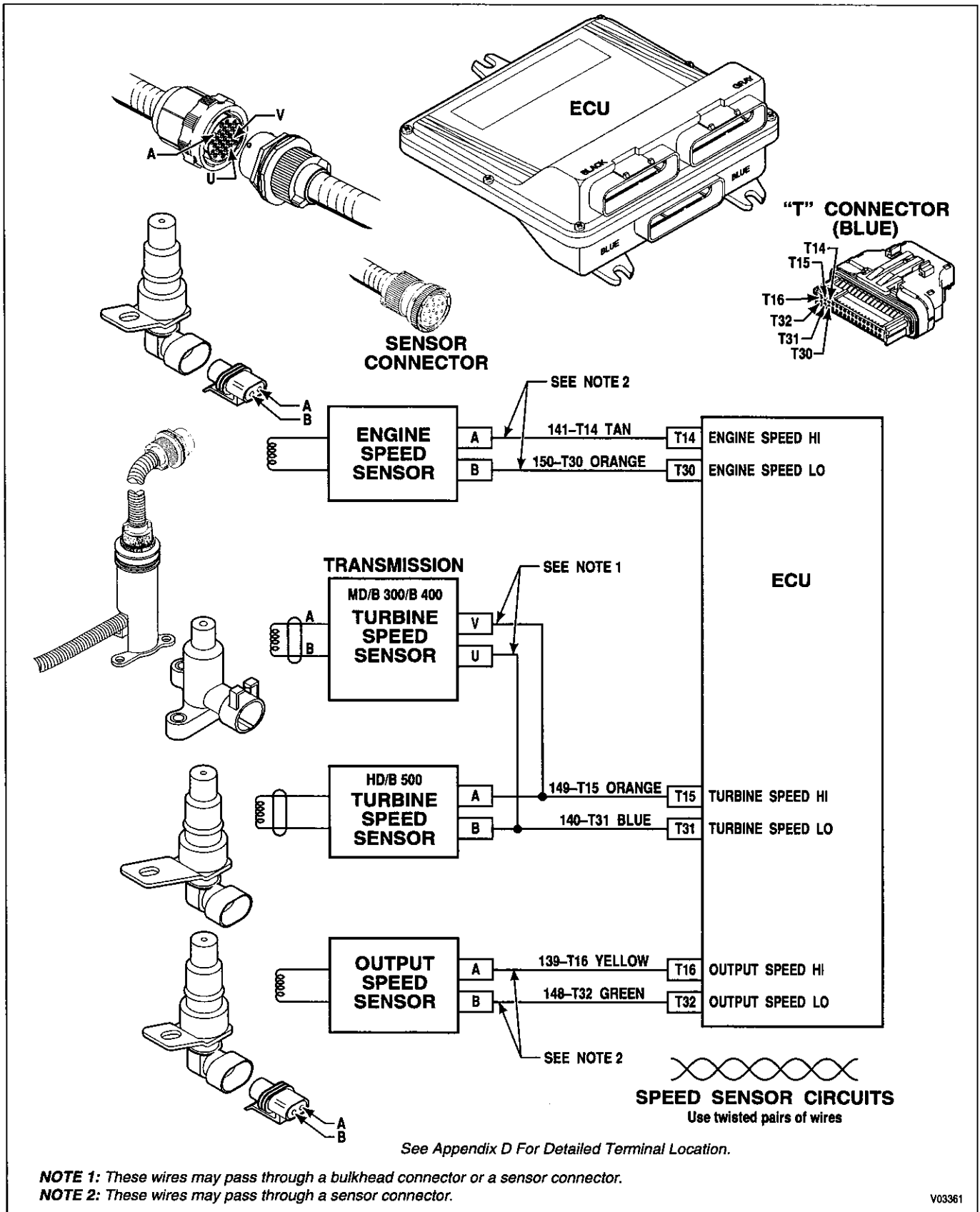

Figure 6-9. Code 25 Schematic Drawing

CODE 25 XX — OUTPUT SPEED SENSOR, DETECTED AT ZERO SPEED, X RANGE (Figure 6-9)

Main code 25 occurs if the output speed sensor reports a zero speed reading while both engine and turbine speeds are approximately equal, turbine speed is above a calibration value, and neutral is not selected or commanded. Main code 25 indicates either the output speed sensor has failed or the required oncoming clutch or clutches did not come on. Code 25 11 can be generated by a false turbine speed reading. This may be due to crosstalk between solenoid and turbine speed sensor circuits caused by direct wire-to-wire short or by water in the electrical connectors. See Section 4 for corrective action.

NOTE: *If code 25 XX is in memory at ECU initialization (ignition on), all display segments are illuminated.*

Main Code	Subcode	Meaning	Applied Clutches
25	00	Output speed sensor, detected at zero speed, Low range	C3, C6
25	11	Output speed sensor, detected at zero speed, 1st range	C1, C5
25	22	Output speed sensor, detected at zero speed, 2nd range	C1, C4
25	33	Output speed sensor, detected at zero speed, 3rd range	C1, C3
25	44	Output speed sensor, detected at zero speed, 4th range	C1, C2
25	55	Output speed sensor, detected at zero speed, 5th range	C2, C3
25	66	Output speed sensor, detected at zero speed, 6th range	C2, C4
25	77	Output speed sensor, detected at zero speed, Reverse	C3, C5

A. Active Indicator Clearing Procedure:

- Power down
- Manual
- Self-clearing

NOTE: *Before troubleshooting, read Pages 6-15 and 6-16 of Paragraph 6-5. Also, check battery and ECU input voltages.*

NOTE: *Intermittent connections or lack of battery-direct power and ground connections can cause this and other codes.*

B. Troubleshooting:

1. Check the transmission fluid level and ensure correct fluid level.
2. Check for the presence of code 22 16. If code 22 16 is in the code list, go to code 22 XX section and follow troubleshooting steps for code 22 16.
3. Connect the Pro-Link® 9000 with ignition on, engine off; check for indication of turbine speed. If turbine speed is indicated, refer to Paragraph 4-2 for corrective action.
4. If the output speed sensor and wiring are satisfactory, install pressure gauges into the appropriate clutch pressure taps (see appropriate transmission Service Manual or Appendix B in this manual) and make the shift again. See if either of the clutches has low or no pressure. Lack of pressure in C1 in first range may be due to a G solenoid stuck closed.
5. If a clutch is leaking pressure, drain the fluid, remove the control module and check for damaged valve body gaskets and stuck or sticky valves. If no problems are found, replace the solenoids for the clutches used in the range indicated by the code (refer to Figure 6-1). Refer to the appropriate transmission Service Manual for replacement procedure.

**CODE 25 XX — OUTPUT SPEED SENSOR, DETECTED AT ZERO SPEED,
X RANGE** (Figure 6-9)

6. If, after detecting leaking pressure and replacing solenoids, the problem persists, check for worn clutch or piston seals. Remove the transmission and repair or replace as necessary (refer to the proper transmission Service Manual).
7. This code requires accurate output and turbine speed readings. If there were no transmission problems detected, use the diagnostic tool and watch the speed readings for noise (erratic signals) from low speed to high speed in the range indicated by the code.
8. If a noisy sensor is found, check the sensor resistance (refer to the sensor resistance chart below) and check its wiring for opens, shorts, and shorts-to-ground (see code 22 XX). Also closely check the terminals in the connectors for corrosion, contamination, or damage. Ensure the wiring to the sensors is a properly twisted wire pair. Remove sensor and check for damage at the tone wheel end. Check for looseness of the tone wheel. Refer to the appropriate Service Manual if repair of a loose tone wheel is necessary. Replace the sensor if it is damaged or if its resistance (refer to Service Manual for proper procedure) is incorrect and isolate and repair any noted wiring problems. (Use St. Clair P/N 200153 Service Harness Twisted Pair for this procedure.)

Resistance	Temp. °C	Temp. °F
200 Ω	-40	-40
300 Ω	20	68
400 Ω	110	230

9. If no apparent cause for the code can be located, replace the turbine and output speed sensors. Refer to the appropriate transmission Service Manual for proper procedure.
10. If the condition persists, replace the ECU. If replacing the ECU corrects the problem, reinstall the original (bad) ECU to confirm that the problem is in the ECU. If the original ECU now works, inspect the ECU connectors for any corrosion or damage which may cause an intermittent condition. If the original problem recurs, reinstall the replacement ECU.

CODE 26 XX — THROTTLE SOURCE/ENGINE COOLANT SOURCE NOT DETECTED

Main code 26 occurs when the ECU has not detected either a throttle source or an engine coolant source. This is a new code related to the autodetect feature which is described in Paragraph 1-9.

Main Code	Subcode	Meaning
26	00	Throttle source not detected
26	11	Engine coolant source not detected

Code 26 00 means that the ECU has not detected the presence of engine throttle data or analog circuitry. For details about autodetect or using Pro-Link[®] to select a throttle source, see Paragraph 1-9 and the WTEC III Pro-Link[®] Manual.

Code 26 11 means that the ECU has not detected the presence of engine coolant temperature data or analog circuitry. For details about autodetect or using Pro-Link[®] to select an engine coolant temperature source, see Paragraph 1-9 and the WTEC III Pro-Link[®] Manual.

A. Active Indicator Clearing Procedure

- Power down
- Manual

B. Troubleshooting

1. When code 26 00 is logged and an analog TPS is known to be installed, refer to code 21 XX for troubleshooting steps. If a J1587 or J1939 throttle signal is used, refer to code 66 00 for troubleshooting steps.
2. When code 26 11 is logged and if an analog engine coolant temperature sensor is being used, refer to code 62 XX for troubleshooting steps. If a J1587 or J1939 engine coolant temperature signal is being used, refer to code 66 00 for troubleshooting steps.

CODE 32 XX — C3 PRESSURE SWITCH

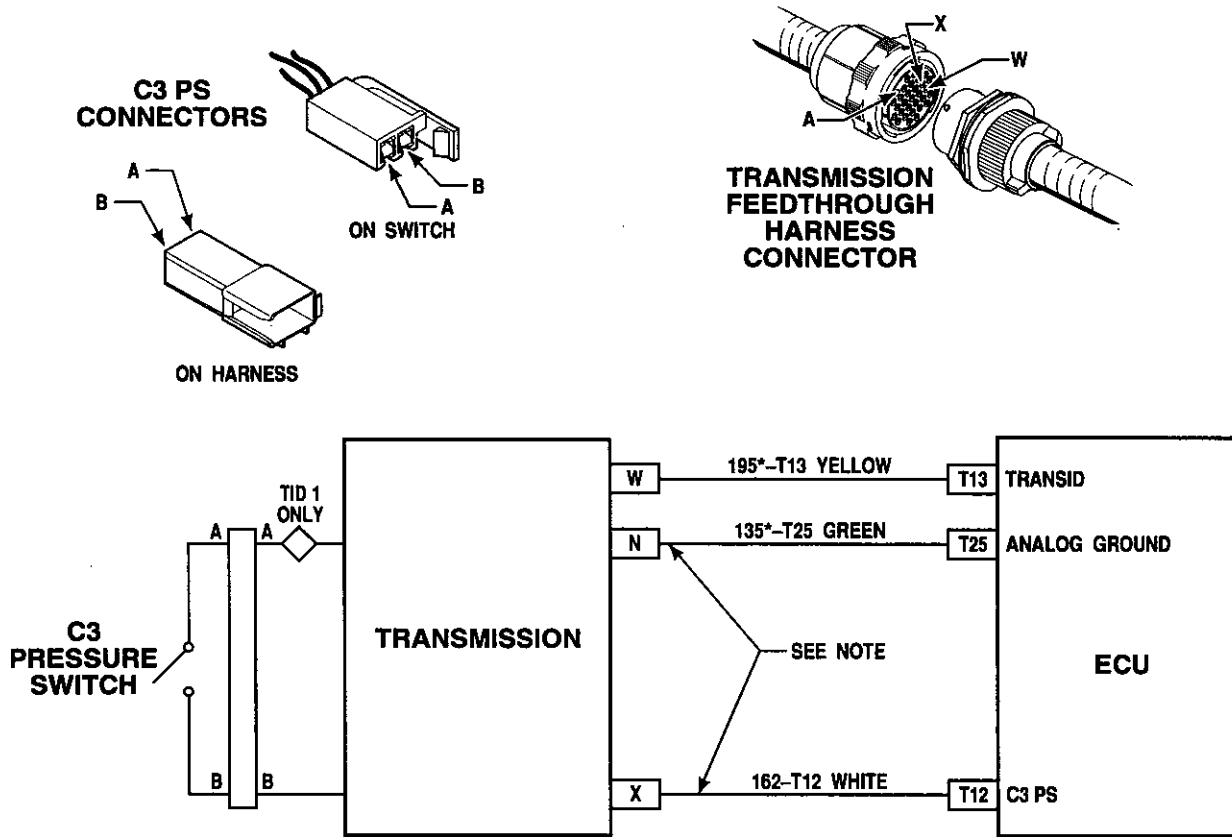

C3 PS CONNECTORS

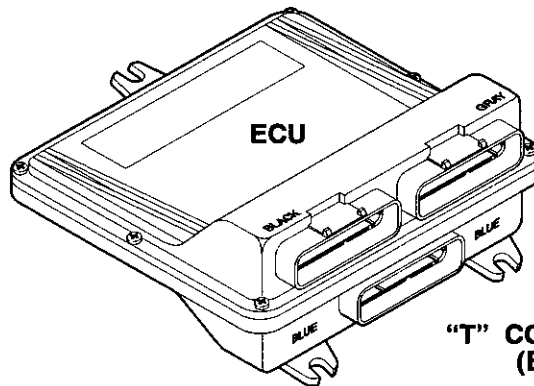
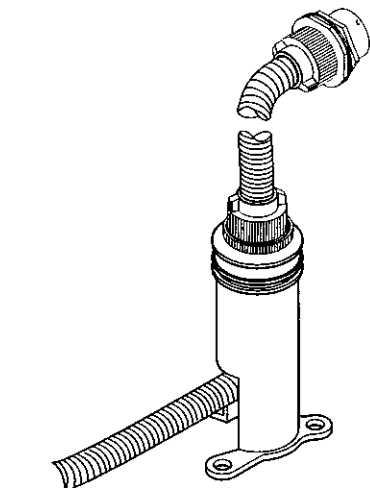
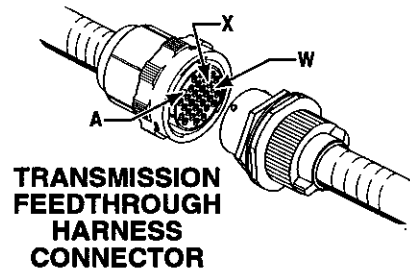
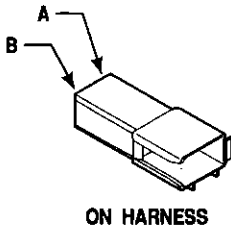

"T" CONNECTOR (BLUE)

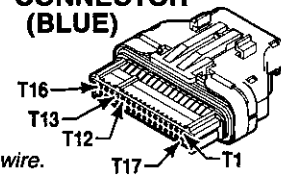

See Appendix D For Detailed Terminal Location

*Wire designation may include a letter suffix which indicates a splice to the same number wire. See wiring schematic in Appendix J for more detail on splice letter designations.

NOTE: These wires may pass through a bulkhead connector.

V04848

Figure 6-10. Code 32 Schematic Drawing

CODE 32 XX — C3 PRESSURE SWITCH (Figure 6-10)

Main code 32 indicates the transmission gear ratio is correct, but the C3 pressure switch is open when it should be closed.

NOTE: *When an ECU with a version 8 or 8A calibration is used with a pre-TransID transmission, 32 XX codes are set because the ECU sees wire 195 is open. To correct this condition, convert to a TID 1 internal harness or install Adapter P/N 200100 available from St. Clair Technologies. See addresses on Page 1-7.*

Further TransID (TID) information is in Paragraph 1-10.

Main Code	Subcode	Meaning
32	00	C3 switch open in low range (MD 3070)
32	33	C3 switch open in third range
32	55	C3 switch open in fifth range
32	77	C3 switch open in reverse range

A. Active Indicator Clearing Procedure:

- Power down
- Manual
- Self-clearing

NOTE: *Before troubleshooting, read Pages 6-15 and 6-16 of Paragraph 6-5. Also, check battery and ECU input voltages.*

B. Troubleshooting:

1. Disconnect the transmission "T" harness connector at the ECU and the transmission. Check the C3 switch circuit for opens, shorts to other wires, shorts-to-ground, or short-to-battery. If wiring problems are found, isolate and repair. The C3 pressure switch closes at 206.8 ± 48 kPa (30 ± 7 psi); resistance should be 2 Ohms maximum when the switch is closed and 20,000 to infinity when the switch is open. Infinity is often indicated as OL (over limit) on a DVOM.
2. If problems are not found in the external harness, drain the fluid, remove the control module, and check the internal harness for opens, shorts between wires, or shorts-to-ground (refer to the proper transmission Service Manual). If wiring problems are found, isolate and repair (see Appendix E, Paragraph 1-9).
3. If no wiring problems are found, replace the C3 pressure switch (refer to transmission Service Manual).
4. If the problem recurs, use a spare wire, if available, or provide a new wire (St. Clair P/N 200153 may be used for this purpose) for the C3 pressure switch circuit.
5. If the problem recurs again, replace the internal harness.
6. If the condition persists, replace the ECU. If replacing the ECU corrects the problem, reinstall the original (bad) ECU to confirm that the problem is in the ECU. If the original ECU now works, inspect the ECU connectors for any corrosion or damage which may cause an intermittent condition. If the original problem recurs, reinstall the replacement ECU.

CODE 33 XX — SUMP OIL TEMPERATURE SENSOR

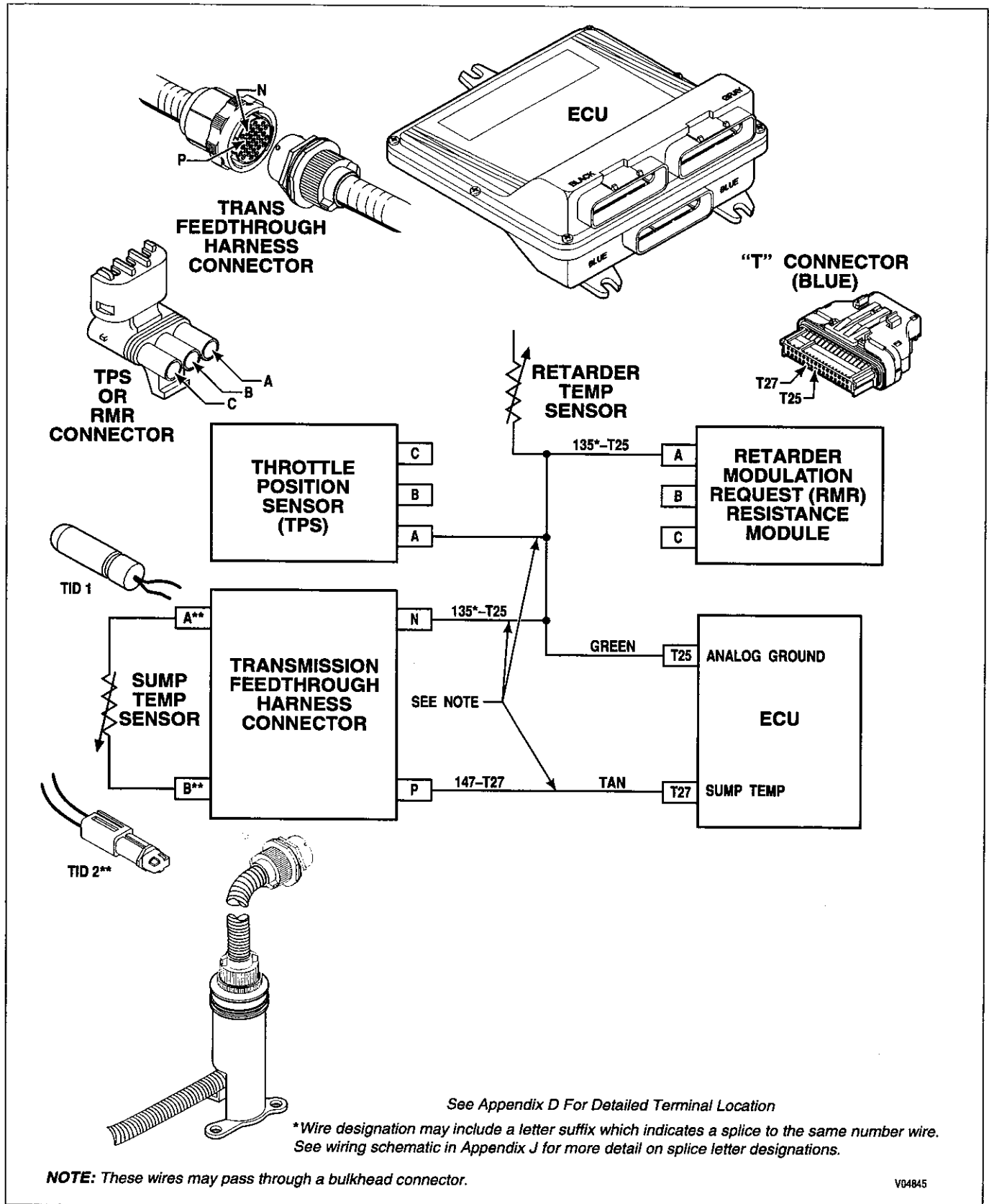

Figure 6-11. Code 33 Schematic Drawing

CODE 33 XX — SUMP OIL TEMPERATURE SENSOR (Figure 6-11)

NOTE: When an ECU with a version 8 calibration (CIN=0A...) is used with a Trans ID 2 transmission, 33 XX codes are set because the ECU does not have the proper calibrations for the TID 2 thermistors. The ECU calibration must be updated to version 8A or later (CIN=0B...).

TransID (TID) information related to thermistor changes is in Paragraph 1-10 and detailed troubleshooting information for TID 2 thermistors is shown in Appendix Q.

Main code 33 indicates the sump temperature sensor is providing a signal outside the usable range of the ECU. This code indicates the sensor failed showing abnormally high or low temperature readings. Main code 33 can be caused by a component or circuit failure or by extremely high or low temperatures. There are no operational inhibits related to main code 33. The ECU assumes a hardware failure and that transmission temperatures are normal (93°C; 200°F). Temperatures above or below normal cause poor shift quality.

NOTE: Code 33 23 in conjunction with code 21 23 indicates the loss of common ground (wire 135) between the throttle and temperature sensors.

Main Code	Subcode	Meaning
33	12	Sump oil temperature sensor failed low
33	23	Sump oil temperature sensor failed high

A. Active Indicator Clearing Procedure:

- Power down
- Manual
- Self-clearing

NOTE: Before troubleshooting, read Pages 6-15 and 6-16 of Paragraph 6-5. Also, check the transmission fluid level.

B. Troubleshooting:

NOTE: Code 33 12 can be caused when the +5V power line (wire 124) is shorted to ground or open. Wire 124 also provides power for the OLS, TPS, RMR, retarder temperature sensor, and shift selectors and is present in all three ECU connectors.

1. If possible, check the sump temperature with a DDR. Use the fastest sample rate available on the DDR. This is necessary to catch momentary changes due to an intermittent open or short to ground. If a DDR is not available, use the shift selector display to determine if the code is active (refer to Paragraph 6-2). Disconnect the transmission "T" harness at the ECU and check resistance of the sensor and compare with Figure 6-12.

CODE 33 XX — SUMP OIL TEMPERATURE SENSOR (Figure 6-11)

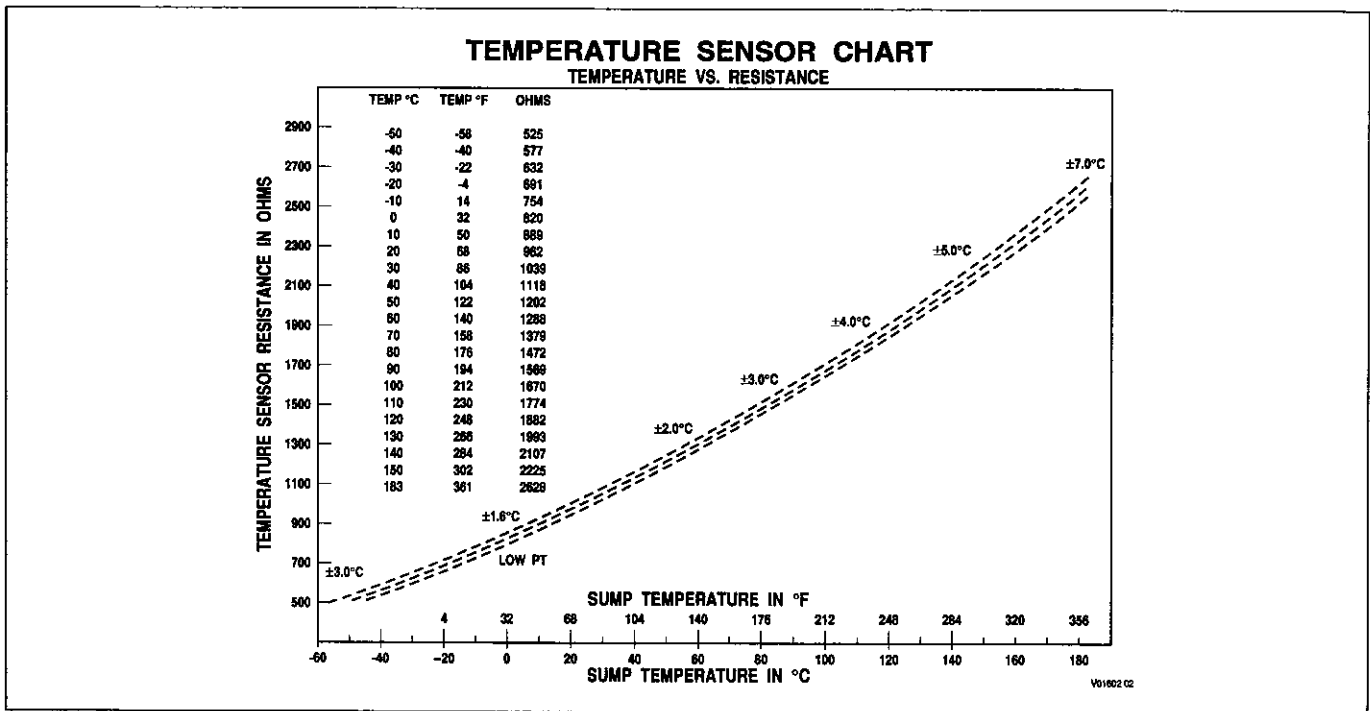

Figure 6-12. Temperature Sensor Chart

2. If Step (1) reveals that the extreme temperature indication is no longer present, the temperature limit could have been reached due to operational or ambient temperature extremes. Also, you may be experiencing an intermittent problem and the code will not be active. Proceed cautiously, it is unlikely there is a sensor hardware fault.
3. Disconnect the external harness at the transmission. Check the connectors and terminals for dirt, corrosion, or damage. Clean or replace as necessary.
4. Check the sensor wires in the external harness for opens (code 33 23), shorts between wires, or shorts-to-ground (code 33 12 — refer to Section 4). If wiring problems are found, isolate and repair as described in Appendix E.
5. If no harness problems are found, check the feedthrough harness for damage. If the feedthrough harness connector is satisfactory, drain the fluid and remove the control module. Check for chafing of the sensor wires, especially near the separator plate. Eliminate the chafe point. If no chafe point is found, replace the sensor (refer to the Transmission Service Manual and Appendix E, Paragraph 1-12 in this manual).
6. If the problem recurs, use a spare wire, if available, or provide a new wire (St. Clair P/N 200153 may be used for this purpose) for the temperature sensor circuit.
7. If the condition persists, replace the ECU. If replacing the ECU corrects the problem, reinstall the original (bad) ECU to confirm that the problem is in the ECU. If the original ECU now works, inspect the ECU connectors for any corrosion or damage which may cause an intermittent condition. If the original problem recurs, reinstall the replacement ECU.

CODE 34 XX — CALIBRATION COMPATIBILITY OR CHECKSUM FAULT

Main code 34 indicates there is a problem with the calibration.

Main Code	Subcode	Meaning
34	12	Factory calibration compatibility number wrong
34	13	Factory calibration checksum
34	14	Power off block checksum
34	15	Diagnostic queue block checksum
34	16	Real-time block checksum
34	17	Customer modifiable constants checksum

A. Active Indicator Clearing Procedure:

- Power down

NOTE: *Copying the current calibration from the ECU and reloading it will not correct the fault. The calibration must be downloaded directly from PCCS.*

B. Troubleshooting:

1. If the code set is 34 14 and it occurs in conjunction with code 35 00, proceed to find the cause for code 35 00 and correct it.
2. After the cause for code 35 00 has been corrected, drive the vehicle to see if code 34 14 recurs. If code 34 14 recurs, proceed to Step (3).
3. Reprogram the correct calibration. Contact your nearest Allison distributor/dealer location qualified to do recalibration. Be certain the calibration and the software level are compatible.
4. If the code recurs after reprogramming, replace the ECU.
5. If the code set is 34 17, reprogram the GPI/GPO package after re-calibration of the ECU.

CODE 35 XX — POWER INTERRUPTION

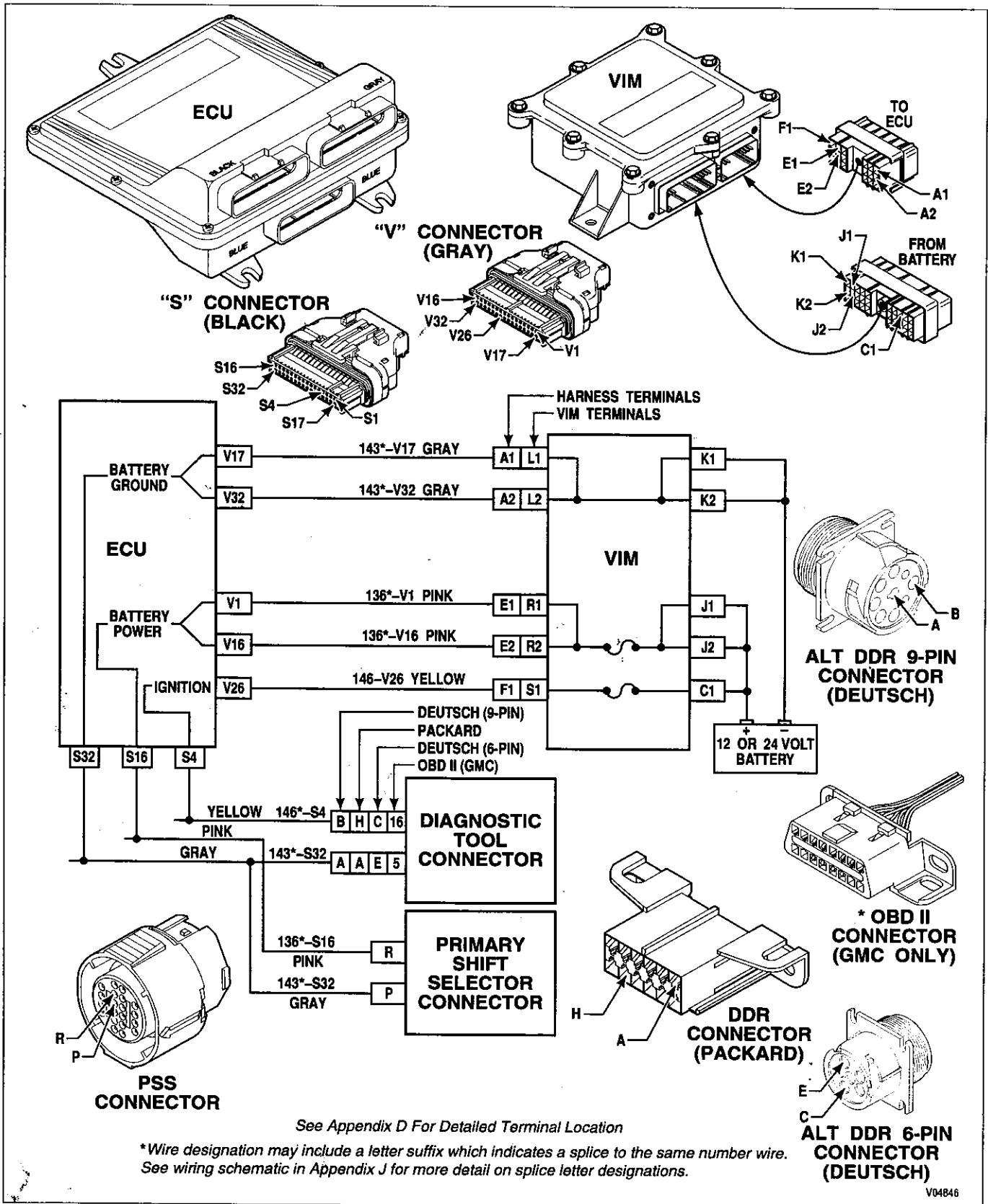

Figure 6-13. Code 35 Schematic Drawing

CODE 35 XX — POWER INTERRUPTION (Figure 6-13)

Main code 35 indicates the ECU has detected a complete power loss before the ignition was turned off or before ECU shutdown is completed. When this happens, the ECU is not able to save the current operating parameters in memory before turning itself off.

Main Code	Subcode	Meaning
35	00	Power interruption. (Not an active code; only appears after power is restored.) During power interruption, DNS light is not illuminated and the transmission will not shift.
35	16	Real-time write interruption. (Power interruption at the same time the ECU is recording a critical code to the real-time section.)

A. Active Indicator Clearing Procedure:

- Power down
- Manual — except code 35 16

NOTE: Before troubleshooting, read Pages 6-15 and 6-16 of Paragraph 6-5. Also, check battery and ECU input voltages.

B. Troubleshooting:

1. If the vehicle has a master switch controlling battery power to the ECU and an ignition switch, turning the master switch off before turning the ignition switch off can cause this code. Turning the master switch off before ECU shutdown is completed will also cause this code. No troubleshooting is necessary.
2. If improper switch sequencing is not the cause, check ECU power and ground for opens, shorts, and shorts-to-ground. Not using battery-direct power and battery ground connections can cause this code. A defective charging system, or open battery fuse or fusible link can also cause this code. The battery fuse or fusible link may be at the battery or in the VIM. Dirty, corroded, or painted power and ground connections can also cause this code.
3. If all system power and ground connections are satisfactory and the problem persists, replace the ECU. If replacing the ECU corrects the problem, reinstall the original (bad) ECU to confirm that the problem is in the ECU. If the original ECU now works, inspect the ECU connectors for any corrosion or damage which may cause an intermittent condition. If the original problem reoccurs, reinstall the replacement ECU.

DIAGNOSTIC CODES

NOTES

CODE 36 XX — HARDWARE AND SOFTWARE NOT COMPATIBLE

Main code 36 indicates the system has detected a mismatch between the ECU hardware and the ECU software or that there is a TransID (TID) problem.

Main Code	Subcode	Meaning
36	00	Mismatch between ECU hardware and software
36	01	TransID not compatible with hardware/software
36	02	TransID did not complete

A. Active Indicator Clearing Procedure:

- Power down

B. Troubleshooting:

1. Correction for code 36 00 requires the installation of software that is compatible with the ECU hardware involved. (If a different calibration is required, update the ECU hardware to be compatible.)
2. Correction for code 36 01 is to update the ECU calibration. Installation of the latest calibration makes the ECU compatible with the latest TransId configuration. For further information about TransID see Paragraph 1-10.
3. Correction for code 36 02 is to troubleshoot TransID wire 195 for short-to-battery. Codes 42 XX or 69 XX may be associated with this code.

CODE 42 XX — SHORT-TO-BATTERY IN SOLENOID CIRCUIT

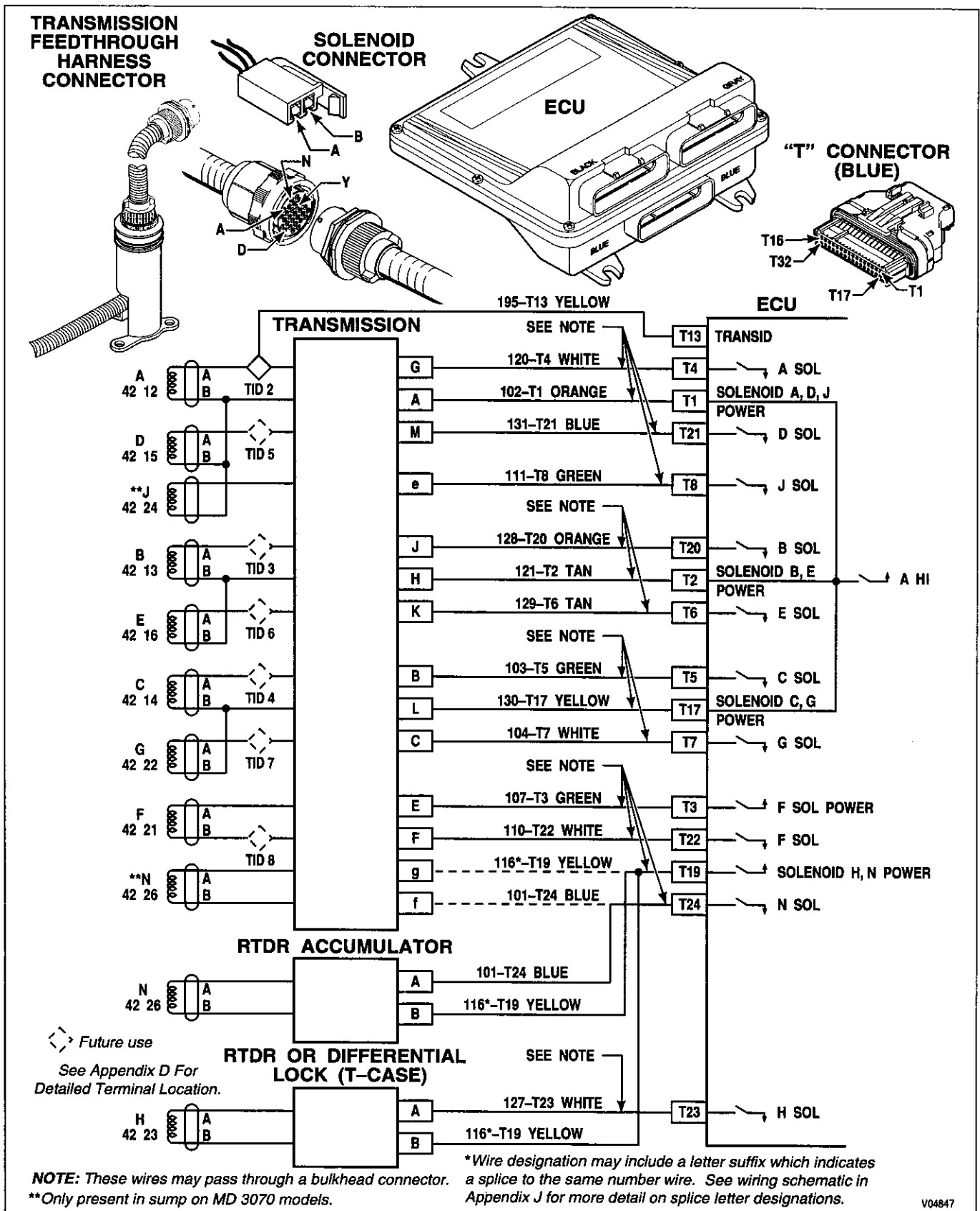

Figure 6-14. Code 42 Schematic Drawing

CODE 42 XX — SHORT-TO-BATTERY IN SOLENOID CIRCUIT (Figure 6-14)

Main code 42 indicates the ECU has detected a short-to-battery condition in a solenoid wiring circuit. The **DO NOT SHIFT** response is activated when some subcodes are detected, all solenoids are turned off and the **CHECK TRANS** light is illuminated. All solenoids have a driver on the low (ground) side which can turn off the solenoid. All solenoids also have a driver on the high (power) side of the solenoid. Even though the high side driver can be turned off, a short-to-battery means the solenoid is continuously powered at an unregulated 12V or 24V instead of a regulated (pulse width modulated) voltage. The low side driver will not tolerate direct battery current and will open, causing the solenoid to be deenergized.

NOTE: For subcodes 12, 13, 14, 15, 16, 22 — neutral start is inoperable; all display segments are on if the code is logged during ECU initialization (ignition on). Subcodes 21, 23, 24, and 26 will not trigger the **CHECK TRANS** light.

Main Code	Subcode	Meaning
42	12	Short-to-battery A Solenoid Circuit
42	13	Short-to-battery B Solenoid Circuit
42	14	Short-to-battery C Solenoid Circuit
42	15	Short-to-battery D Solenoid Circuit
42	16	Short-to-battery E Solenoid Circuit
42	21	Short-to-battery F Solenoid Circuit
42	22	Short-to-battery G Solenoid Circuit
42	23	Short-to-battery H Solenoid Circuit
42	24	Short-to-battery J Solenoid Circuit
42	26	Short-to-battery N Solenoid Circuit

A. Active Indicator Clearing Procedure:

- Power down
- Manual

NOTE: Intermittent connections or lack of battery-direct power and ground connections may cause this and other codes.

NOTE: Before troubleshooting, read Pages 6-15 and 6-16 of Paragraph 6-5. Also, check battery and ECU input voltages.

NOTE: Energizing the solenoids and listening for ball/plunger movement is sometimes useful in troubleshooting.

NOTE: "N" solenoid on the retarder accumulator has a 12 Ohm coil and is not correlated to sump temperature.

PROBING THE CONNECTOR

When testing the control system from the feedthrough connector with the internal harness connected, the resistance of each solenoid can be measured by using a VOM. Refer to Figure 6-15 for solenoid resistance versus temperature.

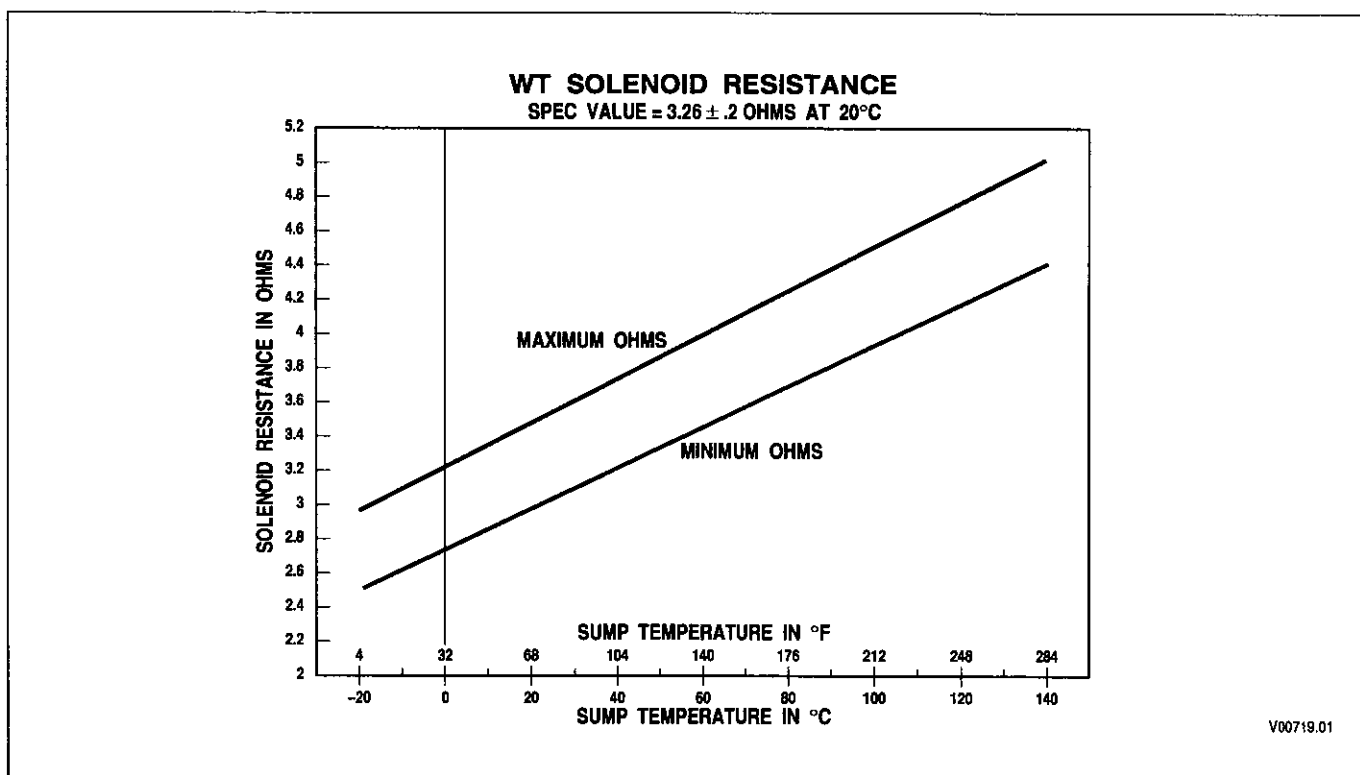
CODE 42 XX — SHORT-TO-BATTERY IN SOLENOID CIRCUIT (Figure 6-14)**Figure 6-15. Solenoid Resistance vs. Temperature****B. Troubleshooting:**

1. Make sure the transmission connector is tightly connected. If the connector is properly connected, disconnect the wiring harness at the transmission. Check the connector for corroded or damaged terminals. Clean or replace as necessary.
2. Test each solenoid circuit at the transmission connector for shorts between the solenoid circuit being diagnosed and all other terminals in the connector. This test may be simplified by using the J 38850 test tool. Refer to the system schematic and/or chart to identify wires in the internal harness which are connected. If a short is found, isolate and repair the short. The short will probably be in the internal wiring harness.
3. If multiple code 42s occur (42 12, 42 13, 42 14, 42 15, 42 16, 42 22, and 42 24), and wiring and solenoids check okay, the A-Hi driver is probably failed open.
4. Replace the ECU. If replacing the ECU corrects the problem, reinstall the original (bad) ECU to confirm that the problem is in the ECU. If the problem recurs, reinstall the new ECU to complete the repair.
5. If code 42 21 occurs repeatedly and the F solenoid and wiring checks okay, the F-Hi or F-Lo driver may be failed open. Follow Step (4) above.
6. If codes 42 23 and 42 26 occur repeatedly and solenoids and wiring check okay, the H and N-Hi driver may be failed open. Follow Step (4) above.
7. If the short is not found at the transmission connector, disconnect the transmission "T" harness connector at the ECU and check the wires of the solenoid circuit for shorts between the solenoid wires. If the short is found in one of the wires, isolate and repair it. Use a spare wire, if available, or provide a new wire (St. Clair P/N 200153 may be used for this purpose).

CODE 42 XX — SHORT-TO-BATTERY IN SOLENOID CIRCUIT (*Figure 6-14*)

8. If the short is not found in either the transmission or the harness, the condition must be intermittent.
9. Drain the fluid, remove the control module (see the transmission Service Manual) and closely inspect the internal harness for damage. Repair or replace as necessary.
10. If the condition recurs, use a spare wire, if available, or provide a new wire (St. Clair P/N 200153 may be used for this purpose) for the solenoid circuit indicated by the trouble code. (Refer to Appendix E for connector assembly/disassembly information.)
11. If the condition persists, replace the ECU. If replacing the ECU corrects the problem, reinstall the original (bad) ECU to confirm that the problem is in the ECU. If the original ECU now works, inspect the ECU connectors for any corrosion or damage which may cause an intermittent condition. If the original problem recurs, reinstall the replacement ECU.

CODE 44 XX — SHORT-TO-GROUND IN SOLENOID CIRCUIT

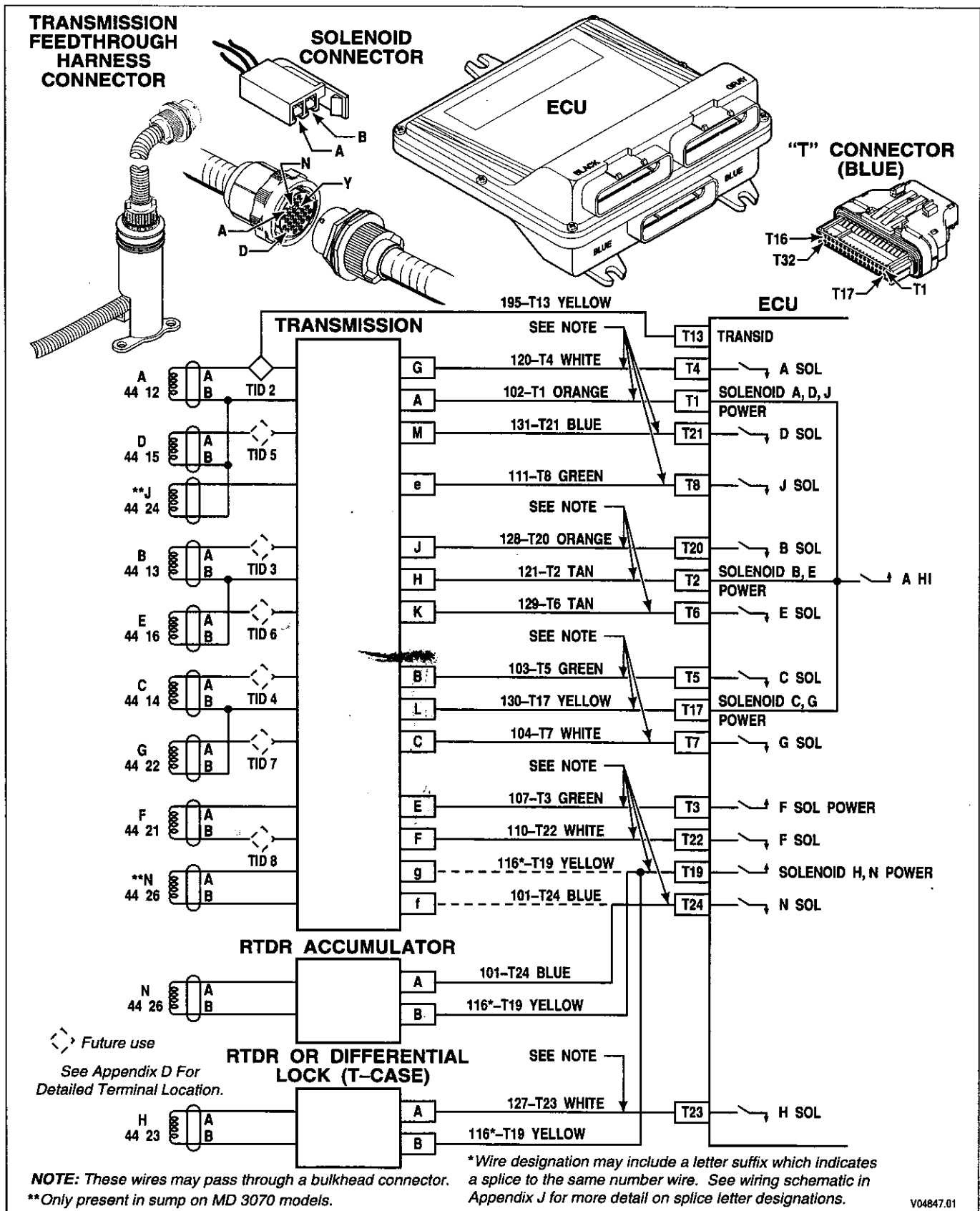

Figure 6-16. Code 44 Schematic Drawing

CODE 44 XX — SHORT-TO-GROUND IN SOLENOID CIRCUIT (Figure 6-16)

Main code 44 indicates the ECU has detected a short-to-ground in a solenoid or its wiring. The **DO NOT SHIFT** response is activated when some subcodes are detected, all solenoids are turned off, and the **CHECK TRANS** light is illuminated.

NOTE: For subcodes 12, 13, 14, 15, 16, 22 — neutral start is inoperable. Subcodes 21, 23, 24, and 26 do not trigger the **CHECK TRANS** light.

Main Code	Subcode	Meaning
44	12	Short-to-ground A Solenoid Circuit
44	13	Short-to-ground B Solenoid Circuit
44	14	Short-to-ground C Solenoid Circuit
44	15	Short-to-ground D Solenoid Circuit
44	16	Short-to-ground E Solenoid Circuit
44	21	Short-to-ground F Solenoid Circuit
44	22	Short-to-ground G Solenoid Circuit
44	23	Short-to-ground H Solenoid Circuit
44	24	Short-to-ground J Solenoid Circuit
44	26	Short-to-ground N Solenoid Circuit

A. Active Indicator Clearing Procedure:

- Power down
- Manual

NOTE: Intermittent connections or lack of battery-direct power and ground connections may cause this and other codes.

NOTE: Before troubleshooting, read Pages 6-15 and 6-16 of Paragraph 6-5. Also, check battery and ECU input voltages.

PROBING THE CONNECTOR

When testing the control system from the feedthrough connector with the internal harness connected, the resistance of each solenoid can be checked using a VOM. Refer to Figure 6-17 for resistance values versus temperature.

CODE 44 XX — SHORT-TO-GROUND IN SOLENOID CIRCUIT (Figure 6-16)

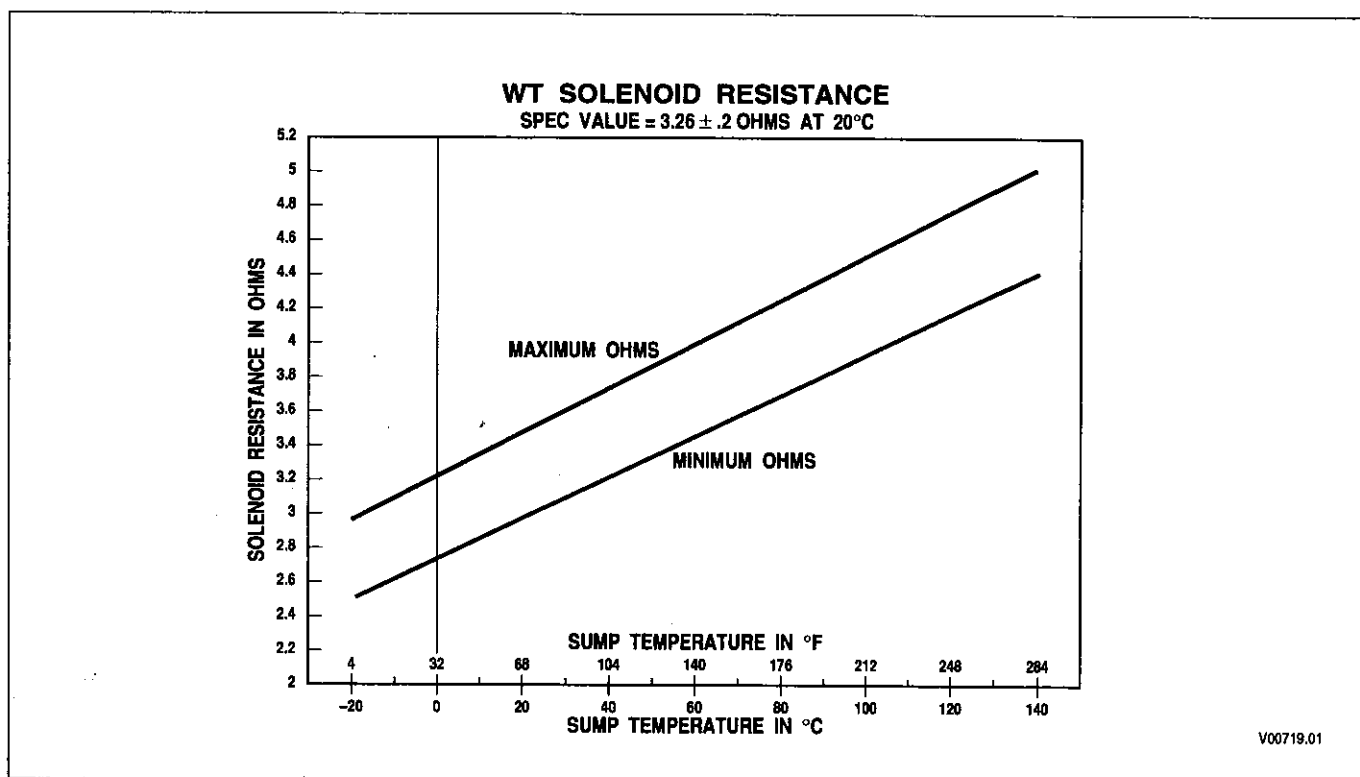

Figure 6-17. Solenoid Resistance vs. Temperature

B. Troubleshooting:

1. Check the transmission connector and make sure it is tightly connected. If the connector is properly connected, disconnect the harness at the transmission and inspect the terminals in the transmission harness and feedthrough harness connectors. Clean or replace as necessary (Appendix D).
2. If the connector is connected, clean, and not damaged, check the solenoid circuit in the transmission for shorts to other wires. (Tool J 38850 may be useful in making this test.) Refer to the system schematic and/or chart to identify wires in the internal harness which are connected. If the short circuit is found, drain the fluid, remove the control module (refer to the transmission Service Manual), and isolate the short. The short is probably in the feedthrough harness, or the solenoid itself (refer to Figure 6-1 for solenoid locations).
3. If the short is not found in the transmission, disconnect the transmission harness connector at the ECU and inspect the terminals for damage or contamination. Clean or replace as necessary. If the terminals are satisfactory, check the wires of the solenoid circuit in the transmission harness for shorts-to-ground or shorts between wires. If a short is found in one of the wires, isolate and repair it or use a spare wire, if available, or provide a new wire (St. Clair P/N 200153 may be used for this purpose) in the external harness. Refer to Appendix E for connector/terminal repair information.
4. If the short is not found in either the transmission or the harness, the condition must be intermittent.
5. Drain the fluid, remove the control module, and closely inspect the solenoid and internal harness for damage. Repair or replace as necessary (refer to the transmission Service Manual).

CODE 44 XX — SHORT-TO-GROUND IN SOLENOID CIRCUIT (*Figure 6-16*)

6. If the condition recurs, use a spare wire, if available, or provide a new wire (St. Clair P/N 200153 may be used for this purpose) for the solenoid circuit indicated by the diagnostic code. See Appendix E for connector assembly/disassembly information.
7. If the condition persists, replace the ECU. If replacing the ECU corrects the problem, reinstall the original (bad) ECU to confirm that the problem is in the ECU. If the original ECU now works, inspect the ECU connectors for any corrosion or damage which may cause an intermittent condition. If the original problem recurs, reinstall the replacement ECU.

CODE 45 XX — OPEN CONDITION IN SOLENOID CIRCUIT

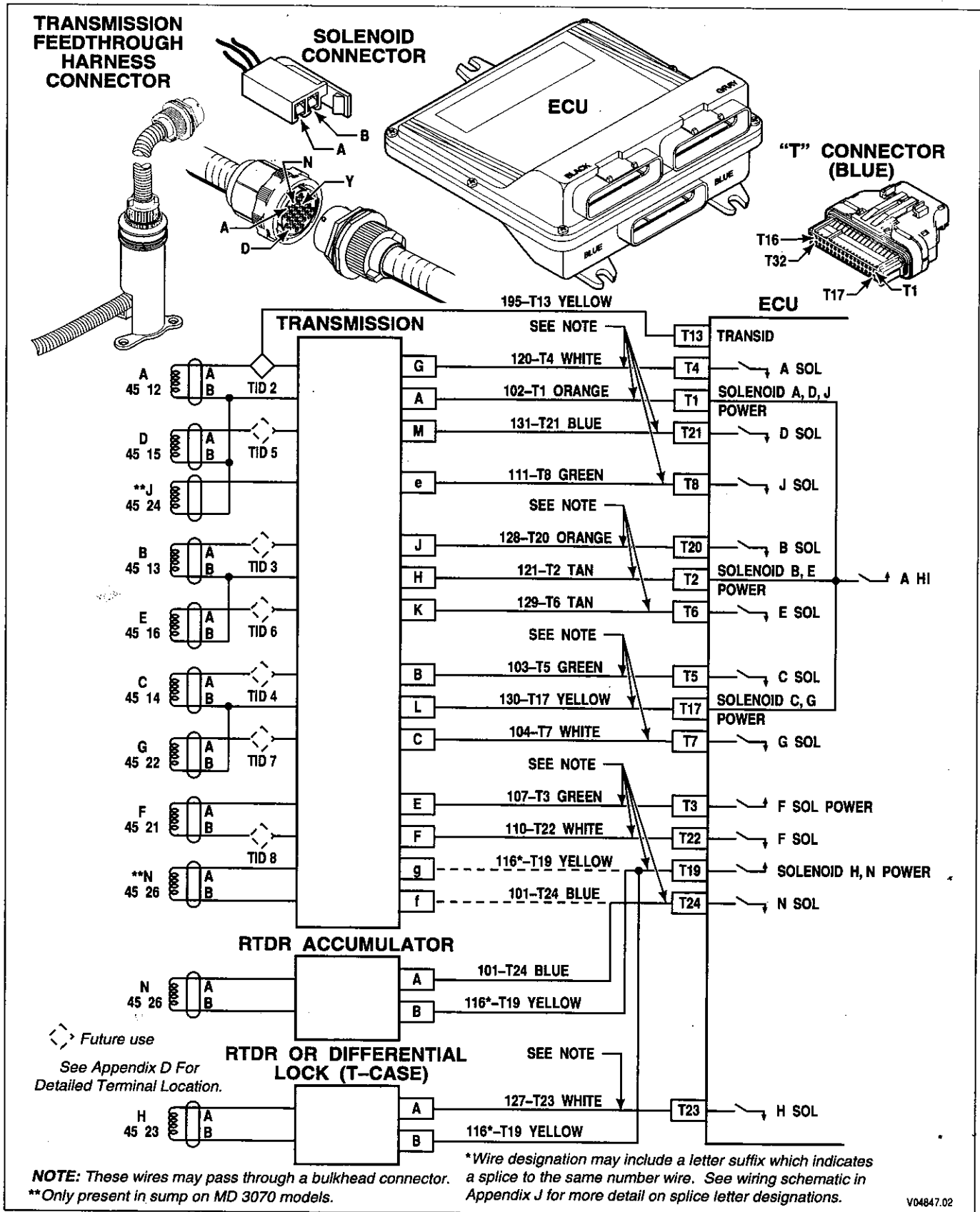

Figure 6-18. Code 45 Schematic Drawing

CODE 45 XX — OPEN CONDITION IN SOLENOID CIRCUIT *(Figure 6-18)*

Main code 45 indicates the ECU has detected either an open circuit condition in a solenoid coil or the wiring to that solenoid. The **DO NOT SHIFT** response is activated when some subcodes are detected, all solenoids are turned off, and the **CHECK TRANS** light is illuminated.

Main Code	Subcode	Meaning
45	12	Open Circuit A Solenoid Circuit
45	13	Open Circuit B Solenoid Circuit
45	14	Open Circuit C Solenoid Circuit
45	15	Open Circuit D Solenoid Circuit
45	16	Open Circuit E Solenoid Circuit
45	21	Open Circuit F Solenoid Circuit
45	22	Open Circuit G Solenoid Circuit
45	23	Open Circuit H Solenoid Circuit
45	24	Open Circuit J Solenoid Circuit
45	26	Open Circuit N Solenoid Circuit

A. Active Indicator Clearing Procedure:

- Power down
- Manual

NOTE: *Intermittent connections or lack of battery-direct power and ground connections may cause this and other codes.*

NOTE: *Before troubleshooting, read Pages 6-15 and 6-16 of Paragraph 6-5. Also, check battery and ECU input voltages.*

PROBING THE CONNECTOR

When testing the control system from the feedthrough connector with the internal harness connected, the resistance of each solenoid can be checked using a VOM. Refer to Figure 6-19 for solenoid resistance values versus temperature.

CODE 45 XX — OPEN CONDITION IN SOLENOID CIRCUIT (Figure 6-18)

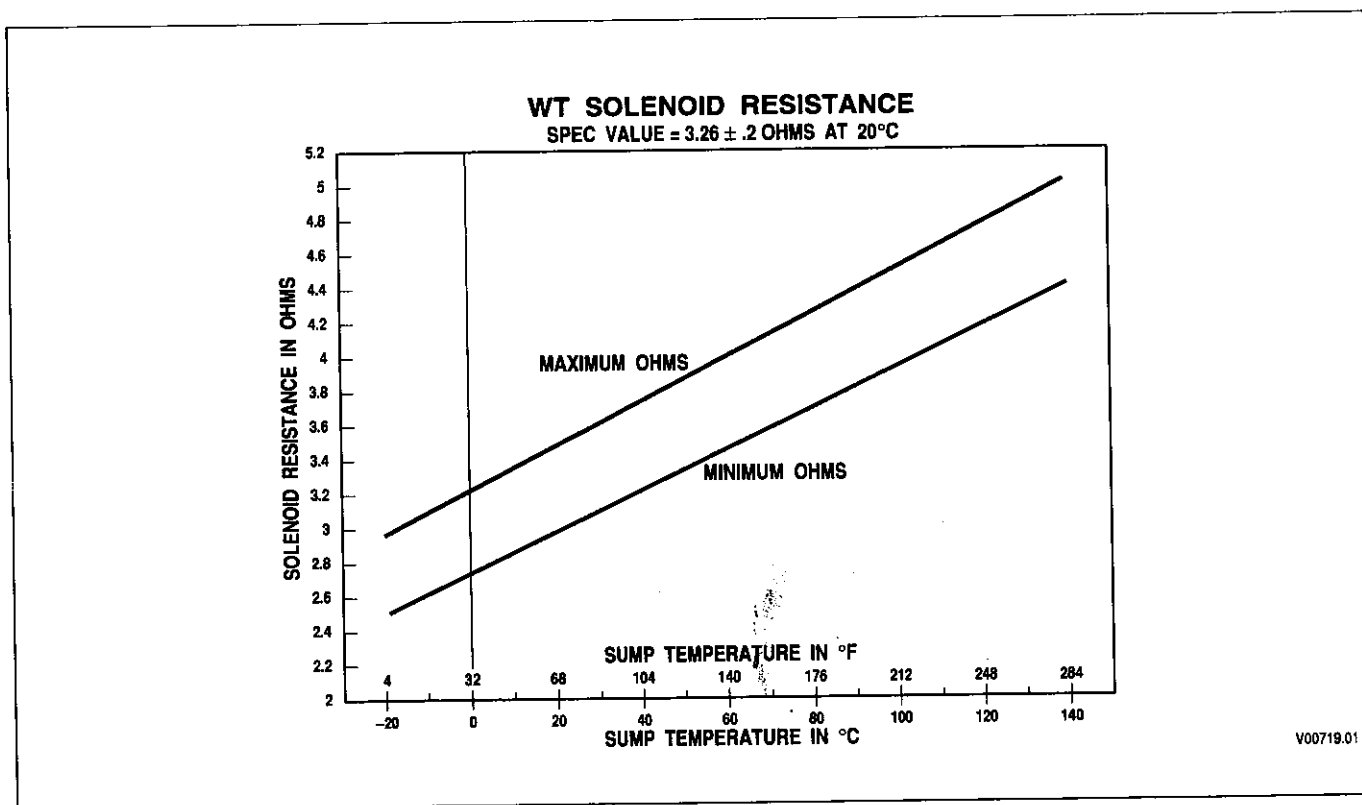

Figure 6-19. Solenoid Resistance vs. Temperature

B. Troubleshooting:

1. Check the transmission connector and make sure it is tightly connected. If the connector is properly connected, disconnect the harness at the feedthrough harness connector and check the terminals in the transmission harness and feedthrough harness connectors. Clean or replace as necessary (Appendix E).
2. If the connector is connected, clean, and not damaged, check the solenoid circuit in the transmission for opens. Refer to the system schematic and/or chart to identify wires in the internal harness which are connected. If the open circuit is found, drain the fluid, remove the control module (see the transmission Service Manual), and isolate the open. The fault will be in the feedthrough harness or the solenoid itself (see Figure 6-1 for solenoid locations).
3. If the open is not found at the transmission connector, disconnect the transmission harness connector at the ECU and inspect the terminals in the connector and the ECU for damage or contamination. Clean or replace as necessary. If the terminals are satisfactory, check the wires of the solenoid circuit in the transmission harness for continuity. If the open is found in one of the wires, isolate and repair it. If this is not feasible, use a spare wire, if available, or provide a new wire (St. Clair P/N 200153 may be used for this purpose). See Appendix E for information on connector/wire repair.
4. If multiple code 45s occur (45 12, 45 13, 45 14, 45 15, 45 16, 45 22, and 45 24), and wiring and solenoids check okay, the A-Hi driver is probably failed open.
5. Replace the ECU. If replacing the ECU corrects the problem, reinstall the original (bad) ECU to confirm that the problem is in the ECU. If the problem recurs, reinstall the new ECU to complete the repair.

CODE 45 XX — OPEN CONDITION IN SOLENOID CIRCUIT (*Figure 6-18*)

6. If code 45 21 occurs repeatedly and the F solenoid and wiring checks okay, the F-Hi or F-Lo driver may be failed open. Follow Step (5) above.
7. If codes 45 23 and 45 26 occur repeatedly and solenoids and wiring check okay, the H and N-Hi driver may be failed open. Follow Step (5) above.
8. If the open is not found in either the transmission or the harness or the ECU drivers, the condition must be intermittent.
9. Drain the fluid, remove the control module, and closely inspect the solenoid and internal harness for damage. Repair or replace as necessary (refer to the transmission Service Manual).
10. If the condition recurs, use a spare wire, if available, or provide a new wire (St. Clair P/N 200153 may be used for this purpose) for the solenoid circuit indicated by the diagnostic code. See Appendix E for information on connector assembly/disassembly.
11. If the condition persists, replace the ECU. If replacing the ECU corrects the problem, reinstall the original (bad) ECU to confirm that the problem is in the ECU. If the original ECU now works, inspect the ECU connectors for any corrosion or damage which may cause an intermittent condition. If the original problem recurs, reinstall the replacement ECU.

CODE 46 XX — OVERCURRENT TO SOLENOIDS

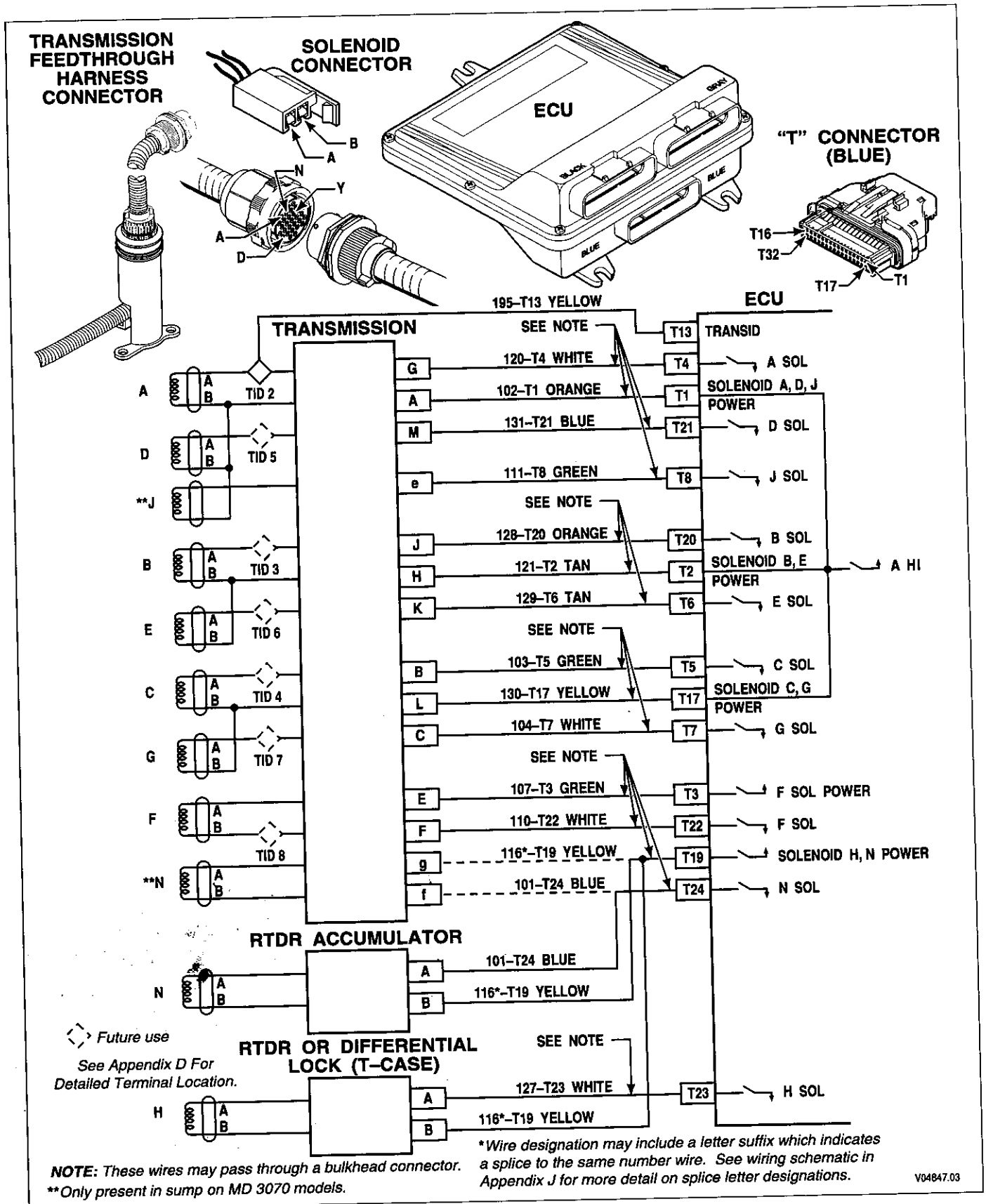

Figure 6-20. Code 46 Schematic Drawing

CODE 46 XX — OVERCURRENT TO SOLENOIDS *(Figure 6-20)*

Main code 46 indicates that an overcurrent condition exists in one of the switches sending power to the transmission control solenoids.

Main Code	Subcode	Meaning
46	21	Overcurrent, F-High solenoid circuit
46	26	Overcurrent, N and H-High solenoid circuit
46	27	Overcurrent, A-High solenoid circuit

A. Active Indicator Clearing Procedure:

- Power down
- Manual

B. Troubleshooting:

1. Probable cause is a wiring problem. A solenoid wire is probably shorted to ground which would cause an overcurrent condition.
2. Follow the troubleshooting steps for code 44 XX.

CODE 51 XX — OFFGOING RATIO TEST DURING SHIFT (TIE-UP TEST)

Main code 51 indicates a failed offgoing ratio test. An offgoing ratio test occurs during a shift and uses turbine and output speed sensor readings to calculate the ratio between them. The calculated speed sensor ratio is then compared to the programmed speed sensor ratio of the commanded range. After a shift is commanded, the ECU, after a period of time, expects the old ratio to be gone. If the ratio does not change properly, the ECU assumes the offgoing clutch did not release. The shift is retried if conditions still exist to schedule the shift. If the second shift is not successfully completed, code 51 XX is set and the ECU returns the transmission to the previous range. Additional codes could be logged for other shifts where "X" indicates the range from and "Y" indicates the range to.

NOTE: *This test is not performed below a calibrated transmission output speed of 200 rpm.*

Main Code	Subcode	Meaning
51	01	Low-1 upshift
51	10	1-Low downshift
51	12	1-2 upshift
51	21	2-1 downshift
51	23	2-3 upshift
51	24	2-4 upshift
51	35	3-5 upshift
51	42	4-2 downshift
51	43	4-3 downshift
51	45	4-5 upshift
51	46	4-6 upshift
51	53	5-3 downshift
51	64	6-4 downshift
51	65	6-5 downshift
51	XY	X-Y upshift or downshift

A. Active Indicator Clearing Procedure:

- Power down
- Manual — except subcodes 35, 42, 43, 45, 53

NOTE: *Before troubleshooting, read Pages 6-15 and 6-16 of Paragraph 6-5. Also, check battery and ECU input voltages.*

NOTE: *Intermittent connections or lack of battery-direct power and ground connections may cause this and other codes.*

B. Troubleshooting:

1. Incorrect fluid level can cause 51 series codes. Allow the vehicle to idle for 3-4 minutes and check the transmission fluid level. If level is not correct, add or drain fluid to correct level.
2. If the fluid level is correct, connect a pressure gauge into the pressure tap for the offgoing clutch indicated by the code (refer to solenoid and clutch chart, Appendix C). Make the shift indicated by the code or use the Pro-Link® diagnostic tool clutch test mode to put the transmission in the off-going and oncoming ranges (refer to Appendix B for clutch pressure check information).

CODE 51 XX — OFFGOING RATIO TEST DURING SHIFT (TIE-UP TEST)

3. If the offgoing clutch stays pressurized, drain the fluid, remove the control module, disassemble the control module and clean it, inspecting for damaged valve body gaskets and stuck or sticky valves. Inspect the transmission for signs of clutch damage indicating the need to remove and overhaul the transmission (refer to the transmission Service Manual).
4. If the problem has not been isolated, replace the solenoid for the offgoing clutch (refer to the transmission Service Manual).
5. If after replacing the solenoid the problem persists, install another ECU. If this corrects the problem, temporarily reinstall the old ECU to verify the repair.
6. If this does not correct the problem, reinstall the original ECU and check for mechanical problems. The clutch may be mechanically held (coned, burned and welded, etc.). It may be necessary to remove the transmission and repair or rebuild as required (see the transmission Service Manual).

CODE 52 XX — OFFGOING C3 PRESSURE SWITCH TEST DURING SHIFT

Main code 52 indicates a failed C3 pressure switch test. When a shift is commanded and C3 is the offgoing clutch, the ECU expects the C3 pressure switch to open within a period of time after the shift is commanded. If the ECU does not see the switch open, it assumes C3 has not released. If conditions for a shift exist, the shift is retried. If the C3 pressure switch still remains closed, the code is logged and the **DO NOT SHIFT** response is commanded. If the code is set during a direction change, neutral with no clutches is commanded, otherwise the transmission is commanded to the previous range. Additional codes could be logged for other shifts where "X" indicates the range from and "Y" indicates the range to.

NOTE: C3 tests are turned off below a calibrated temperature of -32°C (-25°F).

Main Code	Subcode	Meaning
52	01	L-1 upshift
52	08	L-N1 shift
52	32	3-2 downshift
52	34	3-4 upshift
52	54	5-4 downshift
52	56	5-6 upshift
52	71	R-1 shift
52	72	R-2 shift
52	78	R-N1 shift
52	79	R-2 shift (R to NNC to 2)
52	99	N3-N2 shift
52	XY	X-Y shift

A. Active Indicator Clearing Procedure:

- Power down
- Manual

NOTE: Before troubleshooting, read Pages 6-15 and 6-16 of Paragraph 6-5. Also, check battery and ECU input voltages.

NOTE: Intermittent connections or lack of battery-direct power and ground connections may cause this and other codes.

B. Troubleshooting:

1. Use the Pro-Link[®] diagnostic tool to check the state of the C3 pressure switch.
2. Check the C3 pressure switch wiring for a short-to-power or a switch stuck closed (refer to code 32 XX). If a short is found, isolate and repair; or replace the switch if it is stuck closed.
3. If a fault is not found with the C3 pressure switch or circuitry, connect a pressure gauge to the C3 pressure tap.
4. Drive the vehicle to make the shift indicated by the code or use the DDR clutch test mode. Compare actual C3 pressure value with the table of specifications in Appendix B.

CODE 52 XX — OFFGOING C3 PRESSURE SWITCH TEST DURING SHIFT

5. If C3 is being held on hydraulically (C3 remains pressurized), drain the fluid, remove the control module, disassemble and clean the control module, checking for damaged valve body gaskets or stuck and sticky valves (see the transmission Service Manual).
6. If the problem recurs, use a spare wire, if available, or provide a new wire (St. Clair P/N 200153 may be used for this purpose) for the C3 pressure switch in the external harness. See Appendix E for connector service information.
7. If the problem again recurs, replace the C solenoid (refer to the transmission Service Manual).
8. If the condition persists, replace the ECU. If replacing the ECU corrects the problem, reinstall the original (bad) ECU to confirm that the problem is in the ECU. If the original ECU now works, inspect the ECU connectors for any corrosion or damage which may cause an intermittent condition. If the original problem recurs, reinstall the replacement ECU.

CODE 53 XX — OFFGOING SPEED TEST (DURING SHIFT)

Main code 53 indicates a failed offgoing speed test. The speed test during a shift is designed to ensure neutral is attained during shifts to neutral. This test compares engine speed to turbine speed. If neutral is selected and turbine speed is found to be much lower than engine speed, the ECU sees this as neutral not being attained. The transmission is commanded to Neutral with No Clutches and code 53 XX is set. Additional codes could be logged for other shifts where "X" indicates the range from and "Y" indicates the range to.

NOTE: *This test is not performed if neutral output is below 200 rpm or when temperatures are below a calibrated 0°C (32°F).*

Main Code	Subcode	Meaning
53	08	L-N1 shift
53	18	1-N1 shift
53	28	2-N1 shift
53	29	2-N2 shift
53	38	3-N1 shift
53	39	3-N3 shift
53	48	4-N1 shift
53	49	4-N3 shift
53	58	5-N1 shift
53	59	5-N3 shift
53	68	6-N1 shift
53	69	6-N4 shift
53	78	R-N1 shift
53	99	N3-N2 or N2-N3 shift
53	XY	X-Y shift

A. Active Indicator Clearing Procedure:

- Power down
- Manual — subcodes 78 and 99 only

NOTE: *Before troubleshooting, read Pages 6-15 and 6-16 of Paragraph 6-5. Also, check battery and ECU input voltages.*

NOTE: *Intermittent connections or lack of battery-direct power and ground connections may cause this and other codes.*

B. Troubleshooting:

1. Be sure the transmission is warm and the fluid level is correct. Correct transmission fluid level as necessary.
2. Using the DDR, check the engine and turbine speed sensor signals under steady conditions. If a tachometer is available, compare the tachometer reading with the engine rpm reading on the diagnostic tool. Check signals in neutral, at idle, high idle, and maximum no load rpm. If a signal is erratic, check sensor wiring for opens, shorts, and shorts-to-ground (refer to code 22 XX). Check all connections for dirt and corrosion. If wiring problems are found, repair or replace as necessary. See Appendix E for connector service information.

CODE 53 XX — OFFGOING SPEED TEST (DURING SHIFT)

3. If fluid and wiring are satisfactory, install a pressure gauge in the pressure tap for the offgoing clutch. Make the shift indicated by the code using the clutch test mode of the Pro-Link[®] diagnostic tool. If the pressure gauge shows clutch pressure (above 55 kPa or 8 psi) remains in the offgoing clutch, drain the fluid and remove the control module (see the transmission Service Manual). Disassemble and clean the control module and check for damaged valve body gaskets and stuck or sticky valves, particularly latch valves and solenoid second-stage valves.
4. If excessive clutch pressure is not remaining in the offgoing clutch, replace the engine speed sensor and the turbine speed sensor (refer to the transmission Service Manual).
5. If the control module is removed to replace the turbine speed sensor (MD, B 300, B 400), clean the control module and inspect for stuck or sticky valves (particularly the latch valves and solenoid G second stage valve). Check the rotating clutch drum to which the turbine speed sensor is directed for damage, contamination, or signs of contact between the drum and the sensor.
6. If the problem recurs, replace the solenoid(s) for the offgoing clutch(es) (refer to the transmission Service Manual).
7. If the problem again recurs, the offgoing clutch must be held on mechanically (coned, burned, etc.). Remove the transmission and repair or rebuild as necessary (see the transmission Service Manual).
8. If the condition persists, replace the ECU. If replacing the ECU corrects the problem, reinstall the original (bad) ECU to confirm that the problem is in the ECU. If the original ECU now works, inspect the ECU connectors for any corrosion or damage which may cause an intermittent condition. If the original problem recurs, reinstall the replacement ECU.

CODE 54 XX — ONCOMING SPEED TEST (AFTER SHIFT)

Main code 54 indicates a failed oncoming ratio test. The ratio test after a shift is failed when the ECU has commanded the end of a shift and has not seen the transmission shift into the target range (comparing turbine and output speeds). Erratic readings from speed sensors are a likely cause of an oncoming ratio test failure. If conditions for a shift still exist, the shift will be retried one more time. If the ratio test is still not met, a code is logged and the **DO NOT SHIFT** response is commanded. If the code is set during a direction change, Neutral with No Clutches is commanded, otherwise the transmission is commanded to the previous range. **Code 54 12 can also be caused by the ECU being calibrated for a close ratio transmission and installed with a wide ratio transmission, or vice versa.** Additional codes could be logged for other shifts where “X” indicates the range from and “Y” indicates the range to.

NOTE: *This test is not performed below a calibrated transmission output speed of 200 rpm.*

Main Code	Subcode	Meaning
54	01	L-1 upshift
54	07	L-R shift
54	10	1-L downshift
54	12	1-2 upshift — incorrect calibration, wide ratio vs. close ratio
54	17	1-R shift
54	21	2-1 downshift
54	23	2-3 upshift
54	24	2-4 upshift
54	27	2-R shift
54	32	3-2 downshift
54	34	3-4 upshift
54	35	3-5 upshift
54	42	4-2 downshift
54	43	4-3 downshift
54	45	4-5 upshift
54	46	4-6 downshift
54	53	5-3 downshift
54	54	5-4 downshift
54	56	5-6 upshift
54	64	6-4 downshift
54	65	6-5 downshift
54	70	R-L shift
54	71	R-1 shift
54	72	R-2 shift
54	80	N1-L shift
54	81	N1-1 shift
54	82	N1-2 shift
54	83	N1-3 shift
54	85	N1-5 shift
54	86	N1-6 shift
54	92	N2-2 shift
54	93	N3-3 shift
54	95	N3-5 shift
54	96	N4-6 shift
54	XY	X to Y shift

CODE 54 XX — ONCOMING SPEED TEST (AFTER SHIFT)**A. Active Indicator Clearing Procedure:**

- Power down
- Manual

NOTE: *Before troubleshooting, read Pages 6–15 and 6–16 of Paragraph 6–5. Also, check battery and ECU input voltages.*

NOTE: *Intermittent connections or lack of battery-direct power and ground connections may cause this and other codes.*

B. Troubleshooting:

1. After the transmission is at operating temperature, allow the vehicle to idle on level ground for 3–4 minutes. Check transmission fluid level. If improper fluid level is found, correct as necessary. Improper fluid level could be the cause of the code (not enough or too much fluid may produce inadequate clutch pressure).
2. Connect a pressure gauge and check main pressure. If pressure is not adequate, the pump is possibly worn. See Appendix B for main pressure specifications.
3. If the fluid level is correct, check the turbine and output speed sensors for accurate, steady signals using the diagnostic tool (check with vehicle stopped and in range to confirm a zero speed reading from the turbine and output speed sensors). Check the wiring for opens and shorts (refer to code 22 XX) and the sensor coils for proper resistance. If problems are found, repair or replace as necessary. Remove speed sensor and check for loose tone wheel.
4. If sensor and wiring resistance are acceptable, connect a pressure gauge(s) to the pressure tap for the oncoming clutches indicated by the code (refer to solenoid and clutch chart in Appendix C). Make the shift indicated by the code by operating the vehicle or by using the diagnostic tool's clutch test mode.
5. If the clutch pressure does not show on the gauge(s), the control module is probably not commanding the clutch on. Drain the fluid and remove the control module (see the transmission Service Manual). Disassemble and clean the control module, inspect for stuck or sticking valves.
6. Internal leakage is indicated by the clutch pressure gauge showing that pressure is being sent to the clutch but the clutch fails to hold. The fault may be: missing or damaged face seals, burnt clutch, leaking piston sealrings, or damaged control module gaskets. Drain the fluid, remove the control module (refer to the transmission Service Manual), and inspect the face seals and control module gaskets. If the seals and gaskets are satisfactory, replace the solenoid(s) indicated by the code. If replacing the solenoid does not eliminate the code, remove the transmission and repair as necessary.
7. If clutch pressures are correct and the clutch appears to be holding, replace the output and turbine speed sensors (refer to the transmission Service Manual for the proper procedure).
8. If the problem recurs, use the diagnostic tool to check the speed sensor signals for erratic readings. Possible causes of erratic speed readings are: loose sensors, intermittent contact in the wiring, vehicle-induced vibrations, or speed sensor wiring that is not a properly twisted-pair. If necessary, use a twisted-pair for a new speed sensor circuit — Service Harness Twisted Pair P/N 200153 is available from St. Clair Technologies for this purpose.
9. If the condition persists, replace the ECU. If replacing the ECU corrects the problem, reinstall the original (bad) ECU to confirm that the problem is in the ECU. If the original ECU now works, inspect the ECU connectors for any corrosion or damage which may cause an intermittent condition. If the original problem recurs, reinstall the replacement ECU.

CODE 55 XX — ONCOMING C3 PRESSURE SWITCH (AFTER SHIFT)

Main code 55 indicates the C3 clutch is the oncoming clutch in a shift and the C3 pressure switch did not close at the end of the shift. When this code is set, the **DO NOT SHIFT** response and **Neutral with No Clutches** is commanded. On the N1 to R shift the transmission is commanded to the previous range. Additional codes could be logged for other shifts where "X" indicates the range from and "Y" indicates the range to.

NOTE: *When an ECU with a version 8 or 8A calibration is used with a pre-TransID transmission, 55 XX codes are set because the ECU sees wire 195 is open. To correct this condition, convert to a TID 1 internal harness or install Adapter P/N 200100 available from St. Clair Technologies.*

Further TransID (TID) information is in Paragraph 1-10.

Main Code	Subcode	Meaning
55	07*	Oncoming C3PS (after shift), L-R shift
55	17*	Oncoming C3PS (after shift), 1-R shift
55	27*	Oncoming C3PS (after shift), 2-R shift
55	87	Oncoming C3PS (after shift), N1-R shift
55	97	Oncoming C3PS (after shift), N1-L to R shift
55	XY	Oncoming C3PS (after shift), X to Y shift

***NOTE:** *When sump temperature is below 10°C (50°F), and transmission fluid is C4 (not DEXRON), follow this procedure when making directional change shifts:*

- *To shift from forward to reverse; select N (Neutral) and then R (Reverse).*
- *Failure to follow this procedure may cause illumination of the CHECK TRANS light and then transmission operation will be restricted to N(Neutral).*

A. Active Indicator Clearing Procedure:

- Power down
- Manual — subcode 87 only

NOTE: *Intermittent connections or lack of battery-direct power and ground connections may cause this and other codes.*

NOTE: *Check battery and ECU input voltages before troubleshooting.*

B. Troubleshooting:

NOTE: *Do not bring the transmission to operating temperature if the problem occurs at sump temperatures below that level. Do troubleshooting at the temperature level where the problem occurs.*

1. After the transmission is at operating temperature, allow vehicle engine to idle on level ground for 3-4 minutes. Check transmission fluid level. If improper fluid level is found, correct as necessary. Improper fluid level could be the cause of the code (not enough or too much fluid may produce inadequate clutch pressure).
2. Connect a pressure gauge and check main pressure. If pressure is not adequate, the pump is possibly worn. See Appendix B for main pressure specifications.

CODE 55 XX — ONCOMING C3 PRESSURE SWITCH (AFTER SHIFT)

3. If fluid level and main pressure are adequate, connect a pressure gauge to the C3 pressure tap on the transmission and make the shift indicated by operating the vehicle using the Pro-Link[®] diagnostic tool's CLUTCH TEST MODE.

NOTE: *When using the CLUTCH TEST MODE on the Pro-Link[®], be sure to use the correct pressure specification. If testing is done with the vehicle stopped, the lockup clutch is not applied, so use the clutch pressure specification for converter operation (see Appendix B; pressure in 3C would be the same as in 2C). If testing is done with the vehicle moving, the lockup clutch may be applied depending upon the vehicle speed and throttle position. Be sure to use the clutch pressure specification for lockup operation (see Appendix B).*

4. If, when making the shift and producing the code, the C3 clutch does not show any pressure, drain the fluid and remove the control module (refer to the transmission Service Manual). Disassemble, clean, and inspect the control module for stuck or sticky valves (particularly the "C" solenoid second stage valve and C-1 latch valve). If no obvious problems are found, replace the "C" solenoid and reassemble (see Figure 6-1 for location of the "C" solenoid).
5. If the gauge shows inadequate pressure being sent to the clutch, the clutch is probably worn, has leaking piston or face seals, or the control module gaskets are damaged. See Appendix B for clutch pressure specification. Drain the fluid, remove the control module and inspect the face seals and valve body gaskets. If the face seals or control module gaskets are not damaged, remove and repair the transmission (refer to the transmission Service Manual for repair procedure).
6. If the gauge shows adequate clutch apply pressure, the problem is with the C3 pressure switch or its wires. Check the C3 pressure switch wires in the transmission harness for opens, shorts, or shorts-to-ground (see code 32 XX). If found, isolate and repair the C3 pressure switch circuit. See Appendix E for connector service information.

NOTE: *A leakage problem may be temperature related. Be sure to check pressures at the sump temperature where the problem occurred.*

7. If the problem is not in the transmission harness, drain the fluid and remove the control module. Check the feedthrough harness assembly for opens. If wiring problems are found, repair as necessary (refer to Appendix E). If no wiring problems are found, replace the C3 pressure switch (see Figure 6-1 for the location). Refer to the transmission Service Manual for proper procedure.
8. If the condition persists, replace the ECU. If replacing the ECU corrects the problem, reinstall the original (bad) ECU to confirm that the problem is in the ECU. If the original ECU now works, inspect the ECU connectors for any corrosion or damage which may cause an intermittent condition. If the original problem recurs, reinstall the replacement ECU.

CODE 56 XX — RANGE VERIFICATION RATIO TEST (BETWEEN SHIFTS)

Main code 56 indicates a failed range verification speed sensor ratio test. The ratio test occurs after a shift and determines if a clutch has lost torque carrying capability. If output speed is above programmed output speed for a range but the correct speed sensor ratio is not present, the **DO NOT SHIFT** response is commanded and a range which can carry the torque without damage is commanded or attempted. Turbine and output speed sensor readings are used to calculate the actual ratio that is compared to the commanded ratio. **Main code 56 can also be caused by the ECU being calibrated for a close ratio transmission and installed with a wide ratio transmission, or vice versa.**

Main Code	Subcode	Meaning
56	00	Range verification ratio test (between shifts) L
56	11	Range verification ratio test (between shifts) 1
56	22	Range verification ratio test (between shifts) 2
56	33	Range verification ratio test (between shifts) 3
56	44	Range verification ratio test (between shifts) 4
56	55	Range verification ratio test (between shifts) 5
56	66	Range verification ratio test (between shifts) 6
56	77	Range verification ratio test (between shifts) R

A. Active Indicator Clearing Procedure:

- Power down
- Manual — subcodes 11, 44, 66, 77 only

NOTE: *Before troubleshooting, read Pages 6–15 and 6–16 of Paragraph 6–5. Also, check battery and ECU input voltages.*

NOTE: *Intermittent connections or lack of battery-direct power and ground connections may cause this and other codes.*

B. Troubleshooting:

1. After the transmission is at operating temperature, allow vehicle to idle on level ground for 3–4 minutes. Check the transmission fluid level. If improper fluid level is found, correct as necessary. Improper fluid level could be the cause of the code. Not enough or too much fluid may produce inadequate clutch pressure.
2. Connect a pressure gauge and check main pressure. If the pressure is not adequate, the pump is probably worn. See Appendix B for main pressure specifications.
3. If main pressure is adequate, check clutch pressure for the range indicated by following the procedure in Appendix B. The transmission range indicated by the trouble code can be found by referring to the solenoid and clutch chart in Appendix C. Drive the vehicle or use the diagnostic tool's clutch test mode and check clutch pressure.
4. If a clutch is leaking pressure, drain the fluid, remove the control module and check for damaged control module gaskets and stuck or sticking valves (see the transmission Service Manual). Also look for damaged or missing face seals. If no problems are found, replace the solenoids for the clutches used in the range indicated by the code.
5. If replacing solenoids does not correct the pressure problem, a worn clutch or worn piston seals are probably the source of the pressure leak. Remove the transmission and repair or replace as necessary (refer to the transmission Service Manual).

CODE 56 XX — RANGE VERIFICATION RATIO TEST (BETWEEN SHIFTS)

6. This code requires accurate output and turbine speed readings. If there were no transmission problems detected, use the diagnostic tool and check the speed sensor signals for noise (erratic signals) from low speed to high speed in the range indicated by the code.
7. If a noisy sensor is found, check the resistance of the sensor (300 ± 30 Ohms, refer to the code 22 XX temperature variation chart) and its wiring for opens, shorts, and shorts-to-ground (refer to code 22 XX). Carefully check the terminals in the connectors for corrosion, contamination, or damage. Ensure the wiring to the sensors is a properly twisted wire pair. Replace a speed sensor if its resistance is incorrect. Isolate and repair any wiring problems. (Use a twisted-pair if a new speed sensor circuit is needed — Service Harness Twisted Pair P/N 200153 is available from St. Clair Technologies for this purpose.)
8. If no apparent cause for the code can be found, replace the turbine and output speed sensors (refer to the transmission Service Manual for proper procedure).
9. If the condition persists, replace the ECU. If replacing the ECU corrects the problem, reinstall the original (bad) ECU to confirm that the problem is in the ECU. If the original ECU now works, inspect the ECU connectors for any corrosion or damage which may cause an intermittent condition. If the original problem recurs, reinstall the replacement ECU.

CODE 57 XX — RANGE VERIFICATION C3 PRESSURE TEST (BETWEEN SHIFTS)

Main code 57 indicates failure of the range verification C3 pressure switch test. This test determines if the C3 pressure switch is closed when it should be open. The test occurs when a range is commanded that does not use the C3 clutch (neutral, 1, 2, 4, and 6). The code is set if the C3 pressure switch is closed when it should be open. If C3 clutch comes on when not needed, three clutches are applied and a transmission tie-up occurs. The ECU will command a range which does use the C3 clutch and activate the **DO NOT SHIFT** response.

Main Code	Subcode	Meaning	Replace Solenoid
57	11	Range verification C3 pressure switch while in 1st	B
57	22	Range verification C3 pressure switch while in 2nd	C
57	44	Range verification C3 pressure switch while in 4th	C
57	66	Range verification C3 pressure switch while in 6th	A
57	88	Range verification C3 pressure switch while in N1	C
57	99	Range verification C3 pressure switch while in N2 or N4	C

A. Active Indicator Clearing Procedure:

- Power down
- Manual

NOTE: Before troubleshooting, read Pages 6–15 and 6–16 of Paragraph 6–5. Also, check battery and ECU input voltages.

NOTE: Intermittent connections or lack of battery-direct power and ground connections may cause this and other codes.

B. Troubleshooting:

1. Disconnect the harness from the transmission. Check the C3 pressure switch circuit at the feedthrough harness connector for continuity (refer to code 32 XX).
2. Continuity at the feedthrough harness connector indicates the C3 pressure switch is closed or the C3 circuit is shorted together. Drain the fluid, remove the control module (refer to the transmission Service Manual), and isolate the short. The fault is either a shorted feedthrough harness or stuck C3 pressure switch. Repair or replace as necessary.
3. If there is no continuity at the transmission, disconnect the transmission harness connector from the ECU and check the C3 pressure switch wires in the transmission harness for shorts. Use the system wiring diagram to identify wires which are connected. If a shorted C3 pressure switch circuit in the external harness is found, isolate and repair.
4. If the C3 pressure switch or circuit is not shorted either in the transmission or the external harness, connect a pressure gauge in the C3 pressure tap (refer to Appendix B for pressure tap location). Drive the vehicle in the range indicated by the code or use the diagnostic tool's clutch test mode to attain that range.
5. If the gauge shows C3 pressure is present in the range indicated by the code, drain the fluid and remove the control module (refer to the transmission Service Manual). Check for damaged valve body gaskets or stuck or sticking valves. Repair or replace as necessary. If no obvious defects are found, replace the listed solenoid.
6. If the gauge shows C3 pressure is not present in the range indicated by the code, drain the fluid and remove the control module (refer to the transmission Service Manual). Replace the C3 pressure switch.
7. If the condition persists, replace the ECU. If replacing the ECU corrects the problem, reinstall the original (bad) ECU to confirm that the problem is in the ECU. If the original ECU now works, inspect the ECU connectors for any corrosion or damage which may cause an intermittent condition. If the original problem reoccurs, reinstall the replacement ECU.

CODE 61 XX — RETARDER OIL TEMPERATURE HOT

Main code 61 indicates the ECU has detected a hot fluid condition in the output retarder. Table 6-7 shows what actions are taken by the ECU at elevated retarder temperatures.

Possible causes (but not all causes) for hot fluid are:

1. Prolonged retarder use.
2. TID2 transmission with ECU prior to Version 8A.
3. Low fluid level.
4. High fluid level.
5. A retarder apply system that allows the throttle and retarder to be applied simultaneously.
6. Cooler inadequately sized for retarder.

If the validity of the hot fluid diagnosis is in question, temperature can be checked by using a temperature gauge at the retarder-out port or by reading retarder temperature with the Pro-Link® diagnostic tool. Another method of checking retarder temperature is to remove the "T" connector at the ECU and measure resistance (Ohms) between terminals T28 and T25. Compare the resistance value to the value in Figure 6-21 to see if the result is within the expected operating range. For TID2 thermistors, see Appendix Q for resistance versus temperature table.

Table 6-7. Transmission Retarder Operation as a Function of Temperature

Description	Version 8*
MD and HD Retarder, Light On	166°C (330°F)
MD and HD Retarder, Light Off	159°C (318°F)
MD and HD Retarder, Set Hot Code (61 00)	168°C (335°F)
MD and HD Retarder, Clear Active Indicator	162°C (323°F)
MD and HD Retarder, Capacity Reduction	149–166°C (300–330°F)
MD and HD Retarder, Reduced Capacity (retarder light begins flashing)	146°C (295°F)
MD and HD Retarder, Reduced Capacity (retarder light stops flashing)	143°C (289°F)
MD and HD Retarder, Auto Preselect On (after 12 seconds of retarder apply at retarder temperature shown — range to be preselected is a customer calibratable value). Auto Preselect remains on until retarder is deactivated.	143°C (289°F)
MD and HD Retarder, Auto Preselect On (after 12 seconds of retarder apply and engine water temperature shown (actual value is a customer calibratable value which must be approved by the Allison calibration committee)). Auto Preselect remains on until retarder is deactivated.	82–124°C (180–255°F)
MD and HD Retarder, Flashing Retarder Temperature Light Begins (shows that preselect downshifts are invoked)	140°C (284°F)
MD and HD Retarder, Flashing Retarder Temperature Light Stops (closed throttle downshifts not preselected)	137°C (279°F)
* Calibration values are subject to change.	

NOTE: Use the Pro-Link® diagnostic tool to determine the software version being used.

CODE 61 XX — RETARDER OIL TEMPERATURE HOT

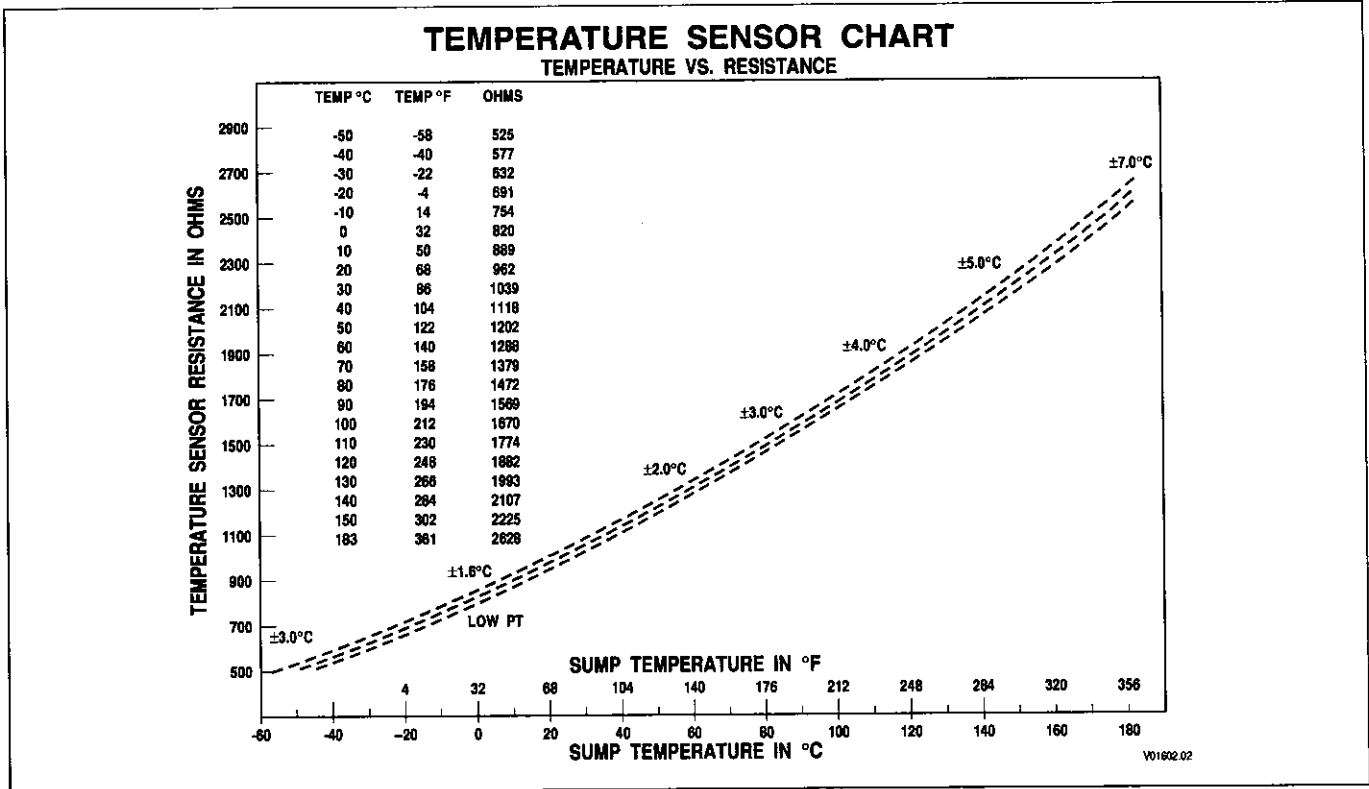

Figure 6-21. Temperature Sensor Chart (Sensors Prior to TID 2)

The retarder temperature sensor is located externally on the HD retarder housing and under the plate on the MD retarder housing. When retarder temperature reaches a preset level, a retarder hot temperature light is illuminated.

DIAGNOSTIC CODES

NOTES

CODE 62 XX — RETARDER TEMPERATURE SENSOR

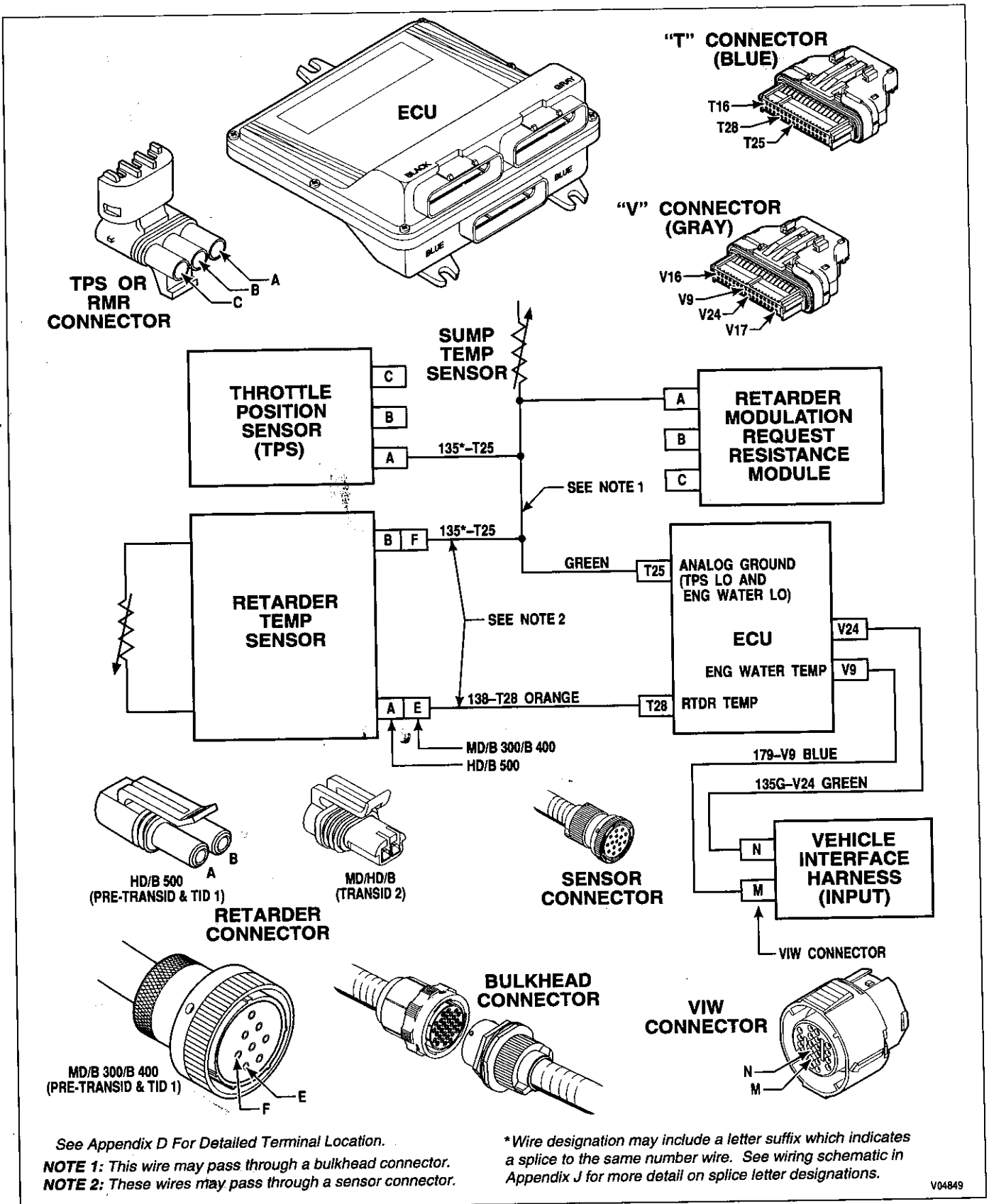

Figure 6-22. Code 62 Schematic Drawing

CODE 62 XX — RETARDER TEMPERATURE SENSOR (Figure 6-22)

NOTE: When an ECU with a version 8 calibration is used with a TransID 2 transmission, 62 XX codes are set because the ECU does not have the proper calibrations for the TID 2 thermistors. The ECU calibration must be updated to version 8A.

TransID (TID) information related to thermistor changes is in Paragraph 1-10 and detailed troubleshooting information for TID 2 thermistors is shown in Appendix Q.

Main code 62 indicates the retarder temperature sensor or engine coolant sensor or circuitry is providing a signal outside the usable range of the ECU. Main code 62 can be the result of a hardware failure or an actual extremely high or low temperature condition.

Main Code	Subcode	Meaning
62	12	Retarder temperature sensor failed low (-45°C; -49°F)
62	23	Retarder temperature sensor failed high (178°C; 352°F)
62	32	Engine coolant sensor failed low
62	33	Engine coolant sensor failed high

A. Active Indicator Clearing Procedure:

- Power down
- Manual
- Self-clearing

NOTE: Before troubleshooting, read Pages 6-15 and 6-16 of Paragraph 6-5. Also, check the transmission fluid level.

B. Troubleshooting:

NOTE: A combination of codes 62 23, 33 23, and 21 23 indicates a problem with one of the branches of the common ground wire (wire 135) between the throttle and temperature sensors.

NOTE: Code 62 12 can be caused when the +5V power line (wire 124) is shorted to ground or open. Wire 124 also provides power for the OLS, TPS, RMR, sump temperature sensor, and shift selectors and is present in all three ECU connectors.

1. Check the retarder temperature or engine coolant temperature with a DDR. If a DDR is not available, use the shift selector display to determine if the code is active (cycle the ignition on and off at least once since the code was logged to clear the code's active indicator). If a condition that is unreasonable for the current conditions exists, go to Step (3).
2. If Step (1) reveals that the extreme temperature indication is no longer present, the temperature limit could have been reached due to operational or ambient temperature extremes. Proceed cautiously as it is unlikely there is a sensor hardware fault.
3. Remove the connector at the ECU. Measure resistance between harness terminals T25 and T28 or between harness terminals V9 and V24. Compare resistance value to chart (see Figure 6-21) to see if reading is within expected operating range.
4. Disconnect the sensor connector and remove the connector at the ECU. Check the sensor and the ECU terminals for dirt, corrosion, and damage. Clean or replace as necessary (refer to Appendix E).

CODE 62 XX — RETARDER TEMPERATURE SENSOR (*Figure 6-22*)

5. Check the temperature sensor circuit for opens (code 62 23 or 62 33), shorts between wires, and short-to-ground (code 62 12 or 62 32). If a wiring problem is found, isolate and repair. See Appendix E for connector service information.
6. If no wiring problem is found, replace the retarder or engine coolant temperature sensor (refer to transmission or vehicle Service Manual for proper procedure).
7. If the problem recurs, use a spare wire, if available, or provide a new wire (St. Clair P/N 200153 may be used for this purpose) for the retarder or engine coolant temperature circuit. See Appendix E for connector service information.
8. If the condition continues to recur, replace the ECU. If replacing the ECU corrects the problem, reinstall the original (bad) ECU to confirm that the problem is in the ECU. If the original ECU now works, inspect the ECU connectors for any corrosion or damage which may cause an intermittent condition. If the original problem recurs, reinstall the replacement ECU.

CODE 63 XX — INPUT FUNCTION FAULT

Code 63 00 is set when one of the two inputs for an input function Auxiliary Function Range Inhibit (Special) is in a different state (on or off) from the other input for longer than two minutes. When this condition is detected, code 63 00 is set. The transmission will not be inhibited in shifting from neutral to range.

Main Code	Subcode	Meaning
63	00	Auxiliary Function Range Inhibit (Special) inputs states are different
63	26	Kickdown input failed on (software version 8 only)
63	40	Service brake status failed on
63	41	Pump/pack and a neutral general purpose input

Subcode 26 is set when this function (Kickdown) is selected by calibration, the calibration designated input is active for a calibration time, and throttle position is less than the calibration value defined. The kickdown shift schedule is inhibited when subcode 26 is active. The service indicator will be turned on if it is selected by the calibration. The kickdown shift schedule is not inhibited, the code is cleared and the service indicator will be turned off if the kickdown input remains inactive for the calibration time period while throttle position is less than the calibration value. This diagnostic and code has been removed from software version 8A.

Subcode 40 is set when this function (Service Brake Status) is selected by calibration, and the specified input remains active for a calibration number of consecutive acceleration events. The service indicator will be turned on if it is selected by the calibration. A vehicle acceleration event is defined as an increase in transmission output speed from 1 rpm to a calibration value. The operation of the Automatic Neutral For Refuse Packer will be limited when this code is active. The active inhibit for this code is self-cleared and the service indicator will be turned off if the designated input for the Service Brake Status function becomes inactive.

Subcode 41 is set when the states of the calibration inputs are different for a calibration number of consecutive updates. The inputs in this case are Pump/Pack Enable and Automatic Neutral For Refuse Packer. The service display will also be turned ON if selected by calibration.

A. Active Indicator Clearing Procedure:

- Power down
- Manual — subcodes 26, 40, and 41
- Self-clearing — subcodes 26 and 40

B. Troubleshooting:

1. Code 63 00
 - a. Use the DDR to identify the two input wires programmed with Auxiliary Function Range Inhibit (Special). Inspect the input wiring, connectors, and switches to determine why the input states are different. Correct any problems which are found.
 - b. If the condition persists, replace the ECU. If replacing the ECU corrects the problem, reinstall the original (bad) ECU to confirm that the problem is in the ECU. If the original ECU now works, inspect the ECU connectors for any corrosion or damage which may cause an intermittent condition. If the original problem recurs, reinstall the replacement ECU.
2. Code 63 26

Inspect kickdown switch circuit.
3. Code 63 40

Inspect service brake status switch circuit.
4. Use the DDR to identify the two wires associated with the input functions for Pump/Pack Enable and Automatic Neutral For Refuse Packer. Inspect the input wiring, connectors, and switches to determine why the input states are different. Correct problems which are found. There is further information on these input functions on pages P-25, P-26, P-29 and P-30.

CODE 64 XX — RETARDER MODULATION REQUEST DEVICE FAULT

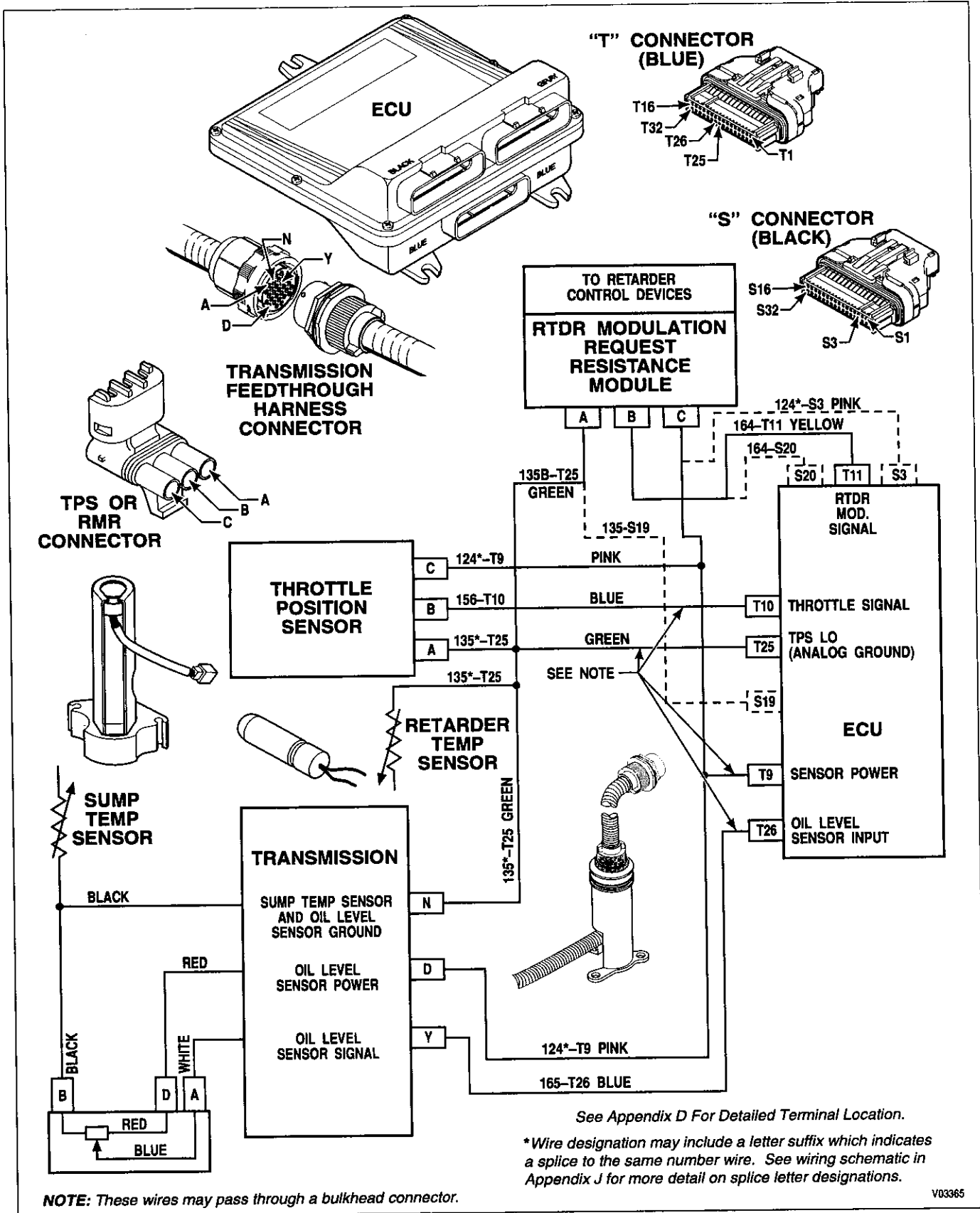

Figure 6-23. Code 64 Schematic Drawing

V03365

CODE 64 XX — RETARDER MODULATION REQUEST DEVICE FAULT (Figure 6-23)

Main code 64 indicates the ECU has detected a voltage signal from the retarder modulation request sensor (consisting of a module and a retarder control device) in either the high or low error zone. These codes can be caused by faulty wiring, faulty connections to the resistance module or retarder control device, a faulty resistance module, a faulty retarder control device, or a faulty ECU. Power wire 124 and ground wire 135 for the retarder modulation request sensor are a common power and ground with the TPS and OLS devices. A short-to-ground on the common power wire causes a “sensor failed low” code for the other devices (codes 21 12, and 14 12). An open or a short-to-ground on retarder modulation request sensor signal wire 164 results in a code 64 12 only.

A TPS failure changes the status of the output retarder. The retarder is enabled by the Service Brake Status (wire 137) when a TPS code is active (21 XX). If a code 63 40 is also active, the Service Brake Status (wire 137) is ignored and the retarder will not work. Retarder response problems may not cause retarder modulation request sensor diagnostic codes. If response questions occur, test the retarder control devices for proper voltage signals at each of the percentage of retarder application settings. Table 6-8 contains the voltage measurements for each device’s application percentage and resistances measured across terminals A and C of the retarder request sensor. Use test wiring harness J 41339 when conducting voltage tests.

Main Code	Subcode	Meaning
64	12	Retarder Modulation Request sensor failed Low (14 counts and below)
64	23	Retarder Modulation Request sensor failed High (232 counts and above)

A. Active Indicator Clearing Procedure:

- Power down

NOTE: Before troubleshooting, read Pages 6-15 and 6-16 of Paragraph 6-5. Also, check battery and ECU input voltages.

NOTE: Intermittent connections or lack of battery-direct power and ground connections can cause this and other electronic control codes.

B. Troubleshooting:

NOTE: Code 64 12 can be caused when the +5V power line (wire 124) is shorted to ground or open. Wire 124 also provides power for the OLS, TPS, sump temperature sensor, retarder temperature sensor, and shift selectors and is present in all three ECU connectors..

1. Plug in the DDR and set to read retarder counts and percent (0 percent will be between 15 and 60 counts and 100 percent will be between 150 and 233 counts). A retarder request sensor failed high code can be caused by a short-to-battery of either signal wire 164 or power wire 124 or an open on ground wire 135. An open in the portion of the ground circuit common to the TPS and OLS devices will also result in a code 21 23 and a high fluid level reading. A retarder request sensor failed low code can be caused by an open or short-to-ground on either signal wire 164 or power wire 124.
2. Isolate and repair any wiring problems found. See Appendix E for connector service information.
3. If no wiring or connector problems are found, check the retarder request sensor voltages for each position on each of the retarder request sensors used on the vehicle. If two resistance modules are used, disconnect one of them when measuring voltage signals from the other. If problems are found, replace the resistance modules or retarder control devices.
4. If the problem persists, replace the ECU. If replacing the ECU corrects the problem, reinstall the original (bad) ECU to confirm that the problem is in the ECU. If the original ECU now works, inspect the ECU connectors for any corrosion or damage which may cause an intermittent condition. If the original problem recurs, reinstall the replacement ECU.

CODE 64 XX — RETARDER MODULATION REQUEST DEVICE FAULT

Table 6-8. RMR Device Resistance Checks

Description	Resistance Check in Resistance Module*		Voltage Signal **		Wiring to Control Device
	Terminals	Resistance ± 5%	% Retarder Application	Voltage ± 0.2 v	Device Terminal
Auto Full On	A to C	12K	100	3.6	No connections
Pressure Switch Full On High	A to C	32K	0	1.1	A
			100	3.6	B
3-Step E-10R Bendix Pedal	A to C	32K	0	1.1	A
			32	1.9	B
			58	2.8	C
			100	3.6	D
6-Step Hand Lever — Off Position 1 Position 2 Position 3 Position 4 Position 5 Position 6	A to C	32K	0	1.1	+
			14	1.5	1
			28	1.9	2
			45	2.3	3
			65	2.8	4
			82	3.2	5
			100	3.6	6
Auto ½ On	A to C	12K	50	2.4	No connections
3 Pressure Switches — Low Medium High	A to C	32K	0	1.1	A
			32	1.9	B
			68	2.8	A
			100	3.6	B
Auto ⅓ On 2 Pressure Switches Auto Medium High	A to C	21.4K	32	1.9	A
			68	2.8	B
			100	3.6	A
					B
Dedicated Pedal	No Checks	Interface not a resistance module	0	0.7 – 1.2	A
			100	3.4 – 3.5	B C

* Resistance module must be disconnected from the wiring harness and retarder control devices
 ** These voltages must be measured between terminals A and B.

CODE 65 XX — ENGINE RATING HIGH

Main code 65 indicates the vehicle's engine horsepower/governor speed rating is too high. This code is set only when computer-controlled engines are used. Code 65 means the engine computer is able to tell the transmission, the engine horsepower and/or governor speed is beyond the transmission rating or does not match the transmission shift calibration.

When a code 65 is set, no shifts out of neutral are allowed. It is possible the transmission calibration selected for this engine is improper. Contact local Allison Transmission Division distributor for assistance in selecting a proper calibration.

If the engine is beyond transmission ratings, contact the vehicle OEM for correction. The local ATD regional representative may also be contacted for assistance.

This code cannot be cleared until the proper level engine is installed or the transmission is properly calibrated.

CODE 66 XX — SCI (SERIAL COMMUNICATION INTERFACE) FAULT

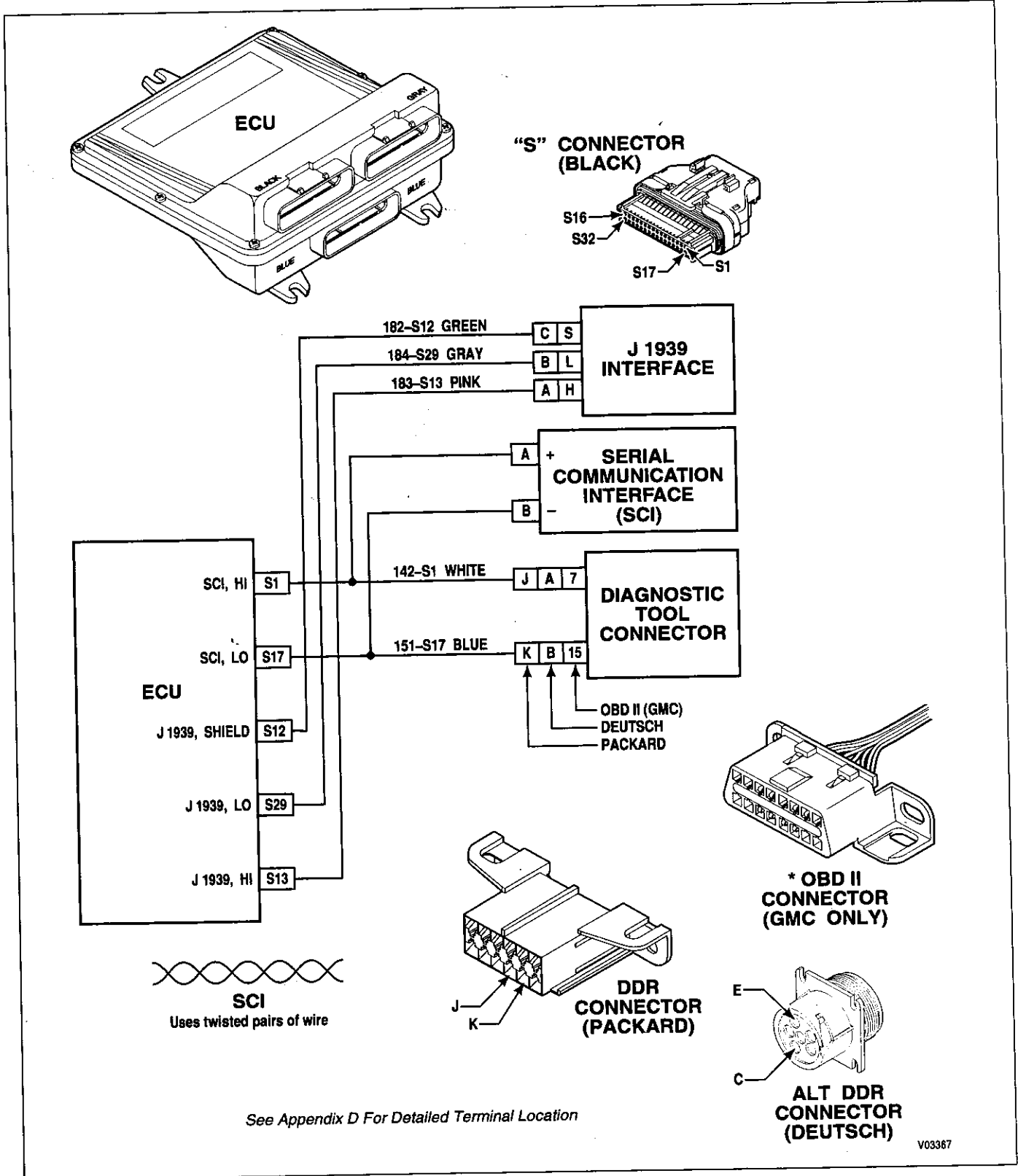

Figure 6-24. Code 66 Schematic Drawing

V03367

CODE 66 XX — SCI (SERIAL COMMUNICATION INTERFACE) FAULT (Figure 6-24)

The datalink for throttle sensor or engine coolant temperature must have been recognized by autodetect or manually selected using the Pro-Link® (see WTEC III Pro-Link® Manual) before these codes can be logged. See Paragraph 1-9 for further information.

Main code 66 indicates the ECU is expecting to get its throttle position signal or engine coolant signal across a serial communication interface from a computer-controlled engine. Either the engine computer is not sending the throttle or engine coolant information or the wiring between the engine and transmission computers has failed.

Code 66 00 can occur when the transmission ECU remains powered when the engine ECM is powered down. The transmission sees this as a communication link failure.

Main Code	Subcode	Meaning
66	00	SCI (Serial Communication Interface) fault 900 901
66	11	SCI Engine coolant source fault

A. Active Indicator Clearing Procedure:

- Power down
- Manual
- Self-clearing

B. Troubleshooting:

1. Check for a throttle signal or engine coolant signal from the engine to the transmission, an engine computer malfunction, an engine throttle fault, or an engine coolant fault.

NOTE: *Throttle position data sent from a computer-controlled engine may register a low number of counts on the DDR, but the counts will not change as throttle percentage is changed.*

2. Check wires 142 and 151 between the engine and transmission ECU for an open or short. Check that all connectors are clean and tightly connected.

NOTE: *These codes can also be set if J1939 communications fail. Check wires 183-S13, 184-S29, and 182-S12 for opens or shorts.*

3. Use the Pro-Link® to see if the ECU is receiving power when it should not.

CODE 69 XX — ECU MALFUNCTION

Main code 69 indicates a problem which has been identified as being from within the ECU.

A “cateye” display or a blank display may occur with subcode 33.

Main Code	Subcode	Meaning
69	27	ECU, Inoperative A-Hi switch
69	28	ECU, Inoperative F-Hi switch
69	29	ECU, Inoperative N-Hi and H-Hi switch
69	33	ECU, computer operating properly timeout
69	34	ECU, write timeout
69	35	ECU, checksum
69	36	ECU, RAM self-check failure
69	39	Communication chip addressing error
69	41	ECU, I/O ASIC addressing test
69	42	SPI output failure
69	43	SPI input failure

A. Active Indicator Clearing Procedure:

- Power down
- Manual — except subcodes 33, 35, 36, 41, 42, and 43
- Self-clearing — subcode 42 and subcodes 33, 35, 36, and 41; after an ECU reset

NOTE: *Subcode 34 cannot be cleared.*

B. Troubleshooting:

1. For subcodes 27, 28, and 29, check for shorts to battery before replacing the ECU. Follow the troubleshooting steps for code 42 XX for checking shorts to battery. If no shorts are found, replace the ECU. If replacing the ECU corrects the problem, reinstall the original (bad) ECU to confirm that the problem is in the ECU. If the problem recurs, reinstall the new ECU to complete the repair.
2. For all other subcodes, replace the ECU.

SECTION 7 — INPUT AND OUTPUT FUNCTIONS

7-1. INPUT FUNCTIONS

Input functions are signals sent into the ECU that prompt the ECU to take action. Input functions are activated and deactivated by switched ignition power or ground (wire 161B) to the ECU (wired through the VIW), or through the **MODE** button on the shift selector. The following input functions can be activated using the **MODE** button:

- Secondary Shift Schedule
- D1 Selection (Available With Pushbutton Selector Only)
- PTO Enable

The wiring schematic in Appendix J illustrates installation requirements for input functions and designates specific wire numbers in the transmission control system to be used for the activation of these input functions. The wiring schematic in Appendix J should be used for reference only. Ask the vehicle manufacturer which input functions are programmed, which wires are used, and whether voltage input was positive or ground. Wiring schematics for input and output functions are shown in Appendix P. The Pro-Link® 9000 can also be utilized to determine which wire was programmed for a particular input function and the wiring schematic can be consulted to find out if input to the ECU is + or - voltage. Refer to the Pro-Link® 9000 diagnostic tool operator's manual for further information regarding special input functions and other inhibits.

NOTE: *The schematic in Appendix J shows the intended use of the control features specified. These features have only been validated in the configuration shown. ANY USE OF THESE FEATURES WHICH DIFFERS FROM WHAT IS SHOWN IS NOT THE RESPONSIBILITY OF ALLISON TRANSMISSION.*

CAUTION:

Never use chassis ground as an **INPUT FUNCTION** ground. Chassis ground can carry voltage potential of 1 or 2 volts above battery ground. This non-approved input will "confuse" the ECU and cause erroneous input results. Be sure to use wire 161 which is signal ground.

Activating an input function can inhibit transmission operation in the same manner as diagnostic code. Use the Pro-Link® 9000 to verify an active input function or a diagnostic code inhibit. Refer to the Pro-Link® 9000 Diagnostic Tool Operator's Manual for further information regarding special input functions and other inhibits. Also, for more detailed information on input functions, refer to the Sales Tech Data Book "WTEC III Controls and General Information."

The maximum number of input and output functions which may be used in any installation depends upon the transmission model and its features. Refer to Table 7-1.

Table 7-1. Input/Output Function Availability

Transmission Model	Auxiliary Transmission Controls Functions	Number Of Input Functions	Number Of Output Functions
6-Speed Models	Retarder	10 + Mode Button	6
7-Speed Models	Transfer Case	11 + Mode Button	6

INPUT AND OUTPUT FUNCTIONS

The following input functions inhibit direction change shifts (forward to reverse or reverse to forward):

- Auxiliary Function Range Inhibit (standard)
- Auxiliary Function Range Inhibit (special)
- Quick to Neutral, Pump Option
- Automatic Neutral for PTO
- Automatic Neutral at Stop
- Reverse Enable
- Automatic Neutral for Refuse Packers
- Automatic Neutral for Refuse Packers with Service Brake Input

The following input functions lock the transmission in fourth range:

- Fire Truck Pump Mode
- Fourth Lockup Pump Mode

The following input functions preselect a lower range:

- Engine Brake and Preselect Request (standard)
- Engine Brake and Preselect Request (special)

The following input functions inhibit upshifts:

- D1 Selection
- Auxiliary Hold

The following input functions inhibit lockup shifts:

- Manual Lockup
- Anti-lock Brake Response

The following input function inhibits range and lockup shifts at high horsepower:

- Shift Enable/Shift in Process (Oil Field Application)

The following functions are general restrictions to normal operation:

- High Input Speed causes neutral to range inhibit
- Medium Cold Oil causes operation confined to **R** (Reverse), **N** (Neutral), and 2nd range start
- Hot Oil restricts operation to 4th range maximum (except emergency applications)
- Two Speed Axle Enable permits change only at low output speed and throttle
- Special Pattern Logic monitors **N** or **D** or **N** to **R** shifts. If engine throttle or output speed is too high, the transmission remains in **N**.
- Wheel Lock disengages the lockup clutch and inhibits forward range downshifts and shifts to reverse
- Anti-lock Brake Response deactivates the retarder and disengages the lockup clutch
- High Throttle during **N** (Neutral) to any range shift causes a revised clutch pressure apply rate and turns off shift adaptive
- Power loss to the ECU restricts operation to certain ranges (for exact range see code 13 XX in Section 6)

The following input function limits operation to 1st Range and **N** (Neutral):

- Refuse Vehicle Step Switch

INPUT AND OUTPUT FUNCTIONS

7-2. OUTPUT FUNCTIONS

Output functions are signals sent out by the ECU that activate or control devices or mechanisms. These control devices or mechanisms are controlled by relays or direct connection signals from the ECU.

Many input and output functions are closely related. For instance, the PTO Enable option (input function) also includes PTO Output wiring information. When searching for output function information, be sure to check any related input function information references.

The wiring schematics in Appendix J and Appendix P illustrate installation requirements for output functions as well as input functions and designate specific wire numbers in the transmission control system to be used for the activation of these output functions. The wiring schematics in Appendix J should be used for reference only. Ask the vehicle manufacturer which specific output functions are programmed and which wires are used. Output function polarity is not significant when an Allison-supplied VIM is used. The Pro-Link® 9000 can also be utilized to determine which wire was programmed for a particular output function. For more detailed information on output functions, refer to the Sales Tech Data Book "WTEC III Controls and General Information" (the schematics in Appendix P are from the Sales Tech Data Book).

INPUT AND OUTPUT FUNCTIONS

NOTES

SECTION 8 — GENERAL TROUBLESHOOTING OF PERFORMANCE COMPLAINTS

IMPORTANT:

Make the following general checks before beginning specific troubleshooting, removing the transmission, or removing attached components.

- Are there active diagnostic codes?
- Is the lever shift selector lever in **N** (Neutral) to allow starting the engine?
- Is the battery properly connected and charged?
- Is isolated battery properly connected (if used)?
- Have the items on Pages 6–15 and 6–16 in Paragraph 6–5 been checked?
- Is the fluid level correct?
- Is voltage to the ECU correct?
- Is the engine properly tuned?
- Is fuel flow to the engine correct?
- Are wheel chocks in place?
- Is air flow to the cooler and radiator unrestricted?
- Is the driveline properly connected?
- Are there signs of fluid leakage under the vehicle? What is the origination point?
- Are hydraulic connections correctly made and not leaking?
- Is vehicle acceleration from a stop changed?
- Are electrical connections correctly made?
- Are there any other obvious vehicle or transmission problems?

After making these general checks use the various sections of this manual to isolate the listed problems. The following charts address specific vehicle complaints. Some complaints involve diagnostic codes, so all troubleshooting checks should involve checking the system for diagnostic codes.

GENERAL TROUBLESHOOTING OF PERFORMANCE COMPLAINTS

Table 8-1. Troubleshooting Performance Complaints

Problem	Probable Cause	Suggested Remedy
SHIFT SELECTOR DISPLAYS "CATEYE" AND VEHICLE IS NOT OPERABLE	No communication between the ECU and a remote shift selector	Refer to code 23 XX in Troubleshooting Procedure
SHIFT SELECTOR DISPLAY IS BLANK	VIM Fuse is blown	Replace VIM fuse
	Fuse blown in OEM substitute	Replace fuse for VIM
	Failed SDL (Serial Data Link)	Should change to "cateye" within 12 seconds (see Code 23 16)
VEHICLE WILL NOT START (ENGINE WILL NOT CRANK)	Lever shift selector not in neutral	Select N (Neutral) and restart
	Dead battery	Recharge battery
	Disconnected battery	Reconnect battery
	Faulty starter circuit	Repair vehicle starter circuit
	Faulty neutral start relay	Replace neutral start relay
	Faulty wiring in neutral start circuit	Repair wiring
	Voltage to ECU too low	Check battery and charging system voltage
	Faulty ignition wire (146)	Repair wire 146
	Faulty lever shift selector	Replace lever shift selector
	Lack of battery voltage on Circuit 123 from ECU when in neutral	Repair Circuit 123 or replace ECU
All display segments of display lighted	No calibration installed in ECU	Load Calibration
	Voltage to ECU too low	Check battery and charging system voltage
CHECK TRANS LIGHT WILL NOT GO OUT AT START-UP		
A. Vehicle Drives Normally	Faulty CHECK TRANS light, relay, or circuit.	Replace relay or repair circuit
	An LED rather than a lamp is installed for the CHECK TRANS light and the LED is partially lighted from leakage current	Install a lamp rather than an LED for the CHECK TRANS light
B. Vehicle Does Not Drive	Faulty ECU	Replace the ECU
	Engine does not start	Repair engine starting system
	Faulty harness	Repair harness (See Section 4 and Appendix E)

GENERAL TROUBLESHOOTING OF PERFORMANCE COMPLAINTS

Table 8-1. Troubleshooting Performance Complaints (cont'd)

Problem	Probable Cause	Suggested Remedy
B. Vehicle Does Not Drive (cont'd)	Faulty interface wiring to vehicle electrical system	Repair wiring (See Appendix E)
	Faulty ECU	Replace the ECU
CHECK TRANS LIGHT FLASHES INTERMITTENTLY	Intermittent power to ECU	Check input power to the ECU and correct if necessary
	Loose wiring to CHECK TRANS light	Repair wiring
	Faulty or incorrect ground wire attachment	Repair ground circuit
	Intermittent opening in Circuit 115	Repair Circuit 115
NO CHECK TRANS LIGHT AT IGNITION	Faulty light bulb or socket	Replace light bulb or socket
	Incorrect wiring to and from CHECK TRANS light bulb	Repair wiring (See Appendix E)
	Faulty wiring harness	Check wiring between ECU and CHECK TRANS light, and repair where necessary (See Appendix E)
	Circuit 115 open	Repair Circuit 115
	Faulty ECU	Replace ECU
ECU WILL NOT TURN OFF WHEN IGNITION SWITCH OFF	Faulty ignition switch	Replace ignition switch
	Externally-generated speed sensor signal(s) (refer to Appendix L for detailed inspection)	Find source of false speed sensor signal(s) and correct problem
TRANSMISSION WILL NOT SHIFT TO FORWARD OR REVERSE (STAYS IN NEUTRAL)	Engine rpm too high	Reduce engine rpm (it may be necessary to reselect Neutral also, and then D or R)
	Low fluid level	Add fluid to proper level (refer to transmission Mechanic's Tips for proper dipstick calibration)
	Throttle position sensor or linkage is not functioning properly	Refer to throttle position sensor for correct set-up (Appendix F)
	Voltage to ECU too low	Check vehicle battery and charging system

GENERAL TROUBLESHOOTING OF PERFORMANCE COMPLAINTS

Table 8-1. Troubleshooting Performance Complaints (cont'd)

Problem	Probable Cause	Suggested Remedy
TRANSMISSION WILL NOT SHIFT TO FORWARD OR REVERSE (STAYS IN NEUTRAL) (cont'd)	Shift selector is not functioning properly	Replace shift selector
	Disconnected or dirty connectors	Perform connector checkout (Appendix E)
	Faulty wiring harnesses	Repair harness (Appendix E)
	Speed sensor(s) not functioning properly	Repair or replace speed sensor(s) or circuitry (see transmission Service Manual and Appendix E)
	Faulty ECU	Replace the ECU
	Input function wire open and auxiliary function range inhibit in the calibration	Check input function programming with Pro-Link®. Correct wiring or switch problem which does not allow input function wire to be grounded.
TRANSMISSION WILL NOT STAY IN FORWARD OR REVERSE	Auxiliary Function Range Inhibit-Standard — hooked up to brake pressure	Apply brakes with high force
	Auto-neutral or quick-to-neutral circuit (input function) faulty	Repair quick-to-neutral circuit
	Leaking at solenoid assembly	Rebuild solenoid assembly (see transmission Service Manual)
TRANSMISSION WILL NOT MAKE A SPECIFIC SHIFT	Faulty solenoid — leaking	Replace solenoid (see transmission Service Manual)
	Low engine power	Correct engine problem, see Engine Service Manual
	Incorrect fluid level	Correct fluid level (refer to transmission Mechanic's Tips for proper dipstick calibration)
	Extreme fluid temperature	Inspect cooling system and fluid level
	Faulty speed sensor/circuit	Repair circuit or replace speed sensor(s) (see code 22 XX)
	Faulty temperature sensor/circuit	Check for temperature reading which inhibits shifts
	Incorrect calibration	Install proper calibration

GENERAL TROUBLESHOOTING OF PERFORMANCE COMPLAINTS

Table 8-1. Troubleshooting Performance Complaints (cont'd)

Problem	Probable Cause	Suggested Remedy
TRANSMISSION WILL NOT MAKE A SPECIFIC SHIFT <i>(cont'd)</i>	Faulty shift selector	Replace shift selector
	Hydraulic problem	Refer to Range Clutch Troubleshooting section
	Faulty ECU	Replace ECU
TRANSMISSION DOES NOT SHIFT PROPERLY (ROUGH SHIFTS, SHIFTS OCCURRING AT TOO LOW OR TOO HIGH SPEED)	Engine idle speed too fast (neutral to range shift)	Adjust engine idle speed (refer to Vehicle Service Manual)
	Faulty throttle sensor/circuit	Refer to throttle sensor section for installation and operation information (Appendix F)
	ECU input voltage low	Check power, ground, charging system, and battery function
	Incorrect shift calibration for vehicle	Install correct calibration
	Instrument panel tachometer incorrect	Repair or replace tachometer
	Incorrectly calibrated electronic speedometer	Calibrate electronic speedometer
	Faulty speed sensor/circuit	Repair circuit or replace speed sensor (see code 22 XX)
	Loose speed sensor	Tighten speed sensor retaining bracket bolt
	Incorrect fluid level	Correct fluid level (refer to Mechanic's Tips for proper dipstick calibration)
	Crossed wires in harness	Check for crossed wires and correct
	Intermittent problems	Check wiring harnesses and connectors (Appendix E)
	Loose or damaged speed gear	Replace output bearing nut sensor retainer
	Control spool valve sticking	Overhaul valve body assembly (refer to transmission Service Manual)
Sticking stage 2 solenoid valve	Overhaul valve body assembly (refer to transmission Service Manual)	
Incorrect calibration	Install correct calibration	

GENERAL TROUBLESHOOTING OF PERFORMANCE COMPLAINTS

Table 8-1. Troubleshooting Performance Complaints (cont'd)

Problem	Probable Cause	Suggested Remedy
RETARDER PERFORMANCE COMPLAINTS		
A. Retarder Does Not Apply	Retarder enable input not activated	Turn on retarder enable switch (if present).
	Retarder enable switch not working	Replace retarder enable switch (if present).
	ABS input is active (if vehicle is equipped with ABS)	None — This is normal. If ABS is active, retarder will not apply.
	Retarder Request below 10.2 percent	Use DDR to determine counts signaled by each RMR device present. At least 15 counts are required for some retarder apply and 150–232 counts are required for full apply. Replace RMR device, based on test results.
	Closed throttle not sensed	Use DDR to check throttle signal. Throttle must be below 9.8 percent before retarder will apply. Readjust or replace TPS. Exception: If TPS has failed and Service Brake Status input is sensed by ECU, the retarder will still be applied.
	Active code inhibiting retarder	Correct cause for setting these codes: 42 23, 44 23, 45 23, 46 26, 64 12, 64 23, or 69 29
	Transmission output speed below 350 rpm (450 rpm for HD/B 500)	Raise output speed to above 350 rpm (450 rpm for HD/B 500)
B. Reduced Retarder Effect	Transmission not in a forward range	Shift to a forward range
	Retarder accumulator solenoid not being energized	Correct cause for setting these codes: 42 26, 44 26, 45 26, or 69 26.
	ECU sensing false overheat condition	Use DDR or VOM to check retarder temperature sensor. Replace sensor as required.
C. Less Retarder Effect Than Expected	Normal response to overheating	See Table 6-7 in Section 6 (Code 61)
	Transmission fluid aerated due to incorrect level	Check transmission fluid level and correct as required.

GENERAL TROUBLESHOOTING OF PERFORMANCE COMPLAINTS

Table 8-1. Troubleshooting Performance Complaints (cont'd)

Problem	Probable Cause	Suggested Remedy
C. Less Retarder Effect Than Expected (<i>cont'd</i>)	Wrong retarder control regulator valve spring	Check retarder charging pressure. Change retarder control valve regulator spring, if necessary. See SA2831 WT Series Retarder Principles of Operation.
ABNORMAL ACTIVITIES OR RESPONSES		
A. Excessive Creep in First and Reverse Gears	Engine idle speed too high	Adjust to correct idle speed — between 500–800 rpm (refer to Vehicle Service Manual)
B. No Response to Shift Selector	Shift selector not properly connected	Check shift selector response with diagnostic tool. If no response, check remote connection and replace if necessary
	Using wrong selector on dual station equipment	Use other selector
	Faulty shift selector	Replace shift selector
	Incorrect fluid level	Correct fluid level (refer to transmission Mechanic's Tips for proper dipstick calibration)
	Main pressure low	Refer to Low Pressure section
C. Vehicle Moves Forward in Neutral*	Control spool valves sticking (C1, C3, or C5 clutch pressure low)	Overhaul valve body assembly (refer to transmission Service Manual)
	C1 clutch failed or not released	Rebuild C1 clutch (refer to transmission Service Manual)
D. Vehicle Moves Backward in Neutral*	C3 clutch failed or not released	Rebuild C3 clutch assembly (refer to transmission Service Manual)
EXCESSIVE FLARE — ENGINE OVERSPEED ON FULL-THROTTLE UPSHIFTS	TPS Adjustment:	
	— Overstroke	— Adjust TPS linkage for proper stroke (see Appendix F)
	— Loose	— Tighten loose bolts or connections
	Incorrect calibration	Correct calibration

* See explanation of NVL in Section 2-3.

GENERAL TROUBLESHOOTING OF PERFORMANCE COMPLAINTS

Table 8-1. Troubleshooting Performance Complaints (cont'd)

Problem	Probable Cause	Suggested Remedy
EXCESSIVE FLARE — ENGINE OVERSPEED ON FULL-THROTTLE UPSHIFTS <i>(cont'd)</i>	ECU input voltage low	Check electrical system and all connections from battery and ECU
	Incorrect fluid level	Add fluid to proper level (refer to transmission Mechanic's Tips for proper dipstick calibration)
	Low main pressure	See Low Pressure section
	Erratic speed sensor signal	See code 22 XX
	Sticking stage 2 solenoid valve (see Solenoid and Clutch sections)	Clean and repair stage 2 valve (refer to transmission Service Manual)
	Piston seals leaking or clutch plates slipping in range involved (see Range Clutch Troubleshooting section)	Overhaul transmission (refer to transmission Service Manual)

RANGE CLUTCH TROUBLESHOOTING SECTION

EXCESSIVE SLIPPAGE AND CLUTCH CHATTER	Incorrect calibration	Verify calibration
	ECU input voltage low	Check power, ground, charging system, and battery functions
	Throttle position sensor out of adjustment or failed	Adjust or replace throttle position sensor (refer to Appendix F)
	Incorrect speed sensor readings	See code 22 XX
	Incorrect fluid level	Correct fluid level (refer to Mechanic's Tips for proper dipstick calibration measurements)
	Main pressure low	Refer to the Low Pressure section
	Lockup clutch not applied	Inspect lockup clutch system wiring, pressure, and controls; repair as necessary (refer to transmission Service Manual)*
A. Ranges 1, 2, 3, 4 Only (6-Speed) Ranges 2, 3, 4, 5 only (7-Speed)	C1 clutch slipping, leaks at splitline gasket, leaks at rotating clutch seals, leaks at piston seals, C1 clutch plates worn	Inspect control module gasket, C1 clutch plates, and piston and rotating seals; replace/rebuild as necessary (refer to transmission Service Manual)*

* See Appendix B — Check main pressure, clutch pressure, and pressure specifications.

GENERAL TROUBLESHOOTING OF PERFORMANCE COMPLAINTS

Table 8-1. Troubleshooting Performance Complaints (cont'd)

Problem	Probable Cause	Suggested Remedy
EXCESSIVE SLIPPAGE AND CLUTCH CHATTER (cont'd)		
B. Ranges 4, 5, 6 Only (6-Speed) Ranges 5, 6, 7 only (7-Speed)	C2 clutch slipping, leaks at splitline gasket, leaks at rotating clutch seals, leaks at piston seals, C2 clutch plates worn	Inspect control module gasket, C2 clutch plates, and piston and rotating seals; replace/rebuild as necessary (refer to transmission Service Manual)*
C. Ranges 3, 5, R Only (6-Speed) Ranges 1, 4, 6, R only (7-Speed)	C3 clutch slipping, leaks at face seals, leaks at piston seals, C3 clutch plates worn	Inspect control module face seals, C3 clutch plates, and piston seals; replace/rebuild as necessary (refer to transmission Service Manual)*
D. Ranges 2, 6 Only (6-Speed) Ranges 3, 7 only (7-Speed)	C4 clutch slipping, leaks at face seals, leaks at piston seals, C4 clutch plates worn	Inspect control module face seals, C4 clutch plates, and piston seals; replace/rebuild as necessary (refer to transmission Service Manual)*
E. Ranges 1, R Only (6-Speed) Ranges 2, R only (7-Speed)	C5 clutch slipping, leaks at face seals, leaks at piston seals, C5 clutch plates worn	Inspect control module face seals, C5 clutch plates, and piston seals; replace/rebuild as necessary (refer to transmission Service Manual)*
F. Range Lo Only (7-Speed)	C6 clutch slipping, leaks at splitline gasket(s), leaks at piston seals, C6 clutch plates worn	Inspect control module gasket, adapter gasket, T-Case gasket(s) C6 clutch plates, and piston seals; replace/rebuild as necessary (refer to transmission Service Manual)*
LOW PRESSURE SECTION		
A. Low Main Pressure in All Ranges (Including C6, T-Case)	Incorrect fluid level	Correct fluid level (refer to the Mechanic's Tips Handbook for correct dipstick calibration)*
	Oil filter element clogged or faulty	Replace oil filter (refer to transmission Mechanic's Tips)
	Plugged or faulty suction filter	Clean or replace oil suction filter element and refill the transmission (refer to transmission Mechanic's Tips)
	Main pressure regulator valve sticking	Overhaul control module assembly (refer to transmission Service Manual)

* See Appendix B — Check main pressure, clutch pressure, and pressure specifications.

GENERAL TROUBLESHOOTING OF PERFORMANCE COMPLAINTS

Table 8-1. Troubleshooting Performance Complaints (cont'd)

Problem	Probable Cause	Suggested Remedy
A. Low Main Pressure in All Ranges (Including C6, T-Case) (cont'd)	Main pressure regulator valve spring weak, broken, or missing	Check spring and replace if necessary (refer to transmission Service Manual)
	Control module body leakage (separator plate not flat, separator plate gasket leakage, loose control valve body bolts)	Replace or rebuild control module assembly. Care should be taken when removing and labeling shift springs (refer to transmission Service Manual)
	Faulty or incorrect fluid pressure gauge	Repair or replace gauge
	Oil pump worn or damaged	Replace or rebuild oil pump (refer to transmission Service Manual)
B. Clutch Pressure Low in Specific Ranges, Normal Pressure in Other Ranges		See Range Clutch Troubleshooting section and Appendix B
C. Low Lubrication Pressure	Incorrect fluid level	Correct fluid level (refer to the Mechanic's Tips Handbook for proper dipstick calibration)
	Plugged lube filter	Change filter (refer to Transmission Mechanic's Tips)
	Excessive internal fluid leakage	Check other pressures (above items); also check control module mounting bolts; lubrication valve and spring (refer to transmission Service Manual)
	Broken or damaged converter regulator retaining pin	Replace damaged or broken parts (refer to transmission Service Manual)
	Cooler lines restricted or leaking	Check for kinks, leakage; reroute or replace lines as necessary
	Lubrication valve sticking	Replace lubrication valve
	Cooler plugged	Clean or replace cooler
	Faulty gauge	Repair or replace gauge

GENERAL TROUBLESHOOTING OF PERFORMANCE COMPLAINTS

Table 8-1. Troubleshooting Performance Complaints (cont'd)

Problem	Probable Cause	Suggested Remedy
ABNORMAL STALL SPEEDS (Stall In First Range — 6-Speed) (Stall In Second Range — 7-Speed)		
A. High Stall Speeds	Not in gear	Select D (Drive)
	Low fluid level, aerated fluid	Add fluid to proper level (refer to Mechanic's Tips for proper dipstick calibration)
	Incorrect torque converter	Replace torque converter (refer to transmission Service Manual)
	Clutch pressure low	Refer to Low Pressure section and Appendix B
	C1 or C5 clutch slipping. (7-speed, 2nd gear start) (6-speed, 1st gear start) <i>Note:</i> Use the diagnostic tool to check turbine speed	Rebuild C1 or C5 clutch (refer to transmission Service Manual)
	Higher power engine	Confirm proper engine match
B. Low Stall Speeds	Engine not performing efficiently (may be due to plugged or restricted injectors, high altitude conditions, dirty air filters, out of time, throttle linkage, electronic engine controls problem)	Refer to Vehicle Engine Manufacturer's Manual or Vehicle Service Manual
	Stall speeds of 66 percent of normal implies freewheeling stator	Replace or rebuild converter assembly (refer to transmission Service Manual)
	Incorrect torque converter	Install correct torque converter (refer to transmission Service Manual)
OVERHEATING IN ALL RANGES		
	Aerated fluid — incorrect fluid level	Adjust fluid to proper level, check for defective pump (refer to Mechanic's Tips and transmission Service Manual)
	Air flow to cooler obstructed	Remove air flow obstruction
	Engine overheat	Correct overheat situation (refer to Vehicle Service Manual)
	Inaccurate temperature gauge or sending unit	Replace gauge and/or sending unit

GENERAL TROUBLESHOOTING OF PERFORMANCE COMPLAINTS

Table 8-1. Troubleshooting Performance Complaints (*cont'd*)

Problem	Probable Cause	Suggested Remedy
OVERHEATING IN ALL RANGES (<i>cont'd</i>)	Inaccurate sump temperature sensor	Replace temperature sensor or internal harness (refer to transmission Service Manual)
	Transmission cooler lines reversed	Connect cooler lines properly (oil and water should flow in opposite directions)
	Fluid cooler lines restricted	Remove restrictions, clean or replace lines (refer to Vehicle Service Manual)
	Torque converter (wrong converter, no lockup, stuck stator, or slipping stator)	Replace or repair converter assembly. (refer to transmission Service Manual) <i>Note:</i> Stuck stator will not allow cool down in neutral
	Cooler flow loss due to internal leakage	Overhaul transmission (refer to transmission Service Manual)
	Inadequate cooler sizing	See vehicle OEM for specifications
	Excessive cooler circuit pressure drop	Check for plugged cooler, lines too small, collapsed hose, too many elbows in circuit
FLUID COMES OUT OF THE FLUID FILL TUBE AND/OR BREATHER	Dipstick loose	Tighten cap, replace if necessary
	Fluid level too high	Drain to proper level (refer to transmission Mechanic's Tips)
	Fluid level too low	Add fluid to proper level
	Breather stopped up — clogged	Clean or replace breather (refer to transmission Service Manual)
	Fluid contaminated with foreign liquid	Drain and replace fluid. Locate and fix source of additional fluid (refer to transmission Service Manual if repair is needed)
	Dipstick or fill tube seal worn	Replace seals or dipstick
	Incorrect dipstick marking	Calibrate dipstick (refer to transmission Mechanic's Tips)
NOISE OCCURRING INTERMITTENTLY (BUZZING)	Low fluid level	Add fluid to proper level (refer to transmission Mechanic's Tips for proper dipstick calibration)

GENERAL TROUBLESHOOTING OF PERFORMANCE COMPLAINTS

Table 8-1. Troubleshooting Performance Complaints (cont'd)

Problem	Probable Cause	Suggested Remedy
NOISE OCCURRING INTERMITTENTLY (BUZZING) (cont'd)	Air leak in oil suction screen canister	Replace oil suction screen canister (refer to transmission Service Manual)
	Clogged filters	Replace filters (refer to transmission Mechanic's Tips)
	Aerated fluid causes noisy pump	Correct fluid level (refer to transmission Mechanic's Tips for proper dipstick calibration)
	Low main pressure causes main regulator valve to oscillate	See Low Pressure section
LEAKING FLUID (OUTPUT SHAFT)	Faulty or missing seal at output flange	Install new lip-type seal in rear of transmission housing (refer to transmission Service Manual)
	Machine lead on output flange seal surface	Replace flange
	Flange worn at seal surface	Replace flange
	Insufficient seal around seal OD	When replacing seal, apply sealant (refer to transmission Service Manual)
	Damaged, missing, or loose output flange bolts	Replace and/or torque output flange bolts
	Damaged or missing flange button O-ring	Replace flange button O-ring
	Damaged or missing bolt O-rings	Replace O-rings
TRANSMISSION INPUT	Front seal leaks	Replace front seal (refer to transmission Service Manual)
	Converter leaks	Check converter seals, cracked converter pump tangs, converter cover, or converter housing porosity; replace parts as required (refer to transmission Service Manual)
	PTO driveline out of specification	Bring driveline into specification
DIRTY FLUID	Failure to change fluid and filters	Change fluid and install new filters (refer to transmission Mechanic's Tips)

GENERAL TROUBLESHOOTING OF PERFORMANCE COMPLAINTS

Table 8-1. Troubleshooting Performance Complaints (cont'd)

Problem	Probable Cause	Suggested Remedy
DIRTY FLUID (cont'd)	Excessive heat	Refer to Overheating section
	Damaged fluid filter/seals	Replace oil filter/seals (refer to transmission Mechanic's Tips)
	Substandard fluid	Use recommended fluid (refer to transmission Mechanic's Tips)
	Clutch/transmission failure	Overhaul transmission (refer to transmission Service Manual)
POWER TAKEOFF (PTO)*		
A. Leaks	Damaged or cocked seal	Replace seal
	PTO flange grooved at seal	Replace PTO flange
	Loose flange	Inspect flange and bolts; replace if necessary and properly torque bolts
	Loose bolts or damaged gaskets	Replace gasket and/or properly torque bolts
	Loose or damaged hydraulic lines (clutched drive)	Tighten fittings (replace if necessary)
B. Noisy PTO	Faulty driven component	Replace faulty driven component
	Gears or bearings worn, damaged, or contaminated	Rebuild PTO with new gears or bearings
C. No or Intermittent Operation (Clutched Drive)	Electrical problem (switch, connectors, solenoid, or wires)	Inspect for electrical problem and repair (see Appendix E)
	Damaged or worn clutch	Rebuild clutch assembly
C. No or Intermittent Operation (Clutched Drive) (cont'd)	Clutch piston seals damaged or missing	Rebuild clutch assembly
	Inadequate fluid pressure to PTO	Inspect and repair fluid pressure supply; line kinked, loose, or plugged; orifice too small
	Engine speed outside operating band	Increase or reduce engine speed to move within operating band
	Drive or driven gear teeth damaged	Replace damaged gears (refer to transmission Service Manual)

* Contact your nearest Allison dealer/distributor with specific questions relating to PTO repair.

GENERAL TROUBLESHOOTING OF PERFORMANCE COMPLAINTS

Table 8-1. Troubleshooting Performance Complaints (cont'd)

Problem	Probable Cause	Suggested Remedy
TRANSFER CASE (T-CASE)		
A. Will Not Go Into First Range	TPS adjustment	Properly adjust TPS (refer to Appendix F)
	Engine speed too high	Reduce Engine Speed
	Wrong calibration	Calibrate properly
	Wrong control module (6 speed instead of 7 speed)	Install correct control module
	Faulty wiring, solenoid connectors	Check wiring and connectors in control module (refer to transmission Service Manual)
	Faulty C6 seals	Replace C6 piston seals (refer to transmission Service Manual)
	Worn C6 clutch plates	Rebuild C6 (refer to transmission Service Manual)
B. Makes Excessive Noise	Improperly shimmed bearings	Check all T-case bearings as directed in transmission repair manual. Reshim as necessary.
C. No Front Output Drive	Differential clutch bad (C7 piston seals, C7 rotating seals, C7 clutch plates, C7 check ball)	Rebuild differential clutch (refer to transmission Service Manual)
	C7 electrical (wires, solenoids, terminals, connectors)	Inspect and repair C7 electrical system (refer to Appendix E)
D. Transmission Fluid Leaks	Damaged output seal, output flange seal journal, gasketed mating surfaces, bearing endcaps, electrical connector, oil scavenge line	Determine source of leak and repair (refer to transmission Service Manual)

GENERAL TROUBLESHOOTING OF PERFORMANCE COMPLAINTS

Table 8-2. Resistance Module Troubleshooting Data

Description	Resistance Check in Resistance Module*		Voltage Signal**		Wiring to Control Device
	Terminals	Resistance — Ohms ± 5%	% Retarder Application	Voltage ± 0.2V	Device Terminal
Auto Full On	A to C	12K	100	3.6	No connections
Pressure Switch Full On High	A to C	32K	0 100	1.1 3.6	A B
3-Step E-10R Bendix Pedal	A to C	32K	0 32 58 100	1.1 1.9 2.8 3.6	A B C D
6-Step Hand Lever — Off Position 1 Position 2 Position 3 Position 4 Position 5 Position 6	A to C	32K	0 16 28 48 65 84 100	1.1 1.5 1.9 2.3 2.8 3.2 3.6	+ 1 2 3 4 5 6
Auto 1/2 On	A to C	12K	50	2.4	No connections
3 Pressure Switches — Low Medium High	A to C	32K	0 32 68 100	1.1 1.9 2.3 3.6	A B A B A B
Auto 1/3 On 2 Pressure Switches Auto Medium High	A to C	21.4K	 32 68 100	 1.9 2.8 3.6	 A B A B
Dedicated Pedal	No Checks	Interface not a resistance module	0 100	0.7-1.2 3.4-3.5	A B C

* Resistance module must be disconnected from the wiring harness and retarder control devices.

** These voltages must be measured between terminals A and B.

APPENDICES

Appendix A	Identification of Potential Circuit Problems
Appendix B	Checking Clutch Pressures
Appendix C	Solenoid and Clutch Chart
Appendix D	Wire/Connector Chart
Appendix E	Connector Part Numbers, Terminal Part Numbers, Tool Part Numbers, and Repair Instructions
Appendix F	Throttle Position Sensor Adjustment
Appendix G	Welding on Vehicle/Vehicle Interface Module
Appendix H	Hydraulic Schematics
Appendix J	WT Wiring Schematic
Appendix K	TransID 1 Temperature Sensor and Solenoid Resistance Charts
Appendix L	Externally-Generated Electronic Interference
Appendix M	Diagnostic Tree — WT Series Hydraulic System
Appendix N	Pro-Link® 9000 Diagnostic Data Reader Information
Appendix P	Input/Output Function Wiring Schematics
Appendix Q	TransID 2 Thermistor Troubleshooting Information

APPENDIX A — IDENTIFICATION OF POTENTIAL CIRCUIT PROBLEMS

Intermittent codes are a result of faults that are detected, logged, and then disappear, only to recur later. If, when troubleshooting, a code is cleared in anticipation of it recurring and it does not, check the items in the following list for the fault's source.

A. Circuit Inspection

1. Intermittent power/ground problems — can cause voltage problems during ECU diagnostic checks which can set various codes depending upon where the ECU was in the diagnostic process.
2. Damaged terminals.
3. Dirty or corroded terminals.
4. Terminals not fully seated in the connector. Check indicated wires by uncoupling connector and gently pulling on the wire at the rear of the connector and checking for excessive terminal movement.
5. Connectors not fully mated. Check for missing or damaged locktabs.
6. Screws or other sharp pointed objects pushed into or through one of the harnesses.
7. Harnesses which have rubbed through and may be allowing intermittent electrical contact between two wires or between wires and vehicle frame members.
8. Broken wires within the braiding and insulation.

B. Finding an Intermittent Fault Condition

To find a fault, like one of those listed, examine all connectors and the external wiring harnesses. Harness routing may make it difficult to see or feel the complete harness. However, it is important to thoroughly check each harness for chafed or damaged areas. Road vibrations and bumps can damage a poorly installed harness by moving it against sharp edges and cause some of the faults. If a visual inspection does not identify a cause, move and wiggle the harness by hand until the fault is duplicated.

The next most probable cause of an intermittent code is an electronic part exposed to excessive vibration, heat, or moisture. Examples of this are:

1. Exposed harness wires subjected to moisture.
2. A defective connector seal allows moisture to enter the connector or part.
3. An electronic part (ECU, shift selector, solenoid, or throttle sensor) affected by vibration, heat, or moisture may cause abnormal electrical conditions within the part.

When troubleshooting Item 3, eliminate all other possible causes before replacing any parts.

Another cause of intermittent codes is good parts in an abnormal environment. The abnormal environment will usually include excessive heat, moisture, or voltage. For example, an ECU that receives excessive voltage will generate a diagnostic code as it senses high voltage in a circuit. The code may not be repeated consistently because different circuits may have this condition on each check. The last step in finding an intermittent code is to observe if the code is set during sudden changes in the operating environment.

Troubleshooting an intermittent code requires looking for common conditions that are present whenever the code is diagnosed.

APPENDIX A — IDENTIFICATION OF POTENTIAL CIRCUIT PROBLEMS

C. Recurring Conditions

A recurring condition might be:

- Rain
- Outside temperature above or below a certain temperature
- Only on right-hand or left-hand turns
- When the vehicle hits a bump, etc.

If such a condition can be related to the code, it is easier to find the cause. If the time between code occurrences is very short, troubleshooting is easier than if it is several weeks or more between code occurrences.

APPENDICES

NOTES

APPENDIX B — CHECKING CLUTCH PRESSURES

Checking individual clutch pressures helps to determine if a transmission malfunction is due to a mechanical or an electrical problem. Properly making these pressure checks requires transmission and vehicle (or test stand) preparation, recording of data, and comparing recorded data against specifications provided. These instructions are for all WT Series transmissions.

NOTE: Check to see if there are diagnostic codes set which are related to the transmission difficulty you are evaluating. Proceed to make mechanical preparations for checking clutch pressures after codes have first been evaluated.

A. Transmission and Vehicle Preparation

1. Remove the plugs from the pressure tap locations where measurement is desired (refer to Figure B-1).

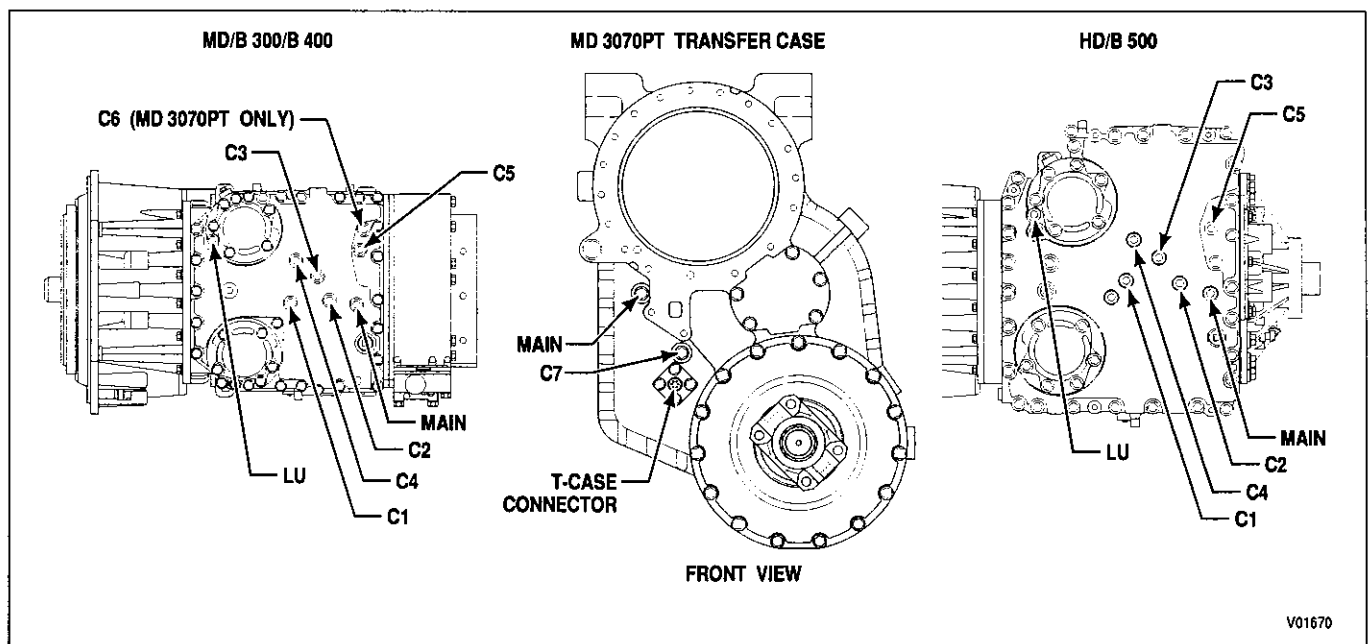

Figure B-1. Clutch Pressure Check Points

CAUTION: Be sure that the hydraulic fittings have the same thread as the plugs removed (7/16-20 UNF-2A). Also please note that these fittings must be straight thread, O-ring style. Failure to do this will result in damage to the control module.

2. Install hydraulic fittings suitable for attaching pressure gauges or transducers.
3. Connect pressure gauges or transducers. Pressure gauge set J 26417-A is available for this purpose. See Table B-2 for pressure levels expected.
4. Check that engine speed can be monitored (Pro-Link® 9000 diagnostic tool may be used for this purpose).
5. Be sure that transmission sump fluid temperature can be measured (Pro-Link® 9000 diagnostic tool may be used for this purpose).
6. Be sure that the transmission has enough fluid for cold operation until an operating temperature fluid level can be set.

APPENDIX B — CHECKING CLUTCH PRESSURES

7. Bring the transmission to normal operating temperature of 71–93°C (160–200°F). Check for fluid leaks in the added pressure gauge/transducer lines. Repair leaks as needed. Be sure that fluid level is correct.

B. Recording Data

1. Use the Pro-Link® 9000 diagnostic tool, which allows checking of individual range clutch pressures, with the vehicle stationary. Consult Appendix N or the Pro-Link® 9000 operating instructions for Action Request and select Clutch Test Mode. Follow instructions to check clutch pressures in individual ranges.

NOTE: *Check lockup clutch pressure by driving the vehicle in a range where lockup can be obtained. Record the pressure values at the engine speed and sump fluid temperature values shown in Table B-1. The lockup clutch is functioning correctly when engine speed and turbine speed values are equal as recorded from the Pro-Link® 9000.*

2. Consult Table B-1 and locate the transmission model that you are testing.
3. Operate the transmission at the conditions shown in Table B-1 and record engine speed, transmission sump fluid temperature, main hydraulic pressure, and clutch pressures in the ranges where a problem is suspected.

Table B-1. Clutch Pressure Test Conditions

Transmission Model/ Test Type	Engine rpm	Sump Fluid Temperature	Range	Clutches Pressurized
All (except MD 3070) — Idle Check	580–620	71–93°C (160–200°F)	Neutral Reverse 1C 2C (2nd range start)	C5 C3 C5 C1 C5 C1 C4
MD 3070 — Idle Check	580–620	71–93°C (160–200°F)	Neutral Reverse LowC 1C	C5 C3 C5 C3 C6 C1 C5
MD (except 3070) B 300/B 400 — High Speed	2080–2120	71–93°C (160–200°F)	Reverse Neutral 1C 2C 2L 3L 4L 5L 6L	C3 C5 C5 C1 C5 C1 C4 C1 C4 LU C1 C3 LU C1 C2 LU C2 C3 LU C2 C4 LU

APPENDIX B — CHECKING CLUTCH PRESSURES

Table B-1. Clutch Pressure Test Conditions (cont'd)

Transmission Model/ Test Type	Engine rpm	Sump Fluid Temperature	Range	Clutches Pressurized
MD 3070 — High Speed	2080-2120	71-93°C (160-200°F)	Reverse	C3 C5
			Neutral	C5
			LowC	C3 C6
			1C	C1 C5
			2C	C1 C4
			2L	C1 C4 LU
			3L	C1 C3 LU
			4L	C1 C2 LU
			5L	C2 C3 LU
			6L	C2 C4 LU
HD/B 500 — High Speed	1780-1820	71-93°C (160-200°F)	Reverse	C3 C5
			Neutral	C5
			1C	C1 C5
			2C	C1 C4
			2L	C1 C4 LU
			3L	C1 C3 LU
			4L	C1 C2 LU
			5L	C2 C3 LU
			6L	C2 C4 LU

C. Comparing Recorded Data to Specifications

1. Be sure that engine speed and transmission sump fluid temperatures were within the values specified in Table B-1.
2. Compare the main pressure and clutch pressure data, recorded in Step B, with the specifications in Table B-2.
3. If clutch pressures are within specifications, return the transmission and vehicle to their original configuration and proceed with electrical troubleshooting.
4. If clutch pressures are not within specification, take corrective action to replace the internal parts of the transmission necessary to correct the problem. (Refer to the Transmission Service Manual for the model being checked.)
5. Recheck pressure values after the transmission has been repaired.
6. Return the transmission to its original configuration. (Remove instrumentation and reinstall any components removed for the pressure testing.)

APPENDIX B — CHECKING CLUTCH PRESSURES

**Table B-2. Main Pressure and Clutch Pressure Specifications
(Sump Fluid Temperature Same as in Table B-1)**

Transmission Model/Test Type	Engine rpm	Range	Clutches Applied	Main Press. Spec kPa/[psi]	Range Clutch Press. Spec* kPa/[psi]	LU Clutch Press. Spec kPa/[psi]	D'BOX MAIN Press. Spec kPa/[psi]
MD — Idle (except 3070)	580–620	Neutral	C5	1500–1900 [218–276]			
		Reverse	C3 C5	1500–1900 [218–276]			
		1C	C1 C5	1300–1900 [189–276]			
		2C	C1 C4	1300–1900 [189–276]			
MD 3070 — Idle		Neutral	C5	1500–1900 [218–276]	1480–1900 [215–276]		
		Reverse	C3 C5	1500–1900 [218–276]	1480–1900 [215–276]		
		LowC	C3 C6	1500–1900 [218–276]	1480–1900 [215–276]		
		1C	C1 C5	1500–1900 [218–276]	1280–1900 [186–276]		
MD — High Speed (except 3070)	2080–2120	Neutral	C5	1500–2300 [218–334]	0–35 (C5) [0–5]		
		Reverse	C3 C5	1500–2300 [218–334]	0–35 (C3) [0–5] 0–35 (C5) [0–5]		
		1C	C1 C5	1500–2100 [218–305]	0–80 (C1) [0–11.6] 0–35 (C5) [0–5]		
		2C	C1 C4	1500–2100 [218–305]	0–80 (C1) [0–11.6] 0–35 (C4) [0–5]		
		2L	C1 C4 LU	1000–1400 [145–203]	0–80 (C1) [0–11.6] 0–35 (C4) [0–5]	950–1400 [138–203]	

* Subtract clutch pressure from main pressure; the difference must fall within the specifications given (unless a pressure range is supplied).

APPENDIX B — CHECKING CLUTCH PRESSURES

Table B-2. Main Pressure and Clutch Pressure Specifications
(Sump Fluid Temperature Same as in Table B-1) (cont'd)

Transmission Model/Test Type	Engine rpm	Range	Clutches Applied	Main Press. Spec kPa/[psi]	Range Clutch Press. Spec* kPa/[psi]	LU Clutch Press. Spec kPa/[psi]	D'BOX MAIN Press. Spec kPa/[psi]
MD — High Speed (except 3070) (cont'd)		3C	C1 C3	1500–2100 [218–305]	0–80 (C1) [0–11.6] 0–35 (C3) [0–5]		
		3L	C1 C3 LU	1000–1400 [145–203]	0–80 (C1) [0–11.6] 0–35 (C3) [0–5]	950–1400 [138–203]	
		4C	C1 C2	1500–2100 [218–305]	0–80 (C1) [0–11.6] 0–80 (C2) [0–11.6]		
		4L	C1 C2 LU	1000–1400 [145–203]	0–80 (C1) [0–11.6] 0–80 (C2) [0–11.6]	950–1400 [138–203]	
		5C	C2 C3	1150–1650 [167–239]	0–80 (C2) [0–11.6] 0–35 (C3) [0–5]		
		5L	C2 C3 LU	900–1300 [131–189]	0–80 (C2) [0–11.6] 0–35 (C3) [0–5]	850–1300 [124–189]	
		6C	C2 C4	1150–1650 [167–239]	0–80 (C2) [0–11.6] 0–35 (C4) [0–5]		
		6L	C2 C4 LU	900–1300 [131–189]	0–80 (C2) [0–11.6] 0–35 (C4) [0–5]	850–1300 [124–189]	
MD 3070 — High Speed		Neutral	C5	1500–2300 [218–334]	1480–2300 [215–334]		1400–1600 [200–232]
		Reverse	C3 C5	1500–2300 [218–334]	1480–2300 [215–334]		1400–1600 [200–232]

* Subtract clutch pressure from main pressure; the difference must fall within the specifications given (unless a pressure range is supplied).

APPENDIX B — CHECKING CLUTCH PRESSURES

Table B-2. Main Pressure and Clutch Pressure Specifications
(Sump Fluid Temperature Same as in Table B-1) (cont'd)

Transmission Model/Test Type	Engine rpm	Range	Clutches Applied	Main Press. Spec kPa/[psi]	Range Clutch Press. Spec* kPa/[psi]	LU Clutch Press. Spec kPa/[psi]	D'BOX MAIN Press. Spec kPa/[psi]
MD 3070 — High Speed (cont'd)		LowC	C3 C6	1500–2300 [218–334]	1480–2300 [215–334]		1400–1600 [200–232]
		1C	C1 C5	1500–2100 [218–305]	1480–2100 [215–305]		1400–1600 [200–232]
		2C	C1 C4	1500–2100 [218–305]	1480–2100 [215–305]		1400–1600 [200–232]
		2L	C1 C4 LU	1000–1400 [145–203]	980–1400 [142–203]	980–1400 [142–203]	1400–1600 [200–232]
		3C	C1 C3	1500–2100 [218–305]	1480–2100 [215–305]		1400–1600 [200–232]
		3L	C1 C3 LU	1000–1400 [145–203]	980–1400 [142–203]	980–1400 [142–203]	1400–1600 [200–232]
		4C	C1 C2	1500–2100 [218–305]	1480–2100 [215–305]		1400–1600 [200–232]
		4L	C1 C2 LU	1000–1400 [145–203]	980–1400 [142–203]	980–1400 [142–203]	1400–1600 [200–232]
		5C	C2 C3	1150–1650 [167–239]	1130–1650 [164–239]		1400–1600 [200–232]
		5L	C2 C3 LU	900–1300 [131–189]	880–1300 [128–189]	880–1300 [128–189]	1400–1600 [200–232]
		6C	C2 C4	1150–1650 [167–239]	1130–1650 [164–239]		1400–1600 [200–232]
		6L	C2 C4 LU	900–1300 [131–189]	880–1300 [128–189]	880–1300 [128–189]	1400–1600 [200–232]
HD — Idle	580–620	Neutral	C5	1500–2070 [218–300]			
		Reverse	C3 C5	1500–2070 [218–300]			
		1C	C1 C5	1300–1800 [189–260]			
		2C	C1 C4	1300–1800 [189–260]			

* Subtract clutch pressure from main pressure; the difference must fall within the specifications given (unless a pressure range is supplied).

APPENDIX B — CHECKING CLUTCH PRESSURES

Table B-2. Main Pressure and Clutch Pressure Specifications
(Sump Fluid Temperature Same as in Table B-1) (cont'd)

Transmission Model/Test Type	Engine rpm	Range	Clutches Applied	Main Press. Spec kPa/[psi]	Range Clutch Press. Spec* kPa/[psi]	LU Clutch Press. Spec kPa/[psi]	D'BOX MAIN Press. Spec kPa/[psi]
HD — High Speed	1780-1820	Neutral	C5	1800-2100 [261-305]	0-70 (C5)/[0-10]		
		Reverse	C3 C5	1800-2100 [261-305]	0-70 (C3)/[0-10] 0-70 (C5)/[0-10]		
		1C	C1 C5	1550-1800 [225-261]	0-70 (C1)/[0-10] 0-50 (C5)/[0-7]		
		2C	C1 C4	1550-1800 [225-261]	0-70 (C1)/[0-10] 0-35 (C4)/[0-5]		
		2L	C1 C4 LU	1050-1400 [152-203]	0-70 (C1)/[0-10] 0-35 (C4)/[0-5]	950-1400 [138-203]	
		3C	C1 C3	1550-1800 [225-261]	0-70 (C1)/[0-10] 0-50(C3)/[0-7]		
		3L	C1 C3 LU	1050-1400 [152-203]	0-70 (C1)/[0-10] 0-50 (C3)/[0-7]	950-1400 [138-203]	
		4C	C1 C2	1550-1800 [225-261]	0-70 (C1)/[0-10] 0-70 (C2)/[0-10]		
		4L	C1 C2 LU	1050-1400 [152-203]	0-70 (C1)/[0-10] 0-70 (C2)/[0-10]	950-1400 [138-203]	
		5C	C2 C3	1190-1380 [173-200]	0-70 (C2)/[0-10] 0-70 (C3)/[0-10]		
		5L	C2 C3 LU	900-1250 [131-181]	0-70 (C2)/[0-10] 0-70 (C3)/[0-10]	850-1300 [124-189]	
		6C	C2 C4	1190-1830 [173-200]	0-70 (C2)/[0-10] 0-35 (C4)/[0-5]		
		6L	C2 C4 LU	900-1250 [131-181]	0-70 (C2)/[0-10] 0-35 (C4)/[0-5]	850-1300 [124-189]	

* Subtract clutch pressure from main pressure; the difference must fall within the specifications given (unless a pressure range is supplied).

APPENDIX B — CHECKING CLUTCH PRESSURES

NOTES

APPENDIX C — SOLENOID AND CLUTCH CHART

BASIC CONFIGURATION

Range	Solenoid Non-Latching Modulating							Clutches					
	A N/O	B N/O	C N/C	D N/C	E N/C	F N/C	G N/C	C1	C2	C3	C4	C5	LU
6	X			X		0			X		X		0
5	X		X			0	X		X	X			0
4						0	X	X	X				0
3		X	X			0	X	X		X			0
2		X		X		0	X	X			X		0
1		X			X	0		X				X	0
N1	X	X		*	X	0						X	0
N2	X	X		X							X		
N3	X	X	X							X			
N4	X	X		X							X		
R	X	X	X		X					X		X	

NOTE: See Page C-2 for legend.

7-SPEED (T-CASE) CONFIGURATION

Range	Solenoid Non-Latching Modulating										Clutches							
	N/O	N/O	N/C	N/C	N/C	N/C	N/C	N/C	N/C	N/C								
	C1	C2	C3	C4	C5	LU	FWD	LOW	C6	DIF								
	A	B	C	D	E	F	G	N	J	H	C1	C2	C3	C4	C5	LU	C6	DIF
6	X			X		0				0		X		X		0		0
5	X		X			0	X			0		X	X			0		0
4						0	X			0	X	X				0		0
3		X	X			0	X			0	X		X			0		0
2		X		X		0	X			0	X			X		0		0
1		X			X	0				0	X				X	0		0
LO	X					0	X	X	X	0			X			0	X	0
N1	X	X		*	X					0					X			0
N2	X	X		X			X			0			X					0
N3	X	X	X				X			0			X					0
N4	X	X		X			X			0			X					0
R	X	X	X		X					0			X		X			0

NOTE: See Page C-2 for legend.

APPENDIX C — SOLENOID AND CLUTCH CHART

LEGEND

- X Electrically ON with respect to solenoids; hydraulically applied with respect to clutches.
- (Blank) Electrically OFF with respect to solenoids; hydraulically OFF with respect to clutches.
- 0 Optional ON or OFF.
- * If diagnostics indicate that turbine speed is below a calibration value (150 rpm) when transmission input speed is greater than the minimum calculation value and N1 (Neutral) has been selected and commanded, then Solenoid D must be turned ON. Otherwise, Solenoid D is turned OFF in N1 (Neutral).

APPENDIX D — WIRE/CONNECTOR CHART

The connector information in this appendix is provided for the convenience of the servicing technician. The connector illustration and pin identifications for connection to Allison Transmission components will be accurate. Allison Transmission components are the ECU, speed sensors, retarder connectors, transmission connectors, and shift selectors. Other kinds of connectors for optional or customer-furnished components are provided based on typical past practice for an Allison-designed system.

Contact St. Clair Technologies, Inc. or your vehicle manufacturer for information on connectors not found in this appendix.

APPENDIX D — WIRE/CONNECTOR CHART

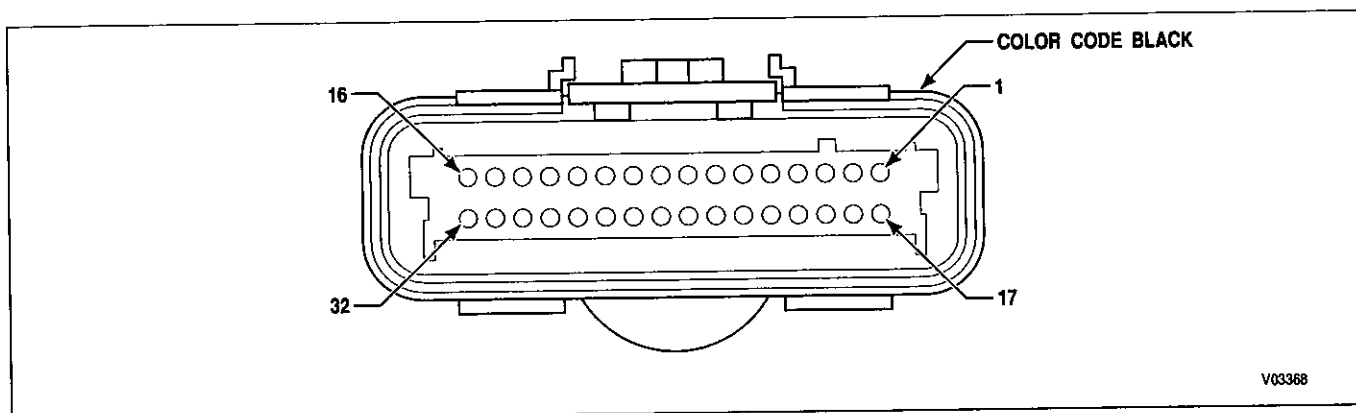

Figure D-1. ECU Connector "S"

ECU CONNECTOR "S" (BLACK)

Terminal No.	Color	Wire No.	Description	Termination Point(s)
1	White	142-S1	Serial Communication Interface, High	DDRP-J, DDRD-A, OBDII-7
2	Tan	159-S2	Diagnostic Communication Link (ISO9141)	VIWS-A
3	Pink	124-S3	Sensor Power	RMR-C, PSS-N, SSS-N
4	Yellow	146-S4	Ignition Sense	VIWS-E, DDRP-H, DDRD-C, OBDII-16
5	Orange	170-S5	Primary Shift Selector, Data Bit 1	PSS-A
6	Green	171-S6	Primary Shift Selector, Data Bit 2	PSS-B
7	Blue	172-S7	Primary Shift Selector, Data Bit 4	PSS-C
8	Yellow	173-S8	Primary Shift Selector, Data Bit 8	PSS-D
9	Tan	174-S9	Primary Shift Selector, Parity	PSS-E
10	Green	175-S10	Shift Selector Mode Input	PSS-M, SSS-M
11	Yellow	119-S11	General Purpose Input 4	VIWS-M
12	Green	182-S12	CAN Controller Shield (J1939)	J1939C
13	Pink	183-S13	CAN Controller, High (J1939)	J1939A
14	Blue	180-S14	Shift Selector Display	PSS-S, SSS-S
15	Orange	176-S15	General Purpose Output 6	PSS-L, SSS-L, VIWS-L
16	Pink	136-S16	Battery Power	PSS-R, SSS-R
17	Blue	151-S17	Serial Communication Interface, Low	DDRP-K, DDRD-B, OBDII-15
18	Tan	166-S18	General Purpose Output 7	VIWS-N
19	Green	135-S19	Analog Ground	RMR-A
20	Yellow	164-S20	Retarder Modulation Request	RMR-B
21	Orange	190-S21	Secondary Shift Selector, Data Bit 1	SSS-A
22	Green	191-S22	Secondary Shift Selector, Data Bit 2	SSS-B
23	Blue	192-S23	Secondary Shift Selector, Data Bit 4	SSS-C
24	Yellow	193-S24	Secondary Shift Selector, Data Bit 8	SSS-D
25	Tan	194-S25	Secondary Shift Selector, Parity	SSS-E
26	Blue	169-S26	General Purpose Input 12	VIWS-S
27	Blue	163-S27	General Purpose Input 6	VIWS-R
28	Yellow	126-S28	General Purpose Input 9	VIWS-C
29	Gray	184-S29	CAN Controller, Low (J1939)	J1939-B
30	Tan	157-S30	Vehicle Speed	VIWS-D
31	Green	115-S31	Check Transmission	VIWS-B
32	Gray	143-S32	Battery Ground	PSS-P, SSS-P, VIWS-P, DDRP-A, DDRD-E, OBDII-5

APPENDIX D — WIRE/CONNECTOR CHART

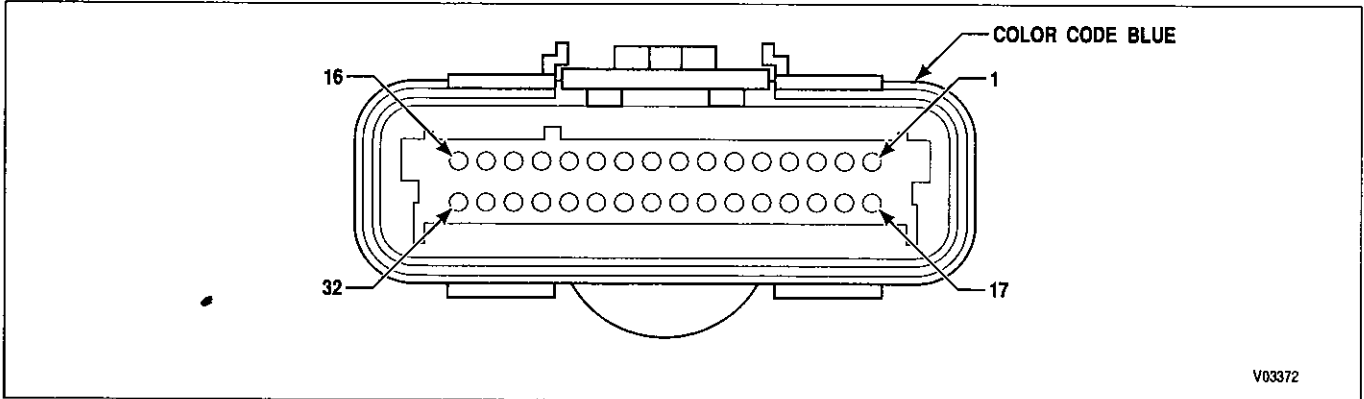

Figure D-2. ECU Connector "T"

ECU CONNECTOR "T" (BLUE)

Terminal No.	Color	Wire No.	Description	Termination Point(s)
1	Orange	102-T1	Solenoid Power, Solenoids A, D, and J (MD 3070 only)	TRANS-A
2	Tan	121-T2	Solenoid Power, Solenoids B and E	TRANS-H
3	Green	107-T3	Solenoid Power, Solenoid F	TRANS-E
4	White	120-T4	A Solenoid, Low	TRANS-G
5	Green	103-T5	C Solenoid, Low	TRANS-B
6	Tan	129-T6	E Solenoid, Low	TRANS-K
7	White	104-T7	G Solenoid, Low	TRANS-C
8	Blue	111-T8	J Solenoid, Low	TRANS-e
9	Pink	124-T9	Sensor Power	TRANS-D, TPS-C, RMR-C
10	Blue	156-T10	Throttle Position Sensor	TPS-B
11	Yellow	164-T11	Retarder Modulation Request	RMR-B
12	White	162-T12	C3 Pressure Switch Input	TRANS-X
13	Yellow	195-T13	Transmission Identification	TRANS-W
14	Tan	141-T14	Engine Speed Sensor, High	NE-A
15	Orange	149-T15	Turbine Speed Sensor, High	NT-A (HD), TRANS-V (MD)
16	Yellow	139-T16	Output Speed Sensor, High	NO-A, TCASE-C (MD 3070), RMOD-C (MDR)
17	Yellow	130-T17	Solenoid Power, Solenoids C and G	TRANS-L
18				
19	Yellow	116-T19	Solenoid Power, Solenoids H and N	HSOL-B, NSOL-B, TRANS-g, TCASE-B (MD 3070), RMOD-B (MDR)
20	Orange	128-T20	B Solenoid, Low	TRANS-J
21	Blue	131-T21	D Solenoid, Low	TRANS-M
22	White	110-T22	F Solenoid, Low	TRANS-F
23	White	127-T23	H Solenoid, Low	HSOL-A (HD), RMOD-A (MDR), TCASE-A (MD 3070)
24	Blue	101-T24	N Solenoid, Low	NSOL-A (HD and MD), TRANS-f (MD 3070)
25	Green	135-T25	Analog Ground	RMR-A, RTEMP-B (HD), RMOD-F (MD)
26	Blue	165-T26	Oil Level Sensor Input	TRANS-Y
27	Tan	147-T27	Sump Temperature Sensor Input	TRANS-P
28	Orange	138-T28	Retarder Temperature Sensor Input	RTEMP-A (HD), RMOD-E (MD)
29				
30	Orange	150-T30	Engine Speed Sensor, Low	NE-B
31	Blue	140-T31	Turbine Speed Sensor, Low	NT-B, TRANS-U (MD)
32	Green	148-T32	Output Speed Sensor, Low	NO-B, TCASE-D (MD 3070), RMOD-D (MDR)

APPENDIX D — WIRE/CONNECTOR CHART

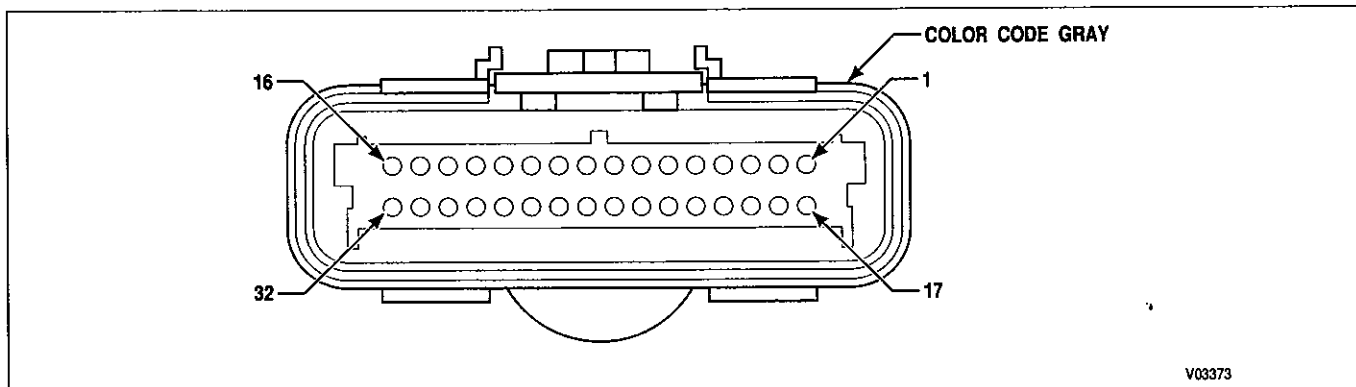

Figure D-3. ECU Connector "V"

ECU CONNECTOR "V" (GRAY)

Terminal No.	Color	Wire No.	Description	Termination Point(s)
1	Pink	136-V1	Battery Power	VIM-E1
2	White	114-V2	General Purpose Output 1	VIM-F3
3	Orange	132-V3	General Purpose Output 2	VIM-B1
4	White	113-V4	Reverse Warning	VIM-F2
5	White	167-V5	General Purpose Output 8	VIWV-V
6	Tan	123-V6	Neutral Start	VIM-D1
7				
8	Pink	124-V8	Sensor Power	TPS-C
9	Blue	179-V9	Engine Water Temperature	VIWV-M
10	Blue	156-V10	Throttle Position Sensor	TPS-B
11	Green	155-V11	General Purpose Input 1	VIWV-A
12	Yellow	153-V12	General Purpose Input 2	VIWV-B
13	Blue	118-V13	General Purpose Input 3	VIWV-C
14	Tan	177-V14	General Purpose Input 10	VIWV-S
15				
16	Pink	136-V16	Battery Power	VIM-E2
17	Gray	143-V17	Battery Ground	VIM-A1
18	White	125-V18	General Purpose Output 4	VIM-C2
19	Green	105-V19	General Purpose Output 5	VIWV-E
20	Tan	157-V20	Vehicle Speed	VIM-B2
21				
22	Tan	112-V22	General Purpose Output 3	VIM-D2
23				
24	Green	135-V24	Analog Ground	TPS-A, VIWV-N
25	Gray	144-V25	Chassis Ground	RNGTRM
26	Yellow	146-V26	Ignition Sense	VIM-F1
27	White	154-V27	General Purpose Input 5	VIWV-D
28	Orange	178-V28	General Purpose Input 11	VIWV-R
29	Orange	137-V29	General Purpose Input 7	VIWV-U
30	Green	117-V30	General Purpose Input 8	VIWV-P
31	Yellow	161-V31	Digital Ground (GPI)	VIWV-L
32	Gray	143-V32	Battery Ground	VIM-A2

APPENDIX D — WIRE/CONNECTOR CHART

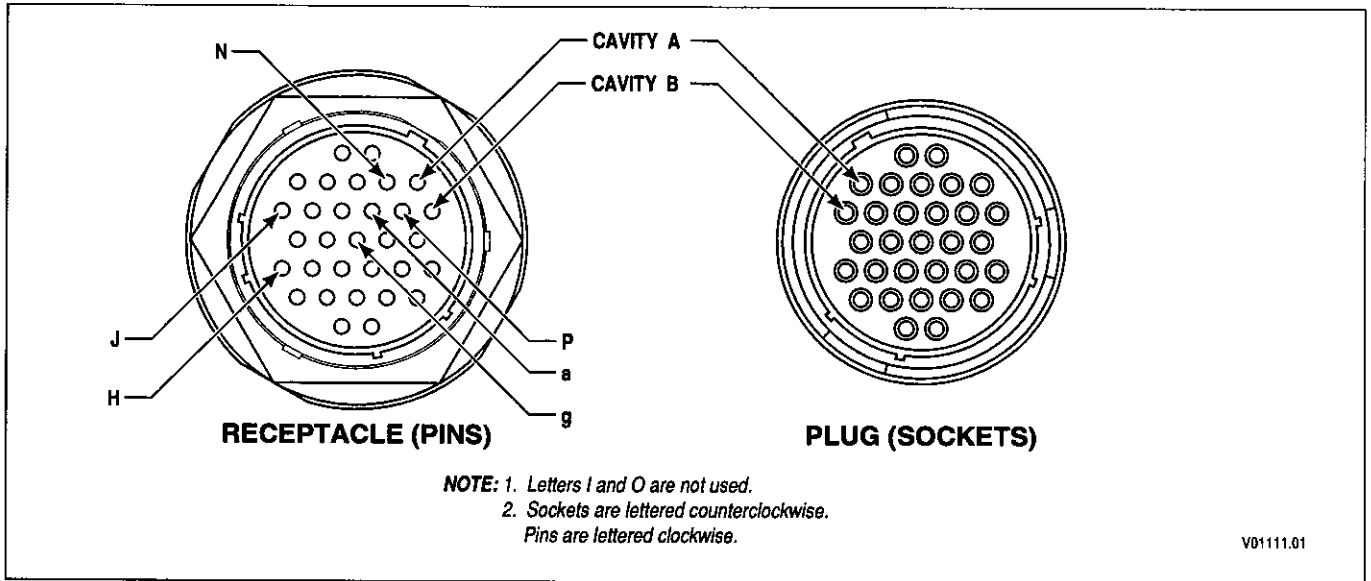

Figure D-4. Deutsch Bulkhead Connector, ECD

BULKHEAD CONNECTOR FOR “S” HARNESS (Plug With Sockets, Receptacle With Pins)

Terminal No.*	Color	Wire No.	Description	Termination Points*
A	Tan	159-S2	Diagnostic Communication Link (ISO 9141)	ECU-S2, VIWS-A
B	Green	115-S31	Check Transmission	ECU-S31, VIWS-B
C	Yellow	126-S28	General Purpose Input 9	ECU-S28, VIWS-C
D	Pink	124-S3	Sensor Power	ECU-S3, RMR-C, PSS-N, SSS-N
E	Yellow	146-S4	Ignition Sense	ECU-S4, VIWS-E, DDRP-H, DDRD-C, OBDII-16
F	Orange	170-S5	Primary Shift Selector, Data Bit 1	ECU-S5, PSS-A
G	Pink	136-S16	Battery Power	ECU-S16, PSS-R, SSS-R
H	White	142-S1	Serial Communication Interface, High	ECU-S1, DDRP-J, DDRD-A, OBDII-7, SCI-A
J	Blue	172-S7	Primary Shift Selector, Data Bit 4	ECU-S7, PSS-C
K	Blue	151-S17	Serial Communication Interface, Low	ECU-S17, DDRP-K, DDRD-B, OBDII-15, SCI-B
L	Orange	176-S15	General Purpose Output 6	ECU-S15, PSS-L, SSS-L, VIWS-L
M	Yellow	119-S11	General Purpose Input 4	ECU-S11, VIWS-M
N	Green	135-S19	Analog Ground	ECU-S19, RMR-A
P	Gray	143-S32	Battery Ground	ECU-S32, PSS-P, SSS-P, VIWS-P, DDRP-A, DDRD-E, OBDII-5
Q	Green	171-S6	Primary Shift Selector, Data Bit 2	ECU-S6, PSS-B
R	Blue	163-S27	General Purpose Input 6	ECU-S27, VIWS-R
S	Yellow	173-S8	Primary Shift Selector, Data Bit 8	ECU-S8, PSS-D
T	Tan	174-S9	Primary Shift Selector, Parity	ECU-S9, PSS-E
U	Green	175-S10	Shift Selector Mode Input	ECU-S10, PSS-M, SSS-M
V	Blue	180-S14	Shift Selector Display	ECU-S14, PSS-S, SSS-S
W	Tan	166-S18	General Purpose Output 7	ECU-S18, VIWS-N
X	Blue	169-S26	General Purpose Input 12	ECU-S26, VIWS-S
Y	Orange	190-S21	Secondary Shift Selector, Data Bit 1	ECU-S21, SSS-A

* Terminal number and termination points shown only apply when an Allison Transmission recommended harness configuration and bulkhead connector are used.

APPENDIX D — WIRE/CONNECTOR CHART

BULKHEAD CONNECTOR FOR “S” HARNESS (Plug With Sockets, Receptacle With Pins) *(cont'd)*

Terminal No.*	Color	Wire No.	Description	Termination Points*
Z				
a	Yellow	164-S20	Retarder Modulation Request	ECU-S20, RMR-B
b	Green	191-S22	Secondary Shift Selector, Data Bit 2	ECU-S22, SSS-B
c	Blue	192-S23	Secondary Shift Selector, Data Bit 4	ECU-S23, SSS-C
d	Tan	157-S30	Vehicle Speed	ECU-S30, VIWS-D
e	Yellow	193-S24	Secondary Shift Selector, Data Bit 8	ECU-S24, SSS-D
f	Tan	194-S25	Secondary Shift Selector, Parity	ECU-S25, SSS-E
g				

BULKHEAD CONNECTOR FOR “T” HARNESS (Receptacle With Sockets, Plug With Pins)

Terminal No.*	Color	Wire No.	Description	Termination Points*
A	Orange	102-T1	Solenoid Power, Solenoids A, D, and J (MD 3070 only)	ECU-T1, TRANS-A
B	Green	103-T5	C Solenoid, Low	ECU-T5, TRANS-B
C	White	104-T7	G Solenoid, Low	ECU-T7, TRANS-C
D	Pink	124-T9	Sensor Power	ECU-T9, TRANS-D, TPS-C, RMR-C
E	Green	107-T3	Solenoid Power, Solenoid F	ECU-T3, TRANS-E
F	White	110-T22	F Solenoid, Low	ECU-T22, TRANS-F
G	White	120-T4	A Solenoid, Low	ECU-T4, TRANS-G
H	Tan	121-T2	Solenoid Power, Solenoids B and E	ECU-T2, TRANS-H
J	Orange	128-T20	B Solenoid, Low	ECU-T20, TRANS-J
K	Tan	129-T6	E Solenoid, Low	ECU-T6, TRANS-K
L	Yellow	130-T17	Solenoid Power, Solenoids C and G	ECU-T17, TRANS-L
M	Blue	131-T21	D Solenoid, Low	ECU-T21, TRANS-M
N	Green	135-T25	Analog Ground	ECU-T25, TRANS-N, TPS-A, RMR-A, RTEMP-B (HD), RMOD-F (MD)
P	Tan	147-T27	Sump Temperature Sensor Input	ECU-T27, TRANS-P
Q	Green	148-T32	Output Speed Sensor, Low	ECU-T32, NO-B, TCASE-D (MD 3070), RMOD-D (MDR)
R	Yellow	139-T16	Output Speed Sensor, High	ECU-T16, NO-A, TCASE-C (MD 3070), RMOD-C (MDR)
S	Orange	150-T30	Engine Speed Sensor, Low	ECU-T30, NE-B
T	Tan	141-T14	Engine Speed Sensor, High	ECU-T14, NE-A
U	Blue	140-T31	Turbine Speed Sensor, Low	ECU-T31, NT-B (HD), TRANS-U (MD)
V	Orange	149-T15	Turbine Speed Sensor, High	ECU-T15, NT-A (HD), TRANS-V (MD)
W	Yellow	195-T13	Transmission Identification	ECU-T13, TRANS-W
X	White	162-T12	C3 Pressure Switch Input	ECU-T12, TRANS-X
Y	Blue	165-T26	Oil Level Sensor Input	ECU-T26, TRANS-Y
Z				
a	Yellow	164-T11	Retarder Modulation Request	ECU-T11, RMR-B
b	Blue	156-T10	Throttle Position Sensor	ECU-T10, TPS-B
c	White	127-T23	H Solenoid, Low	ECU-T23, HSOL-A (HD), RMOD-A (MDR), TCASE-A (MD 3070)

* Terminal number and termination points shown only apply when an Allison Transmission recommended harness configuration and bulkhead connector are used.

APPENDIX D — WIRE/CONNECTOR CHART

BULKHEAD CONNECTOR FOR “T” HARNESS (Receptacle With Sockets, Plug With Pins) *(cont'd)*

Terminal No.*	Color	Wire No.	Description	Termination Points*
d	Orange	138-T28	Retarder Temperature Sensor Input	ECU-T28, RTEMP-A (HD), RMOD-E (MD)
e	Blue	111-T8	J Solenoid, Low	ECU-T8, TRANS-e
f	Blue	101-T24	N Solenoid, Low	ECU-T24, NSOL-A (HD and MD), TRANS-f (MD 3070)
g	Yellow	116-T19	Solenoid Power, Solenoids H and N	ECU-T19, HSOL-B, NSOL-B, TRANS-g, TCASE-B (MD 3070), RMOD-B (MDR)

BULKHEAD CONNECTOR FOR “V” HARNESS (Receptacle With Sockets, Plug With Pins)

Terminal No.*	Color	Wire No.	Description	Termination Points*
A	Green	155-V11	General Purpose Input 1	ECU-V11, VIWV-A
B	Yellow	153-V12	General Purpose Input 2	ECU-V12, VIWV-B
C	Blue	118-V13	General Purpose Input 3	ECU-V13, VIWV-C
D	Pink	124-V8	Sensor Power	ECU-V8, TPS-C
E	Green	105-V19	General Purpose Output 5	ECU-V19, VIWV-E
F	Gray	143-V32	Battery Ground	ECU-V32, VIM-A2
G	Gray	143-V17	Battery Ground	ECU-V17, VIM-A1
H	Tan	112-V22	General Purpose Output 3	ECU-V22, VIM-D2
J	White	114-V2	General Purpose Output 1	ECU-V2, VIM-F3
K	Tan	123-V6	Neutral Start	ECU-V6, VIM-D1
L	Yellow	161-V31	Digital Ground (GPI)	ECU-V31, VIWV-L
M	Blue	179-V9	Engine Water Temperature	ECU-V9, VIWV-M
N	Green	135-V24	Analog Ground	ECU-V24, TPS-A, VIWV-N
P	Green	117-V30	General Purpose Input 8	ECU-V30, VIWV-P
Q	White	113-V4	Reverse Warning	ECU-V4, VIM-F2
R	Orange	178-V28	General Purpose Input 11	ECU-V28, VIWV-R
S	Tan	177-V14	General Purpose Input 10	ECU-V14, VIWV-S
T				
U	Orange	137-V29	General Purpose Input 7	ECU-V29, VIWV-U
V	White	167-V5	General Purpose Output 8	ECU-V5, VIWV-V
W	Pink	136-V16	Battery Power	ECU-V16, VIM-E2
X	Tan	157-V20	Vehicle Speed	ECU-V20, VIM-B2
Y	White	125-V18	General Purpose Output 4	ECU-V18, VIM-C2
Z				
a				
b	Blue	156-V10	Throttle Position Sensor	ECU-V10, TPS-B
c				
d	White	154-V27	General Purpose Input 5	ECU-V27, VIWV-D
e	Yellow	146-V26	Ignition Sense	ECU-V26, VIM-F1
f	Orange	132-V3	General Purpose Output 2	ECU-V3, VIM-B1
g	Pink	136-V1	Battery Power	ECU-V1, VIM-E1

* Terminal number and termination points shown only apply when an Allison Transmission recommended harness configuration and bulk-head connector are used.

APPENDIX D — WIRE/CONNECTOR CHART

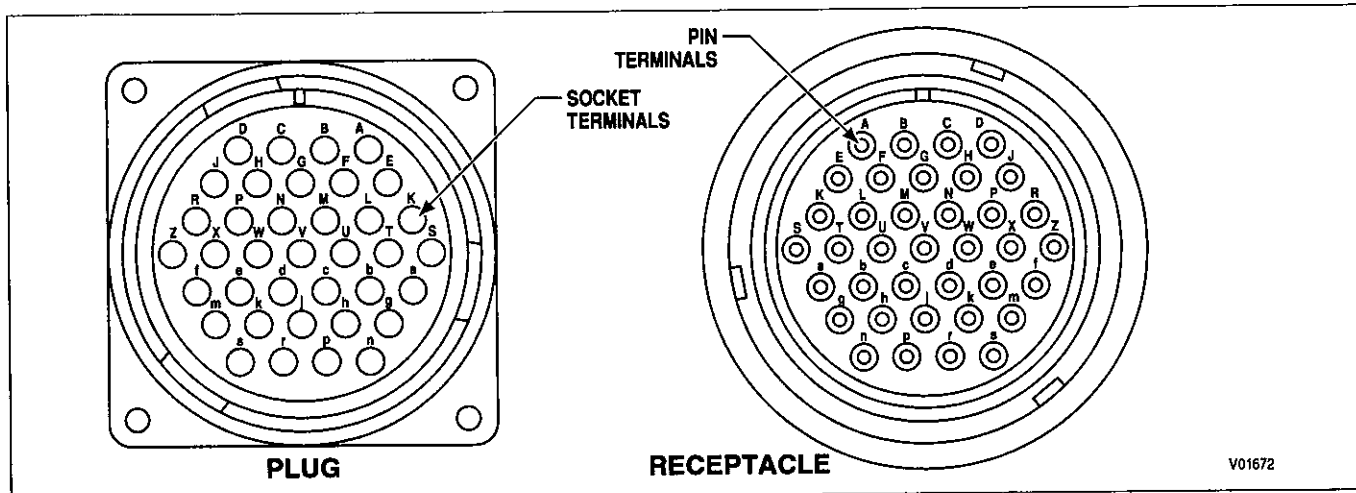

Figure D-5. Cannon 37-Way FMTV Bulkhead Connector

CANNON 37-WAY BULKHEAD CONNECTOR (FMTV ONLY)

Terminal No.	Color	Wire No.	Description	Termination Point(s)
A	Blue	101-T24	N Solenoid Low	Trans-f; ECU-T24
B	Orange	102-T1	A, D, J Solenoid Power	Trans-A; ECU-T1
C	Green	103-T5	C Solenoid Low	Trans-B; ECU-T5
D	White	104-T7	G Solenoid Low	Trans-C; ECU-T7
E	Pink	106	Sensor Power	Trans-D; TPS-C; RMR-C; 124-T9 Splice
F	Green	107-T3	F Solenoid Power	Trans-E; ECU-T3
G				
H	White	110-T22	F Solenoid Low	Trans-F; ECU-T22
J	Green	111-T8	J Solenoid Low	Trans-e; ECU-T8
K	Yellow	116-T19	H, N Solenoid Power	Trans-g; ECU-T19;
L		201	Spare	
M	White	120-T4	A Solenoid Low	Trans-G; ECU-T4
N	Tan	121-T2	B, E Solenoid Power	Trans-H; ECU-T2
P	White	127-T23	H Solenoid Low	T-case-A; ECU-T23
R	Pink	124-T9	Sensor Power	TPS-C; ECU-T9
S	Yellow	127	H Solenoid Power	T-case-B; 116-T19 Splice
T	Orange	128-T20	B Solenoid Low	Trans-J; ECU-T20
U	Tan	129-T6	E Solenoid Low	Trans-K; ECU-T6
V	Yellow	130-T17	C, G Solenoid Power	Trans-L; ECU-T17
W	Blue	131-T21	D Solenoid Low	Trans-M; ECU-T21
X		202	Spare	
Z	Green	135-T25	Analog Ground	TPS-A; ECU-T25
a	Green	135B-T25	Analog Ground	Trans-N; 135-T25 Splice
b				
c				
d	Tan	147-T27	Sump Temp Input	Trans-P; ECU-T27
e		203	Spare	
f	Blue	156-T10	TPS	TPS-B; ECU-T10
g	Green	148-T32	Output Speed-Low	T-case-D; ECU-T32
h(in)	Yellow	195-T13	TransID	ECU-T13

APPENDIX D — WIRE/CONNECTOR CHART

CANNON 37-WAY BULKHEAD CONNECTOR (FMTV ONLY) *(cont'd)*

Terminal No.	Color	Wire No.	Description	Termination Point(s)
h(out)	Yellow	161A	TransID	Trans-W
j	White	162-T12	C3PS Input	Trans-X; ECU-T12
k	Blue	165-T26	OLS Input	Trans-Y; ECU-T26
m	Tan	141-T14	Engine Speed-High	NE-A; ECU-T14
n	Yellow	139-T16	Output Speed-High	T-case-C; ECU-T16
p	Orange	149-T15	Turbine Speed-High	Trans-V; ECU-T15
r	Blue	140-T31	Turbine Speed-Low	Trans-U; ECU-T31
s	Orange	150-T30	Engine Speed-Low	NE-B; ECU-T30

APPENDIX D — WIRE/CONNECTOR CHART

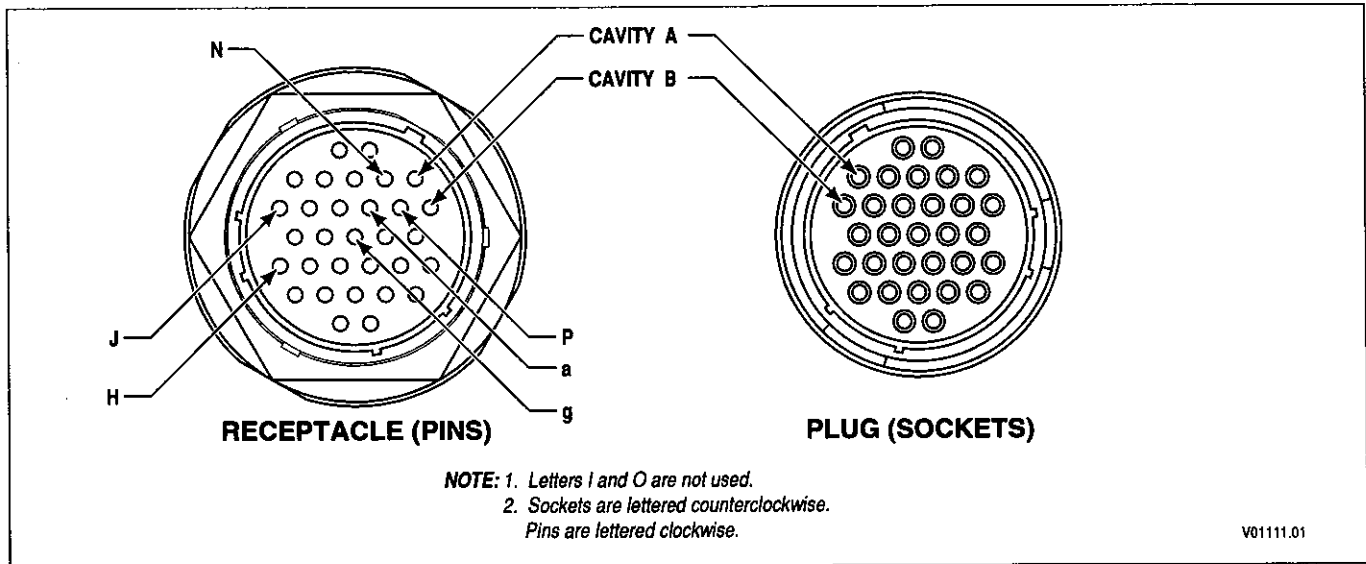

Figure D-6. Deutsch Transmission Connector, ECD

DEUTSCH TRANSMISSION CONNECTOR (Plugs With Sockets, Receptacles With Pins)

Terminal No.*	Color	Wire No.	Description	Termination Points*
A	Orange	102-T1	Solenoid Power, Solenoids A, D, and J	ECU-T1, ASOL-B, DSOL-B, JSOL-B
B	Green	103-T5	C Solenoid, Low	ECU-T5, CSOL-A
C	White	104-T7	G Solenoid, Low	ECU-T7, GSOL-A
D	Pink	124-T9	Sensor Power	ECU-T9, TPS-C, RMR-C, OLS-D
E	Green	107-T3	Solenoid Power, Solenoid F	ECU-T3, FSOL-A
F	White	110-T22	F Solenoid, Low	ECU-T22, FSOL-B
G	White	120-T4	A Solenoid, Low	ECU-T4, ASOL-A
H	Tan	121-T2	Solenoid Power, Solenoids B and E	ECU-T2, BSOL-B, ESOL-B
J	Orange	128-T20	B Solenoid, Low	ECU-T20, BSOL-A
K	Tan	129-T6	E Solenoid, Low	ECU-T6, ESOL-A
L	Yellow	130-T17	Solenoid Power, Solenoids C and G	ECU-T17, GSOL-B, CSOL-B
M	Blue	131-T21	D Solenoid, Low	ECU-T21, DSOL-A
N	Green	135-T25	Analog Ground	ECU-T25, TPS-A, RMR-A, RTEMP-B (HD), RMOD-F (MD), C3PS-B, OILT-LO, OLS-B
P	Tan	147-T27	Sump Temperature Sensor Input	ECU-T27, OILT-HI
Q				
R				
S				
T				
U	Blue	140-T31	Turbine Speed Sensor, Low (MD, MD7 only)	ECU-T31, NT-B
V	Orange	149-T15	Turbine Speed Sensor, High (MD, MD7 only)	ECU-T15, NT-A
W	Yellow	195-T13	Transmission Identification	ECU-T13, AGND
X	White	162-T12	C3 Pressure Switch Input	ECU-T12, C3PS-A

* Terminal number and termination points shown only apply when an Allison Transmission recommended harness configuration and bulk-head connector are used.

APPENDIX D — WIRE/CONNECTOR CHART

DEUTSCH TRANSMISSION CONNECTOR (Plugs With Sockets, Receptacles With Pins) (cont'd)

Terminal No.*	Color	Wire No.	Description	Termination Points*
Y	Blue	165-T26	Oil Level Sensor Input	ECU-T26, OLS-A
Z				
a				
b				
c				
d				
e	Blue	111-T8	J Solenoid, Low (MD7 only)	ECU-T8, JSOL-A
f	Blue	101-T24	N Solenoid, Low (MD7 only)	ECU-T24, NSOL-A
g	Yellow	116-T19	Solenoid Power, Solenoids H and N (MD7 only)	ECU-T19, HSOL-B, NSOL-B

* Terminal number and termination points shown only apply when an Allison Transmission recommended harness configuration and bulk-head connector are used.

APPENDIX D — WIRE/CONNECTOR CHART

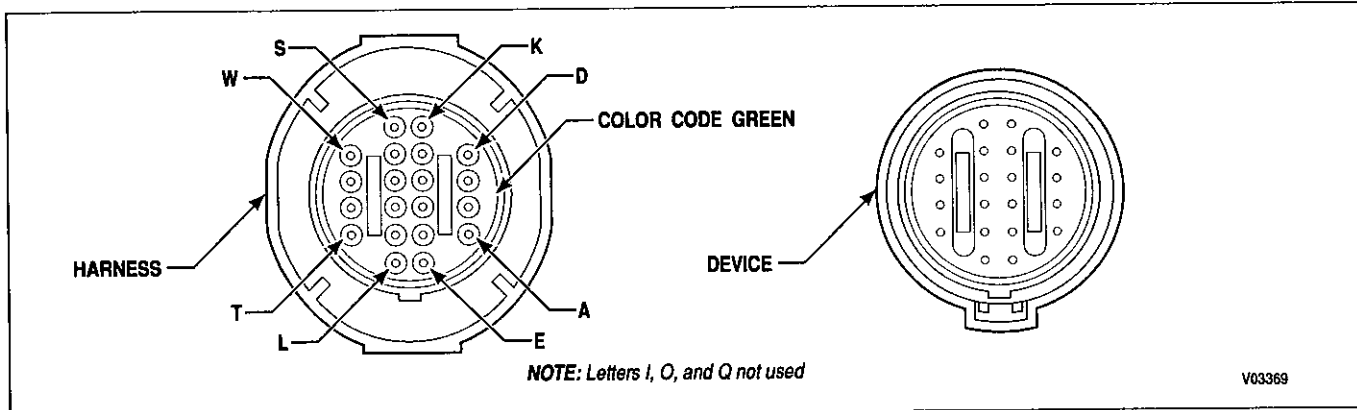

Figure D-7. Remote Selector Connector

REMOTE SHIFT SELECTOR CONNECTOR — PRIMARY SELECTOR

Terminal No.*	Color	Wire No.	Description	Termination Point(s)*
A	Orange	170-S5	Primary Shift Selector, Data Bit 1	ECU, S5
B	Green	171-S6	Primary Shift Selector, Data Bit 2	ECU, S6
C	Blue	172-S7	Primary Shift Selector, Data Bit 4	ECU, S7
D	Yellow	173-S8	Primary Shift Selector, Data Bit 8	ECU, S8
E	Tan	174-S9	Primary Shift Selector, Parity	ECU, S9
F				
G				
H				
J				
K				
L	Orange	176-S15	General Purpose Output 6	VIWS-L, SSS-L
M	Green	175-S10	Shift Selector Mode Output	SSS-M
N	Pink	124-S3	Sensor Power	RMR-C, SSS-N
P	Gray	143-S32	Battery Ground	VIWS-P, SSS-P, DDRP-A, DDRD-E, or OBDII-5
R	Pink	136-S16	Battery Power	SSS-R
S	Blue	180-S14	Shift Selector Display	SSS-S
T	White	186	Dimmer Input A	SSS-T
U	Yellow	187	Dimmer Input B	SSS-U
V	Gray	188	Dimmer Ground	SSS-V
W				

* Terminal number and termination points shown only apply when an Allison Transmission recommended harness configuration and bulk-head connector are used.

APPENDIX D — WIRE/CONNECTOR CHART

REMOTE SHIFT SELECTOR CONNECTOR — SECONDARY SELECTOR

Terminal No.*	Color	Wire No.	Description	Termination Point(s)*
A	Orange	190-S5	Secondary Shift Selector, Data Bit 1	ECU, S5
B	Green	191-S6	Secondary Shift Selector, Data Bit 2	ECU, S6
C	Blue	192-S7	Secondary Shift Selector, Data Bit 4	ECU, S7
D	Yellow	193-S8	Secondary Shift Selector, Data Bit 8	ECU, S8
E	Tan	194-S9	Secondary Shift Selector, Parity	ECU, S9
F				
G				
H				
J				
K				
L	Orange	176-S15	General Purpose Output 6	VIWS-L, SSS-L
M	Green	175-S10	Shift Selector Mode Output	SSS-M
N	Pink	124-S3	Sensor Power	RMR-C, SSS-N
P	Gray	143-S32	Battery Ground	VIWS-P, SSS-P, DDRP-A, DDRD-E, or OBDII-5
R	Pink	136-S16	Battery Power	SSS-R
S	Blue	180-S14	Shift Selector Display	SSS-S
T	White	186	Dimmer Input A	SSS-T
U	Yellow	187	Dimmer Input B	SSS-U
V	Gray	188	Dimmer Ground	SSS-V
W				

* Terminal number and termination points shown only apply when an Allison Transmission recommended harness configuration and bulk-head connector are used.

APPENDIX D — WIRE/CONNECTOR CHART

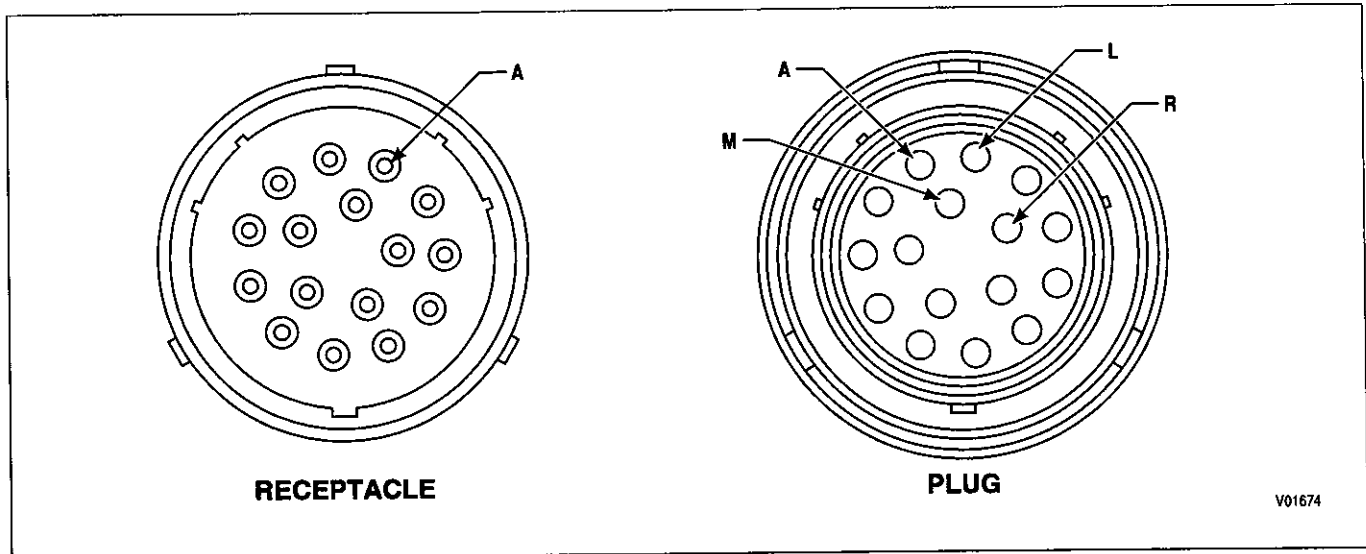

Figure D-8. Optional Deutsch Sensor Harness Connector

OPTIONAL DEUTSCH SENSOR HARNESS CONNECTOR

Terminal No.*	Color	Wire No.	Description	Termination Point(s)*
A				
B				
C	Green	135-T25	Analog Ground	ECU-T25, TRANS-N, RTEMP-B (HD), RMOD-F (MD), TPS-A, RMR-A
D	Orange	138-T28	Retarder Temperature Sensor Input	ECU-T28, RTEMP-A (HD), RMOD-E (MD)
E	Yellow	116-T19	Solenoid Power, Solenoids H and N	ECU-T19, HSOL-B, NSOL-B
F	White	127-T23	H Solenoid, Low	ECU-T23, HSOL-A
G	Yellow	116-T19	Solenoid Power, Solenoids H and N	ECU-T19, HSOL-B, NSOL-B
H	Blue	101-T24	N Solenoid, Low	ECU-T24, NSOL-B
J				
K				
L	Blue	140-T31	Turbine Speed Sensor, Low	ECU-T31, NT-B (HD)
M	Orange	149-T15	Turbine Speed Sensor, High	ECU-T15, NT-A (HD)
N	Orange	150-T30	Engine Speed Sensor, Low	ECU-T30, NE-B
P	Tan	141-T14	Engine Speed Sensor, High	ECU-T14, NE-A
R	Green	148-T32	Output Speed Sensor, Low	ECU-T32, NO-B
S	Yellow	139-T16	Output Speed Sensor, High	ECU-T16, NO-A

* Terminal number and termination points shown only apply when an Allison Transmission recommended harness configuration and bulk-head connector are used.

APPENDIX D — WIRE/CONNECTOR CHART

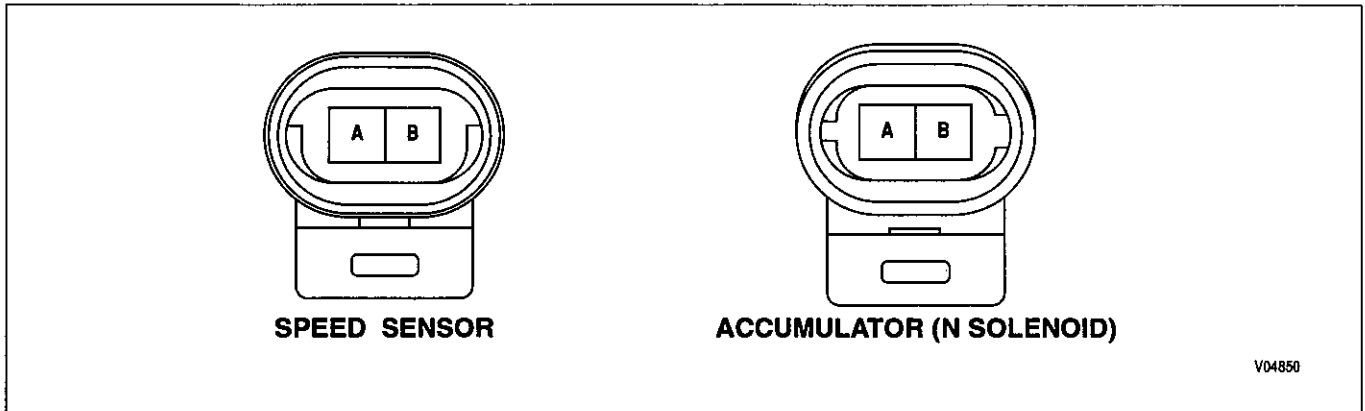

Figure D-9. Speed Sensor Connector

ENGINE SPEED SENSOR CONNECTOR

Terminal No.	Color	Wire No.	Description	Termination Point(s)
A	Tan	141-T14	Engine Speed Sensor Hi	ECU-T14
B	Orange	150-T30	Engine Speed Sensor Lo	ECU-T30

TURBINE SPEED SENSOR CONNECTOR (HD/B 500 ONLY)

Terminal No.	Color	Wire No.	Description	Termination Point(s)
A	Orange	149-T15	Turbine Speed Sensor Hi	ECU-T15
B	Blue	140-T31	Turbine Speed Sensor Lo	ECU-T31

OUTPUT SPEED SENSOR CONNECTOR

Terminal No.	Color	Wire No.	Description	Termination Point(s)
A	Yellow	139-T16	Output Speed Sensor Hi	ECU-T16
B	Green	148-T32	Output Speed Sensor Lo	ECU-T32

ACCUMULATOR (N) SOLENOID

Terminal No.	Color	Wire No.	Description	Termination Point(s)
A	Blue	101-T24	N Solenoid Lo	ECU-T24
B	Yellow	116-T19	N Solenoid Hi	ECU-T19

MD RETARDER (H SOLENOID, TID 2)

Terminal No.	Color	Wire No.	Description	Termination Point(s)
A	White	127-T23	H Solenoid Lo	ECU-T23
B	Yellow	116C-T19	H Solenoid Hi	ECU-T19

APPENDIX D — WIRE/CONNECTOR CHART

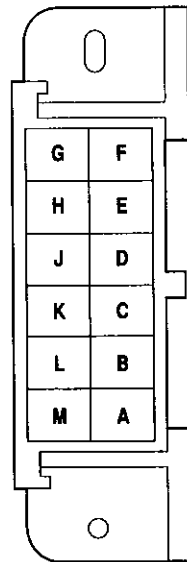

V00644.01

Figure D-10. Diagnostic Connector (Packard)

DIAGNOSTIC CONNECTOR

Terminal No.	Color	Wire No.	Description	Termination Point(s)
A	Gray	143-S32	Battery (-)	ECU-S32, VIWS-P, PSS-P, SSS-P
H	Yellow	146-S4	Ignition Signal (+)	ECU-S4, VIWS-E
J	White	142-S1	Serial Communication (+)	ECU-S1, SCI-A
K	Blue	151-S17	Serial Communication (-)	ECU-S17, SCI-B

APPENDIX D — WIRE/CONNECTOR CHART

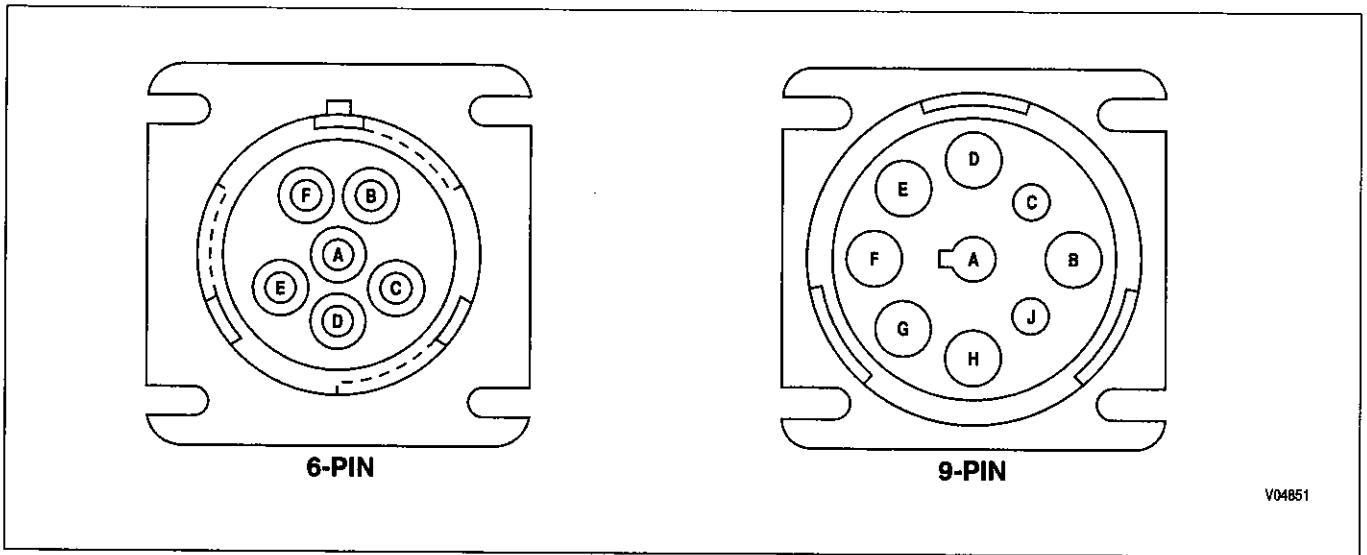

Figure D-11. Optional Deutsch DDR Connectors

OPTIONAL 6-PIN DIAGNOSTIC CONNECTOR

Terminal No.	Color	Wire No.	Description	Termination Point(s)
A	White	142-S1	Serial Communication (+)	ECU-S1, SCI-A
B	Blue	151-S17	Serial Communication (-)	ECU-S17, SCI-B
C	Yellow	146-S4	Ignition Signal (+)	ECU-S4, VIWS-E
D			Open	
E	Gray	143-S32	Battery (-)	ECU-S32, VIWS-P, PSS-P, SSS-P
F			Open	

OPTIONAL 9-PIN DIAGNOSTIC CONNECTOR

Terminal No.	Color	Wire No.	Description	Termination Point(s)
A	Gray	143-S32	Battery Ground (-)	ECU-S32, VIWS-P, PSS-P, SSS-P
B	Yellow	146-S4	Ignition Power (+)	ECU-S4, VIWS-E
B (Optional)	Pink	136-S16	Battery Power (+)	ECU-S16, PSS-R, SSS-R
C	Pink	183-S13	J1939 High	ECU-S13, J1939-A/H
D	Gray	184-S29	J1939 Low	ECU-S29, J1939-B/L
E	Green	182-S12	J1939 Shield/Ground	ECU-S12, J1939-C/S
F	White	142-S1	Serial Communication (+)	ECU-S1, SCI-A
G	Blue	151-S17	Serial Communication (-)	ECU-S17, SCI-B

APPENDIX D — WIRE/CONNECTOR CHART

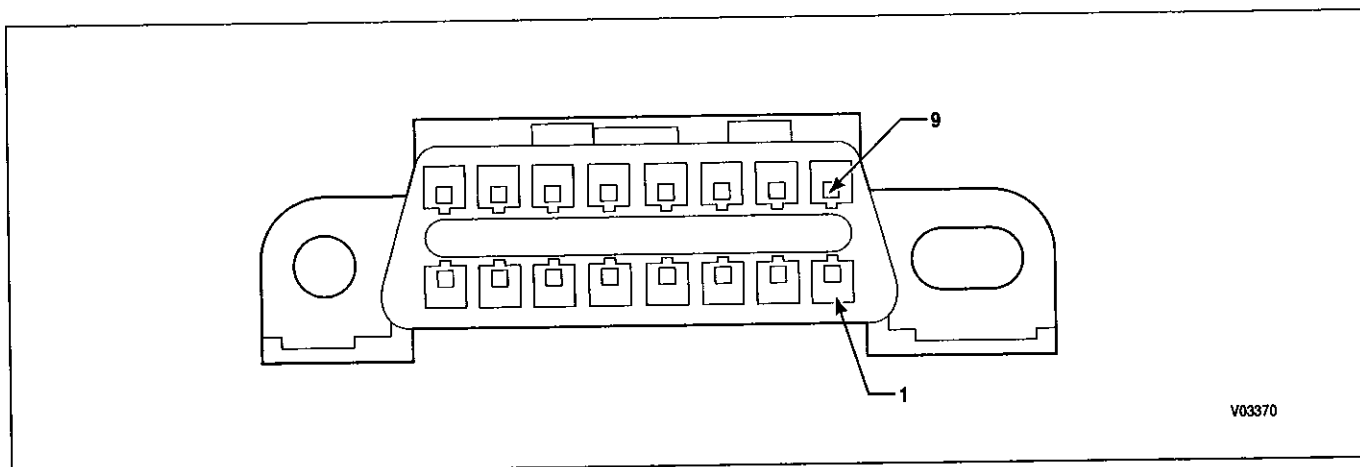

Figure D-12. GMC Connector for OBD-II DDR Adapter

OPTIONAL OBD-II DDR CONNECTOR

Terminal No.*	Color	Wire No.	Description	Termination Point(s)*
1				
2				
3				
4				
5	Gray	143-S32	Battery Ground (-)	ECU-S32, VIWS-P, PSS-P, SSS-P
6				
7	White	142-S1	Serial Communication Interface, Hi	ECU-S1, SCI-A
8				
9				
10				
11				
12				
13				
14				
15	Blue	151-S17	Serial Communication Interface, Lo	ECU-S17, SCI-B
16	Yellow	146-S4	Ignition Sense (+)	ECU-S4, VIWS-E

* Terminal number and termination points shown only apply when an Allison Transmission recommended harness configuration and bulk-head connector are used.

APPENDIX D — WIRE/CONNECTOR CHART

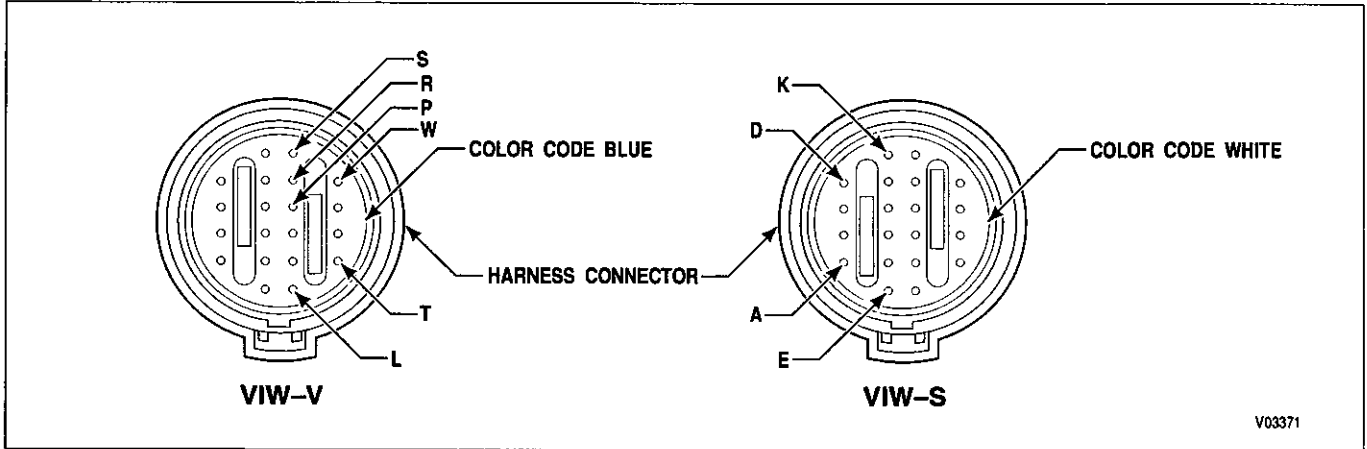

Figure D-13. VIW Connector (Packard Micro Pack)

VIW-V CONNECTOR

Terminal No.*	Color	Wire No.	Description	Termination Point(s)*
A	Green	155-V11	General Purpose Input 1	ECU-V11, VIWV-A
B	Yellow	153-V12	General Purpose Input 2	ECU-V12, VIWV-B
C	Blue	118-V13	General Purpose Input 3	ECU-V13, VIWV-C
D	White	154-V27	General Purpose Input 5	ECU-V27, VIWV-D
E	Green	105-V19	General Purpose Output 5	ECU-V19, VIWV-E
F				
G				
H				
J				
K				
L	Yellow	161-V31	Digital Ground (GPI)	ECU-V31, VIWV-L
M	Blue	179-V9	Engine Water Temperature	ECU-V9, VIWV-M
N	Green	135-V24	Analog Ground	ECU-V24, TPS-A, VIWV-N
P	Green	117-V30	General Purpose Input 8	ECU-V30, VIWV-P
R	Orange	178-V28	General Purpose Input 11	ECU-V28, VIWV-R
S	Tan	177-V14	General Purpose Input 10	ECU-V14, VIWV-S
T				
U	Orange	137-V29	General Purpose Input 7	ECU-V29, VIWV-U
V	White	167-V5	General Purpose Output 8	ECU-V5, VIWV-V
W				

* Terminal number and termination points shown only apply when an Allison Transmission recommended harness configuration and bulk-head connector are used.

APPENDIX D — WIRE/CONNECTOR CHART

VIW-S CONNECTOR

Terminal No.*	Color	Wire No.	Description	Termination Point(s) *
A	Tan	159-S2	Diagnostic Communication Link (ISO9141)	ECU-S2, VIWS-A
B	Green	115-S31	Check Transmission	ECU-S31, VIWS-B
C	Yellow	126-S28	General Purpose Input 9	ECU-S28, VIWS-C
D	Tan	157-S30	Vehicle Speed	ECU-S30, VIWS-D
E	Yellow	146-S4	Ignition Sense	ECU-S4, VIWS-E, DDRP-H, DDRD-C
F				
G				
H				
J				
K				
L	Orange	176-S15	General Purpose Output 6	ECU-S15, VIWS-L, PSS-L, SSS-L
M	Yellow	119-S11	General Purpose Input 4	ECU-S11, VIWS-M
N	Tan	166-S18	General Purpose Output 7	ECU-S18, VIWS-N
P	Gray	143-S32	Battery Ground	ECU-S32, VIWS-P, PSS-P, SSS-P, DDRP-A, DDRD-E
R	Blue	163-S27	General Purpose Input 6	ECU-S27, VIWS-R
S	Blue	169-S26	General Purpose Input 12	ECU-S26, VIWS-S
T	White	186	Dimmer Input A	VIWS-T, PSS-T, SSS-T
U	Yellow	187	Dimmer Input B	VIWS-U, PSS-U, SSS-U
V	Gray	188	Dimmer Ground	VIWS-V, PSS-V, SSS-V
W				

* Terminal number and termination points shown only apply when an Allison Transmission recommended harness configuration and bulk-head connector are used.

APPENDIX D — WIRE/CONNECTOR CHART

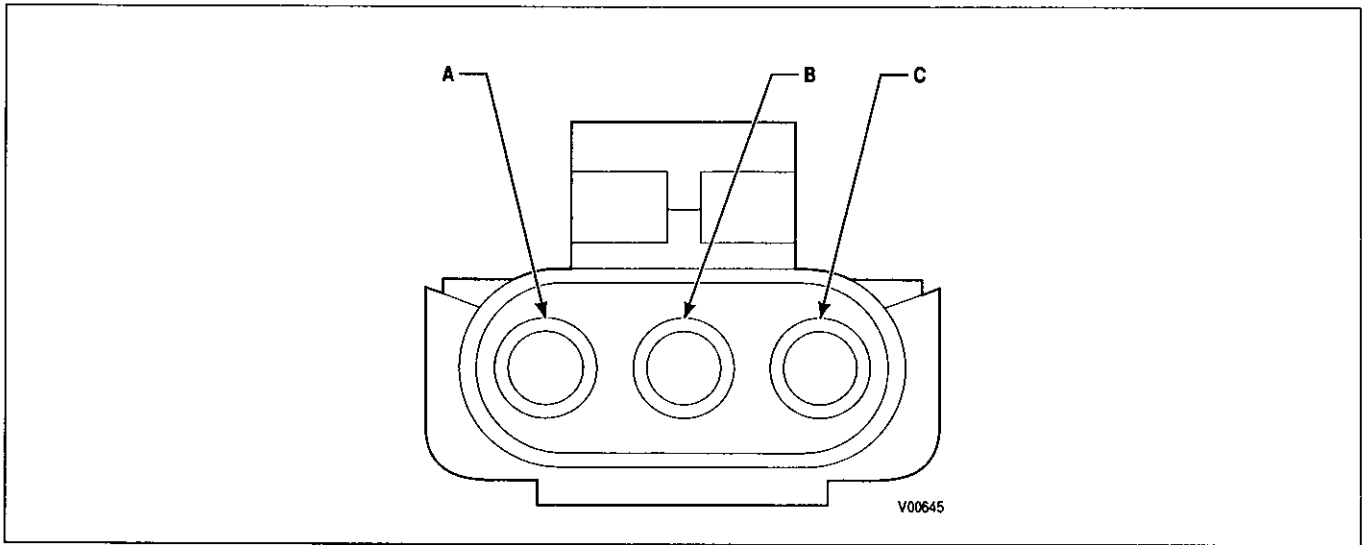
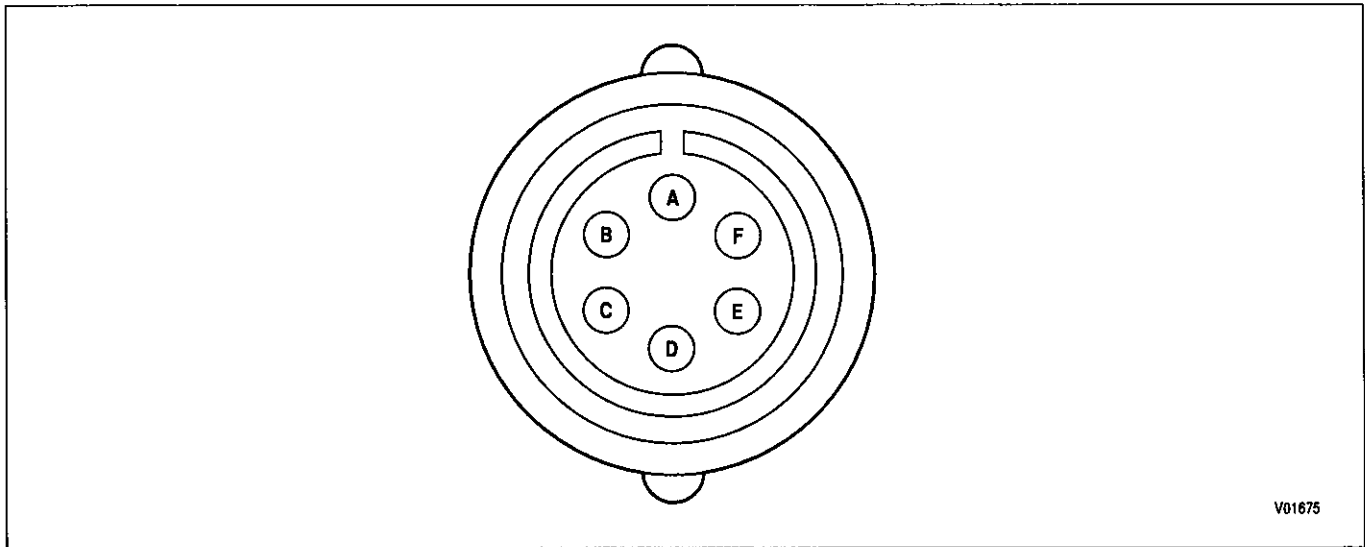

Figure D-14. TPS Connector

THROTTLE POSITION SENSOR CONNECTOR

Terminal No.	Color	Wire No.	Description	Termination Point(s)
A	Green	135-T25 or 135-V24	Analog Ground	ECU-T25 or V24; TRANS-N; RMR-A, RMOD-F or B; VIWV-N
B	Blue	156-T10 or V10	TPS Signal	ECU-T10 or V10
C	Pink	124-T9 or V8	TPS Hi	ECU-T9 or V8; RMR-C

APPENDIX D — WIRE/CONNECTOR CHART



V01675

Figure D-15. Transfer Case Connector

TRANSFER CASE CONNECTOR

Terminal No.	Color	Wire No.	Description	Termination Point(s)
A	White	127-T23	H (Diff Lock) Solenoid Lo	ECU-T23
B	Yellow	116N-T19	H (Diff Lock) Solenoid Hi	ECU-T19, TRANS-g
C	Yellow	139-T16	Output Speed Sensor Hi	ECU-T16
D	Green	148-T32	Output Speed Sensor Lo	ECU-T32

APPENDIX D — WIRE/CONNECTOR CHART

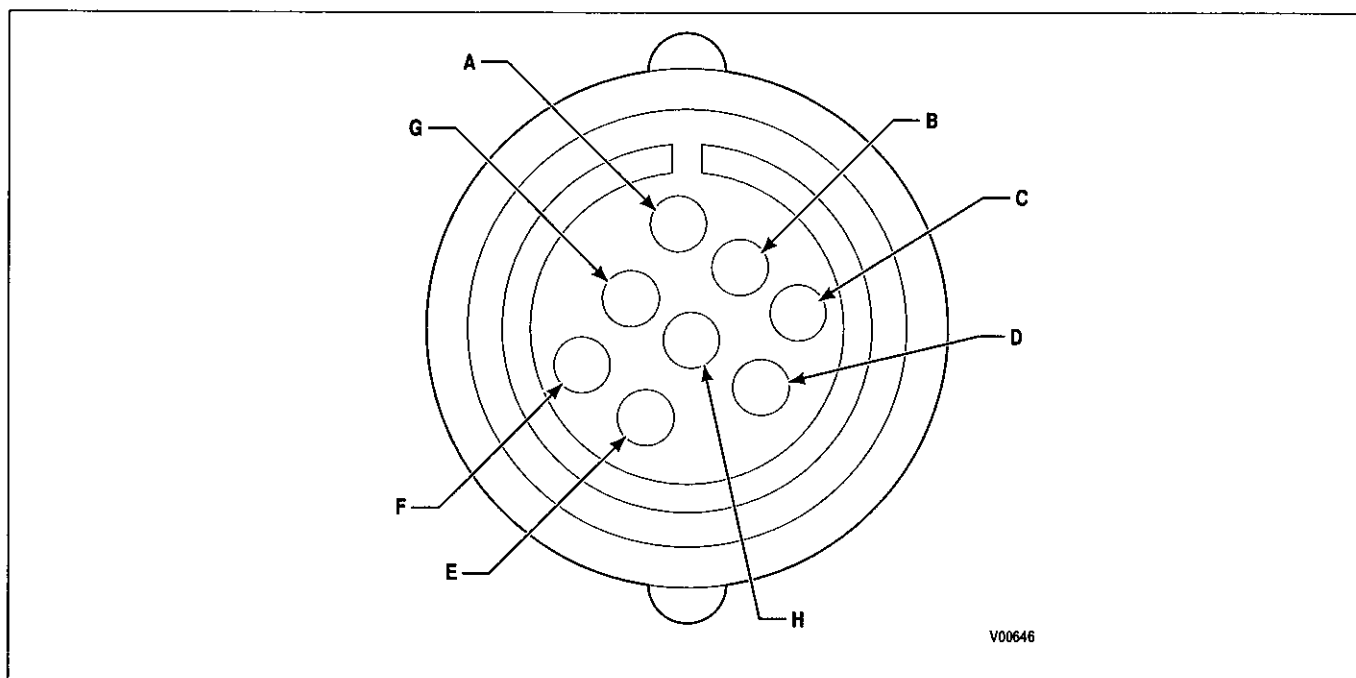

Figure D-16. Retarder Connector (MD/B 300/B 400 Pre-TransID and TID 1)

RETARDER CONNECTOR — MD/B 300/B 400 (Pre-TransID and TID 1)

Terminal No.	Color	Wire No.	Description	Termination Point(s)
A	White	127-T23	H (Rtdr Enable) Solenoid Lo	ECU-T23
B	Yellow	116-T19	H (Rtdr Enable) Solenoid Hi	ECU-T19, NSOL-B
C	Yellow	139-T16	Output Speed Sensor Hi	ECU-T16
D	Green	148-T32	Output Speed Sensor Lo	ECU-T32
E	Orange	138-T28	Retarder Temperature Input	ECU-T28
F	Green	135-T25	Analog Ground	ECU-T25; TRANS-N; TPS-A, RMR-A

APPENDIX D — WIRE/CONNECTOR CHART

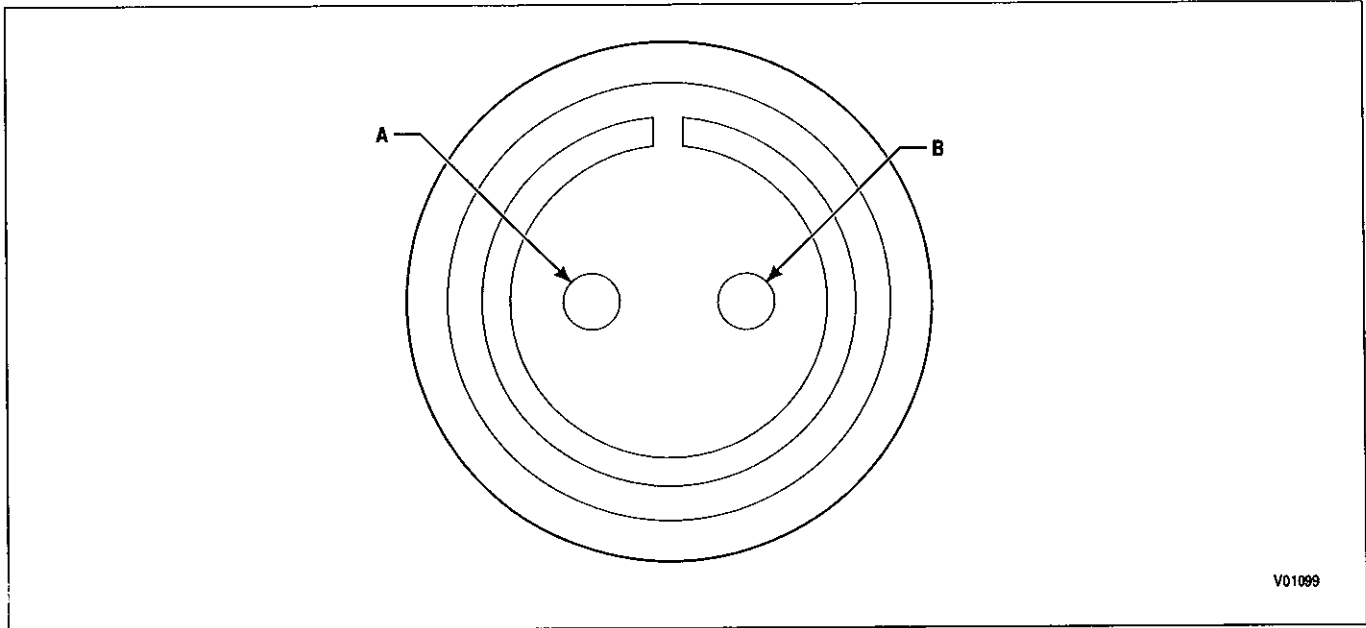

Figure D-17. Retarder Connector (HD/B 500)

RETARDER CONNECTOR — HD/B 500

Terminal No.	Color	Wire No.	Description	Termination Point(s)
A	White	127-T23	H (Retarder Enable) Solenoid Lo	ECU-T23
B	Yellow	116-T19	H (Retarder Enable) Solenoid Hi	ECU-T19, NSOL-B

APPENDIX D — WIRE/CONNECTOR CHART

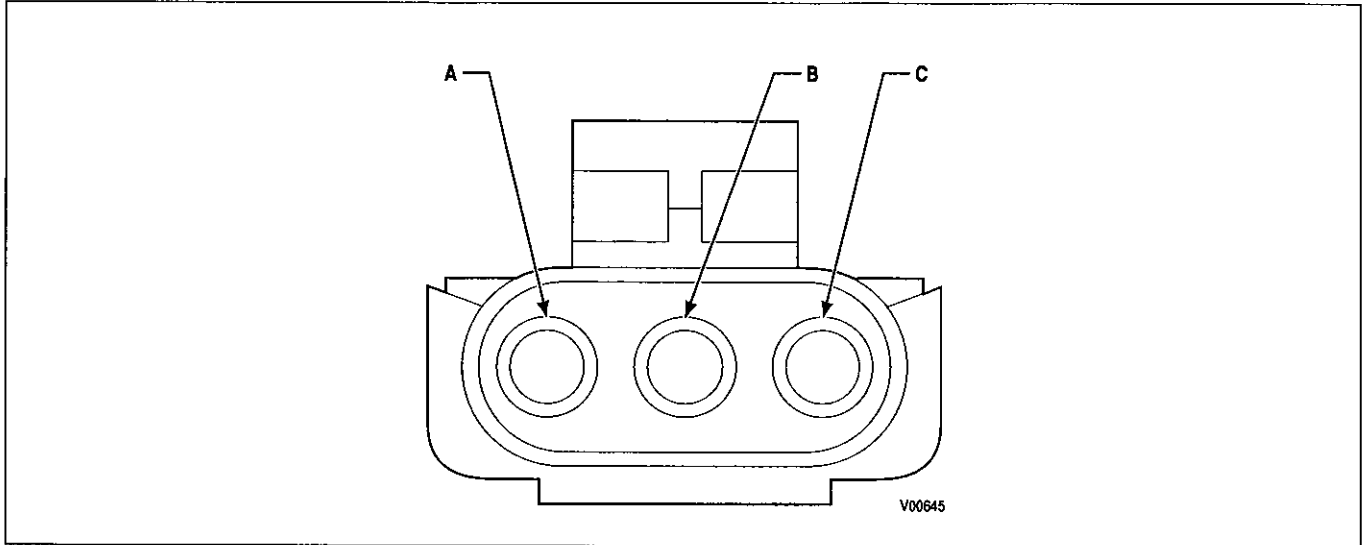
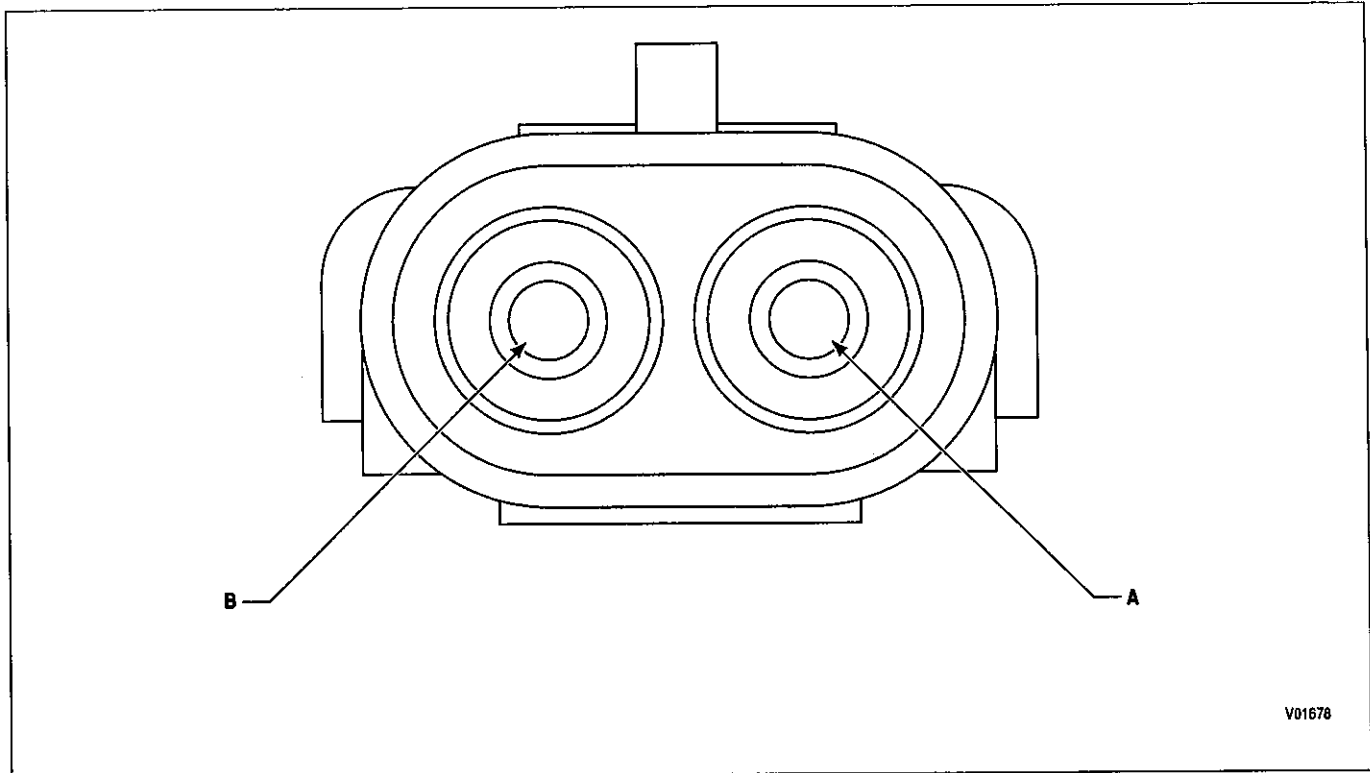

Figure D-18. Retarder Resistance Module/Interface Connector

RETARDER RESISTANCE MODULE/INTERFACE CONNECTOR

Terminal No.	Color	Wire No.	Description	Termination Point(s)
A	Green	135-T25 or S19	Analog Ground	ECU-T25 or S19; TRANS-N, RMOD-F; TPS-A
B	Yellow	164-T11 or S20	Retarder Mod.	ECU-T11 or S20
C	Pink	124-T9 or S3	Retarder Mod. Hi	ECU-T9 or S3; TRANS-D, PSS-N, SSS-N

APPENDIX D — WIRE/CONNECTOR CHART



V01678

Figure D-19. Retarder Temperature Sensor Connector (HD/B 500 Pre-TransID and TID 1)

**RETARDER TEMPERATURE SENSOR CONNECTOR — HD/B 500
(Pre-TransID and TransID 1)**

Terminal No.	Color	Wire No.	Description	Termination Point(s)
A	Orange	138-T28	Retarder Temperature Input	ECU-T28
B	Green	135-T25	Analog Ground	ECU-T25; TRANS-N; TPS-A; RMR-A

APPENDIX D — WIRE/CONNECTOR CHART

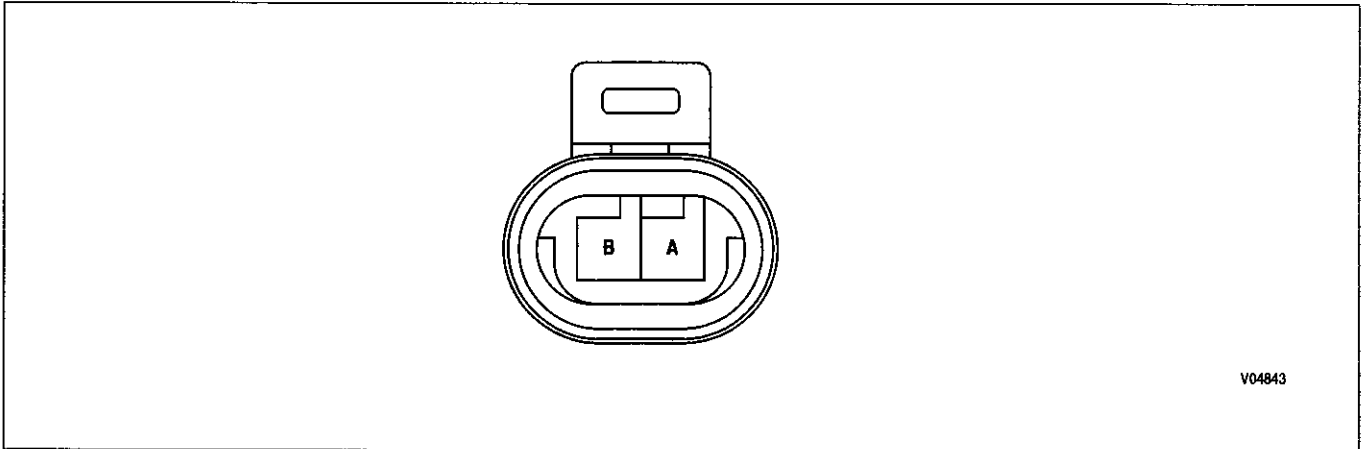

V04843

Figure D-20. Retarder Temperature Sensor Connector (MD/HD/B, TID 2)

RETARDER TEMPERATURE SENSOR CONNECTOR — MD/HD/B, TRANSID 2

Terminal No.	Color	Wire No.	Description	Termination Point(s)
A	Orange	138-T28	Retarder Temperature Input	ECU-T28
B	Green	135C-T25	Analog Ground	ECU-T25; TRANS-N; TPS-A

APPENDIX D — WIRE/CONNECTOR CHART

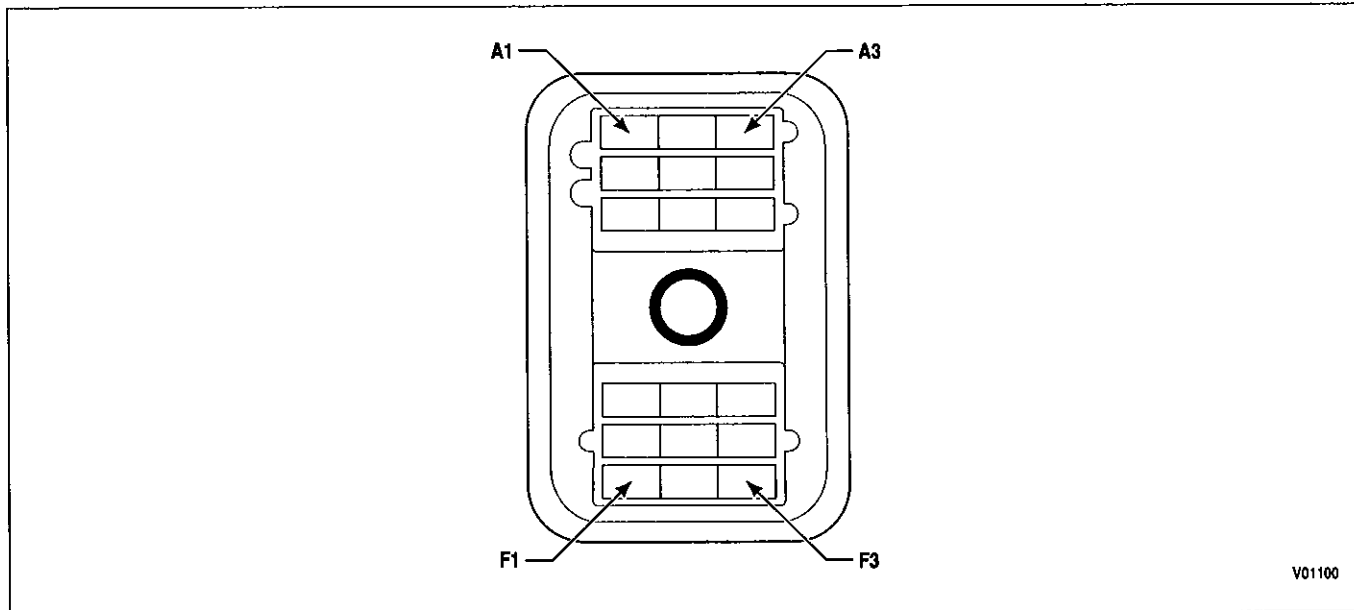

V01100

Figure D-21. VIM Connector (Harness)

VIM CONNECTOR (HARNESS)

Terminal No.	Color	Wire No.	Description	Termination Point(s)
A1	Gray	143-V17	Battery (-)	ECU-V17
A2	Gray	143-V32	Battery (-)	ECU-V32
A3			Reserved	
B1	Orange	132-V3	GPO 2	ECU-V3
B2	Tan	157-V20	Speedometer Signal	ECU-V20
B3			Reserved	
C1			Reserved	
C2	White	125-V18	GPO 4	ECU-V18
C3			Reserved	
D1	Tan	123-V6	Neutral Start	ECU-V6
D2	Tan	112-V22	GPO 3	ECU-V22
D3			Reserved	
E1	Pink	136-V1	Battery (+)	ECU-V1
E2	Pink	136-V16	Battery (+)	ECU-V16
E3			Reserved	
F1	Yellow	146-V26	Ignition Sense (+)	ECU-V26
F2	White	113-V4	Reverse Warning	ECU-V4
F3	White	114-V2	GPO 1	ECU-V2

APPENDIX D — WIRE/CONNECTOR CHART

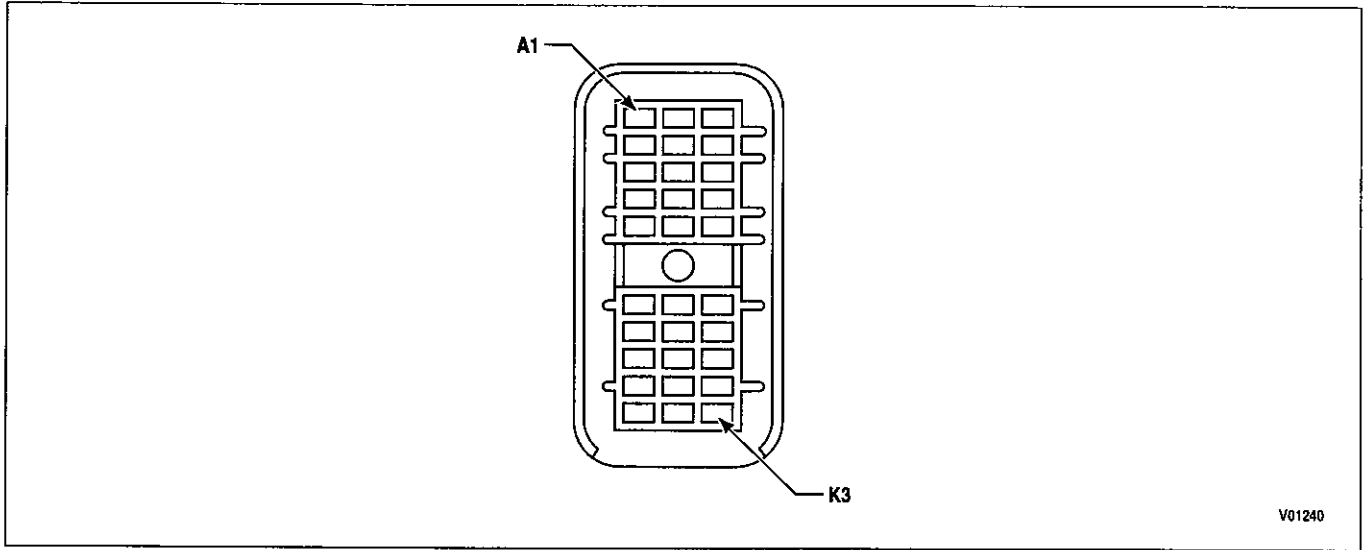

V01240

Figure D-22. VIM Connector (Harness)

VIM CONNECTOR (HARNESS 30-WAY)

Terminal No.	Color	Wire No.	Description	Termination Point(s)*
A1	Blue	313NO	Reverse Warning Relay — Normally Open	
A2	Yellow	314CM	Output Wire 114 Relay — Common	
A3	Blue	314NO	Output Wire 114 Relay — Normally Open	
B1	Yellow	313CM	Reverse Warning Relay — Common	
B2	Green	314NC	Output Wire 114 Relay — Normally Closed	
B3			Reserved	
C1	Orange	346	Ignition Power	
C2	Green	312NC	Output Wire 112 Relay — Normally Closed	
C3			Reserved	
D1	Green	325NC	Output Wire 125 Relay — Normally Closed	
D2	Green	332NC	Output Wire 132 Relay — Normally Closed	
D3			Reserved	
E1	Yellow	325CM	Output Wire 125 Relay — Common	
E2	Yellow	332CM	Output Wire 132 Relay — Common	
E3	Blue	332NO	Output Wire 132 Relay — Normally Open	
F1	Blue	323NO	Neutral Start Relay — Normally Open	
F2	Yellow	312CM	Output Wire 112 Relay — Common	
F3	Blue	312NO	Output Wire 112 Relay — Normally Open	
G1	Yellow	323CM	Neutral Start Relay — Common	
G2			Reserved	
G3			Reserved	
H1			Reserved	
H2	White	357UF	Speedometer — Unfiltered	
H3			Reserved	
J1	Pink	336A	Battery Power	
J2	Pink	336C	Battery Power	
J3			Reserved	
K1	Gray	343A	Battery Ground	
K2	Gray	343C	Battery Ground	
K3			Reserved	

* Termination Points are determined by OEM electrical system design.

APPENDIX D — WIRE/CONNECTOR CHART

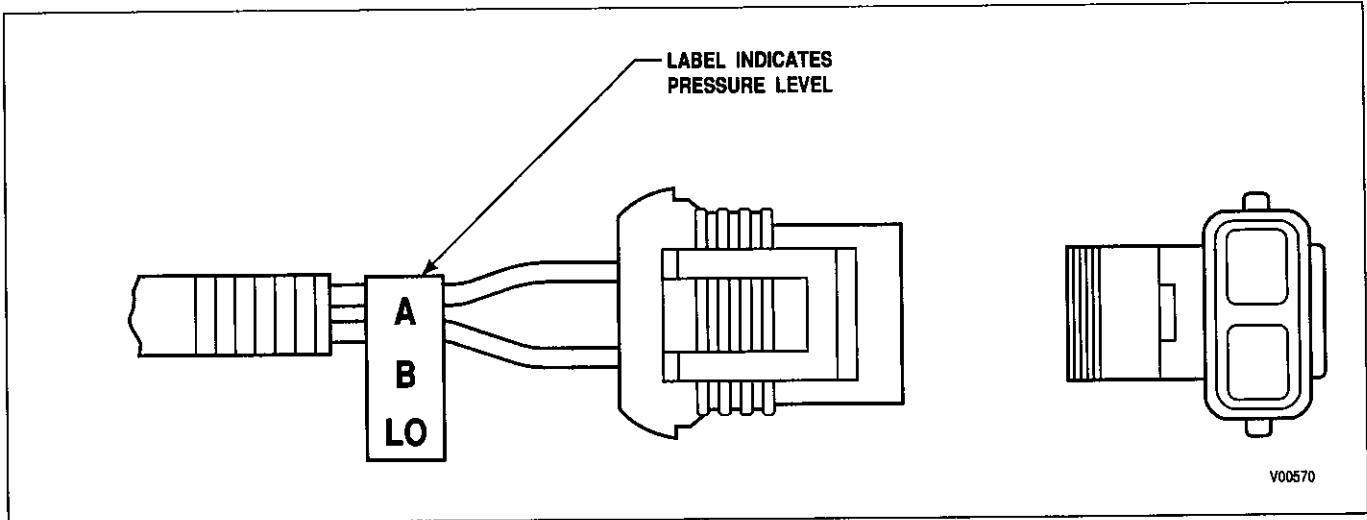

Figure D-23. Resistance Module Type 2 — Single Pressure Switch and SCI Interface

RESISTANCE MODULE TYPE 2

Terminal No.

- A
- B

SCI INTERFACE CONNECTOR

Terminal No.	Color	Wire No.	Description	Termination Point(s)
A	White	142-S1	Serial Communication Interface, Hi	ECU-S1, DDRP-J, DDRD-A
B	Blue	151-S17	Serial Communication Interface, Lo	ECU-S17, DDRP-K, DDRD-B

APPENDIX D — WIRE/CONNECTOR CHART

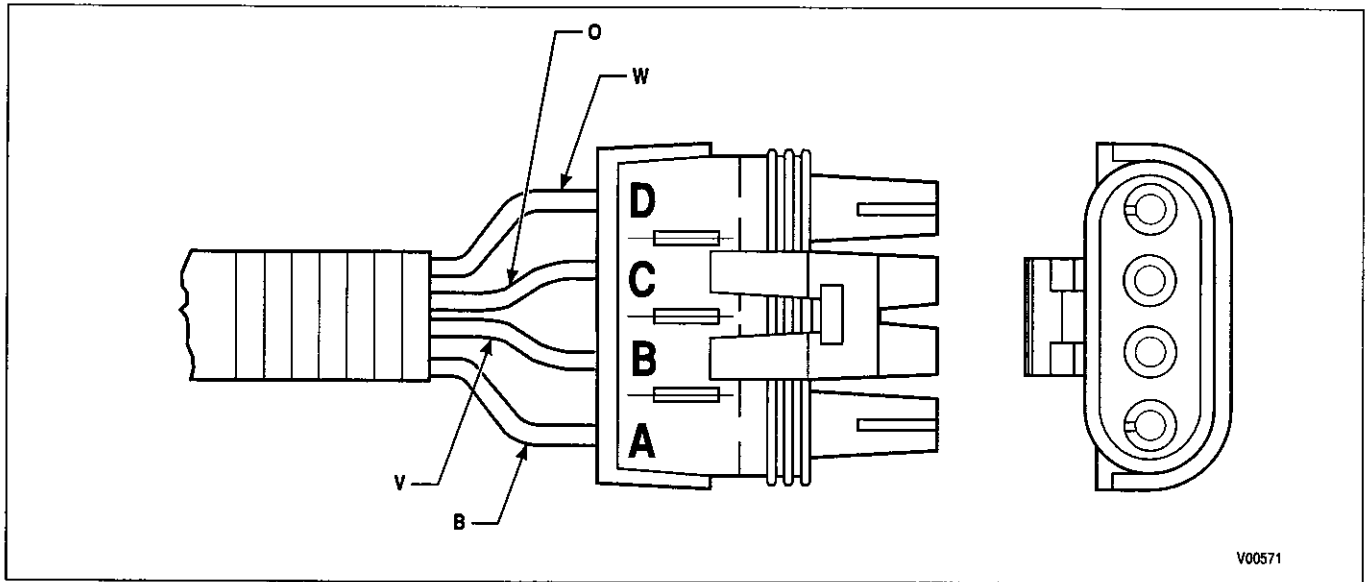

Figure D-24. Resistance Module Type 3 — Bendix E-10R Pedal

RESISTANCE MODULE TYPE 3

Terminal No.	Wire Color
A	Blue
B	Violet
C	Orange
D	White

APPENDIX D — WIRE/CONNECTOR CHART

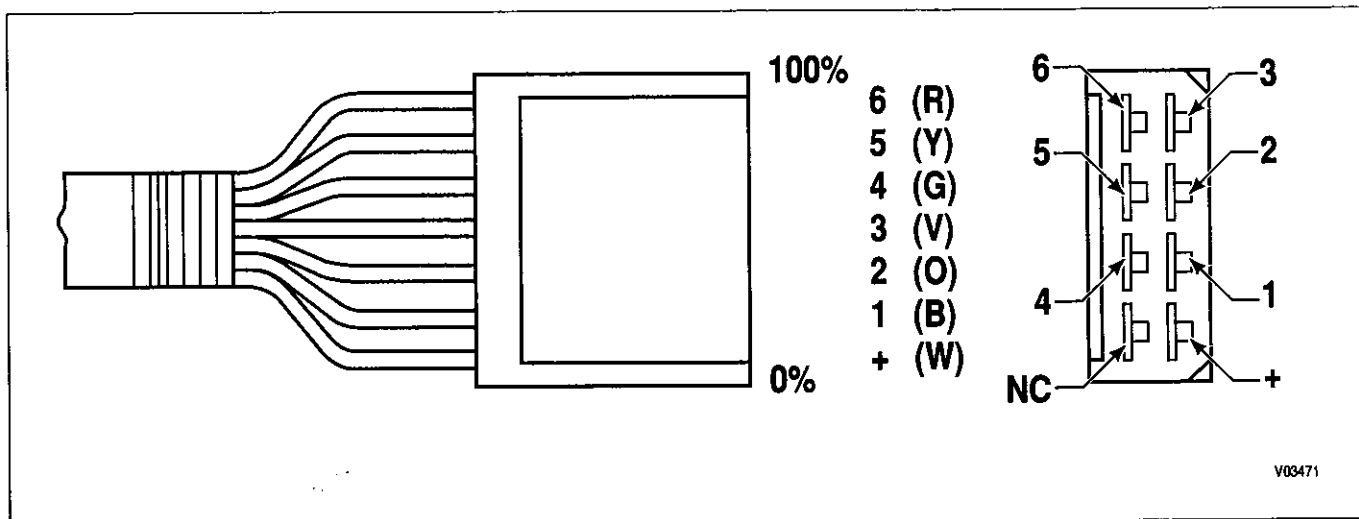

Figure D-25. Resistance Module Type 5 — Hand Lever

RESISTANCE MODULE TYPE 5

Terminal No.	Wire Color
+	White
1	Blue
2	Orange
3	Violet
4	Green
5	Yellow
6	Red

APPENDIX D — WIRE/CONNECTOR CHART

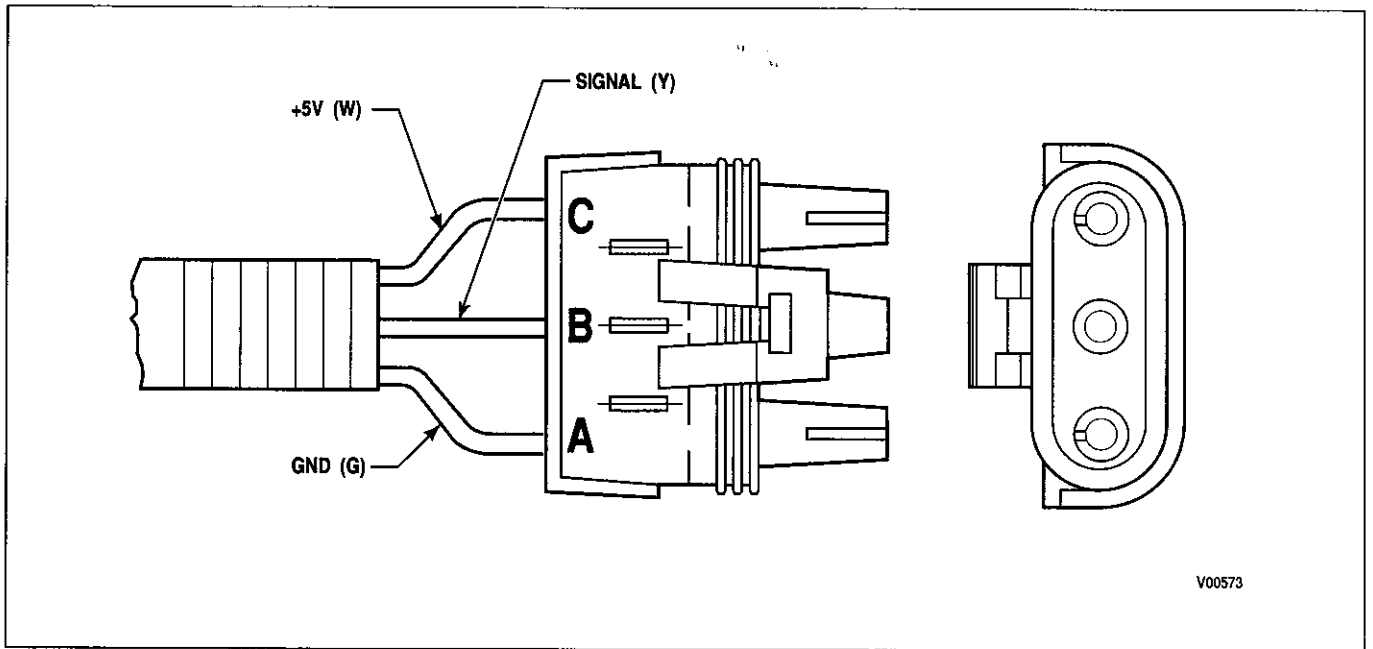

Figure D-26. Resistance Module Type 7 — Dedicated Pedal

RESISTANCE MODULE TYPE 7

Terminal No.	Wire Color
A	Green
B	Yellow
C	White

APPENDIX D — WIRE/CONNECTOR CHART

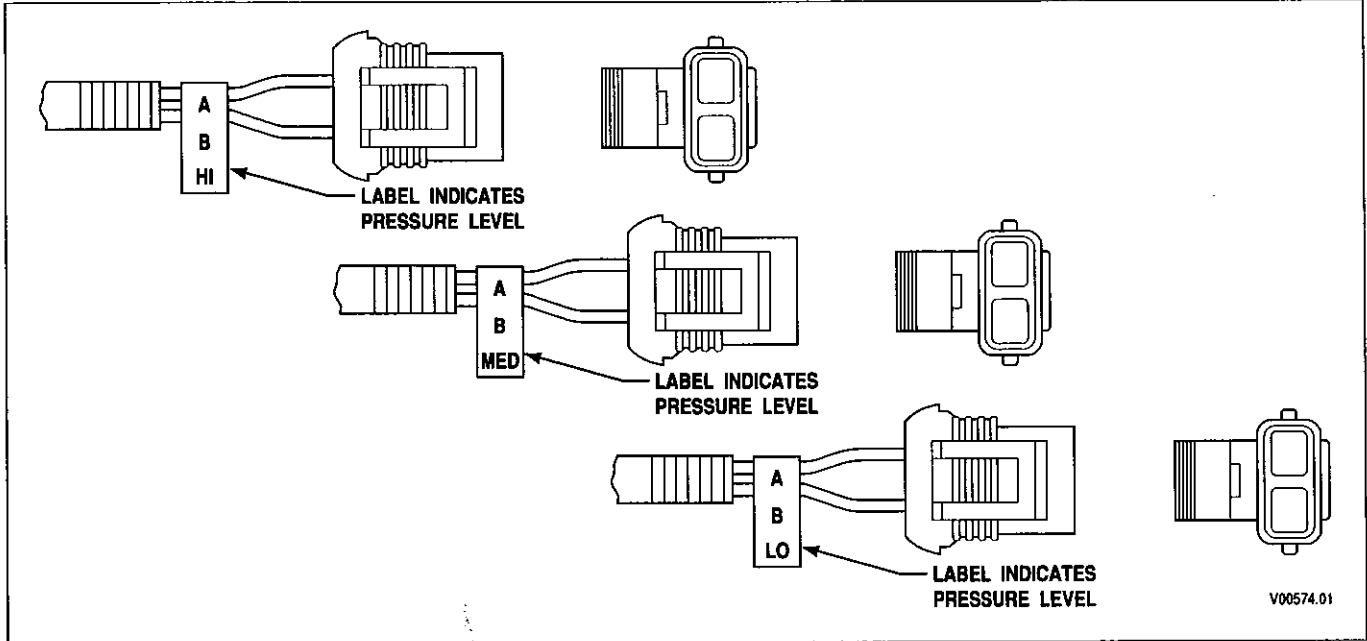

Figure D-27. Resistance Module Type 8 — Three Pressure Switch

RESISTANCE MODULE TYPE 8

LOW PRESSURE

Terminal No.	Wire Color
A	White
B	Blue

MEDIUM PRESSURE

Terminal No.	Wire Color
A	White
B	Orange

HIGH PRESSURE

Terminal No.	Wire Color
A	White
B	Violet

APPENDIX D — WIRE/CONNECTOR CHART

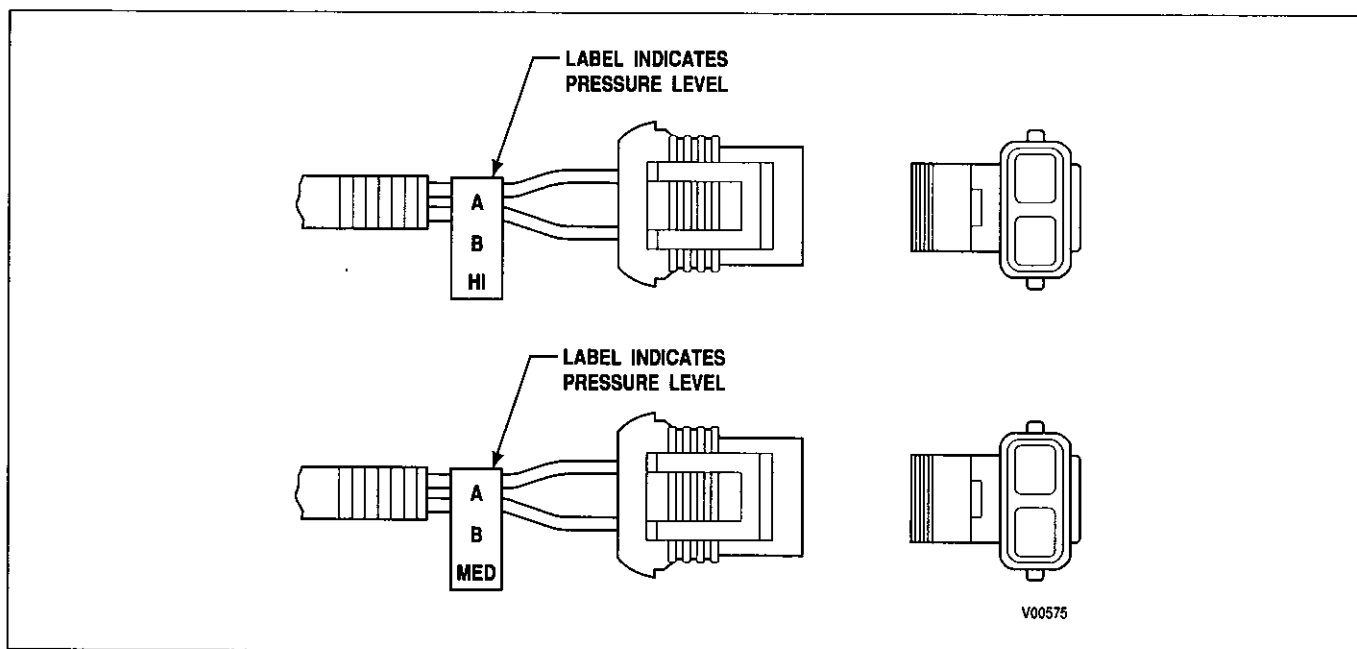

Figure D-28. Resistance Module Type 9 — Two Pressure Switch

RESISTANCE MODULE TYPE 9

MEDIUM PRESSURE

Terminal No.	Wire Color
A	White
B	Orange

HIGH PRESSURE

Terminal No.	Wire Color
A	White
B	Violet

APPENDIX D — WIRE/CONNECTOR CHART

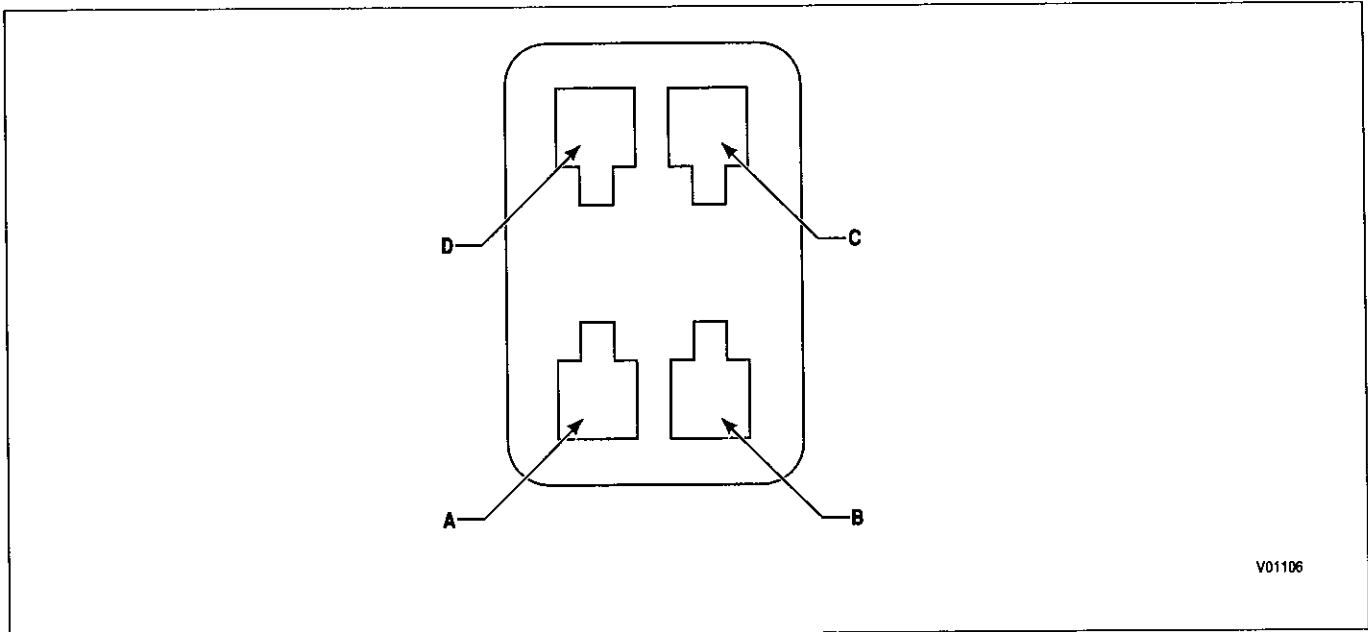

V01106

Figure D-29. Oil Level Sensor Plug

OIL LEVEL SENSOR CONNECTOR

Terminal No.	Color	Wire No.	Description	Termination Point(s) 31-Way Feedthrough Harness Connector
A	Blue	165	Oil Level Sensor Input	Y
B	Green	135	Analog Ground	N
C				
D	Pink	124	Sensor Power	D

APPENDIX D — WIRE/CONNECTOR CHART

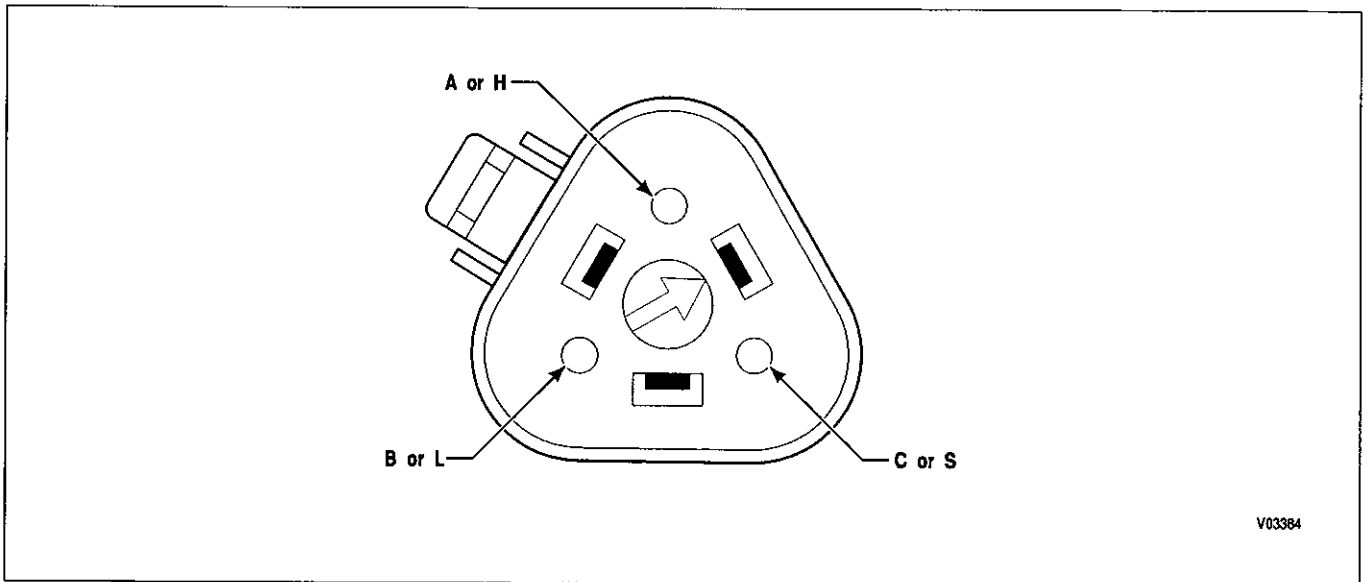

V03384

Figure D-30. J1939 Interface Connector

J1939 INTERFACE CONNECTOR

Terminal No.	Color	Wire No.	Description	Termination Point(s)
A or H	Pink	183-S13	J1939 Controller, Hi	ECU-S13
B or L	Gray	184-S29	J1939 Controller, Lo	ECU-S29
C or S	Green	182-S12	J1939 Shield	ECU-S12

APPENDIX D — WIRE/CONNECTOR CHART

NOTES

APPENDIX E — CONNECTOR PART NUMBERS, TERMINAL PART NUMBERS, TOOL PART NUMBERS, AND REPAIR INSTRUCTIONS

Contents	Page
List of Special Tools Required To Service WTEC III Wiring Harnesses	E-2
1-1. Delphi-Packard Micro Pack 100W Connectors (ECU, VIWV, VIWS, Shift Selectors)	E-5
1-2. Delphi-Packard Metri-Pack 150 Series Connectors — Pull-to-Seat (Speed Sensor; Accumulator Solenoid; 30-Way and 18-Way VIM)	E-9
1-3. Delphi-Packard Metri-Pack 150 Series Connectors — Push-to-Seat (Oil Level Sensor)	E-13
1-4. Delphi-Packard Metri-Pack 280 Series Connectors — Pull-to-Seat (Internal Harness Solenoid and C3 Pressure Switch)	E-17
1-5. Delphi-Packard Metri-Pack 280 Series Connectors — Push-to-Seat (DDR)	E-19
1-6. Delphi-Packard WeatherPack Connectors (TPS; 3-Way RMR Sensor; HD Retarder Temperature; 3-Way RMR Device (Dedicated Pedal))	E-21
1-7. Amp Products Connectors (8-Way RMR Device (Hand Lever))	E-25
1-8. Deutsch IPD/ECD Connectors (31-Way Bulkhead; 31-Way Feedthrough Harness; 16-Way Optional Sensor Harness; 6-Way Optional DDR; 9-Way Optional DDR)	E-27
1-9. ITT Cannon Connectors — Crimped (37-Way FMTV Bulkhead; 6-Way Transfer Case; 8-Way MD Retarder)	E-31
1-10. ITT Cannon Connectors — Soldered (2-Way HD Retarder)	E-35
1-11. Deutsch DT Series Connectors (3-Way J1939 Connector)	E-39
1-12. Repair of a Broken Wire with In-Line Butt Splice	E-41
1-13. List of WTEC III Connector Parts	E-43

NOTE: *Allison Transmission is providing for service of wiring harnesses and wiring harness components as follows:*

- Repair parts for the internal wiring harness and for wiring harness components attached to the shift selector will be available through the Allison Transmission Parts Distribution Center (PDC). Use the P/N from your appropriate parts catalog or from Appendix E in this manual. Allison Transmission is responsible for warranty on these parts.
- Repair parts for the external harnesses and external harness components must be obtained from St. Clair Technologies Inc. (SCTI). SCTI provides parts to any Allison customer or OEM and is responsible for warranty on these parts. SCTI recognizes ATD, manufacturers, and SCTI part numbers. SCTI provides a technical HELPLINE at 519-627-1673 (Wallaceburg). SCTI will have parts catalogs available. The SCTI addresses and phone numbers for parts outlets are:

St. Clair Technologies, Inc.
 1050 Old Glass Road
 Wallaceburg, Ontario, Canada, N8A 3T2
 Phone: (519) 627-1673
 Fax: (519) 627-4227

St. Clair Technologies, Inc.
 1111 Mikesell Street
 Charlotte, Michigan 48813
 Phone: (517) 541-8166
 Fax: (517) 541-8167

St. Clair Technologies, Inc.
 c/o Mequilas Tetakawi
 Carr. Internacional KM 1969
 Guadalajara – Nogales, KM2
 Empalme, Sonora, Mexico
 Phone: 011-52-622-34661
 Fax: 011-52-622-34662

APPENDIX E — CONNECTOR PART NUMBERS, TERMINAL PART NUMBERS, TOOL PART NUMBERS, AND REPAIR INSTRUCTIONS

- The Allison Transmission PDC will stock a WTEC III external harness repair kit, P/N 29532362, as an interim parts source for some external harness repair parts. SCTI will have a more complete stock and should be considered the prime source for external harness repair parts.

List Of Special Tools Required To Service WTEC III Wiring Harnesses

Tool Number	Tool Type	Paragraph Reference
23046604	Splice, Sealed (14–16 AWG)	1–12
23046605	Splice, Sealed (18–22 AWG)	1–12
J 25070	Heat Gun	1–12
J 34182	Crimper 1	1–8, 1–9, 1–11
J 34513	Remover 1	1–8
J 35123	Crimper (Alternate)	1–2
J 35606	Crimper (Alternate)	1–6
J 35615	Wire Stripper 1	1–12
J 35689-A	Remover	1–2
J 38125-10	Remover	1–6
J 38125-13	Remover	1–4, 1–5, 1–7
J 38125-6	Crimper	1–5, 1–6
J 38125-7	Crimper	1–2, 1–3, 1–5, 1–7
J 38125-8	Crimper	1–12
J 38582-3	Remover	1–8
J 38852	Crimper (Alternate)	1–6
J 39227	Remover	1–1
J 39841	Terminal Remover/Installer (MD Retarder)	1–9
J 39842	Terminal Remover/Installer (MD 3070 T-Case)	1–9
J 41193	Connector Repair Kit (FMTV)	1–9
J 41193-1	Guide Pin	1–9
J 41193-2	Insertion Tool	1–9
J 41193-3	Terminal Remover	1–9
J 41194	Extractor/Inserter	1–8
J 42215	Crimper	1–1
None	50–70 Percent Tin Resin Core Solder	1–10
None	Pen-Type Soldering Iron (Max OD = 3.175 mm)	1–10
None	Desoldering Braid	1–10

APPENDIX E — CONNECTOR PART NUMBERS, TERMINAL PART NUMBERS, TOOL PART NUMBERS, AND REPAIR INSTRUCTIONS

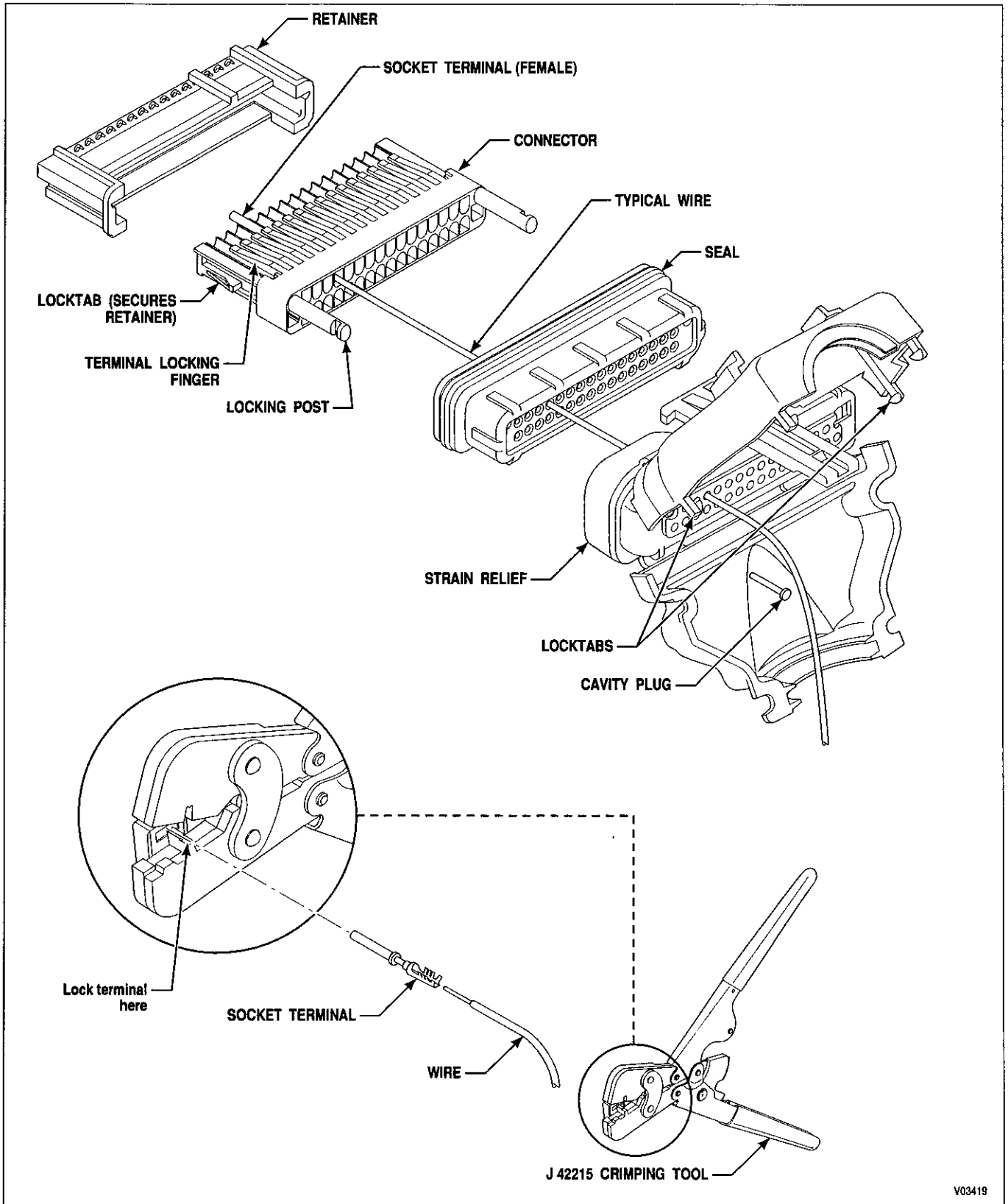

Figure E-1A. Delphi-Packard Micro Pack Connector (ECU)

APPENDIX E — CONNECTOR PART NUMBERS, TERMINAL PART NUMBERS, TOOL PART NUMBERS, AND REPAIR INSTRUCTIONS

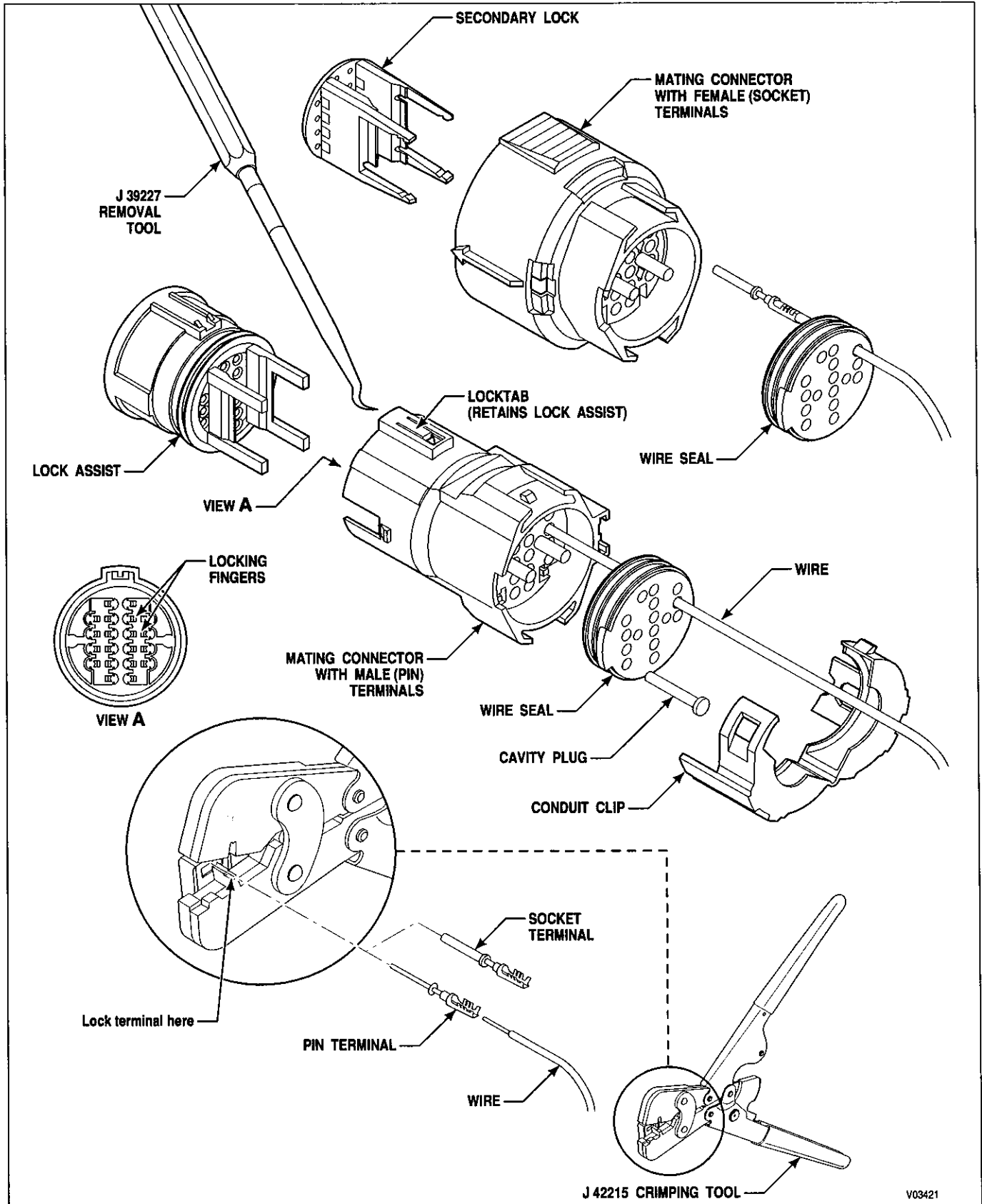

Figure E-1B. Delphi-Packard Micro Pack Connector (VIWV, VIWS, Shift Selector)

APPENDIX E — CONNECTOR PART NUMBERS, TERMINAL PART NUMBERS, TOOL PART NUMBERS, AND REPAIR INSTRUCTIONS

1-1. DELPHI-PACKARD MICRO PACK 100W CONNECTORS (ECU, VIWV, VIWS, SHIFT SELECTORS)

A. Connector/Terminal Repairs

Crimping Tool	J 42215
Remover Tool	J 39227

Use	Description	Manufacturers P/N
Electronic Control Unit (Harness)	Strain Relief, 32-Way Black	12191001 *
	Seal, 32-Way	15305333 *
	Cavity Plug	12129557 *
	Connector	15305371
	Retainer, Black	12129021 *
	Terminal, Socket	12084912 *
	CPA (Connector Position Assurance)	12177289 *
	Strain Relief, 32-Way Gray	12191002 *
	Retainer, Gray	12129022 *
	Strain Relief, 32-Way Blue	12191003 *
VIWV and VIWS (Harness)	Retainer, Blue	12129023 *
	Connector, Gray	12160542
VIWV Only	Wire Seal, Green	12110693
	Lock Assist, Blue	12191177
	Terminal, Pin	12160551
	Cavity Plug	12129557 *
	Conduit Clip, Black	12176394
VIWS Only	Lock Assist, White	12191178
Shift Selector (Harness)	Connector, Gray	12160280 *
	Wire Seal, Gray	15304882 *
	Secondary Lock, Green	12160494 *
	Terminal, Socket	12084912 *
Shift Selector (Device) (Kit P/N 29530475)	Connector, Gray	12160542
	Wire Seal, Green	12110693
	Lock Assist/Seal, Green	12191176
VIWV and VIWS (Device)	Conduit Clip, Black	12176394 *
	Connector, Gray	12160280
VIWV Only	Wire Seal, Gray	15304882
	Secondary Lock, Blue	12191172
VIWS Only	Terminal, Socket	12084912
	Secondary Lock, White	12191173

* These parts are contained in Allison Kit P/N 29532362.

APPENDIX E — CONNECTOR PART NUMBERS, TERMINAL PART NUMBERS, TOOL PART NUMBERS, AND REPAIR INSTRUCTIONS**B. Terminal Removal**

1. ECU Harness Connectors (*Figure E-1A*)
 - a. Use a small-bladed screwdriver to gently release the locktabs at the splitline of the strain relief.
 - b. Spread the strain relief open.
 - c. Remove the retainer from the connector by using a small-bladed screwdriver to depress the locktabs on the side of the connector.
 - d. Remove a selected terminal by pushing forward on the wire or by lifting the locking finger and pulling the wire and terminal rearward out of the connector.
2. VIWV and VIWS Harness Connectors and Shift Selector (Device) Connectors (*Figure E-1B*)
 - a. Lift locktab on the side of the connector and remove the lock assist.
 - b. Open the conduit clip on the back of the connector after lifting locktabs on each side and sliding clip back to release it from connector.
 - c. Use the J 39227 tool to release the locking finger inside the connector and pull the terminal/wire out the rear of the connector.
3. VIWV and VIWS (Device) Connectors and Shift Selector Harness Connectors (*Figure E-1B*)
 - a. Carefully insert a small screwdriver blade between the connector body and the secondary lock. Twist/pry to remove the secondary lock from the connector body.
 - b. Open the conduit clip on the back of the connector after lifting locktabs on each side and sliding clip back to release it from connector.
 - c. Use the J 39227 tool to release the locking finger inside the connector and pull the terminal/wire out the rear of the connector.

C. Terminal Crimping

1. Carefully strip insulation to leave $5.0 \text{ mm} \pm 0.5 \text{ mm}$ (0.20 ± 0.02 inch) of bare wire showing.
2. Insert the new terminal to be crimped in the J 42215 crimping tool. There is a spring-loaded terminal positioner at the front of the tool to hold the terminal in place. Squeeze the crimper handles for a few clicks to start the crimping process but leave room to insert the wire end.
3. Insert the bare wire end into the terminal. Squeeze the crimper handles to complete the crimping process and until the crimper handles open when released to remove the terminal/wire from the tool.
4. Complete terminal installation for VIW and Shift Selector Connectors as follows: (*Figure E-1B*)
 - a. Insert the wire seal in the back of the connector.
 - b. Push the terminal/wire assembly through the proper hole in the back of the wire seal. Push the wire in until the terminal clicks into position. Gently pull rearward on the wire to be sure that the terminal is fully seated. Install cavity plugs as needed.
 - c. Install the lock assist or secondary lock into the connector body.
 - d. Close the conduit clip around the conduit and lock the clip into the rear of the connector body.

APPENDIX E — CONNECTOR PART NUMBERS, TERMINAL PART NUMBERS, TOOL PART NUMBERS, AND REPAIR INSTRUCTIONS

C. Terminal Crimping (*cont'd*)

5. Complete terminal installation of the ECU Connectors as follows: (*Figure E-1A*)
 - a. Align the locking posts on the connector with the seal and push the locking posts through the seal into the mating holes in the strain relief (if the connector was removed from the strain relief).
 - b. Push the terminal/wire assembly through the proper hole in the back of the seal. Push the wire in until the terminal clicks into position.

NOTE: *All terminals must be properly positioned to install the retainer in Step (5c).*

- c. Install the retainer on the connector body to lock the terminals in position. Pull rearward on the wire to be sure that the terminal is fully seated. Install cavity plugs as needed.
- d. Position the conduit inside the strain relief and snap the strain relief halves together.

APPENDIX E — CONNECTOR PART NUMBERS, TERMINAL PART NUMBERS, TOOL PART NUMBERS, AND REPAIR INSTRUCTIONS

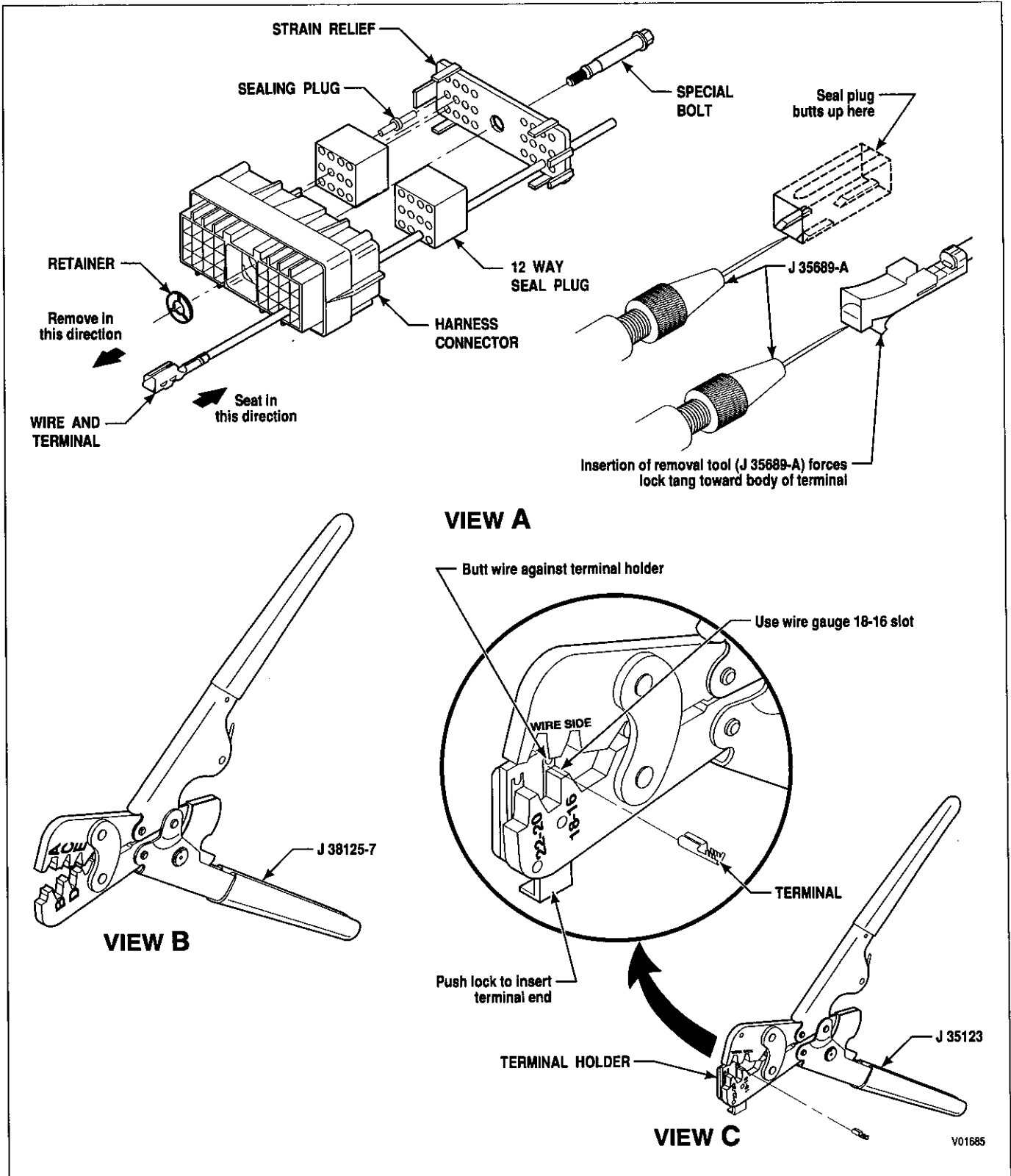

Figure E-2. Delphi-Packard Metri-Pack 150 Series Connectors — Pull-to-Seat (Speed Sensor; Accumulator Solenoid; Retarder Solenoid, TID 2; 30-Way and 18-Way VIM)

APPENDIX E — CONNECTOR PART NUMBERS, TERMINAL PART NUMBERS, TOOL PART NUMBERS, AND REPAIR INSTRUCTIONS

1-2. DELPHI-PACKARD METRI-PACK 150 SERIES CONNECTORS — PULL-TO-SEAT (SPEED SENSOR; ACCUMULATOR SOLENOID; 30-WAY AND 18-WAY VIM)

A. Connector/Terminal Repairs

Crimping Tool	J 38125-7
Wire Crimp	Anvil "E"
Insulation Crimp	Anvil "C"
Alternate Crimping Tool	J 35123
Remover Tool	J 35689-A

Use	Description	Manufacturers P/N	
Turbine Speed (Nt) Sensor (MD/B 300/B 400)	Connector	12162723	
	Terminal	12110236	
Turbine Speed (Nt) Sensor (HD/B 500)	Connector	12162193	
	Terminal	12103881	
Engine/Output (All Models) (Ne/No) Speed Sensor	Connector	12162197	
	Terminal	12103881	
Accumulator (N Solenoid) And Retarder (H Solenoid For TID 2)	Connector	12162197	
	Terminal	12103881	
Vehicle Interface Module (VIM)	Connector (VIM)		
	Connector Body	12040920	
	9-Way Seal (x2)	12040936	
	18-Way Strain Relief	12110545	
	Special Bolt	12129426	
	Bolt Retainer	12034236	
	Sealing Plug	12034413	
	Terminal	12103881	
	Vehicle Interface Module (Vehicle)	Connector (OEM)	
		Connector Body	12034397
15-Way Seal (x2)		12040879	
30-Way Strain Relief		12110546	
Special Bolt		12129426	
Bolt Retainer		12034236	
Sealing Plug		12034413	
Terminal		12103881	

B. Terminal Removal

NOTE: *Do not solder crimps.*

1. Insert needle end of terminal remover J 35689-A into the small notch between the connector and the terminal to be removed (Figure E-2, View A). Push the lock tang toward the terminal.
2. Push the wire and terminal out of the connector (this is a "pull-to-seat" terminal).

APPENDIX E — CONNECTOR PART NUMBERS, TERMINAL PART NUMBERS, TOOL PART NUMBERS, AND REPAIR INSTRUCTIONS

B. Terminal Removal (*cont'd*)

3. Pull terminal as far as necessary from the connector. This will be limited by the number of other wires inserted into the connector and by the distance between the back side of the connector and the beginning of the harness covering.
4. If terminal is to be replaced, cut the terminal between the core and insulation crimp to minimize wire loss.

C. Terminal Crimping — VIM And Speed Sensor Terminals (Standard Crimping Tool)

1. If a spare wire is used, the wire should be pushed through the proper hole in the strain relief (if used), through the wire seal, and out the other side of the connector before stripping.
2. Carefully strip insulation $4.5 \text{ mm} \pm 0.5 \text{ mm}$ (0.18 ± 0.02 inch). Unless insulation crimp is overtight, Automatic Wire Stripper J 35615 will remove insulation and crimp from old terminal without damaging wire.
3. Place core crimp portion of terminal on bed of anvil "E" and squeeze crimper enough to keep terminal from dropping (Figure E-2, View B).
4. Position wire core in terminal and squeeze crimper tool to complete the core crimp. **Be sure to orient the terminal so that it is properly aligned with the terminal cavity in the connector.** The terminal should be positioned so that the lock tang is on the side of the cavity which has the notch in the middle (for the remover tool).
5. Position insulation crimp of terminal on anvil "C" so that the entire insulation crimp area and a portion of the terminal between the core and insulation crimp areas are supported by the anvil. Complete the insulation crimp.
6. Be sure lock tang is lifted to allow proper reseating of the terminal.
7. Pull on the wire to pull the terminal completely into the cavity. (A click will be heard and the terminal should stay in place if the wire is pushed.)

D. Terminal Crimping Using Alternate Tool J 35123

1. If a spare wire is used, the wire should be pushed through the proper hole in the strain relief (if used) and the wire seal, and out the other side of the connector prior to stripping.
2. Insert remover tool in front side of connector to release locktab and push terminal out front of connector. Pull the terminal and wire out the front of the connector to complete Steps (3) through (7).
3. Push open the terminal holder on the crimper tool J 35123 and insert a terminal into the opening marked 18-16 (Figure E-2, View C) so that the crimp ends point up. Release the terminal holder.
4. Slightly close the crimping tool (close until one click is heard) but do not start to crimp the terminal. Place the terminal on the wire so it is in the same position as it will be when pulled back into the connector. The terminal should be positioned so that the lock tang is on the side of the cavity which has the notch in the middle (for the remover tool).
5. Insert the wire into the terminal until the wire contacts the holder. (By doing this, the core and insulation should be properly positioned for the core and insulation crimp wings.)
6. Squeeze the crimper fully until it opens when released.

APPENDIX E — CONNECTOR PART NUMBERS, TERMINAL PART NUMBERS, TOOL PART NUMBERS, AND REPAIR INSTRUCTIONS

D. Terminal Crimping Using Alternate Tool J 35123 (*cont'd*)

7. Open the terminal holder and remove the wire and terminal from the crimping tool.
8. Pull on the terminal to assure a tight crimp.
9. Be sure lock tang is lifted to allow proper reseating of the terminal.
10. Pull on the wire to pull the terminal completely into the cavity. (A click will be heard and the terminal should stay in place if the wire is pushed.)

APPENDIX E — CONNECTOR PART NUMBERS, TERMINAL PART NUMBERS, TOOL PART NUMBERS, AND REPAIR INSTRUCTIONS

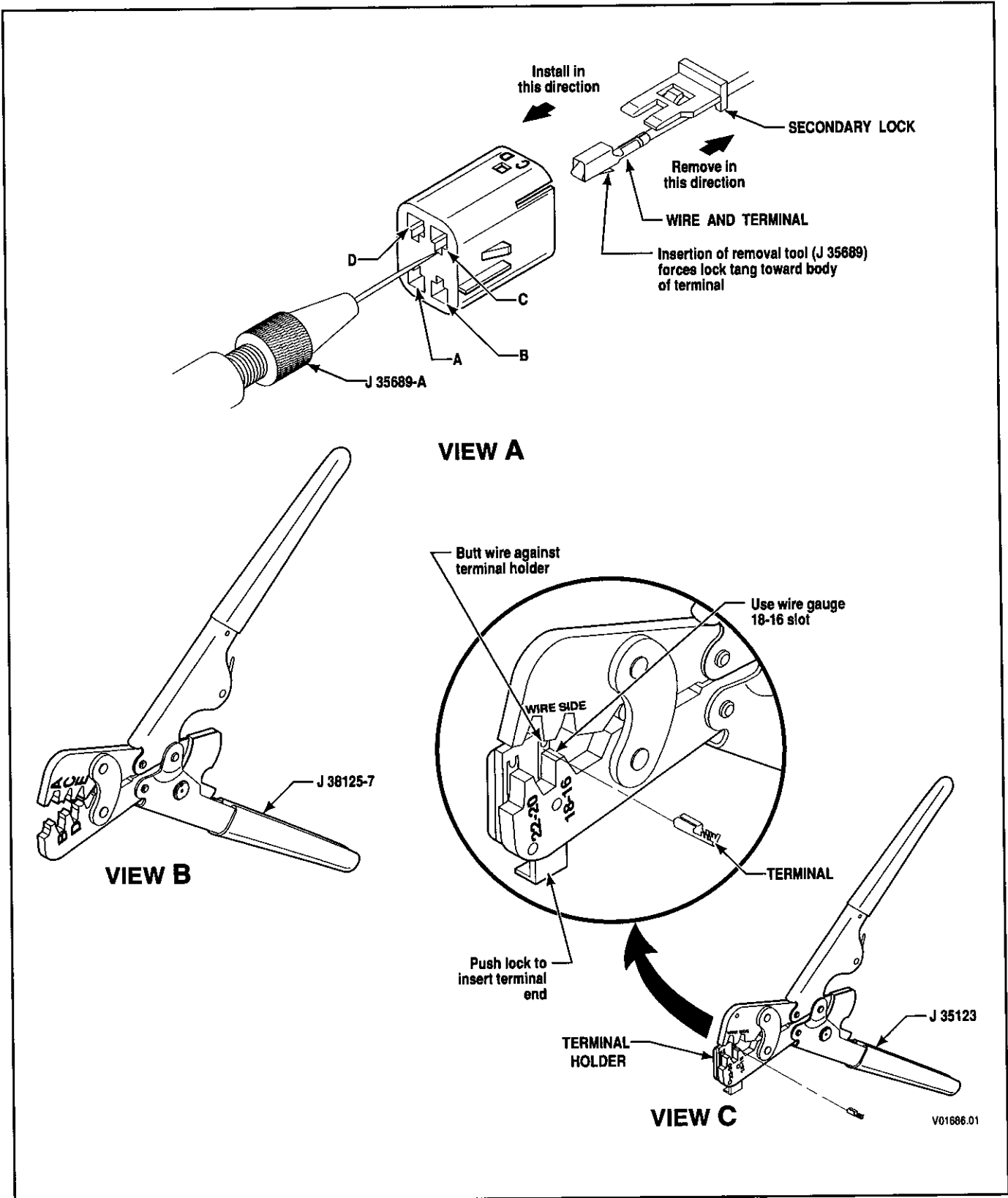

Figure E-3. Delphi-Packard Metri-Pack 150 Series Connectors — Push-to-Seat (Oil Level Sensor)

APPENDIX E — CONNECTOR PART NUMBERS, TERMINAL PART NUMBERS, TOOL PART NUMBERS, AND REPAIR INSTRUCTIONS

1-3. DELPHI-PACKARD METRI-PACK 150 SERIES CONNECTORS — PUSH-TO-SEAT (OIL LEVEL SENSOR)

A. Connector/Terminal Repairs

Crimping Tool	J 38125
Wire Crimp	Anvil "E"
Insulation Crimp	Anvil "C"
Alternate Crimping Tool	J 35123
Remover Tool	J 35689

Use	Description	Manufacturers P/N
Oil Level Sensor	4-Pin Plug	12047786
	Terminal (Pin)	12047581
	Secondary Lock	12047787
	4-Pin Receptacle	12047785
	Terminal (Socket)	12047767
	Secondary Lock	12047664

B. Terminal Removal

NOTE: *Do not solder crimps.*

1. Remove the secondary lock.
2. Insert needle end of terminal remover J 35689-A into the small notch between the connector and the terminal to be removed (Figure E-3, View A). Push the lock tang toward the terminal.
3. Pull the wire and terminal out the rear of the connector (this is a "push-to-seat" terminal).
4. Pull terminal as far as necessary from the connector. This will be limited by the number of other wires inserted into the connector and by the distance between the back side of the connector and the beginning of the harness covering.
5. If terminal is to be replaced, cut the terminal between the core and insulation crimp to minimize wire loss.

C. Terminal Crimping

1. Carefully strip insulation $4.5 \text{ mm} \pm 0.5 \text{ mm}$ (0.18 ± 0.02 inch). Unless insulation crimp is overtight, Automatic Wire Stripper J 35615 will remove insulation and crimp from old terminal without damaging wire.
2. Place core crimp portion of terminal on bed of anvil "E" and squeeze crimper enough to keep terminal from dropping (Figure E-3, View B).
3. Position wire core in terminal and squeeze crimper tool to complete the core crimp. **Be sure to orient the terminal so that it is properly aligned with the terminal cavity in the connector.** The terminal should be positioned so that the lock tang is on the side of the cavity which has the notch in the middle (for the remover tool).

APPENDIX E — CONNECTOR PART NUMBERS, TERMINAL PART NUMBERS, TOOL PART NUMBERS, AND REPAIR INSTRUCTIONS**C. Terminal Crimping (*cont'd*)**

4. Position insulation crimp of terminal on anvil "C" so that the entire insulation crimp area and a portion of the terminal between the core and insulation crimp areas are supported by the anvil. Complete the insulation crimp.
5. Be sure lock tang is lifted to allow proper reseating of the terminal.
6. Push on the wire until the terminal is completely into the cavity. (A click will be heard and the terminal should stay in place when the wire is lightly pulled.)

D. Terminal Crimping Using Alternate Tool J 35123

1. Insert remover tool in front side of connector to release locktab and pull terminal out rear of connector. Pull the terminal and wire out the rear of the connector to complete Steps (3) through (7).
2. Push open the terminal holder on the crimper tool J 35123 and insert a terminal into the opening marked 18-16 (Figure E-3, View C) so that the crimp ends point up. Release the terminal holder.
3. Slightly close the crimping tool (close until one click is heard) but do not start to crimp the terminal. Place the terminal on the wire so it is in the same position as it will be when pulled back into the connector. The terminal should be positioned so that the lock tang is on the side of the cavity which has the notch in the middle (for the remover tool).
4. Insert the wire into the terminal until the wire contacts the holder. (By doing this, the core and insulation should be properly positioned for the core and insulation crimp wings.)
5. Squeeze the crimper fully until it opens when released.
6. Open the terminal holder and remove the wire and terminal from the crimping tool.
7. Pull on the terminal to assure a tight crimp.
8. Be sure lock tang is lifted to allow proper reseating of the terminal.
9. Push on the wire until the terminal is completely into the cavity. (A click will be heard and the terminal should stay in place if the wire is lightly pulled.)

**APPENDIX E — CONNECTOR PART NUMBERS, TERMINAL PART
NUMBERS, TOOL PART NUMBERS, AND REPAIR INSTRUCTIONS**

NOTES

APPENDIX E — CONNECTOR PART NUMBERS, TERMINAL PART NUMBERS, TOOL PART NUMBERS, AND REPAIR INSTRUCTIONS

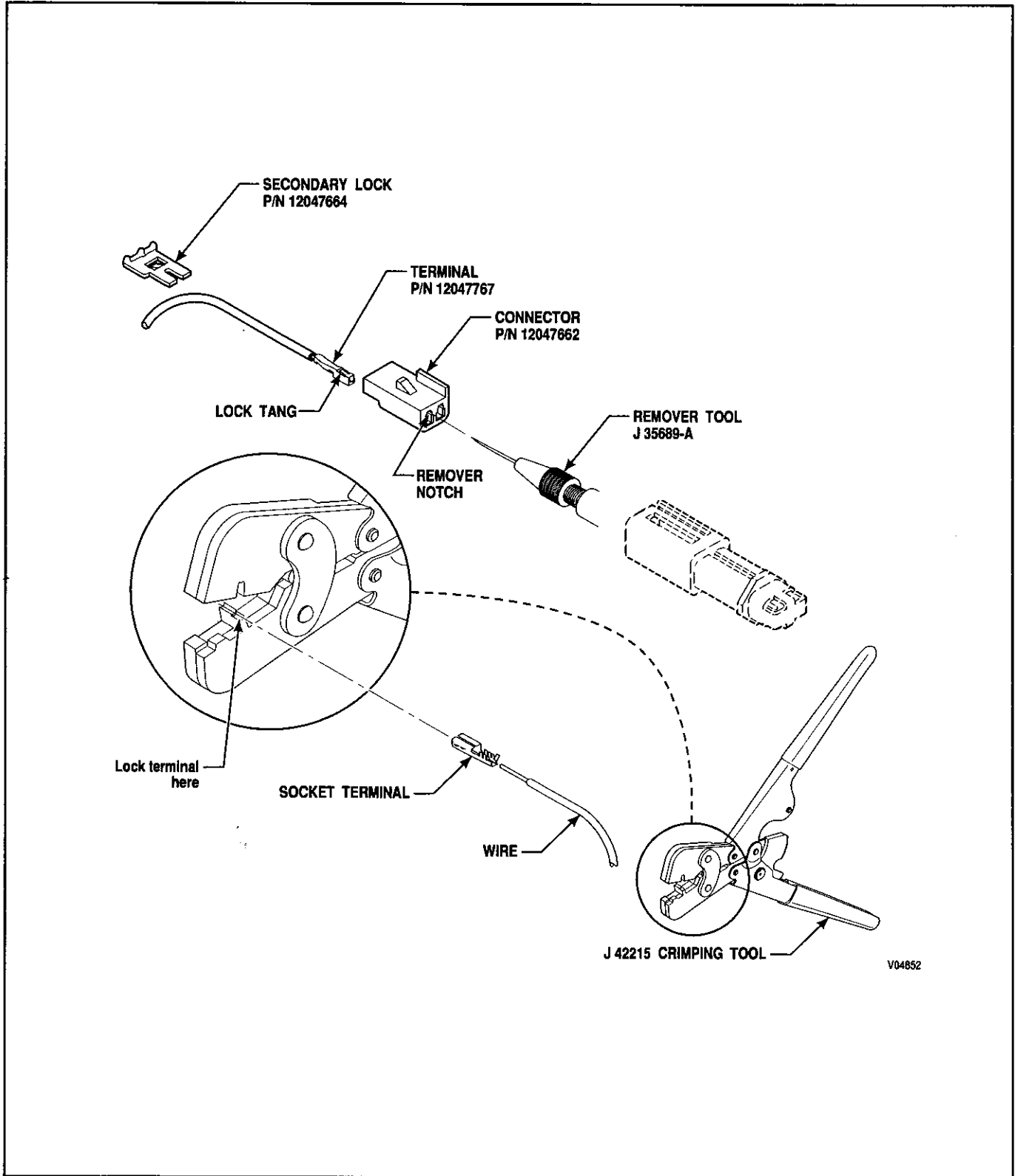

V04852

Figure E-4. Delphi-Packard Metri-Pack 150 Series Connector — Push-To-Seat (MD/HD/B TID 2 Sump Temperature Thermistor)

APPENDIX E — CONNECTOR PART NUMBERS, TERMINAL PART NUMBERS, TOOL PART NUMBERS, AND REPAIR INSTRUCTIONS

1-4. DELPHI-PACKARD METRI-PACK 150 SERIES CONNECTORS — PUSH-TO-SEAT (MD/HD/B TID 2 SUMP TEMPERATURE THERMISTOR)

A. Connector/Terminal Repairs:

Crimping Tool	J 42215 (with terminal positioner removed)
Remover Tool	J 35689-A

Use	Description	Manufacturers P/N
MD/HD/B, TransID 2	Sump Temperature Sensor	12129691
Sump Temperature Thermistor	Connector, Black	12047662
	Terminal	12047767
	Secondary Lock	12047664

B. Terminal Removal:

1. Remove the secondary lock from the connector.
2. Insert needle end of terminal remover J 35689-A into the small notch in the front of the connector cavity of the terminal to be removed (refer to Figure 7).
3. Push the lock tang toward the terminal.
4. Pull the wire and terminal out of the connector.
5. Cut the terminal between the core and insulation crimp to minimize wire loss.

C. Terminal Crimping:

1. Strip insulation approximately 4.5 mm (0.18 inch).
2. Remove the spring-loaded terminal positioner from the J 42215 crimping tool.
3. Insert the new terminal to be crimped in the J 42215 crimping tool. Squeeze the crimper handles a couple clicks to start the crimping process but leave room to insert the wire end.
4. Insert the bare wire end into the terminal. Squeeze the crimper handles to complete the crimping process and until the crimper handles open when released to remove the terminal/wire from the tool.
5. Be sure the lock tang is positioned to allow proper retention of the terminal in the connector.
6. Push the terminal completely into the cavity. (A click will be heard and the terminal should stay in place if the wire is pulled.)
7. Install the secondary lock in the connector.

APPENDIX E — CONNECTOR PART NUMBERS, TERMINAL PART NUMBERS, TOOL PART NUMBERS, AND REPAIR INSTRUCTIONS

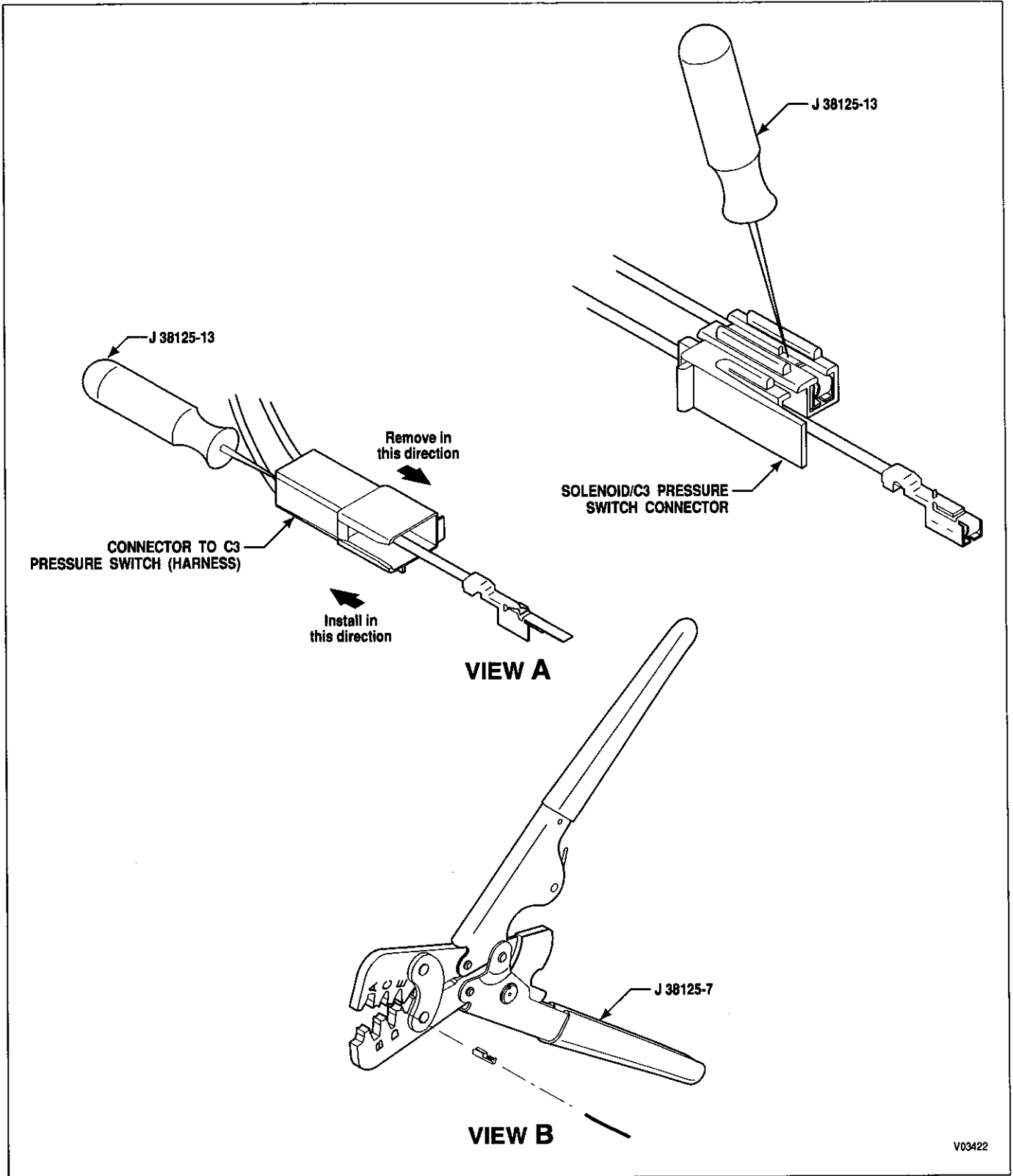

Figure E-5. Delphi-Packard Metri-Pack 280 Series Connectors — Pull-to-Seat (Internal Harness Solenoid and C3 Pressure Switch)

V03422

APPENDIX E — CONNECTOR PART NUMBERS, TERMINAL PART NUMBERS, TOOL PART NUMBERS, AND REPAIR INSTRUCTIONS

1-5. DELPHI-PACKARD METRI-PACK 280 SERIES CONNECTORS — PULL-TO-SEAT (INTERNAL HARNESS SOLENOID AND C3 PRESSURE SWITCH)

A. Connector/Terminal Repairs

Crimping Tool J 38125-7

NOTE: Crimping anvils will be listed following the terminal part numbers for the various connectors in this section. The anvil for the core crimp is always listed first.

Remover Tool J 38125-13

Use	Description	Manufacturers P/N
Solenoid/C3 Pressure Switch (Switch)	Connector	12092420
C3 Pressure Switch (Harness)	Connector	12110139
Solenoid/C3 Pressure Switch (Switch)	Terminal (Use crimping anvils "C" and "D")	12124639
C3 Pressure Switch (Harness)	Terminal (Use crimping anvils "C" and "D")	12066337
Solenoid (A, B, and G)	Terminal (2 Wire) B (Use crimping anvils "A" and "B")	12015243

B. Terminal Removal

1. Depress locktab on terminal (accessible in slot of connector) and push terminal out front of connector (Figure E-4, View A).
2. If replacing terminal, cut terminal between core and insulation crimp (to minimize wire loss).

C. Terminal Crimping

1. Carefully strip insulation $6.5 \text{ mm} \pm 0.5$ (0.26 ± 0.02 inch). Unless insulation crimp is overtight, Automatic Wire Stripper J 35615 will remove insulation and crimp from old terminal without damaging wire).
2. Place core crimp portion of terminal on bed of anvil indicated and squeeze crimper enough to hold terminal from dropping (Figure E-4, View B).
3. Position wire core in terminal and squeeze crimper tool to complete the core crimp. Be sure to orient the terminal so that it is properly aligned with the terminal cavity in the connector. (When crimping two wires in terminal P/N 12015243, strip and twist cores together before inserting into the terminal.)
4. Position insulation crimp of terminal on anvil indicated so that the entire insulation crimp area and a portion of the terminal between the core and insulation crimp areas are supported by the anvil. Complete the insulation crimp.
5. Slip the wire through the slot in the connector and pull to fully seat the terminal(s).

APPENDIX E — CONNECTOR PART NUMBERS, TERMINAL PART NUMBERS, TOOL PART NUMBERS, AND REPAIR INSTRUCTIONS

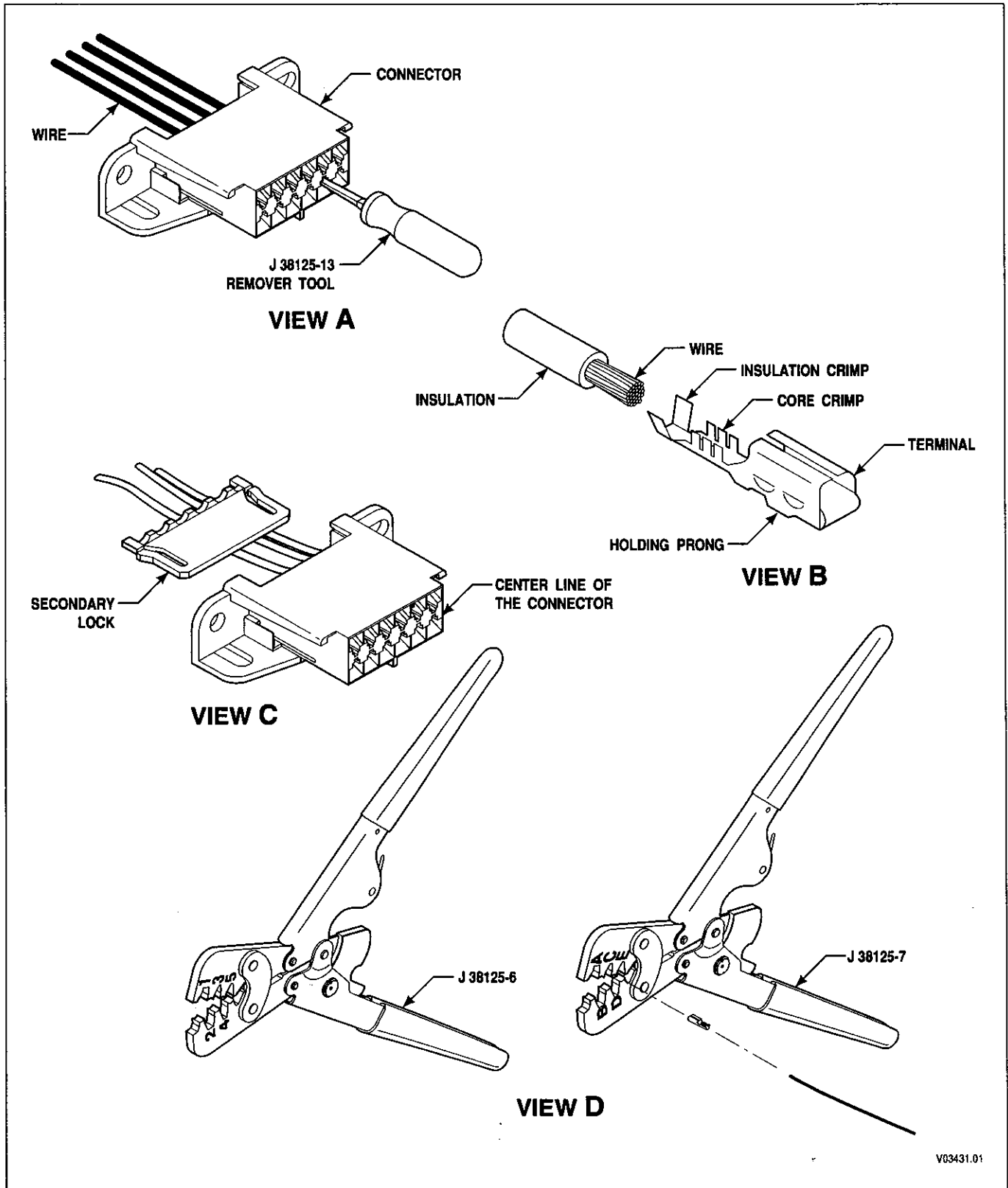

V03431.01

Figure E-6. Delphi-Packard Metri-Pack 280 Series Connectors — Push-to-Seat (DDR)

APPENDIX E — CONNECTOR PART NUMBERS, TERMINAL PART NUMBERS, TOOL PART NUMBERS, AND REPAIR INSTRUCTIONS

1-6. DELPHI-PACKARD METRI-PACK 280 SERIES CONNECTORS — PUSH-TO-SEAT (DDR)

A. Connector/Terminal Repairs

Crimping Tool	J 38125-6 and 7
Wire Crimp	Anvil "2"
Insulation Crimp	Anvil "A"
Remover Tool	J 38125-13

Use	Description	Manufacturers P/N
Diagnostic Connector	Connector	12048105
	Terminal	12034046
	Terminal (2-Wire)	12066214
	Secondary Lock	12020219
	Cover	12048107

B. Terminal Removal

1. Remove secondary lock from back of connector (Figure E-5, View C). (Use a small screwdriver or pick in the slots on each side of the connector.)
2. Insert remover tool J 38125-13 into open (front) end of connector at terminal to be serviced (Figure E-3, View A).
3. Push the lock tang of the terminal straight and pull wire and terminal out the back of connector.
4. If the terminal is to be replaced, cut terminal between core and insulation crimp (this minimizes wire length loss).

C. Terminal Crimping

1. Carefully strip insulation 6.0 ± 0.25 mm (0.24 ± 0.01 inch).
2. Insert terminal into crimping tool (Figure E-5, View D), anvil "2."
3. Slightly close crimping tool to hold the terminal steady.
4. Align the terminal with its position in the connector and insert wire so that the stripped portion of the wire is in the core crimping area and the insulated portion of the wire is in the insulation crimping area (Figure E-5, View B).
5. Crimp the stripped section of the wire (Figure E-5, View D).
6. Remove the terminal from the crimping tool.
7. Use a pair of needle nose pliers, if necessary, to start the bend on the insulation crimp wings (Figure E-5, View D).
8. Crimp the insulated section of wire using anvil "A" of the crimpers shown (Figure E-5, View D).
9. Remove the terminal from the crimping tool.
10. Tug on terminal to make sure the crimp is tight.
11. Insert terminal into connector with the locktab toward the center line of the connector (Figure E-5, View C).
12. The terminal should "click" into place and you should not be able to pull the terminal out by hand.
13. Reinstall the secondary lock.

APPENDIX E — CONNECTOR PART NUMBERS, TERMINAL PART NUMBERS, TOOL PART NUMBERS, AND REPAIR INSTRUCTIONS

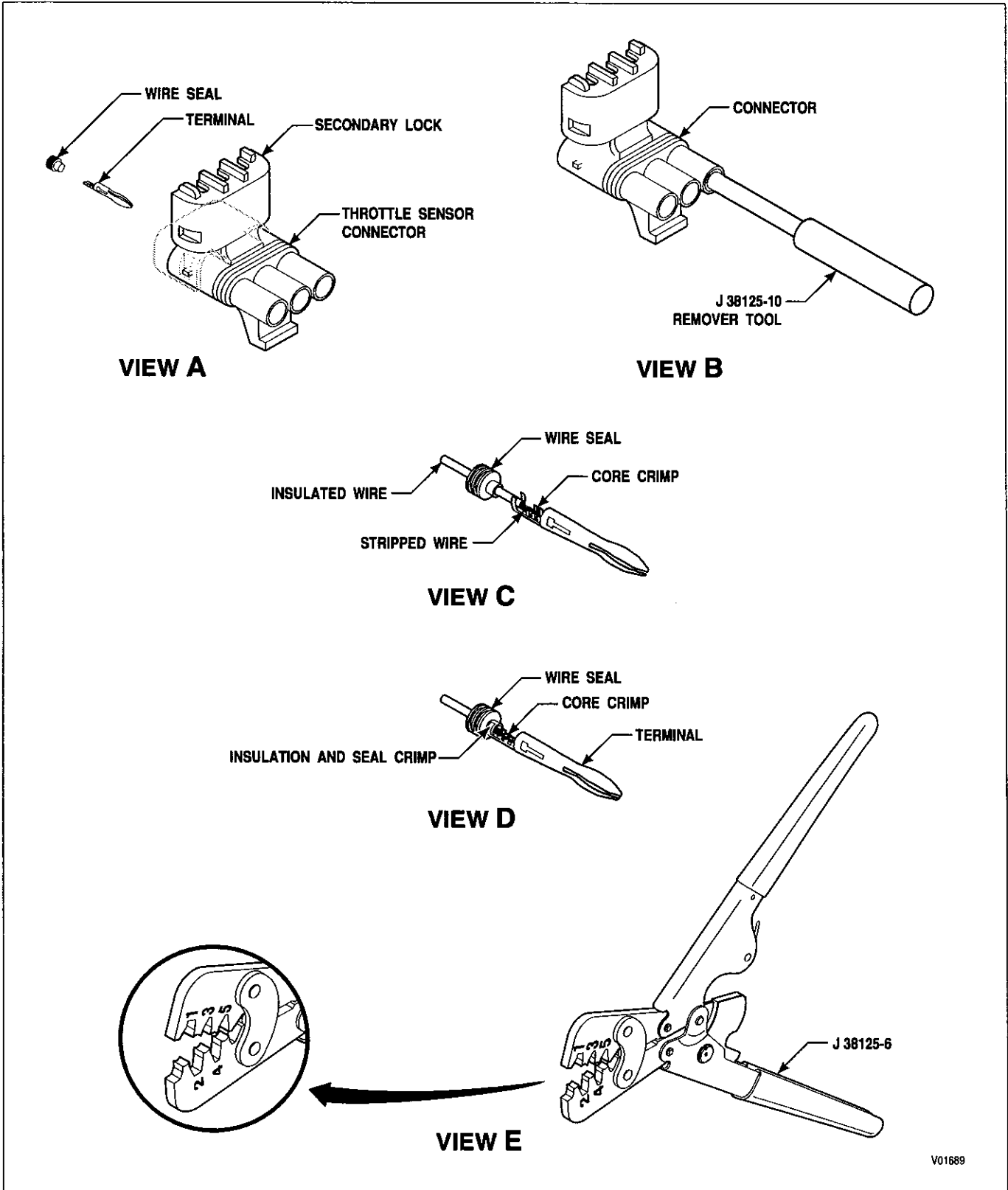

Figure E-7. Delphi-Packard WeatherPack Connectors (TPS; 3-Way RMR Sensor; HD Pre-TID And TID 1 Retarder Temperature; 4-Way RMR Device, Type 3; 3-Way RMR Device (Dedicated Pedal))

V01689

APPENDIX E — CONNECTOR PART NUMBERS, TERMINAL PART NUMBERS, TOOL PART NUMBERS, AND REPAIR INSTRUCTIONS

1-7. DELPHI-PACKARD WEATHERPACK CONNECTORS (TPS; 3-WAY RMR SENSOR; HD RETARDER TEMPERATURE; 3-WAY RMR DEVICE (DEDICATED PEDAL))

A. Connector/Terminal Repairs

Crimping Tool	J 38125-6
Wire Crimp	Anvil "2"
Insulation Crimp	Anvil "5"
Alternate Crimping Tool	J 35606 or J 38852
Remover Tool	J 38125-10

Use	Description	Manufacturers P/N
Throttle Position Position (TPS)	Connector	12015793
	Terminal	12089040
	Wire Seal	12089444
RMR Device	Connector	12015795
	Terminal	12089040
	Wire Seal	12089444
Retarder Temperature Sensor	Connector	12010973
	Terminal (Socket)	12089188
	Wire Seal	12089444

B. Terminal Removal

1. Unlatch and open the secondary lock on the connector (Figure E-6, View A).
2. On the front of the connector, insert remover tool J 38125-10 over the terminal. Push the tool over the terminal and pull the terminal out of the back end of the connector (Figure E-6, View B).
3. If terminal is to be replaced, cut terminal between core and insulation crimp (this minimizes wire loss).

NOTE: *Two special tools are available for this operation: tool J 38125-6 (Paragraph C); tool J 35606 or J 38852 (Paragraph D).*

C. Terminal Crimping Using Crimping Tool J 38125-6

1. Place the wire seal onto the wire before stripping the wire (Figure E-6, View C).
2. Strip wire to 6.0 ± 0.25 mm (0.24 ± 0.01 inch).
3. Place terminal onto crimping tool J 38125-6 (Figure E-6, View E), anvil "2."
4. Slightly close crimping tool to hold terminal steady.
5. Insert wire so that the stripped portion of wire is in the core crimp area and the insulated portion of the wire is in the insulation crimping area (Figure E-6, View C).
6. Crimp the stripped section of the wire.
7. Remove the terminal from the crimping tool.

APPENDIX E — CONNECTOR PART NUMBERS, TERMINAL PART NUMBERS, TOOL PART NUMBERS, AND REPAIR INSTRUCTIONS**C. Terminal Crimping Using Crimping Tool J 38125-6 (cont'd)**

8. Push the wire seal into the terminal (Figure E-6, View D). The second crimp will wrap around the wire seal. This will seal the insulated area of wire.
9. Use a pair of needle nose pliers, if necessary, to squeeze the terminal wings together to fit in anvil "5."
10. Crimp wire seal in anvil "5."
11. Tug on terminal and be sure the crimp is tight.
12. Insert the terminal into the connector. The terminal will "click" into place and should not pull out.
13. Secure the secondary lock. Both sides of the connector must be latched.

D. Terminal Crimping Using Alternate Crimper Pliers J 35606 or J 38852

1. Place the wire seal onto the wire before stripping the wire (Figure E-6, View C).
2. Strip wire to 6.0 ± 0.25 mm (0.24 ± 0.01 inch).
3. Insert terminal into crimping tool J 35606 (Figure E-7, View A), opening marked 18-20.
4. Position the terminal so the crimp wings are pointing up from the bottom jaw of the crimper and are properly positioned.
5. Slightly close the crimping tool to hold the terminal steady.
6. Slide the wire seal to the edge of the insulation and insert the wire and seal into the terminal (Figure E-7, View B).
7. Position the wire and seal and squeeze the crimping tool until it opens when released.
8. Tug on terminal to be sure the crimp is tight.
9. Insert terminal into connector. The terminal will "click" into place and should not pull out.
10. Relatch the secondary lock. Both sides of the connector must be latched.

APPENDIX E — CONNECTOR PART NUMBERS, TERMINAL PART NUMBERS, TOOL PART NUMBERS, AND REPAIR INSTRUCTIONS

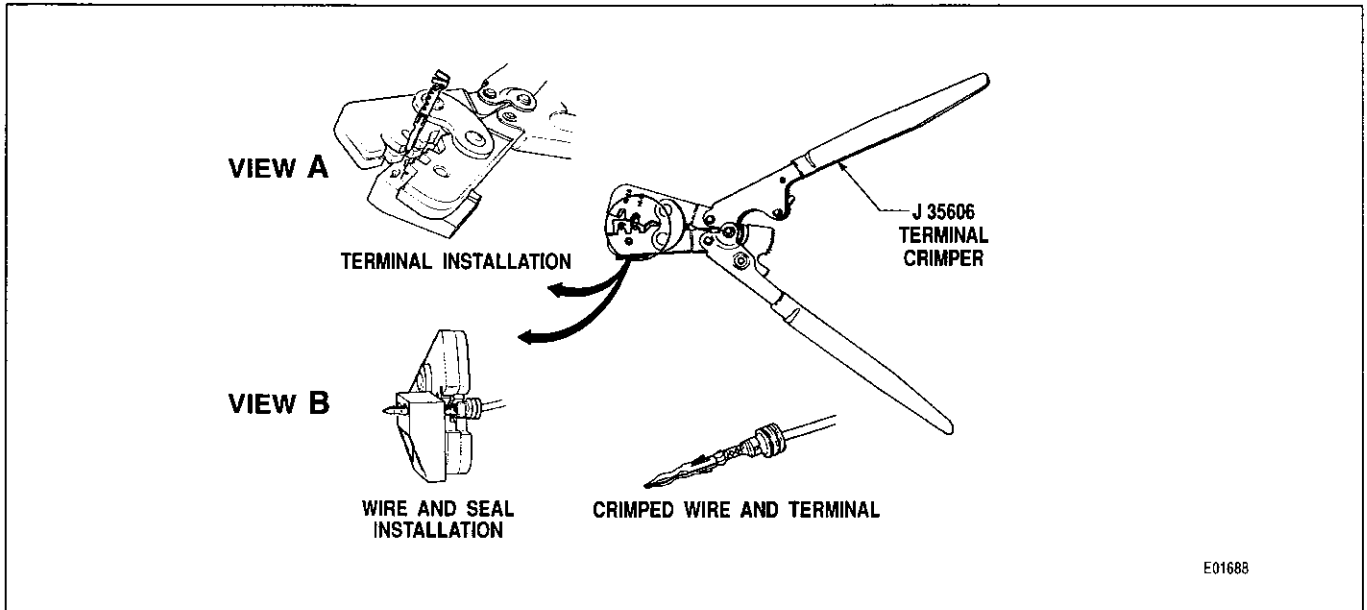
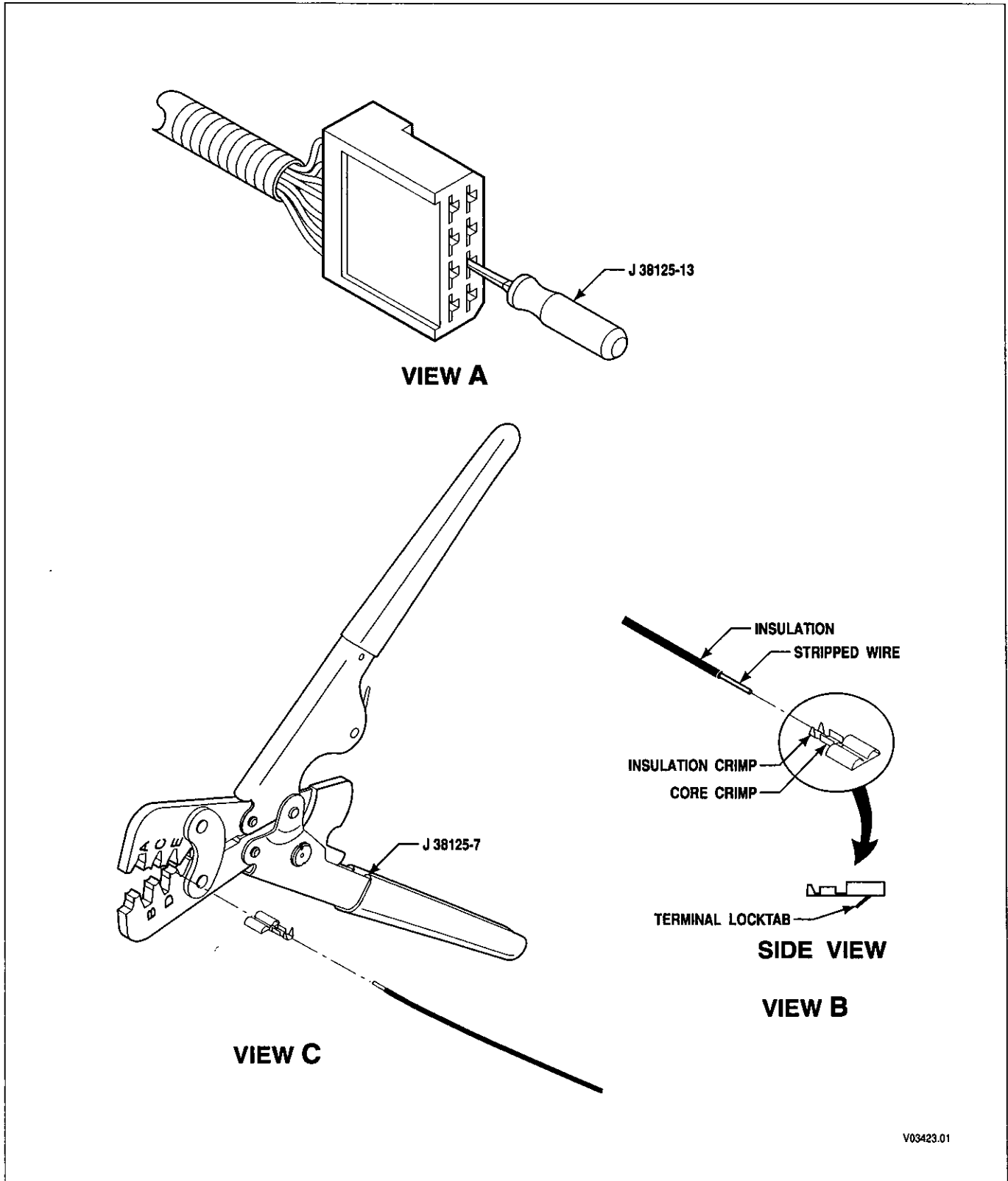

Figure E-8. Terminal Crimping With Tool J 35606

APPENDIX E — CONNECTOR PART NUMBERS, TERMINAL PART NUMBERS, TOOL PART NUMBERS, AND REPAIR INSTRUCTIONS



V03423.01

Figure E-9. Amp Products Connectors (8-Way RMR Device (Hand Lever))

APPENDIX E — CONNECTOR PART NUMBERS, TERMINAL PART NUMBERS, TOOL PART NUMBERS, AND REPAIR INSTRUCTIONS

1-8. AMP PRODUCTS CONNECTORS (8-WAY RMR DEVICE (HAND LEVER))

A. Connector/Terminal Repairs

Crimping Tool	J 38125-7
Wire Crimp	Anvil "E"
Insulation Crimp	Anvil "A"
Remover Tool	J 38125-13

Use	Description	Manufacturers P/N
8-Way RMR Device (Hand Lever)	8-Way Receptacle	163007-0
	Terminal (Socket)	42100-2

B. Terminal Removal

1. Insert removal tool J 38125-13 into the small notch at the front of the connector to release the terminal locktab (Figure E-8, View A).
2. Pull the terminal and wire out the back of the connector.
3. If replacing terminal, cut terminal between core and insulation crimp (this minimizes wire loss).

C. Terminal Crimping

1. Strip wire to approximately 4.0 ± 0.25 mm (0.16 ± 0.01 inch) (Figure E-8, View B).
2. Place new terminal onto crimping tool J 38125-7, anvil "E" (Figure E-8, View C).
3. Slightly close the crimping tool to hold the terminal steady.
4. Insert the wire so that the stripped portion of the wire is in the core crimp area and the insulated portion of the wire is in the insulation crimping area.
5. Crimp the stripped section of the wire (Figure E-8, View B).
6. Remove the terminal from the crimping tool.
7. Use a pair of needle nose pliers, if necessary, to start the bend on the insulation crimp wings.
8. Crimp the insulated section of the wire using anvil "A" of the crimpers (Figure E-8, View C).
9. Remove the terminal from the crimping tool.
10. Tug on the terminal to make sure the crimp is tight.
11. Insert the terminal into the connector. The terminal will "click" into place and should not pull out.

APPENDIX E — CONNECTOR PART NUMBERS, TERMINAL PART NUMBERS, TOOL PART NUMBERS, AND REPAIR INSTRUCTIONS

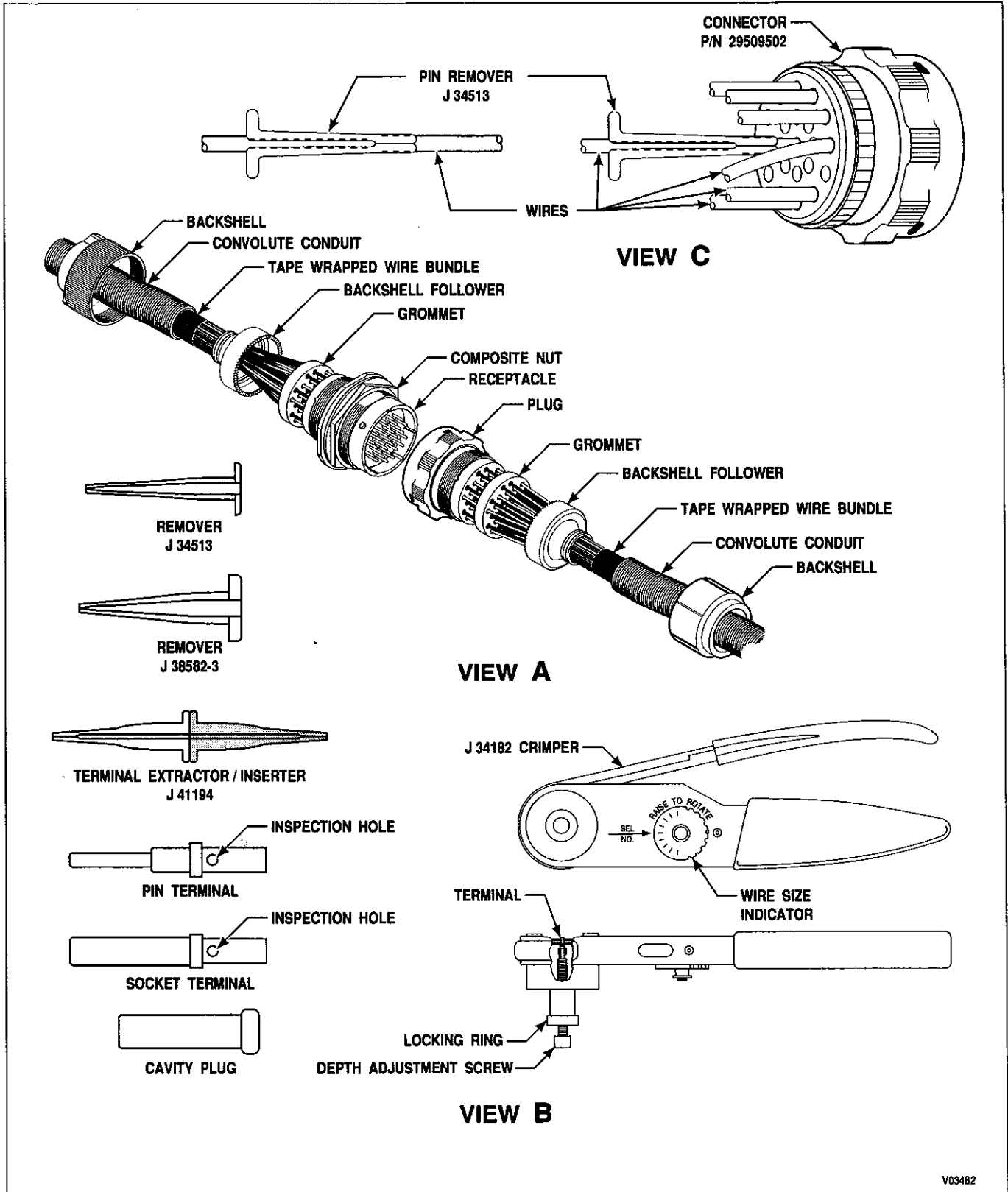

V03482

Figure E-10. Deutsch IPD/ECD Connectors (31-Way Bulkhead, 31-Way Feedthrough Harness; 16-Way Optional Sensor Harness; 6-Way Optional DDR)

APPENDIX E — CONNECTOR PART NUMBERS, TERMINAL PART NUMBERS, TOOL PART NUMBERS, AND REPAIR INSTRUCTIONS

1-9. DEUTSCH IPD/ECD CONNECTORS (31-WAY BULKHEAD; 31-WAY FEEDTHROUGH HARNESS; 16-WAY OPTIONAL SENSOR HARNESS; 6-WAY OPTIONAL DDR)

A. Connector/Terminal Repairs

Crimping Tool	J 34182
Remover Tool	J 34513 (18 GA IPD Bulkhead)
Extractor/Inserter Tool	J 41194 (18 GA ECD Bulkhead)
Remover Tool (DDR Connector)	J 38582-3 (12-14 GA)

Use	Description	Manufacturers P/N
Bulkhead Connector/ Transmission Connector — ECD	Connector Plug, 31-Way (Male/Female)	
	31-Pin Plug	WT06B24-31SN
	Terminal (Socket)	3662-204-1690
	Cavity Plug	0613-1-1601
	Backshell Housing	WTA10-24-01/19
	Backshell Follower	WTA10-24-02/19
	Backshell Grommet	WTA10-24-03
	Connector Receptacle, 31-Way	(Female/Male)
	31-Pin Receptacle	WT04B24-31PN
	Terminal (Pin)	3660-201-1690
	Cavity Plug	0613-1-1601
	Panel Nut	0926-208-2401
	O-Ring Seal	9013-3-0402
	Lockwasher	0914-212-2486
	Backshell Housing	WTA10-24-01/19
	Backshell Follower	WTA10-24-02/19
Backshell Grommet	WTA10-24-03	
Bulkhead Connector — ECD	Connector Plug (31-Way) (Male/Male)	
	31-Pin Plug	WT06B24-31PN
	Terminal (Pin)	3660-201-1690
	Cavity Plug	0613-1-1601
	Backshell Housing	WTA10-24-01/19
	Backshell Follower	WTA10-24-02/19
	Backshell Grommet	WTA10-24-03
	Connector Receptacle (31-Way)	(Female/Female)
	31-Pin Receptacle	WT04B24-31SN
	Terminal (Socket)	3662-204-1690
	Cavity Plug	0613-1-1601
	Panel Nut	0926-208-2401
	O-Ring Seal	9013-3-0402
	Lockwasher	0914-212-2486
	Backshell Housing	WTA10-24-01/19
	Backshell Follower	WTA10-24-02/19
Backshell Grommet	WTA10-24-03	

APPENDIX E — CONNECTOR PART NUMBERS, TERMINAL PART NUMBERS, TOOL PART NUMBERS, AND REPAIR INSTRUCTIONS

Use	Description	Manufacturers P/N
16-Way Optional Sensor Harness	16-Way Plug	WT06B20-16SN
	Terminal (Socket)	3662-204-1690
	Cavity Plug	0613-1-1601
	Backshell Housing	WTA10-20-01/16
	Backshell Follower	WTA10-20-02/16
	Backshell Grommet	WTA10-20-03
	16-Way Receptacle	WT04B20-16PN
	Terminal (Pin)	3660-201-1690
	Cavity Plug	0613-1-1601
	Panel Nut	0926-207-2087
	O-Ring Seal	9013-3-0201
	Lockwasher	9014-212-2086
	Backshell Housing	WTA10-20-01/16
	Backshell Follower	WTA10-20-02/16
Backshell Grommet	WTA10-20-03	
6-Way Optional DDR	6-Way Plug	HD10-6-12P
	Terminal (Pin)	0460-256-12233
	Terminal (Pin)	0460-204-0831
	Cavity Plug	114017
	Backshell	HD18-006
	Cover	HDC16-6
9-Way Optional DDR	9-Way Receptacle	HD10-9-1939P

NOTE: *If difficulty is encountered in removing or installing the plug backshell, insert the plug into the receptacle, do not lock it into place, and loosen the backshell.*

B. Terminal Removal (Refer to Figure E-9, View A)

NOTE: *When using remover/insertor tool J 41194, take care not to break the tip of the tool. Lay the wire in the widest part of the wire slot and work toward the tool tip.*

1. Loosen and slide the backshell along the convolute conduit.
2. Remove the convolute conduit from the base of the backshell follower. Peel enough conduit from the harness to allow working access.
3. Slide the backshell follower clear of the connector housing.
4. Remove as much tape wrap as necessary to allow working access.
5. Fully insert the proper remover/extractor tool into the back of the connector until it releases the terminal.
6. Pull the terminal, wire, and tool out the back of the connector.
7. If replacing the terminal, cut the wire through the middle of the terminal crimp (this minimizes wire loss).

C. Terminal Crimping (Refer to Figure E-9, View B)

1. Strip approximately 6–8 mm (0.236–0.315 inch) of insulation from the wire.
2. Set the crimping tool wire size to number 18 for the ECD or IPD connector. For the optional DDR connector, set the wire size to number 12. To set the wire size, remove the retainer pin. Lift and rotate the indicator until the correct wire number is aligned with the SEL NO. arrow. Reinstall the retainer pin.

APPENDIX E — CONNECTOR PART NUMBERS, TERMINAL PART NUMBERS, TOOL PART NUMBERS, AND REPAIR INSTRUCTIONS

C. Terminal Crimping (Refer to Figure E-9, View B) (*cont'd*)

3. Insert the contact end of the terminal into crimping tool J 34182. Adjust the crimping tool depth by loosening the locking ring until the depth adjusting screw is free and turning the adjusting screw until the top of the terminal is just above flush with the crimping hole (the crimp jaws will contact the middle of the terminal barrel). Tighten the lock ring to retain the adjustment.
4. Fully insert the wire into the terminal so that the stripped portion of the wire is in the crimp area. A small section (0.5–1.0 mm (0.02–0.04 inch)) of wire will be visible above the terminal barrel.
5. Squeeze the crimping tool handle until it releases. The terminal is now crimped onto the wire.
6. Remove the terminal and wire from the crimping tool.
7. Tug on the terminal to ensure the crimp is tight.
8. For the optional DDR connector, apply a 25 mm (one inch) long piece of heat shrink tubing over the wire insulation just behind the terminal. Apply heat to shrink and lock tubing to the insulation.

D. Terminal Insertion (ECD Bulkhead)

NOTE: *If replacing an outside grommet (refer to Figure E-9 showing the ECD bulkhead), ensure the grommet is correctly installed. Each grommet hole is marked with the terminal ID of the wire that passes through that hole. The grommet holes match the pattern of either the pins or sockets in the connector. One side of the grommet is marked "PIN" and the other "SKT" or "SOC". "PIN" indicates the pin (receptacle) side of the connector and "SKT" or "SOC" the socket (plug) side. When installing the outer grommet in the receptacle, ensure "PIN" is showing and positioned so that the "A" terminal ID on the outer grommet aligns with the "A" terminal ID on the inner grommet. When installing the outer grommet in the plug, "SKT" or "SOC" must be showing and positioned so that the "A" terminal ID on the outer grommet aligns with the "A" terminal ID on the inner grommet. Reversing "PIN" and "SKT" or "SOC" sides of the grommet will cause the grommet holes to be misaligned with the holes in either the receptacle or plug. Perform Steps (1) and (2) only if the outer grommet has been removed.*

1. Place the correct side of the grommet upwards with the inner and outer grommet "A" terminal ID aligned.
2. Insert two cavity plugs in unused cavities to retain the grommet.

NOTE: *When using remover/insertor tool J 41194, take care not to break the tip of the tool. Lay the wire in the widest part of the wire slot and work toward the tool tip.*

3. Place the terminal and wire in the end of extractor/insertor tool J 41194.
4. Insert the tool through the grommet, into the back of the connector, and push until the terminal is seated. Remove the remover/insertor tool.
5. Insert cavity plugs into all unused cavities.
6. Wrap plastic electrical tape around the wire bundle.
7. Reassemble the connector in the reverse order of disassembly.

E. Terminal Insertion (all connectors except ECD bulkhead)

1. Insert wire with crimped terminal through the proper hole in the grommet.
2. Keep pushing on wire until the terminal "locks" into position.

APPENDIX E — CONNECTOR PART NUMBERS, TERMINAL PART NUMBERS, TOOL PART NUMBERS, AND REPAIR INSTRUCTIONS

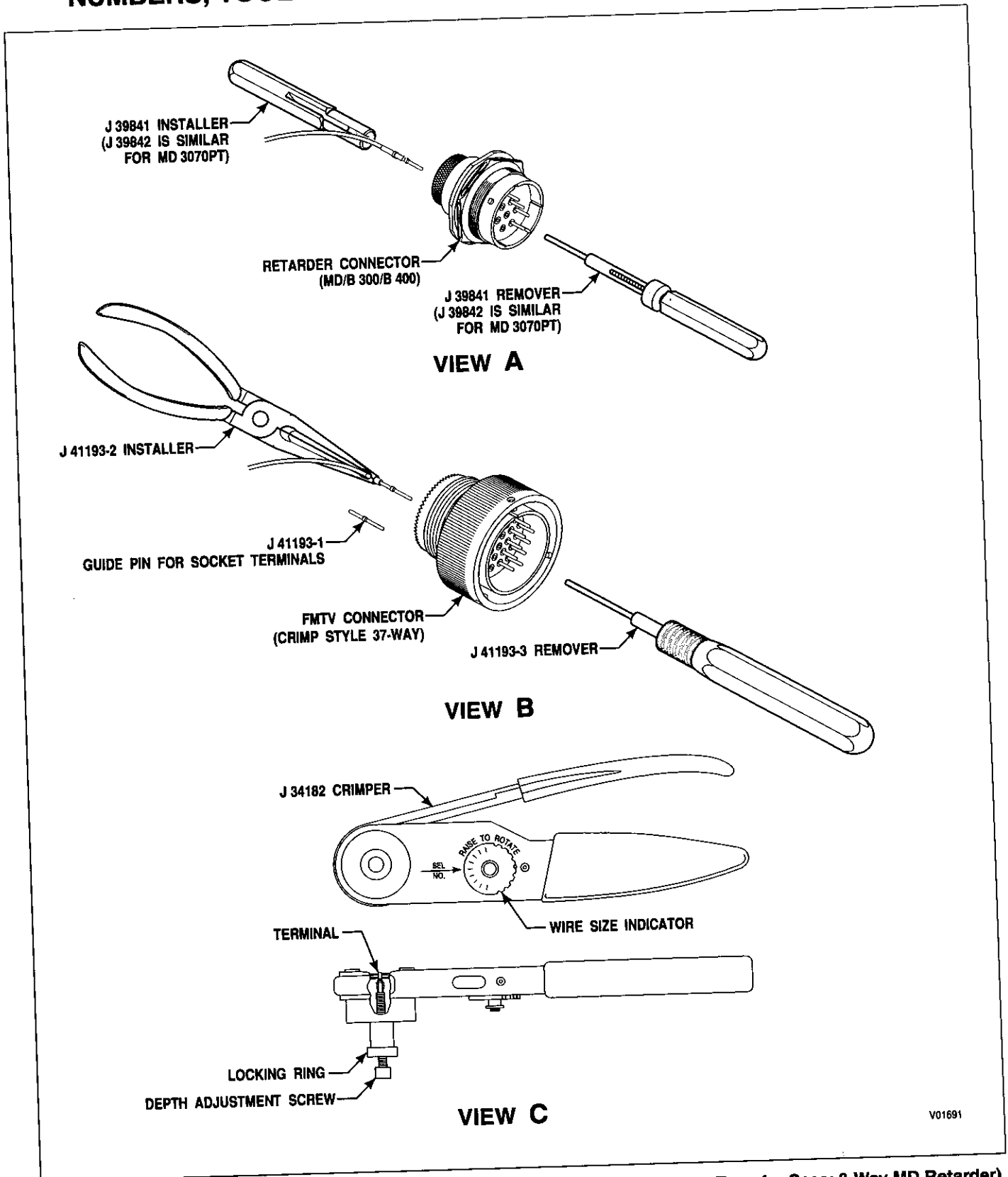

Figure E-11. ITT Cannon Connectors — Crimped (37-Way FMTV Bulkhead; 6-Way Transfer Case; 8-Way MD Retarder)

APPENDIX E — CONNECTOR PART NUMBERS, TERMINAL PART NUMBERS, TOOL PART NUMBERS, AND REPAIR INSTRUCTIONS

1-10. ITT CANNON CONNECTORS — CRIMPED (37-WAY FMTV BULKHEAD; 6-WAY TRANSFER CASE; 8-WAY MD RETARDER)

A. Connector/Terminal Repair

Crimping Tool	J 34182
Connector Repair Kit (FMTV)	J 41193
Guide Pin	J 41193-1
Insertion Tool	J 41193-2
Terminal Remover	J 41193-3
Terminal Remover/Installer (MD Retarder)	J 39841
Terminal Remover/Installer (MD 3070 T-Case Connector)	J 39842

Use	Description	Manufacturers P/N
MD FMTV	37-Way Plug Assembly	CA3106E28-21P-B
	37-Way Receptacle Assembly	CA3100E28-21S-B
MD Transfer Case	6-Way Plug Assembly	KPSE06E10-6S
	Terminal (Socket)	031-9174-004
	Cavity Plug	225-0070-000
	6-Way Receptacle Assembly	KPSE07E10-6P
	Terminal (Pin)	030-9173-006
	Cavity Plug	225-0070-000
MD Retarder	8-Way Plug	KPSE06E16-8S
	Terminal, Socket	031-9206-006
	Cavity Plug	225-0071-000
	8-Way Receptacle	KPSE07E16-8P
	Terminal (Pin)	030-9205-007
	Cavity Plug	225-0071-000

B. Terminal Removal (Refer to Figure E-10, View A and B)

1. Select the remover tool for the plug or receptacle that is being repaired.
2. For the FMTV connector, choose either the pin or socket terminal remover tip and lock it into the handle.
3. Place the tip of the remover tool over the pin or into the socket and push the contact/terminal out the rear of the connector using slow, even pressure.
4. Pull the wire and terminal out the back of the connector.
5. If replacing the terminal, cut the wire through the middle of the terminal crimp to minimize wire loss.

APPENDIX E — CONNECTOR PART NUMBERS, TERMINAL PART NUMBERS, TOOL PART NUMBERS, AND REPAIR INSTRUCTIONS**C. Terminal Crimping (Refer to Figure E-10, View C)**

1. Strip approximately 6–8 mm (0.24–0.31 inch) of insulation from the wire.
2. Set the crimping tool wire size to number 18. To set the wire size, remove the retainer pin. Lift and rotate the indicator until 18 is aligned with the SEL NO. arrow. Reinstall the retainer pin.
3. Insert the contact end of the terminal down into crimping tool J 34182. Adjust the crimping tool depth by loosening the locking ring until the depth adjusting screw is free and turning the adjusting screw until the wire end of the terminal is just above flush with the top of the crimping hole. The crimp jaws will now contact the middle of the terminal barrel. Tighten the lock ring to retain the adjustment.
4. Fully insert the wire into the terminal so that the stripped portion of the wire is in the crimp area. A small section (0.5–1.0 mm (0.020–0.040 inch)) of wire will be visible above the terminal barrel.
5. Squeeze the crimping tool handle until it releases. The terminal is now crimped onto the wire.
6. Remove the terminal and wire from the crimping tool.
7. Tug on the terminal to ensure the crimp is tight.

D. Terminal Insertion

1. Select the proper insertion tool for the connector or receptacle that is being reassembled.
2. Place the terminal and wire in the insertion tool (refer to Figure E-10, View A and B).

NOTE: *When installing a socket terminal for the FMTV plug, use the J 41193-1 guide pin.*

3. Insert the terminal through the correct hole in the back of the connector and push until the terminal is seated. Remove the insertion tool. Check to see that the terminal is at the same height as other terminals. Tug on the wire at the rear of the connector to ensure that the terminal is locked in place.
4. Insert cavity plugs into all unused cavities.

**APPENDIX E — CONNECTOR PART NUMBERS, TERMINAL PART
NUMBERS, TOOL PART NUMBERS, AND REPAIR INSTRUCTIONS**

NOTES

APPENDIX E — CONNECTOR PART NUMBERS, TERMINAL PART NUMBERS, TOOL PART NUMBERS, AND REPAIR INSTRUCTIONS

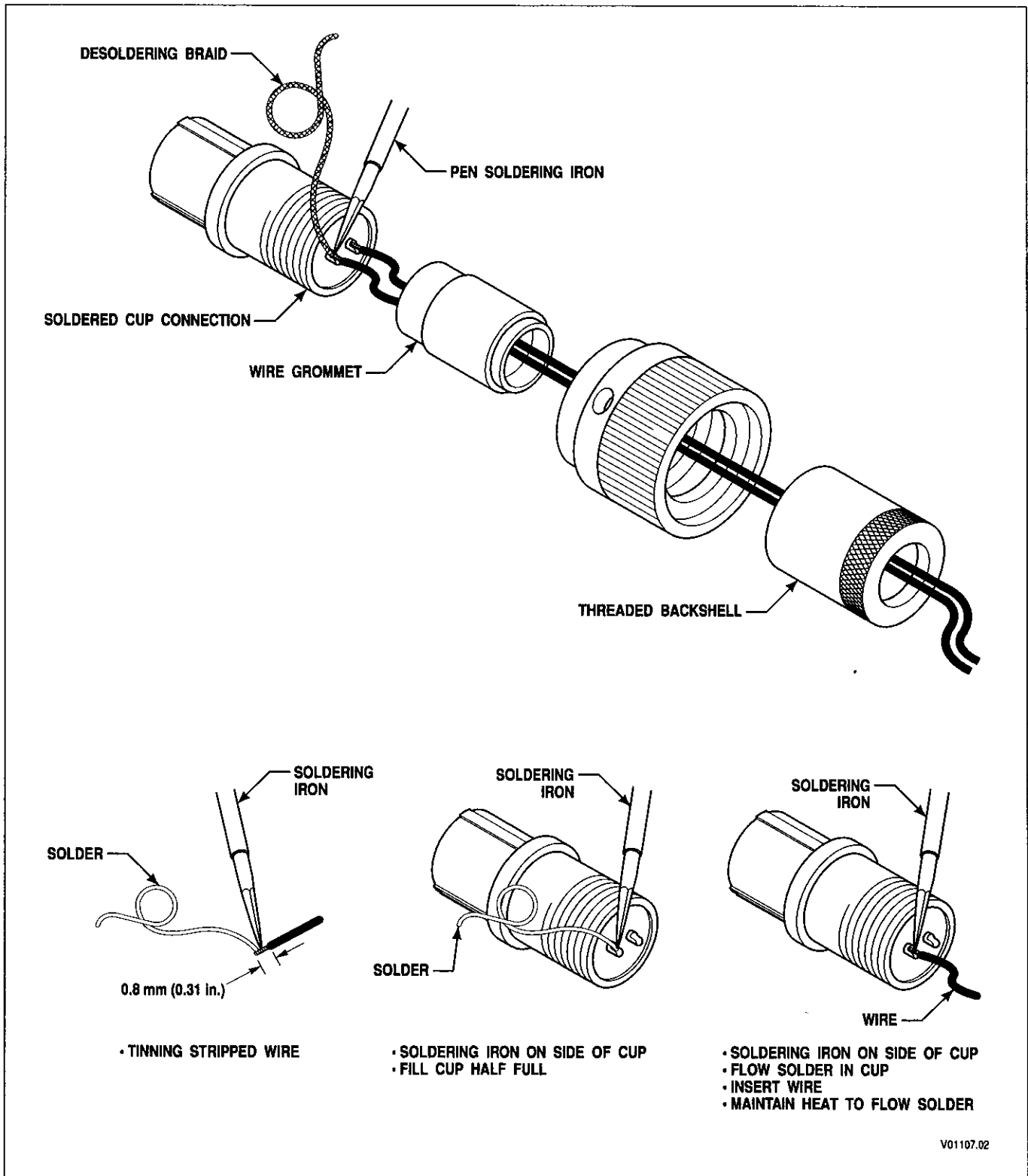

Figure E-12. ITT Cannon Connectors — Soldered (2-Way HD Retarder)

APPENDIX E — CONNECTOR PART NUMBERS, TERMINAL PART NUMBERS, TOOL PART NUMBERS, AND REPAIR INSTRUCTIONS

1-11. ITT CANNON CONNECTORS — SOLDERED (2-WAY HD RETARDER)

A. Connector Terminal Repair (Refer to Figure E-11)

Use	Description	Manufacturers P/N
Retarder Control (K Solenoid) (HD/B 500 Models)	Connector Plug (2-Pin)	KPT06E8-2S
	Terminal (Pin)	031-9074-002
	Connector Receptacle	KPT07E8-2P

B. Special Tools

- 50-70 percent tin resin core solder, 18-20 SWG (0.086-1.0 mm (0.036 to 0.040 inch))
- Pen-type soldering iron (60W maximum) — tip no larger than 3.175 mm (0.125 inch)
- Desoldering braid

NOTE: *Proper solder, techniques, equipment, and cleanliness are important to achieve a good solder joint. Clean connector and terminals being soldered of all dirt, grease, and oil. Always heat the piece onto which solder is to flow. A cold solder joint can cause intermittent continuity problems. Avoid a cold joint by heating the piece(s) being soldered to melt the solder rather than merely heating the solder until it melts. Excess solder applied to a stranded wire travels up the wire, stiffening it and making it inflexible. The wire can break at the point where the solder stops. Do not use acid core solder.*

C. Wire Removal — Desoldering

1. Unscrew the connector's backshell and slide the backshell away from the connector.
2. Slide the grommet away from the connector. Slide the grommet far enough to allow access to the terminals and wire ends. If the grommet is hard to slide, lubricate the wires with isopropyl alcohol. If necessary, move some of the harness covering. If no solder is present, proceed as in Section 1-9 for crimped terminals.
3. Place the desoldering braid (wick) on top of the soldered terminal cup and wire. Place the hot soldering iron on the desoldering braid and wait until the solder wicks up the braid, remove the wire.
4. If the other terminal is being repaired, repeat the desoldering operation on that terminal. When solder is removed, proceed as in Section 1-9 for crimped terminals.

D. Soldering Wire Into Terminal

NOTE: *If installing a new connector on a harness, ensure the backshell and grommet are in place before soldering the wires to the terminals. Clean wires and terminals of dirt or grease.*

1. Strip approximately 8 ± 0.8 mm (0.31 ± 0.03 inch) of insulation from the wire.
2. Tin the stripped end of the wire.
3. Insert the wire through the proper hole in the grommet.

NOTE: *Lubricate the wire(s) with isopropyl alcohol only if the wire(s) will not slide through the grommet. If installing a new connector on the harness, be sure the backshell is in place before inserting the wire(s) through the grommet.*

APPENDIX E — CONNECTOR PART NUMBERS, TERMINAL PART NUMBERS, TOOL PART NUMBERS, AND REPAIR INSTRUCTIONS**D. Soldering Wire Into Terminal** (*cont'd*)

4. Mount the connector in a holding fixture at a 45 degree angle. Hold the solder in the terminal cup and apply heat to the side of the cup until the solder flows.
5. Slowly feed solder into the cup until it is half-full. When the cup is half-full, remove the solder supply before removing the soldering iron. Half-fill all cup terminals that are to have wires inserted.

NOTE: *Feed solder slowly enough to prevent a flux gas pocket from forming. A gas pocket prevents sufficient solder from flowing into the cup — a false fill. Correct a false fill by re-heating the cup and adding solder.*

6. Start at the lowest cup and apply heat to the side of the cup until the solder melts.

NOTE: *Do not overheat the connector while soldering. If the connector gets too hot, stop work until it cools.*

7. Carefully insert the stripped end of the wire into the cup until the wire bottoms in the cup. The wire's insulation should be approximately 1.59 mm (0.0625 inch) above the solder.
8. Maintain heat until the solder has flowed in the cup and onto the wire. Overheating can cause the solder to wick up the stranded wire.

NOTE: *Indications of a good solder connection are:*

- *A minimum amount of solder showing*
- *Wire strands are clearly outlined in the joint*
- *The joint is completely covered with solder*
- *Fillets have a smooth even contour*
- *Edges are feathered*
- *The joint is bright, smooth, and appears clean*

Too little solder is better than too much. If the solder wicks up the wire, the wire may break at the point at which the solder stops.

9. After soldering and inspecting all connections, remove flux residue with a contact cleaner.
10. Slide the grommet into place and screw on the backshell.

APPENDIX E — CONNECTOR PART NUMBERS, TERMINAL PART NUMBERS, TOOL PART NUMBERS, AND REPAIR INSTRUCTIONS

NOTES

APPENDIX E — CONNECTOR PART NUMBERS, TERMINAL PART NUMBERS, TOOL PART NUMBERS, AND REPAIR INSTRUCTIONS

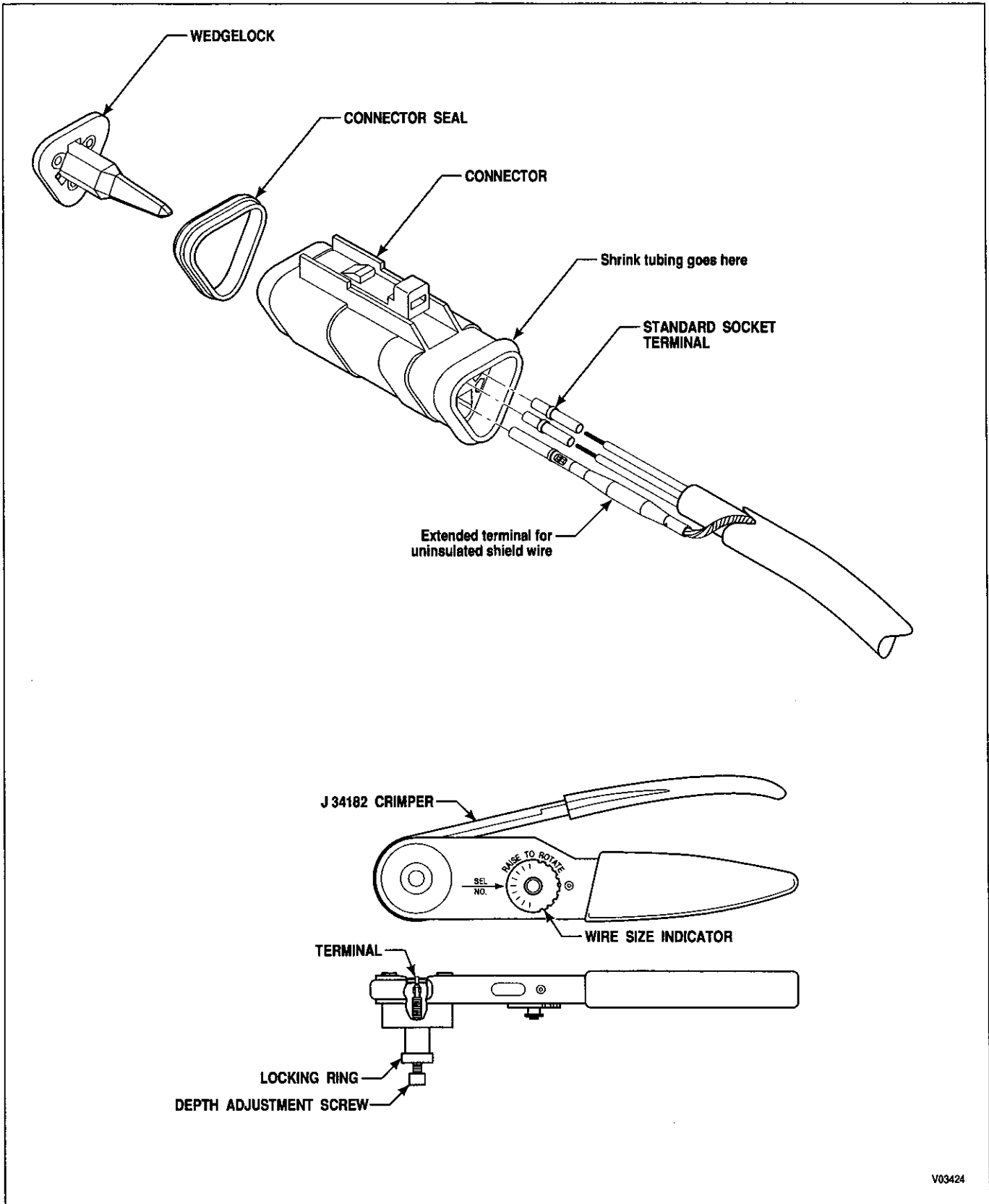

Figure E-13. Deutsch DT Series Connector (3-Way J1939 Interface)

APPENDIX E — CONNECTOR PART NUMBERS, TERMINAL PART NUMBERS, TOOL PART NUMBERS, AND REPAIR INSTRUCTIONS

1-12. DEUTSCH DT SERIES CONNECTORS (3-WAY J1939 INTERFACE)

A. Connector/Terminal Repair

Crimping Tool	J 34182	
Use	Description	Manufacturers P/N
J1939 Interface	Connector, Plug, 3-Way	DT06-3S-E008
	Wedglock, Plug	W3S-1939
	Contact, Socket (Standard)	3662-204-1690
	Contact, Socket (Extended)	0462-221-1631
	Cable, J1939 Databus	23-000-13

B. Terminal Removal (Refer to Figure E-12)

1. Use a small-bladed screwdriver to remove the wedglock that holds the terminals in place.
2. Use a sharp knife to carefully remove the shrink tubing from the rear of the connector plug.
3. Use a small screwdriver to release the locking lever for all of the terminals. Pull the wire and terminal out the rear of the connector.
4. Slide a new piece of shrink tubing over the removed terminals and onto the cable.
5. If replacing the terminal, cut the wire through the middle of the terminal crimp to minimize wire loss.

C. Terminal Crimping (Refer to Figure E-12)

1. Strip 6–8 mm (0.24–0.31 inch) of insulation from the wire. (There is no insulation on the shield wire.)
2. Set the crimping tool wire size to number 18. To set the wire size, remove the retainer pin. Lift and rotate the indicator until 18 is aligned with the SEL NO. arrow. Reinstall the retainer pin.
3. Insert the contact end of the terminal down into crimping tool J 34182. Adjust the crimping tool depth by loosening the locking ring until the depth adjusting screw is free and turning the adjusting screw until the wire end of the terminal is just above flush with the top of the crimping hole. The depth adjustment screw will need to be backed out a large amount to accept the extended shield terminal. The crimp jaws will now contact the middle of the terminal barrel. Tighten the lock ring to retain the adjustment.
4. Fully insert the wire into the terminal so that the stripped portion of the wire is in the crimp area. A small section (0.5–1.0 mm (0.02–0.04 inch)) of wire will be visible above the terminal barrel.
5. Squeeze the crimping tool handle until it releases. The terminal is now crimped onto the wire.
6. Remove the terminal and wire from the crimping tool.
7. Tug on the terminal to ensure the crimp is tight.

APPENDIX E — CONNECTOR PART NUMBERS, TERMINAL PART NUMBERS, TOOL PART NUMBERS, AND REPAIR INSTRUCTIONS

D. Terminal Insertion

1. Slide the wire with crimped terminal attached into the rear of the connector.
2. Push the terminal and wire into the connector until it locks into position (refer to Figure E-12). Check the front of the connector to see that the terminal is at the same height as other terminals. Tug on the wire at the rear of the connector to ensure that the terminal is locked in place.
3. Insert the wedge lock to hold the terminals in place. Slide the sealing plug back into place at the rear of the connector.
4. Slide the shrink tubing over the raised area at the rear of the connector. Use a heat gun to shrink the tubing into position over the connector and cable.

APPENDIX E — CONNECTOR PART NUMBERS, TERMINAL PART NUMBERS, TOOL PART NUMBERS, AND REPAIR INSTRUCTIONS

1-13. REPAIR OF A BROKEN WIRE WITH IN-LINE BUTT SPLICE

A. Connector Check Before Repair

NOTE: *Before repairing or replacing wiring harness, sensor, solenoid, switch, or ECU as indicated for a diagnosed problem, follow the procedure below:*

1. Disconnect the connector or connectors associated with the problem and inspect for:

- Bent terminals
- Broken terminals
- Dirty terminals
- Pushed back terminals
- Missing terminals
- Condition of mating tabs
- Condition of mating terminals

Ensure that terminals are secure in the connector. Clean, straighten, or replace parts as required.

2. Reconnect all previous unmated connectors. Ensure connectors are fully inserted or twisted until they lock in place. Connectors with locking tabs make an audible “click” when the lock is engaged.
3. If trouble recurs after starting the vehicle, follow proper repair procedures for trouble code or complaint.
4. If trouble does not recur, or if the correct repairs and/or replacements have been made, the problem should be corrected.

B. Special Tools

- Heat Gun, J 25070 or equivalent
- Crimping Tool for Pre-insulated Crimp J 38125-8 (refer to Figure E-13)

NOTE: *Use crimping anvils “F” and “G.”*

- Wire Strippers, J 35615
- Splices P/N 23046604 14–16 AWG
- Splices P/N 23046605 18–22 AWG

NOTE: *Each splice must be properly crimped and then heated to shrink the covering to protect and insulate the splice. Insulation piercing splice clips should not be used.*

APPENDIX E — CONNECTOR PART NUMBERS, TERMINAL PART NUMBERS, TOOL PART NUMBERS, AND REPAIR INSTRUCTIONS

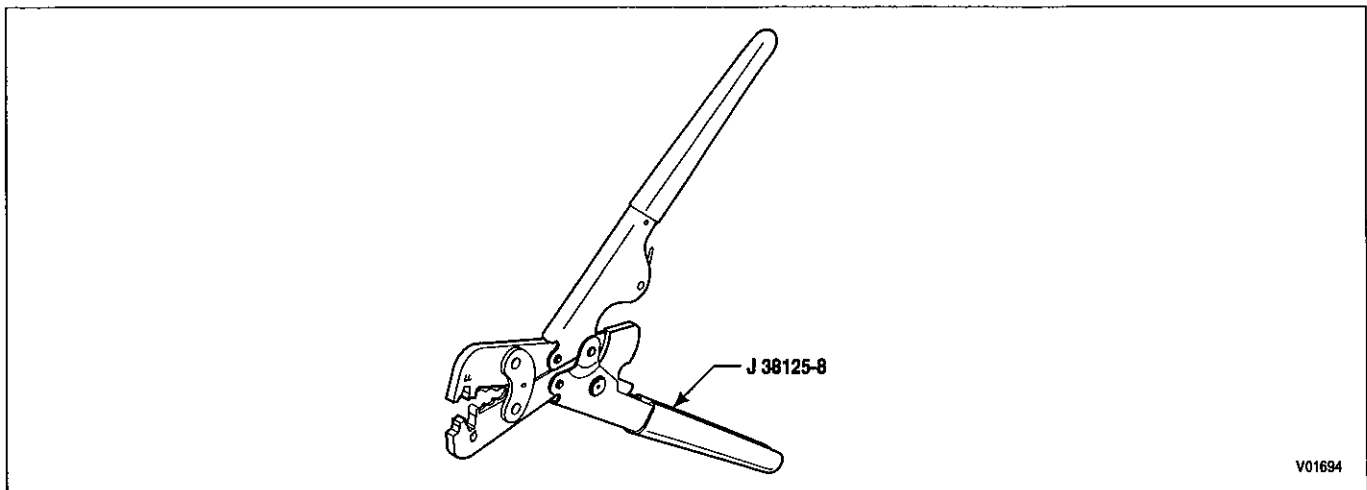

Figure E-14. Crimper J 38125-8

C. Straight Lead Repair Procedure

1. Locate damaged wire.
2. Remove insulation 8.0 mm (0.3 inch).
3. Insert one wire into crimp barrel and crimp.
4. Insert other wire into crimp barrel and crimp.
5. Pull on connection to ensure crimping integrity.
6. Heat splice with heat gun until covering shrinks and adhesive flows from under the covering.
7. The splice is now sealed and insulated. Electrical tape should not be used and is not necessary.

APPENDIX E — CONNECTOR PART NUMBERS, TERMINAL PART NUMBERS, TOOL PART NUMBERS, AND REPAIR INSTRUCTIONS

CONNECTOR	MFG. P/N	PART NAME	MANUFACTURER	CONFIG	MATING P/N	MFG. P/N	MATING PART NAME
ECU S	12191001	STRAIN RELIEF, 32-WAY BLACK	DELPHI-PACKARD	1-PC/ECU S	12186041	12186041	ECU HEADER
ECU S	15305333	SEAL, 32-WAY	DELPHI-PACKARD	1-PC/ECU S			
ECU S	15305371	INNER CONNECT, 32-WAY	DELPHI-PACKARD	1-PC/ECU S			
ECU S	12129021	TPA, 32-WAY BLACK	DELPHI-PACKARD	1-PC/ECU S			
ECU S	12084912	TERMINAL, SOCKET 100W	DELPHI-PACKARD	1-PC/ECU S			
ECU S	12129557	CAVITY PLUG, 100W	DELPHI-PACKARD	1-PC/ECU S			
ECU S	12177289	CPA, 32-WAY RED	DELPHI-PACKARD	1-PC/ECU S			
ECU V	12191002	STRAIN RELIEF, 32-WAY GRAY	DELPHI-PACKARD	1-PC/ECU V	12186043	12186043	ECU HEADER
ECU V	15305333	SEAL, 32-WAY	DELPHI-PACKARD	1-PC/ECU V			
ECU V	15305371	INNER CONNECT, 32-WAY	DELPHI-PACKARD	1-PC/ECU V			
ECU V	12129022	TPA, 32-WAY GRAY	DELPHI-PACKARD	1-PC/ECU V			
ECU V	12084912	TERMINAL, SOCKET 100W	DELPHI-PACKARD	1-PC/ECU V			
ECU V	12129557	CAVITY PLUG, 100W	DELPHI-PACKARD	1-PC/ECU V			
ECU V	12177289	CPA, 32-WAY RED	DELPHI-PACKARD	1-PC/ECU V			
ECU T	12191003	STRAIN RELIEF, 32-WAY BLUE	DELPHI-PACKARD	1-PC/ECU T	12129008	12129008	ECU HEADER
ECU T	15305333	SEAL, 32-WAY	DELPHI-PACKARD	1-PC/ECU T			
ECU T	15305371	INNER CONNECT, 32-WAY	DELPHI-PACKARD	1-PC/ECU T			
ECU T	12129023	TPA, 32-WAY BLUE	DELPHI-PACKARD	1-PC/ECU T			
ECU T	12084912	TERMINAL, SOCKET 100W	DELPHI-PACKARD	1-PC/ECU T			
ECU T	12129557	CAVITY PLUG, 100W	DELPHI-PACKARD	1-PC/ECU T			
ECU T	12177289	CPA, 32-WAY RED	DELPHI-PACKARD	1-PC/ECU T			
PSS/SSS	12160280	CONN 20F MIC/P 100W GRAY	DELPHI-PACKARD	1-PC/COMP S	12160542	12160542	CONN 20M MIC/P 100W GRAY
PSS/SSS	15304882	CABLE SEAL, 14F GRAY	DELPHI-PACKARD	1-PC/COMP S	12110693	12110693	CABLE SEAL, 14M GREEN
PSS/SSS	12160494	LOCK, SECONDARY 20F GREEN	DELPHI-PACKARD	1-PC/COMP S	12191176	12191176	LOCK ASSIST/SEAL, 20M GREEN
PSS/SSS	12084912	TERMINAL, SOCKET 100W	DELPHI-PACKARD	1-PC/COMP S	12160551	12160551	TERMINAL, PIN 100W
PSS/SSS	12129557	CAVITY PLUG, 100W	DELPHI-PACKARD	1-PC/COMP S	12129557	12129557	CAVITY PLUG, 100W
PSS/SSS	12176394	CONDUIT CLIP, 13 mm BLACK	DELPHI-PACKARD	1-PC/COMP S	12176394	12176394	CONDUIT CLIP, 13 mm BLACK
DDR P	12048105	CONNECTOR, 12-WAY	DELPHI-PACKARD	1-PC/COMP S			DIAGNOSTIC DATA READER
DDR P	12048107	COVER, CONNECTOR	DELPHI-PACKARD	1-PC/COMP S			
DDR P	12034046	TERMINAL, 280F SPECIAL	DELPHI-PACKARD	1-PC/COMP S			
DDR P	12066214	TERMINAL, 280F (W/SCI), 2-WIRE	DELPHI-PACKARD	1-PC/COMP S			
DDR P	12020219	LOCK, SECONDARY	DELPHI-PACKARD	1-PC/COMP S			
DDR D	HD10-6-12P	CONNECTOR, REC., 6-WAY	DEUTSCH IPD	1-PC/COMP S			DIAGNOSTIC DATA READER
DDR D	0460-256-12233	CONTACT, PIN #12	DEUTSCH IPD	1-PC/COMP S			
DDR D	0460-204-0831	CONTACT, PIN #8	DEUTSCH IPD	1-PC/COMP S			
DDR D	114017	SEALING PLUG	DEUTSCH IPD	1-PC/COMP S			
DDR D	HD18-006	BACKSHELL - STRAIN RELIEF	DEUTSCH IPD	1-PC/COMP S			
DDR D	HDC16-6	CAP, DDR CONNECTOR	DEUTSCH IPD	1-PC/COMP S			

APPENDIX E — CONNECTOR PART NUMBERS, TERMINAL PART NUMBERS, TOOL PART NUMBERS, AND REPAIR INSTRUCTIONS

CONNECTOR	MFG. P/N	PART NAME	MANUFACTURER	CONFIG	MATING P/N	MFG. P/N	MATING PART NAME
SCI	15300027	CONNECTOR, 2-WAY	DELPHI-PACKARD	1-PC/COMP S	15300002		CONNECTOR, 2-WAY
SCI	12077411	TERMINAL, SOCKET	DELPHI-PACKARD	1-PC/COMP S	12048159	12048159	TERMINAL, PIN
SCI	12089444	SEAL, WIRE TYPE, SILICONE	DELPHI-PACKARD	1-PC/COMP S	12089444	12089444	SEAL, WIRE TYPE, SILICONE
SCI	15300014	LOCK, SECONDARY	DELPHI-PACKARD	1-PC/COMP S	15300014	15300014	LOCK, SECONDARY
J1939	DT06-3S-E008	CONNECTOR, PLUG 3-WAY	DEUTSCH	1-PC/EUC S		DT04-3P-E008	CONNECTOR, REC., 3-WAY
J1939	W3S	WEDGELOCK, PLUG	DEUTSCH	1-PC/EUC S		W3P	WEDGELOCK, RECEPTACLE
J1939	3662-204-1690	CONTACT, SOCKET #16	DEUTSCH	1-PC/EUC S	29511369	3660-201-1690	CONTACT, PIN #16
J1939	0462-221-1631	CONTACT, EXTENDED SOCKET	DEUTSCH	1-PC/EUC S		0460-247-1631	CONTACT, EXTENDED PIN
J1939		CABLE, J1939 DATABUS		1-PC/EUC S			
VIM	12040920	CONNECTOR, BODY, 18-WAY	DELPHI-PACKARD	1-PC/COMP V	12052130	12052130	VIM HEADER ASSEMBLY
VIM	12040936	SEAL, 9-WAY	DELPHI-PACKARD	1-PC/COMP V			
VIM	12110545	STRAIN RELIEF, 18-WAY	DELPHI-PACKARD	1-PC/COMP V			
VIM	12129426	BOLT, 7mm HEAD EXT.	DELPHI-PACKARD	1-PC/COMP V			
VIM	12034236	RETAINER CLIP, BOLT	DELPHI-PACKARD	1-PC/COMP V			
VIM	12103881	TERMINAL, 150F	DELPHI-PACKARD	1-PC/COMP V			
VIM	12034413	CAVITY PLUG, METRI-PACK	DELPHI-PACKARD	1-PC/COMP V			
V1W S	12160542	CONN 20M MIC/P 100W GRAY	DELPHI-PACKARD	1-PC/COMP S	12160280	12160280	CONN 20F MIC/P 100W GRAY
V1W S	12110693	CABLE SEAL, 14M GREEN	DELPHI-PACKARD	1-PC/COMP S	15304882	15304882	CABLE SEAL, 14F GRAY
V1W S	12191178	LOCK ASSIST/SEAL, 20M WHITE	DELPHI-PACKARD	1-PC/COMP S	12191173	12191173	LOCK, SECONDARY 20F WHITE
V1W S	12160551	TERMINAL, PIN 100W	DELPHI-PACKARD	1-PC/COMP S	12084912	12084912	TERMINAL, SOCKET 100W
V1W S	12129557	CAVITY PLUG, 100W	DELPHI-PACKARD	1-PC/COMP S	12129557	12129557	CAVITY PLUG, 100W
V1W S	12176394	CONDUIT CLIP, 13 mm BLACK	DELPHI-PACKARD	1-PC/COMP S	12176394	12176394	CONDUIT CLIP, 13 mm BLACK
V1W V	12160542	CONN 20M MIC/P 100W GRAY	DELPHI-PACKARD	1-PC/COMP V	12160280	12160280	CONN 20F MIC/P 100W GRAY
V1W V	12110693	CABLE SEAL, 14M GREEN	DELPHI-PACKARD	1-PC/COMP V	15304882	15304882	CABLE SEAL, 14F GRAY
V1W V	12191177	LOCK ASSIST/SEAL, 20M BLUE	DELPHI-PACKARD	1-PC/COMP V	12191172	12191172	LOCK, SECONDARY 20F BLUE
V1W V	12160551	TERMINAL, PIN 100W	DELPHI-PACKARD	1-PC/COMP V	12084912	12084912	TERMINAL, SOCKET 100W
V1W V	12129557	CAVITY PLUG, 100W	DELPHI-PACKARD	1-PC/COMP V	12129557	12129557	CAVITY PLUG, 100W
V1W V	12176394	CONDUIT CLIP, 13 mm BLACK	DELPHI-PACKARD	1-PC/COMP V	12176394	12176394	CONDUIT CLIP, 13 mm BLACK
V1W V	12191505	COVER, CONNECTOR	DELPHI-PACKARD	1-PC/COMP V			
RMR	12015795	CONNECTOR, 3-WAY	DELPHI-PACKARD	1-PC/COMP S,T	12015092	12015092	CONNECTOR, SHROUD 3-WAY
RMR	12089040	TERMINAL, PIN	DELPHI-PACKARD	1-PC/COMP S,T	12089188	12089188	TERMINAL, SOCKET
RMR	12089444	SEAL, WIRE TYPE, SILICONE	DELPHI-PACKARD	1-PC/COMP S,T	12089444	12089444	SEAL, WIRE TYPE, SILICONE
NE	12162193	CONNECTOR, 2-WAY	DELPHI-PACKARD	1-PC/COMP T	12066016		ENGINE SPEED SENSOR
NE	12103881	TERMINAL, 150F	DELPHI-PACKARD	1-PC/COMP T			Actual sensor uses molded receptacle similar to 12066016
NO	12162193	CONNECTOR, 2-WAY	DELPHI-PACKARD	1-PC/COMP T			OUTPUT SPEED SENSOR
NO	12103881	TERMINAL, 150F	DELPHI-PACKARD	1-PC/COMP T			Actual sensor uses molded receptacle similar to 12066016
NT	12162193	CONNECTOR, 2-WAY	DELPHI-PACKARD	1-PC/COMP T			TURBINE SPEED SENSOR
NT	12103881	TERMINAL, 150F	DELPHI-PACKARD	1-PC/COMP T			Actual sensor uses molded receptacle similar to 12066016
TPS	12015793	CONNECTOR, 3-WAY	DELPHI-PACKARD	1-PC/COMP V,T			TPS HEADER
TPS	12089040	TERMINAL, PIN	DELPHI-PACKARD	1-PC/COMP V,T			TPS header similar to 12010717 connector with 12089188 sockets
TPS	12089444	SEAL, WIRE TYPE, SILICONE	DELPHI-PACKARD	1-PC/COMP V,T			molded into the TPS.

APPENDIX E — CONNECTOR PART NUMBERS, TERMINAL PART NUMBERS, TOOL PART NUMBERS, AND REPAIR INSTRUCTIONS

CONNECTOR	MFG. P/N	PART NAME	MANUFACTURER	CONFIG	MATING P/N	MFG. P/N	MATING PART NAME
NSOL	15326143	CONNECTOR, 2-WAY	DELPHI-PACKARD	1-PC/COMP T	12084669		ACCUMULATOR SOLENOID
NSOL	12103881	TERMINAL, 150F	DELPHI-PACKARD	1-PC/COMP T	Actual solenoid uses molded receptacle similar to 12084669		
RTEMP	12010973	CONNECTOR, SHROUD, 2-WAY	DELPHI-PACKARD	1-PC/COMP T	12015792	12015792	CONNECTOR, TOWER, 2-WAY
RTEMP	12089188	TERMINAL, SOCKET	DELPHI-PACKARD	1-PC/COMP T	12089040	12089040	TERMINAL, PIN
RTEMP	12089444	SEAL, WIRE TYPE, SILICONE	DELPHI-PACKARD	1-PC/COMP T	12089444	12089444	SEAL, SILICONE
RTEMP, V8A	12162852	CONNECTOR, 2-WAY	DELPHI-PACKARD	1-PC/COMP T	12015792	12015792	V8A RETARDER TEMPERATURE
RTEMP, V8A	12124075	TERMINAL, 150.2F	DELPHI-PACKARD	1-PC/COMP T			
XFER	KPSE06E10-6S	CONNECTOR ASSY, PLUG 6-WAY	ITT CANNON	1-PC/COMP T(7)		KPSE07E10-6P	TRANSFER CASE
RMOD	KPSE06E16-8S	CONNECTOR ASSY, PLUG 8-WAY	ITT CANNON	1-PC/COMP T	29505513	KPSE07E16-8P	CONNECTOR ASSY, REC 8-WAY
HSOLH	KPT06E8-2S	CONNECTOR ASSY, PLUG 2-WAY	ITT CANNON	1-PC/COMP T, HD	29505515	KPT07E8-2P	RETARDER SOLENOID, HDR
HSOLM	12162197	CONNECTOR, 2-WAY	DELPHI-PACKARD	1-PC/COMP T, MD	12084669		RETARDER SOLENOID, MDR
HSOLM	12103881	TERMINAL, 150F	DELPHI-PACKARD	1-PC/COMP T, MD	Actual solenoid uses molded receptacle similar to 12084669		
TRANS	WT06B24-31SN	CONNECTOR, PLUG, 31-WAY	DEUTSCH	1-PC/COMP T	29511368	WT04B24-31PN	CONNECTOR, REC., 31-WAY
TRANS	3662-204-1690	CONTACT, SOCKET #16	DEUTSCH	1-PC/COMP T	29511369	3660-201-1690	CONTACT, PIN #16
TRANS	0613-1-1601	SEALING PLUG	DEUTSCH	1-PC/COMP T	29511371	0613-1-1601	SEALING PLUG
TRANS	WTA10-24-01/19	HOUSING, BACKSHELL, 24/19	DEUTSCH	1-PC/COMP T	29514041	WTA10-24-01/19	HOUSING, BACKSHELL, 24/19
TRANS	WTA10-24-02/19	FOLLOWER, BACKSHELL, 24/19	DEUTSCH	1-PC/COMP T	29514042	WTA10-24-02/19	FOLLOWER, BACKSHELL, 24/19
TRANS	WTA10-24-03	GROMMET, BACKSHELL #24	DEUTSCH	1-PC/COMP T	29514043	WTA10-24-03	GROMMET, BACKSHELL #24
BLKHD RCS	WT04B24-31SN	CONNECTOR, REC., 31-WAY	DEUTSCH	ECU T/COMP V	29511855	WT06B24-31PN	CONNECTOR, PLUG, 31-WAY
BLKHD RCS	3662-204-1690	CONTACT, SOCKET #16	DEUTSCH	ECU T/COMP V	29511369	3660-201-1690	CONTACT, PIN #16
BLKHD RCS	0613-1-1601	SEALING PLUG	DEUTSCH	ECU T/COMP V	29511371	0613-1-1601	SEALING PLUG
BLKHD RCS	WTA10-24-01/19	HOUSING, BACKSHELL, 24/19	DEUTSCH	ECU T/COMP V	29514041	WTA10-24-01/19	HOUSING, BACKSHELL, 24/19
BLKHD RCS	WTA10-24-02/19	FOLLOWER, BACKSHELL, 24/19	DEUTSCH	ECU T/COMP V	29514042	WTA10-24-02/19	FOLLOWER, BACKSHELL, 24/19
BLKHD RCS	WTA10-24-03	GROMMET, BACKSHELL #24	DEUTSCH	ECU T/COMP V	29514043	WTA10-24-03	GROMMET, BACKSHELL #24
BLKHD RCS	0926-208-2401	NUT, PANEL	DEUTSCH	ECU T/COMP V			
BLKHD RCS	9013-3-0402	O-RING	DEUTSCH	ECU T/COMP V			
BLKHD PGP	WT06B24-31PN	CONNECTOR, PLUG, 31-WAY	DEUTSCH	ECU V/COMP T	29511854	WT04B24-31SN	CONNECTOR, REC., 31-WAY
BLKHD PGP	3660-201-1690	CONTACT, PIN #16	DEUTSCH	ECU V/COMP T	29511366	3662-204-1690	CONTACT, SOCKET #16
BLKHD PGP	0613-1-1601	SEALING PLUG	DEUTSCH	ECU V/COMP T	29511371	0613-1-1601	SEALING PLUG
BLKHD PGP	WTA10-24-01/19	HOUSING, BACKSHELL, 24/19	DEUTSCH	ECU V/COMP T	29514041	WTA10-24-01/19	HOUSING, BACKSHELL, 24/19
BLKHD PGP	WTA10-24-02/19	FOLLOWER, BACKSHELL, 24/19	DEUTSCH	ECU V/COMP T	29514042	WTA10-24-02/19	FOLLOWER, BACKSHELL, 24/19
BLKHD PGP	WTA10-24-03	GROMMET, BACKSHELL #24	DEUTSCH	ECU V/COMP T	29514043	WTA10-24-03	GROMMET, BACKSHELL #24
					29527000	0926-208-2401	NUT, PANEL
					29512839	9013-3-0402	O-RING
BLKHD RCP	WTC04B24-31PN	CONNECTOR, REC., 31-WAY	DEUTSCH	COMP S	29511365	WT06B24-31SN	CONNECTOR, PLUG, 31-WAY
BLKHD RCP	3660-201-1690	CONTACT, PIN #16	DEUTSCH	COMP S	29511366	3662-204-1690	CONTACT, SOCKET #16
BLKHD RCP	0613-1-1601	SEALING PLUG	DEUTSCH	COMP S	29511371	0613-1-1601	SEALING PLUG
BLKHD RCP	WTA10-24-01/19	HOUSING, BACKSHELL, 24/19	DEUTSCH	COMP S	29514041	WTA10-24-01/19	HOUSING, BACKSHELL, 24/19
BLKHD RCP	WTA10-24-02/19	FOLLOWER, BACKSHELL, 24/19	DEUTSCH	COMP S	29514042	WTA10-24-02/19	FOLLOWER, BACKSHELL, 24/19
BLKHD RCP	WTA10-24-03	GROMMET, BACKSHELL #24	DEUTSCH	COMP S	29514043	WTA10-24-03	GROMMET, BACKSHELL #24

APPENDIX E — CONNECTOR PART NUMBERS, TERMINAL PART NUMBERS, TOOL PART NUMBERS, AND REPAIR INSTRUCTIONS

CONNECTOR	MFG. P/N	PART NAME	MANUFACTURER	CONFIG	MATING P/N	MFG. P/N	MATING PART NAME
BLKHD RCP	0926-208-2401	NUT, PANEL	DEUTSCH	COMP S			
BLKHD RCP	9013-3-0402	O-RING	DEUTSCH	COMP S			
BLKHD PGS	WT06B24-31SN	CONNECTOR, PLUG, 31-WAY	DEUTSCH	ECU S	29511368	WT04B24-31PN	CONNECTOR, REC., 31-WAY
BLKHD PGS	3662-204-1690	CONTACT, SOCKET #16	DEUTSCH	ECU S	29511369	3660-201-1690	CONTACT, PIN #16
BLKHD PGS	0613-1-1601	SEALING PLUG	DEUTSCH	ECU S	29511371	0613-1-1601	SEALING PLUG
BLKHD PGS	WTA10-24-01/19	HOUSING, BACKSHELL, 24/19	DEUTSCH	ECU S	29514041	WTA10-24-01/19	HOUSING, BACKSHELL, 24/19
BLKHD PGS	WTA10-24-02/19	FOLLOWER, BACKSHELL, 24/19	DEUTSCH	ECU S	29514042	WTA10-24-02/19	FOLLOWER, BACKSHELL, 24/19
BLKHD PGS	WTA10-24-03	GROMMET, BACKSHELL #24	DEUTSCH	ECU S	29514043	WTA10-24-03	GROMMET, BACKSHELL #24
					29527000	0926-208-2401	NUT, PANEL
					29512839	9013-3-0402	O-RING
SENS	WT06B20-16SN	CONNECTOR, PLUG, 16-WAY	DEUTSCH	1-PC/COMP T (UNIV)	29516988	WT04B20-16PN	CONNECTOR, REC., 16-WAY
SENS	3662-204-1690	CONTACT, SOCKET #16	DEUTSCH	1-PC/COMP T (UNIV)	29511369	3660-201-1690	CONTACT, PIN #16
SENS	0613-1-1601	SEALING PLUG	DEUTSCH	1-PC/COMP T (UNIV)	29511371	0613-1-1601	SEALING PLUG
SENS	WTA10-20-01/16	HOUSING, BACKSHELL, 20/16	DEUTSCH	1-PC/COMP T (UNIV)	29516991	WTA10-20-01/16	HOUSING, BACKSHELL, 20/16
SENS	WTA10-20-02/16	FOLLOWER, BACKSHELL, 20/16	DEUTSCH	1-PC/COMP T (UNIV)	29516992	WTA10-20-02/16	FOLLOWER, BACKSHELL, 20/16
SENS	WTA10-20-03	GROMMET, BACKSHELL #20	DEUTSCH	1-PC/COMP T (UNIV)	29516993	WTA10-20-03	GROMMET, BACKSHELL #20
					29516989	0926-207-2087	NUT, PANEL #20
					29519126	0914-212-2086	LOCKWASHER, #20
SENSX	WT04B20-16PN	CONNECTOR, REC., 16-WAY	DEUTSCH	SENSOR	29516987	WT06B20-16SN	CONNECTOR, PLUG, 16-WAY
SENSX	3660-201-1690	CONTACT, PIN #16	DEUTSCH	SENSOR	29511366	3662-204-1690	CONTACT, SOCKET #16
SENSX	0613-1-1601	SEALING PLUG	DEUTSCH	SENSOR	29511371	0613-1-1601	SEALING PLUG
SENSX	WTA10-20-01/16	HOUSING, BACKSHELL, 20/16	DEUTSCH	SENSOR	29516991	WTA10-20-01/16	HOUSING, BACKSHELL, 20/16
SENSX	WTA10-20-02/16	FOLLOWER, BACKSHELL, 20/16	DEUTSCH	SENSOR	29516992	WTA10-20-02/16	FOLLOWER, BACKSHELL, 20/16
SENSX	WTA10-20-03	GROMMET, BACKSHELL #20	DEUTSCH	SENSOR	29516993	WTA10-20-03	GROMMET, BACKSHELL #20
SENSX	0926-207-2087	NUT, PANEL #20	DEUTSCH	SENSOR			
SENSX	0914-212-2086	LOCKWASHER, #20	DEUTSCH	SENSOR			
RTEMPX	12015792	CONNECTOR, TOWER, 2-WAY	DELPHI-PACKARD	ADAPTER (MDR)	12010973	12010973	CONNECTOR, SHROUD, 2-WAY
RTEMPX	12089040	TERMINAL, PIN	DELPHI-PACKARD	ADAPTER (MDR)	12089188	12089188	TERMINAL, SOCKET
RTEMPX	12089444	SEAL, SILICONE	DELPHI-PACKARD	ADAPTER (MDR)	12089444	12089444	SEAL, WIRE TYPE, SILICONE
NOX	12066016	CONNECTOR, 2-WAY	DELPHI-PACKARD	ADAPTER (MDR)	12162193	12162193	CONNECTOR, 2-WAY
					12103881	12103881	TERMINAL, 150F
HSOLMX		CONNECTOR MOLD, 2-WAY	DELPHI-PACKARD	SOLENOID (MDR)	12162197	12162197	CONNECTOR, 2-WAY
					12103881	12103881	TERMINAL, 150F
HSOLMXA	12084669	CONNECTOR, 2-WAY	DELPHI-PACKARD	ADAPTER (MDR)	12162197	12162197	CONNECTOR, 2-WAY
					12103881	12103881	TERMINAL, 150F
RMRX	12015092	CONNECTOR, SHROUD 3-WAY	DELPHI-PACKARD	RES. MODULE	12015795	12015795	CONNECTOR, 3-WAY
RMRX	12089188	TERMINAL, SOCKET	DELPHI-PACKARD	RES. MODULE	12089040	12089040	TERMINAL, PIN
RMRX	12089444	SEAL, WIRE TYPE, SILICONE	DELPHI-PACKARD	RES. MODULE	12089444	12089444	SEAL, WIRE TYPE, SILICONE
SCIX	15300002	CONNECTOR, SHROUD 2-WAY	DELPHI-PACKARD	SCI ADAPTER	15300027	15300027	CONNECTOR, 2-WAY
SCIX	12048159	TERMINAL, PIN	DELPHI-PACKARD	SCI ADAPTER	12077411	12077411	TERMINAL, SOCKET
SCIX	12089444	SEAL, WIRE TYPE, SILICONE	DELPHI-PACKARD	SCI ADAPTER	12089444	12089444	SEAL, WIRE TYPE, SILICONE
SCIX	15300014	LOCK, SECONDARY	DELPHI-PACKARD	SCI ADAPTER	15300014	15300014	LOCK, SECONDARY

APPENDIX E — CONNECTOR PART NUMBERS, TERMINAL PART NUMBERS, TOOL PART NUMBERS, AND REPAIR INSTRUCTIONS

CONNECTOR	MFG. P/N	PART NAME	MANUFACTURER	CONFIG	MATING P/N	MFG. P/N	MATING PART NAME
TRANSX	WT04B24-31PN	CONNECTOR, REC., 31-WAY	DEUTSCH	INTERNAL	29511365	WT06B24-31SN	CONNECTOR, PLUG, 31-WAY
TRANSX	3660-201-1690	CONTACT, PIN #16	DEUTSCH	INTERNAL	29511366	3662-204-1690	CONTACT, SOCKET #16
TRANSX	0613-1-1601	SEALING PLUG	DEUTSCH	INTERNAL	29511371	0613-1-1601	SEALING PLUG
TRANSX	WTA10-24-01/19	HOUSING, BACKSHELL, 24/19	DEUTSCH	INTERNAL	29514041	WTA10-24-01/19	HOUSING, BACKSHELL, 24/19
TRANSX	WTA10-24-02/19	FOLLOWER, BACKSHELL, 24/19	DEUTSCH	INTERNAL	29514042	WTA10-24-02/19	FOLLOWER, BACKSHELL, 24/19
TRANSX	WTA10-24-03	GROMMET, BACKSHELL #24	DEUTSCH	INTERNAL	29514043	WTA10-24-03	GROMMET, BACKSHELL #24
ASOL	12092420	CONNECTOR, 2-WAY SOLENOID	DELPHI-PACKARD	INTERNAL			SOLENOID A (C1)
ASOL	12124639	TERMINAL, 280 SERIES SOCKET	DELPHI-PACKARD	INTERNAL			
ASOL	12124618	TERMINAL, 280 SERIES SOCKET	DELPHI-PACKARD	INTERNAL			
BSOL	12092420	CONNECTOR, 2-WAY SOLENOID	DELPHI-PACKARD	INTERNAL			SOLENOID B (C2)
BSOL	12124639	TERMINAL, 280 SERIES SOCKET	DELPHI-PACKARD	INTERNAL			
BSOL	12124618	TERMINAL, 280 SERIES SOCKET	DELPHI-PACKARD	INTERNAL			
CSOL	12092420	CONNECTOR, 2-WAY SOLENOID	DELPHI-PACKARD	INTERNAL			SOLENOID C (C3)
CSOL	12124639	TERMINAL, 280 SERIES SOCKET	DELPHI-PACKARD	INTERNAL			
DSOL	12092420	CONNECTOR, 2-WAY SOLENOID	DELPHI-PACKARD	INTERNAL			SOLENOID D (C4)
DSOL	12124639	TERMINAL, 280 SERIES SOCKET	DELPHI-PACKARD	INTERNAL			
ESOL	12092420	CONNECTOR, 2-WAY SOLENOID	DELPHI-PACKARD	INTERNAL			SOLENOID E (C5)
ESOL	12124639	TERMINAL, 280 SERIES SOCKET	DELPHI-PACKARD	INTERNAL			
FSOL	12092420	CONNECTOR, 2-WAY SOLENOID	DELPHI-PACKARD	INTERNAL			SOLENOID F (LOCK-UP)
FSOL	12124639	TERMINAL, 280 SERIES SOCKET	DELPHI-PACKARD	INTERNAL			
GSOL	12092420	CONNECTOR, 2-WAY SOLENOID	DELPHI-PACKARD	INTERNAL			SOLENOID G (FORWARD)
GSOL	12124639	TERMINAL, 280 SERIES SOCKET	DELPHI-PACKARD	INTERNAL			
GSOL	12124618	TERMINAL, 280 SERIES SOCKET	DELPHI-PACKARD	INTERNAL			
JSOL	12092420	CONNECTOR, 2-WAY SOLENOID	DELPHI-PACKARD	INTERNAL (MD7)			SOLENOID J (C6)
JSOL	12124639	TERMINAL, 280 SERIES SOCKET	DELPHI-PACKARD	INTERNAL (MD7)			
NSOLI	12092420	CONNECTOR, 2-WAY SOLENOID	DELPHI-PACKARD	INTERNAL (MD7)			SOLENOID N (LOW SIGNAL)
NSOLI	12124639	TERMINAL, 280 SERIES SOCKET	DELPHI-PACKARD	INTERNAL (MD7)			
C3PS	12110139	CONNECTOR, 2-WAY C3PS	DELPHI-PACKARD	INTERNAL			C3 PRESSURE SWITCH
C3PS	12066337	TERMINAL, 280 SERIES PIN	DELPHI-PACKARD	INTERNAL			
OLS	12047785	CONNECTOR, 4-WAY OLS	DELPHI-PACKARD	INTERNAL			OIL LEVEL SENSOR
OLS	12047767	TERMINAL, 150F	DELPHI-PACKARD	INTERNAL			
OLS	12047664	LOCK, SECONDARY	DELPHI-PACKARD	INTERNAL			
NTI	12162723	CONNECTOR, 2-WAY	DELPHI-PACKARD	INTERNAL			TURBINE SPEED SENSOR
NTI	12110236	TERMINAL, 150F	DELPHI-PACKARD	INTERNAL			
OILT		SENSOR, TEMPERATURE, SUMP	PHILLIPS TECH	INTERNAL			
OILT, V8A	12129691	SENSOR, TEMPERATURE, SUMP	PHILLIPS TECH	INTERNAL			
TEMP, V8A	12047662	CONNECTOR, 2-WAY	DELPHI-PACKARD	INTERNAL	12129691	12129691	SENSOR, TEMPERATURE, SUMP
TEMP, V8A	12047664	LOCK, SECONDARY	DELPHI-PACKARD	INTERNAL			
TEMP, V8A	12047767	TERMINAL, SOCKET	DELPHI-PACKARD	INTERNAL			

APPENDIX E — CONNECTOR PART NUMBERS, TERMINAL PART NUMBERS, TOOL PART NUMBERS, AND REPAIR INSTRUCTIONS

CONNECTOR	MFG. P/N	PART NAME	MANUFACTURER	CONFIG	MATING P/N	MFG. P/N	MATING PART NAME
STNDMD		STANDOFF, WIRING HARNESS		INTERNAL			CONTROL MODULE, MD
STNDMD	WTA01-04-14	GROMMET, STANDOFF 14-BLOCK	DEUTSCH	INTERNAL			
STNDMD	12092195	O-RING, FEEDTHRU ASSEMBLY	DELPHI-PACKARD	INTERNAL			
STNDMD	WTA10-24-01/19	HOUSING, BACKSHELL, 24/19	DEUTSCH	INTERNAL			
STNDMD	WTA10-24-02/19	FOLLOWER, BACKSHELL, 24/19	DEUTSCH	INTERNAL			
STNDMD	WTA10-24-03	GROMMET, BACKSHELL #24	DEUTSCH	INTERNAL			
STNDMD	0810-205-0001	SEAL, FEEDTHRU ASSEMBLY	DEUTSCH	INTERNAL			CONTROL MODULE, MD/MDR OLS
STNDMR		STANDOFF, WIRING HARNESS		INTERNAL/OLS			
STNDMR	WTA01-04-12	GROMMET, STANDOFF 12-BLOCK	DEUTSCH	INTERNAL/OLS			
STNDMR	12092195	O-RING, FEEDTHRU ASSEMBLY	DELPHI-PACKARD	INTERNAL/OLS			
STNDMR	WTA10-24-01/19	HOUSING, BACKSHELL, 24/19	DEUTSCH	INTERNAL/OLS			
STNDMR	WTA10-24-02/19	FOLLOWER, BACKSHELL, 24/19	DEUTSCH	INTERNAL/OLS			
STNDMR	WTA10-24-03	GROMMET, BACKSHELL #24	DEUTSCH	INTERNAL/OLS			
STNDMR	0810-205-0001	SEAL, FEEDTHRU ASSEMBLY	DEUTSCH	INTERNAL/OLS			CONTROL MODULE, MD7
STNDM7		STANDOFF, WIRING HARNESS		INTERNAL			
STNDM7	WTA01-04-11	GROMMET, STANDOFF 11-BLOCK	DEUTSCH	INTERNAL			
STNDM7	12092195	O-RING, FEEDTHRU ASSEMBLY	DELPHI-PACKARD	INTERNAL			
STNDM7	WTA10-24-01/19	HOUSING, BACKSHELL, 24/19	DEUTSCH	INTERNAL			
STNDM7	WTA10-24-02/19	FOLLOWER, BACKSHELL, 24/19	DEUTSCH	INTERNAL			
STNDM7	WTA10-24-03	GROMMET, BACKSHELL #24	DEUTSCH	INTERNAL			
STNDM7	0810-205-0001	SEAL, FEEDTHRU ASSEMBLY	DEUTSCH	INTERNAL			CONTROL MODULE, HD
STNDHD		STANDOFF, WIRING HARNESS		INTERNAL			
STNDHD	WTA01-04-16	GROMMET, STANDOFF 16-BLOCK	DEUTSCH	INTERNAL			
STNDHD	12092195	O-RING, FEEDTHRU ASSEMBLY	DELPHI-PACKARD	INTERNAL			
STNDHD	WTA10-24-01/19	HOUSING, BACKSHELL, 24/19	DEUTSCH	INTERNAL			
STNDHD	WTA10-24-02/19	FOLLOWER, BACKSHELL, 24/19	DEUTSCH	INTERNAL			
STNDHD	WTA10-24-03	GROMMET, BACKSHELL #24	DEUTSCH	INTERNAL			
STNDHD	0810-205-0001	SEAL, FEEDTHRU ASSEMBLY	DEUTSCH	INTERNAL			CONTROL MODULE HD/HDR OLS
STNDHR		STANDOFF, WIRING HARNESS		INTERNAL/OLS			
STNDHR	WTA01-04-14	GROMMET, STANDOFF 14-BLOCK	DEUTSCH	INTERNAL/OLS			
STNDHR	12092195	O-RING, FEEDTHRU ASSEMBLY	DELPHI-PACKARD	INTERNAL/OLS			
STNDHR	WTA10-24-01/19	HOUSING, BACKSHELL, 24/19	DEUTSCH	INTERNAL/OLS			
STNDHR	WTA10-24-02/19	FOLLOWER, BACKSHELL, 24/19	DEUTSCH	INTERNAL/OLS			
STNDHR	WTA10-24-03	GROMMET, BACKSHELL #24	DEUTSCH	INTERNAL/OLS			
STNDHR	0810-205-0001	SEAL, FEEDTHRU ASSEMBLY	DEUTSCH	INTERNAL/OLS			CONTROL MODULE HD7 OLS
STNDH7		STANDOFF, WIRING HARNESS		INTERNAL			
STNDH7	WTA01-04-12	GROMMET, STANDOFF 12-BLOCK	DEUTSCH	INTERNAL			
STNDH7	12092195	O-RING, FEEDTHRU ASSEMBLY	DELPHI-PACKARD	INTERNAL			
STNDH7	WTA10-24-01/19	HOUSING, BACKSHELL, 24/19	DEUTSCH	INTERNAL			
STNDH7	WTA10-24-02/19	FOLLOWER, BACKSHELL, 24/19	DEUTSCH	INTERNAL			
STNDH7	WTA10-24-03	GROMMET, BACKSHELL #24	DEUTSCH	INTERNAL			
STNDH7	0810-205-0001	SEAL, FEEDTHRU ASSEMBLY	DEUTSCH	INTERNAL			
STNDH7	0613-1-1601	SEALING PLUG	DEUTSCH	INTERNAL			

APPENDIX E — CONNECTOR PART NUMBERS, TERMINAL PART NUMBERS, TOOL PART NUMBERS, AND REPAIR INSTRUCTIONS

CONNECTOR	MFG. P/N	PART NAME	MANUFACTURER	CONFIG	MATING P/N	MFG. P/N	MATING PART NAME
VIMX	12034397	CONNECTOR, BODY, 30-WAY	DELPHI-PACKARD	VIM WIRING			VIM HEADER
VIMX	12040879	SEAL, 15-WAY	DELPHI-PACKARD	VIM WIRING			
VIMX	12110546	STRAIN RELIEF, 30-WAY	DELPHI-PACKARD	VIM WIRING			
VIMX	12129426	BOLT, 7 mm HEAD, EXT.	DELPHI-PACKARD	VIM WIRING			
VIMX	12034236	RETAINER CLIP, BOLT	DELPHI-PACKARD	VIM WIRING			
VIMX	12103881	TERMINAL, 150F SERIES	DELPHI-PACKARD	VIM WIRING			
VIMX	12034413	CAVITY PLUG, METRI-PACK	DELPHI-PACKARD	VIM WIRING			
VIW SX	12160280	CONN 20F MIC/P 100W GRAY	DELPHI-PACKARD	VIW S WIRING	12160542	12160542	CONN 20M MIC/P 100W GRAY
VIW SX	15304882	CABLE SEAL, 14F GRAY	DELPHI-PACKARD	VIW S WIRING	12110693	12110693	CABLE SEAL, 14M GREEN
VIW SX	12191173	LOCK, SECONDARY 20F WHITE	DELPHI-PACKARD	VIW S WIRING	12191178	12191178	LOCK ASSIST/SEAL, 20M WHITE
VIW SX	12084912	TERMINAL, SOCKET 100W	DELPHI-PACKARD	VIW S WIRING	12160551	12160551	TERMINAL, PIN 100W
VIW SX	12129557	CAVITY PLUG, 100W	DELPHI-PACKARD	VIW S WIRING	12129557	12129557	CAVITY PLUG, 100W
VIW SX	12176394	CONDUIT CLIP, 13 mm BLACK	DELPHI-PACKARD	VIW S WIRING	12176394	12176394	CONDUIT CLIP, 13 mm BLACK
VIW VX	12160280	CONN 20F MIC/P 100W GRAY	DELPHI-PACKARD	VIW V WIRING	12160542	12160542	CONN 20M MIC/P 100W GRAY
VIW VX	15304882	CABLE SEAL, 14F GRAY	DELPHI-PACKARD	VIW V WIRING	12110693	12110693	CABLE SEAL, 14M GREEN
VIW VX	12191172	LOCK, SECONDARY 20F BLUE	DELPHI-PACKARD	VIW V WIRING	12191177	12191177	LOCK ASSIST/SEAL, 20M BLUE
VIW VX	12084912	TERMINAL, SOCKET 100W	DELPHI-PACKARD	VIW V WIRING	12160551	12160551	TERMINAL, PIN 100W
VIW VX	12129557	CAVITY PLUG, 100W	DELPHI-PACKARD	VIW V WIRING	12129557	12129557	CAVITY PLUG, 100W
VIW VX	12176394	CONDUIT CLIP, 13 mm BLACK	DELPHI-PACKARD	VIW V WIRING	12176394	12176394	CONDUIT CLIP, 13 mm BLACK

APPENDIX E — CONNECTOR PART NUMBERS, TERMINAL PART NUMBERS, TOOL PART NUMBERS, AND REPAIR INSTRUCTIONS

NOTES

APPENDIX F — THROTTLE POSITION SENSOR ADJUSTMENT

A. Description of Operation (Figure F-1)

1. To properly communicate throttle position to the Electronic Control Unit (ECU), the throttle position sensor must convert its mechanical movement to an electrical form the ECU can understand. To accomplish this, contacts move across a resistive strip inside the sensor which translates position into voltage.

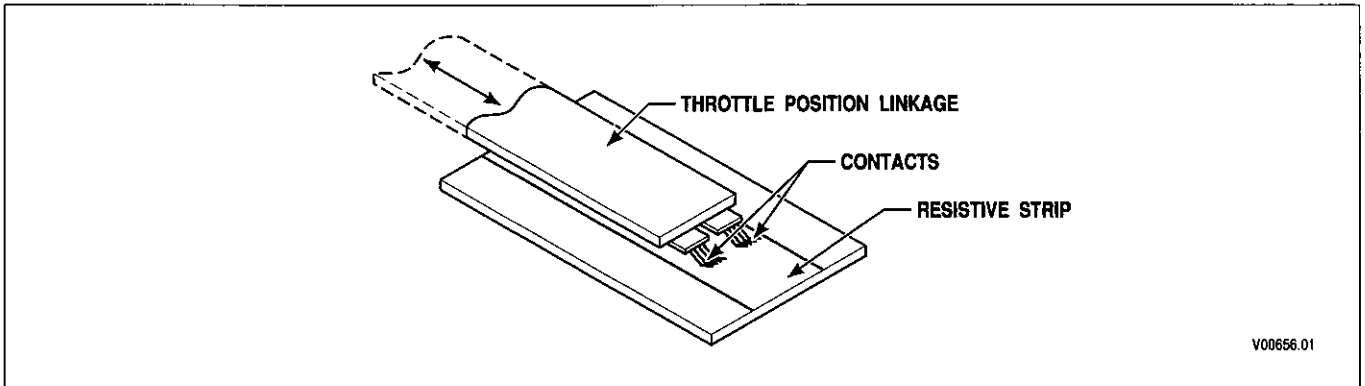

Figure F-1. Throttle Position to Voltage Conversion

2. Each position gives a different voltage. The ECU then converts the voltage to counts. Each count corresponds to approximately 0.179 mm (0.007 inch) of throttle sensor movement. Figure F-2 diagrams the counts and throttle movement relationship.

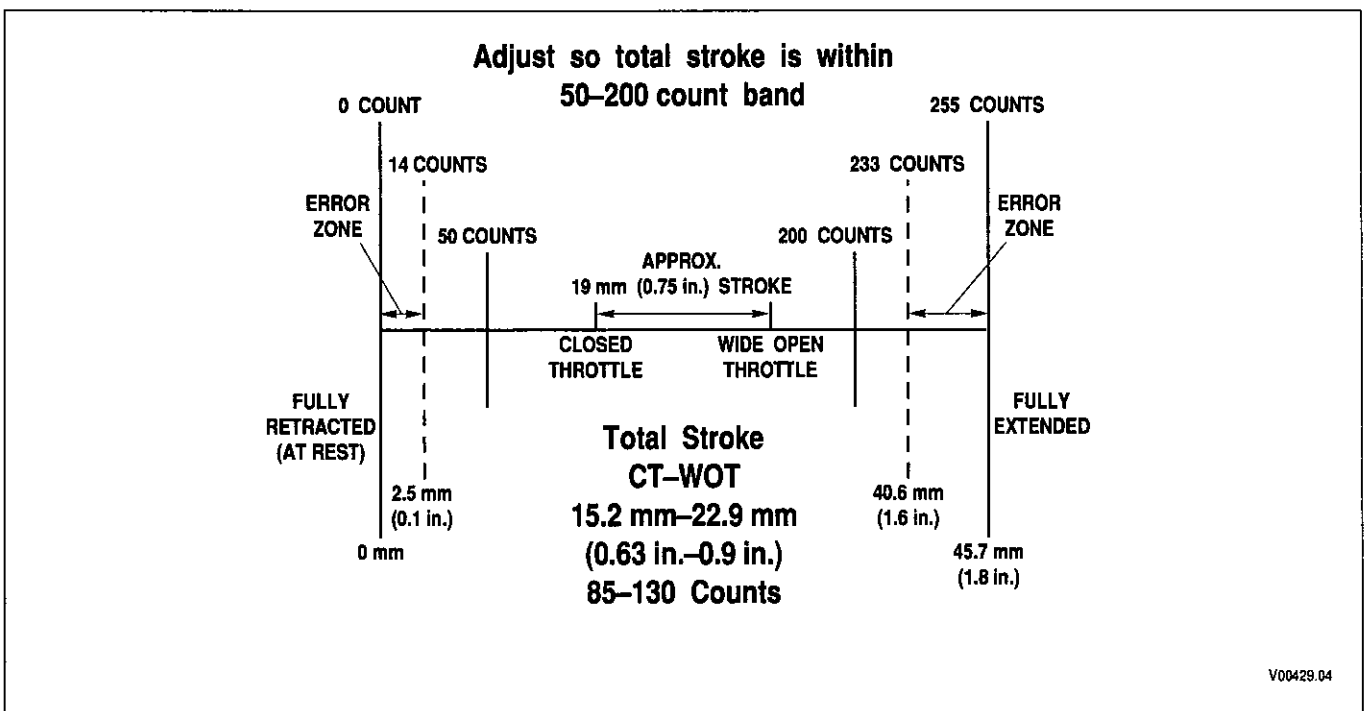

Figure F-2. Throttle Position Determination Diagram

3. Throttle percentage is proportional to counts; low counts correspond to low percent and high counts correspond to high percent (Table F-1, Page F-3).
4. The conversion from counts to percent throttle is performed easily once the idle and full throttle positions are set (see adjustment procedures below). The idle and full throttle positions correspond

APPENDIX F — THROTTLE POSITION SENSOR ADJUSTMENT

to counts which can be viewed with a diagnostic tool. The ECU determines percent throttle by the equation:

$$\% \text{ Throttle} = \frac{\text{Current Count} - \text{Idle Count}}{\text{Full Throttle Count} - \text{Idle Count}} \times 100$$

Where:

Idle Count = Count on diagnostic tool when engine is idling.

Current Count = Count on diagnostic tool at the present throttle position.

Full Throttle Count = Count on diagnostic tool at wide open throttle.

NOTE: Refer to Appendix N for DDR information.

- The throttle position sensor is self-calibrating within its normal operating range. Each time the vehicle is started and the ECU is initialized, the idle counts that are used for closed throttle are increased by 15 counts from its previous lowest reading. Also, the wide open throttle counts are reduced by 15 counts from its previous highest reading. Once new counts are read from the current sensor position, the idle and wide open throttle count set points are continually readjusted to the lowest and highest counts, respectively. This compensates for fuel control system wear or previous mechanical adjustment. One area of particular concern is when the throttle sensor extends into the error zone. This indicates a TPS misadjustment to the ECU and 100 percent throttle is assumed until readjustment is performed. Simply clearing the code 21 XX will not resolve the 100 percent (WOT) shifting situation.

NOTE: After replacing or adjusting the throttle position sensor linkage, the technician should use the diagnostic tool to clear the throttle calibration. Go to the DDR selection menu and locate ACTION REQUESTS. Select RESET THROTTLE CALIBRATION and ENTER to set the 0 percent throttle counts. After the idle counts are established, the throttle should be moved to the Full position to establish the full or Wide Open Throttle (WOT) position (100 percent). The full throttle counts will be the same as the idle counts until the throttle is moved. The full throttle counts are set when maximum travel is reached so stopping before actual full throttle will set the 100 percent point artificially low. Refer to Figure F-2 for proper counts and percentage. Refer to Figure F-3 for illustration of throttle position adjustment.

B. Throttle Position Sensor (TPS) Adjustment

When properly installed by the equipment manufacturer, the TPS should not require adjustment. Confirm that the throttle sensor is installed to manufacturer specifications before adjusting the throttle position sensor. The idle count should be 50 or higher and full throttle count 200 or lower. The TPS is self-calibrating meaning there is no optimum closed throttle or wide open throttle count value. As long as the counts are within the 50 to 200 range, the TPS is set properly. Total stroke of 85–130 counts must be maintained. Watch the movement of the throttle sensor as the controls move it through its full stroke. Be sure there is no misalignment or obstruction to smooth movement through the full stroke. Make certain the idle and full throttle positions are not in the error zones (refer to Figure F-2). The error zones occur when the idle position is less than 14 counts, or when the full throttle position is more than 233 counts. When idle or wide open throttle positions are in the error zones, codes 21 12 and 21 23 occur, respectively. These codes cause the transmission to shift as if the throttle is fully depressed (100 percent throttle) affecting shift quality and causing decreased fuel efficiency. Code 21 XX may be caused by a short or open circuit in the chassis harness or by incorrect voltages. If this occurs, refer to Code 21 XX chart.

NOTE: Use Test Harness J 41339 for measuring voltages.

APPENDIX F — THROTTLE POSITION SENSOR ADJUSTMENT

Table F-1. Volts Versus Count for Throttle Sensor Display Reading

CTS	Volts	CTS	Volts	CTS	Volts	CTS	Volts	CTS	Volts	CTS	Volts
0	0	41		81		121		161		201	
1	0.0196	42		82		122		162		202	
2		43		83		123		163		203	
3		44		84		124		164		204	
4		45	0.882	85	1.666	125	2.451	165	3.235	205	4.019
5	0.098	46		86		126		166		206	
6		47		87		127		167		207	
7		48		88		128		168		208	
8		49		89		129		169		209	
9		50	0.98	90	1.764	130	2.549	170	3.333	210	4.117
10	0.196	51		91		131		171		211	
11		52		92		132		172		212	
12		53		93		133		173		213	
13		54		94		134		174		214	
14		55	1.078	95	1.863	135	2.647	175	3.431	215	4.215
15	0.276	56		96		136		176		216	
16		57		97		137		177		217	
17		58		98		138		178		218	
18		59		99		139		179		219	
19		60	1.176	100	1.96	140	2.745	180	3.529	220	4.313
20	0.392	61		101		141		181		221	
21		62		102		142		182		222	
22		63		103		143		183		223	
23		64		104		144		184		224	
24		65	1.274	105	2.058	145	2.843	185	3.627	225	4.411
25	0.49	66		106		146		186		226	
26		67		107		147		187		227	
27		68		108		148		188		228	
28		69		109		149		189		229	
29		70	1.372	110	2.156	150	2.941	190	3.725	230	4.509
30	0.588	71		111		151		191		231	
31		72		112		152		192		232	
32		73		113		153		193		233	
33		74		114		154		194		234	
34		75	1.47	115	2.225	155	3.039	195	3.823	235	4.607
35	0.686	76		116		156		196		236	
36		77		117		157		197		237	
37		78		118		158		198		238	
38		79		119		159		199		239	
39		80	1.568	120	2.353	160	3.137	200	3.921	240	4.705
40	0.784										

APPENDIX F — THROTTLE POSITION SENSOR ADJUSTMENT

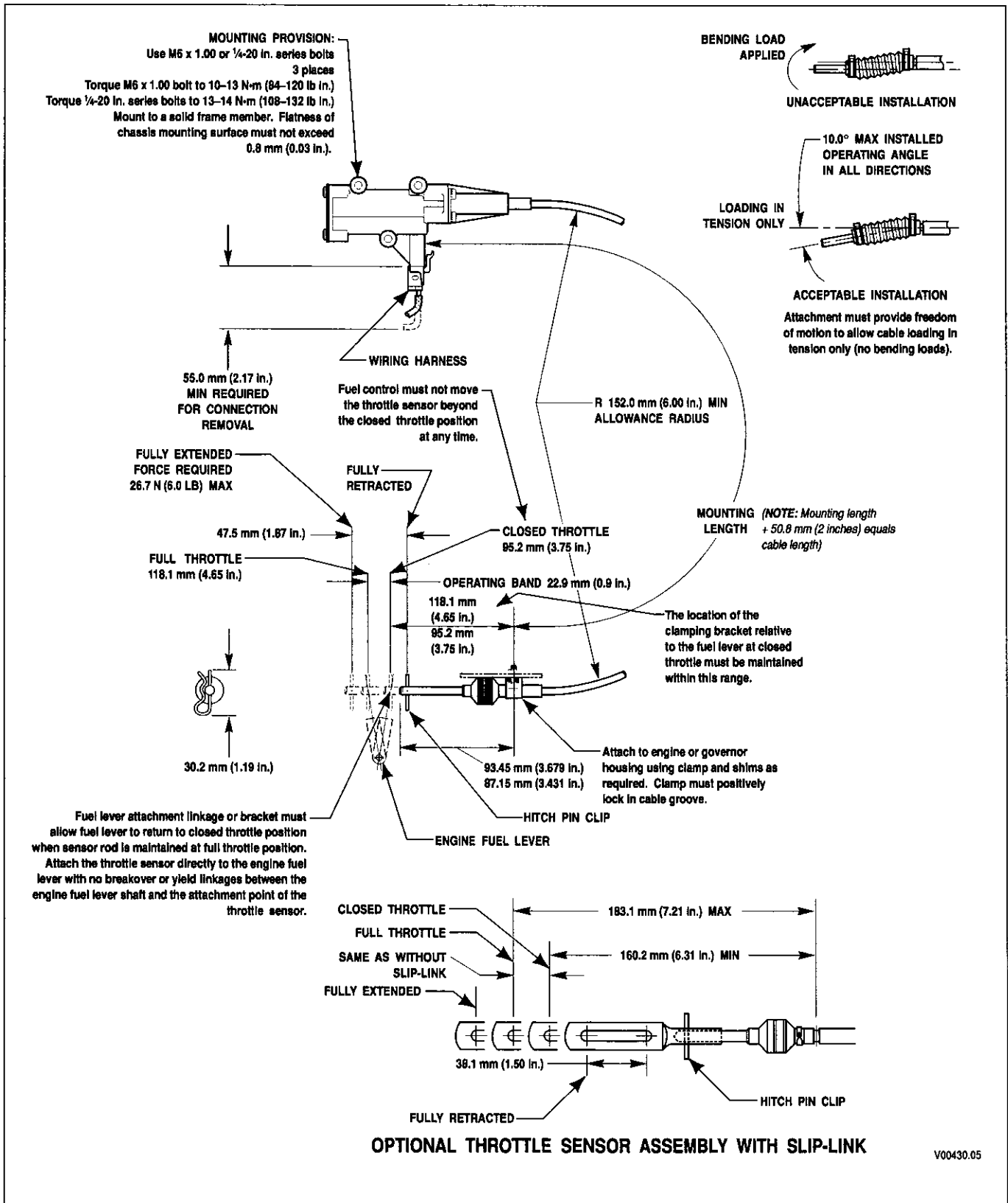

V00430.05

Figure F-3. Throttle Position Sensor Adjustment

APPENDIX G — WELDING ON VEHICLE/VEHICLE INTERFACE MODULE

1-1. WELDING ON VEHICLE

When frame or other welding is required on the vehicle, take the following precautions to protect the electronic control components:

1. Disconnect the wiring harness connectors at the transmission electronic control unit.
2. Disconnect the positive and negative battery connections, and any electronic control ground wires connected to the frame or chassis.
3. Cover electronic control components and wiring to protect them from hot sparks, etc.
4. Do not connect welding cables to electronic control components.

WARNING!

Do not jump start a vehicle with arc welding equipment. Arc welding equipment's dangerously high currents and voltages cannot be reduced to safe levels.

1-2. VEHICLE INTERFACE MODULE

The Allison Vehicle Interface Module (VIM) containing all Allison system relays and fuses must be used as the interface to all vehicle wiring. Refer to Figure G-2 for VIM component location and pin-out. To close an open VIM, tighten the bolts in the numerical order shown in Figure G-1 to provide a sealed, water-tight box. Torque the bolts to 5-8 N·m (4-6 lb ft).

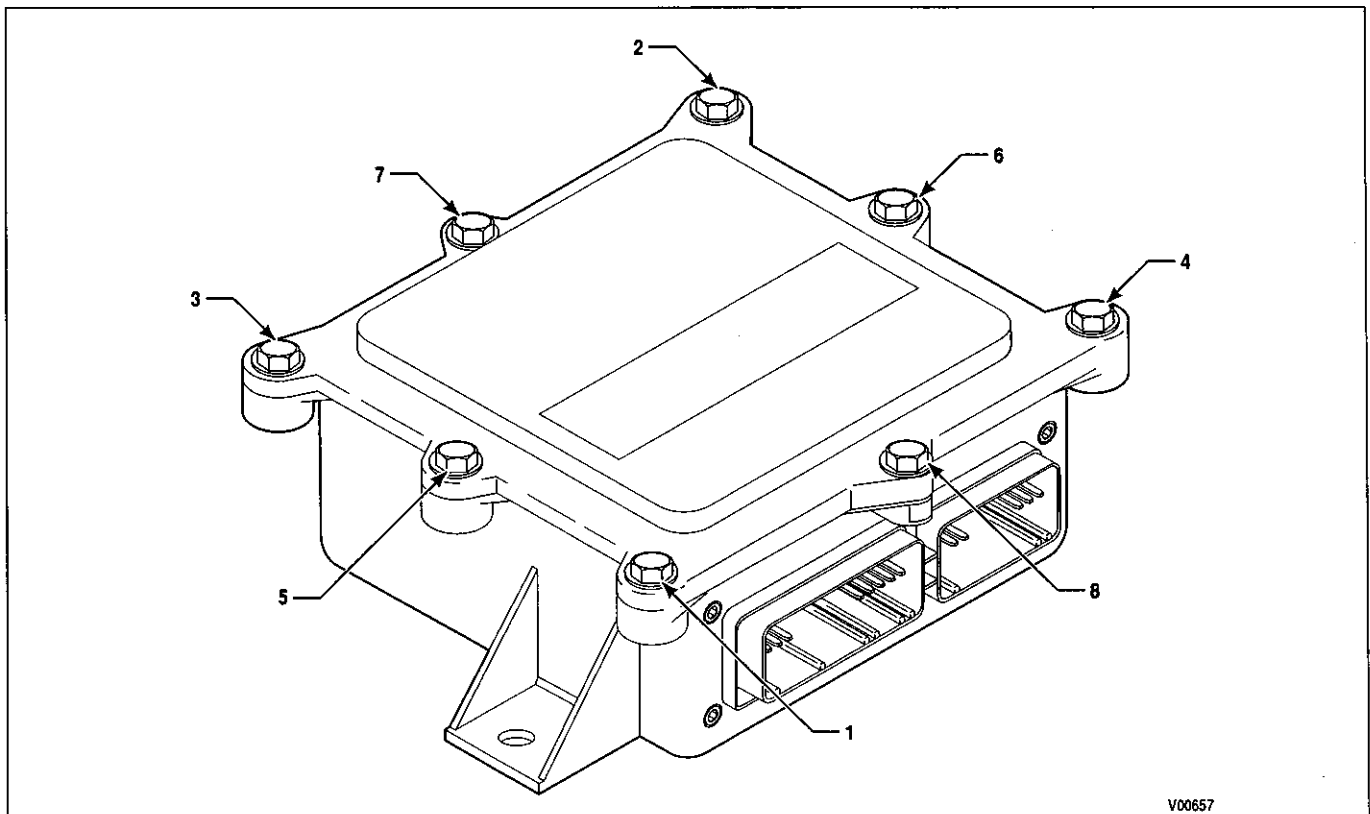
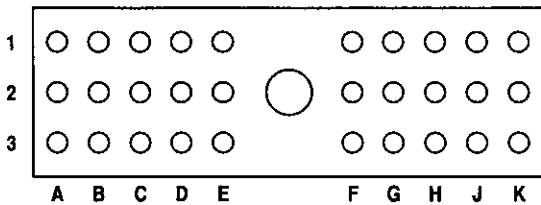
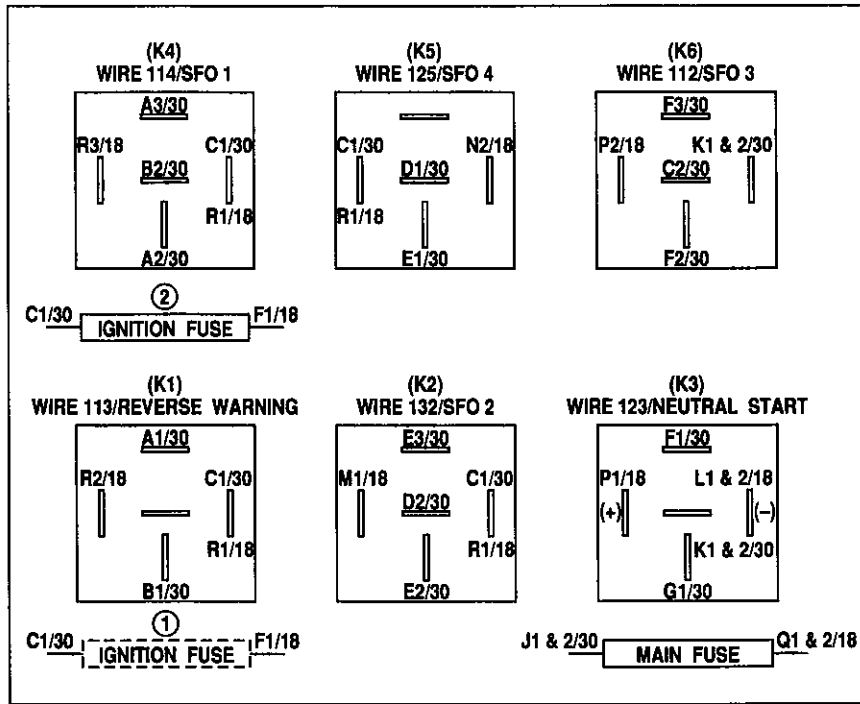
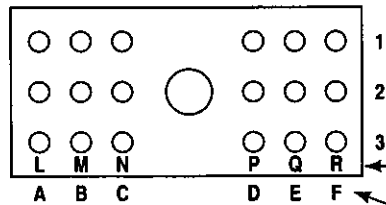

Figure G-1. Vehicle Interface Module

APPENDIX G — WELDING ON VEHICLE/VEHICLE INTERFACE MODULE



30-WAY CONNECTOR (PIN ID/30)
See page D-26 for wire/terminal usage.



18-WAY CONNECTOR (PIN ID/18)
See page D-25 for wire/terminal usage.

TERMINAL BOARD IDENTIFICATION
HARNESS CONNECTOR IDENTIFICATION

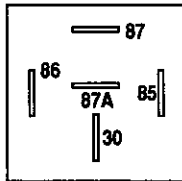

Pin numbering on bottom of relay

- ① Ignition fuse position in early VIM
- ② Ignition fuse must be in place and not open for there to be continuity between pins C1/30 and R1/18

Figure G-2. VIM Components Location and Pin-Out Diagram

APPENDIX H — HYDRAULIC SCHEMATICS

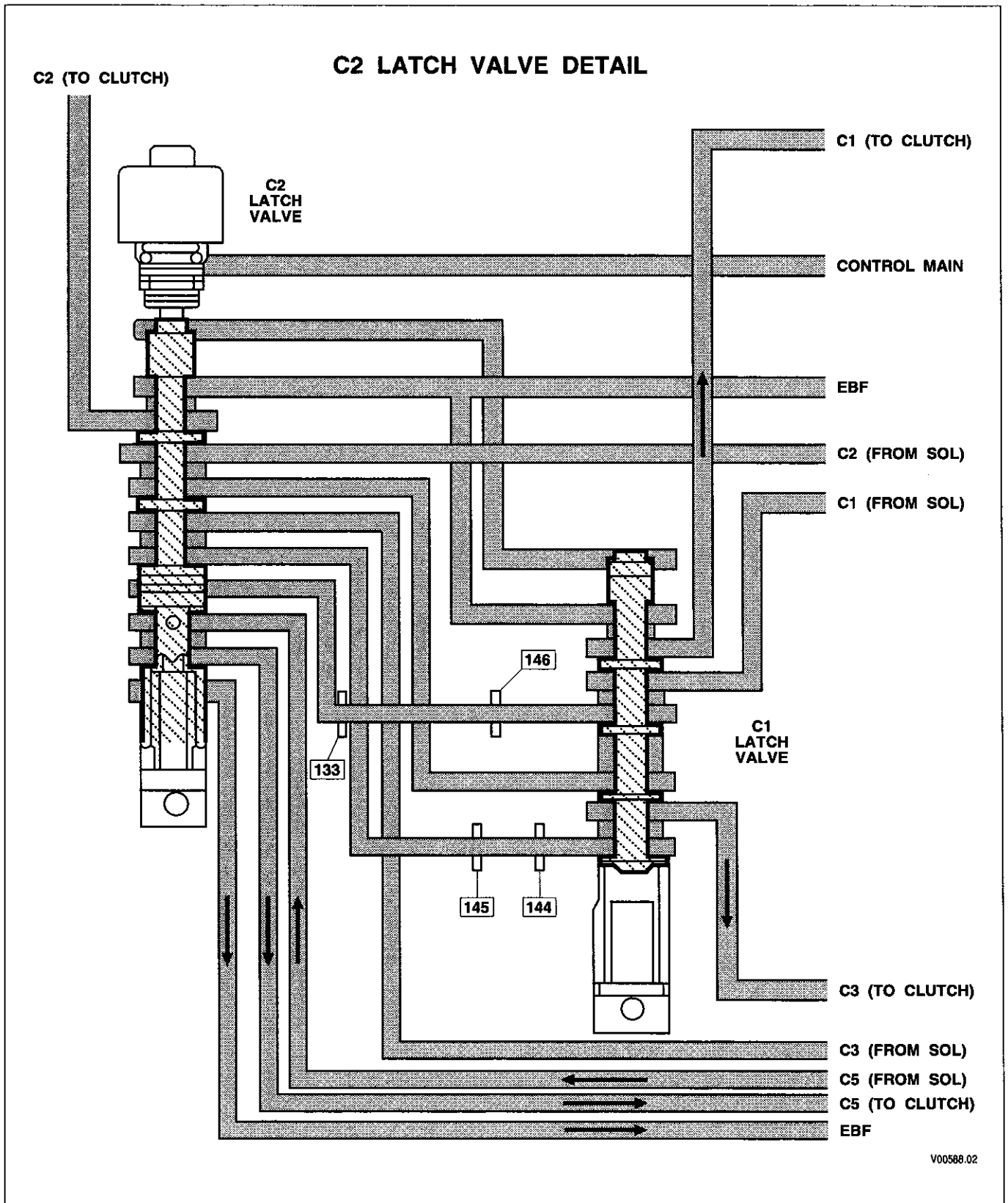

Figure H-1. C2 Latch Valve Detail

APPENDIX H — HYDRAULIC SCHEMATICS

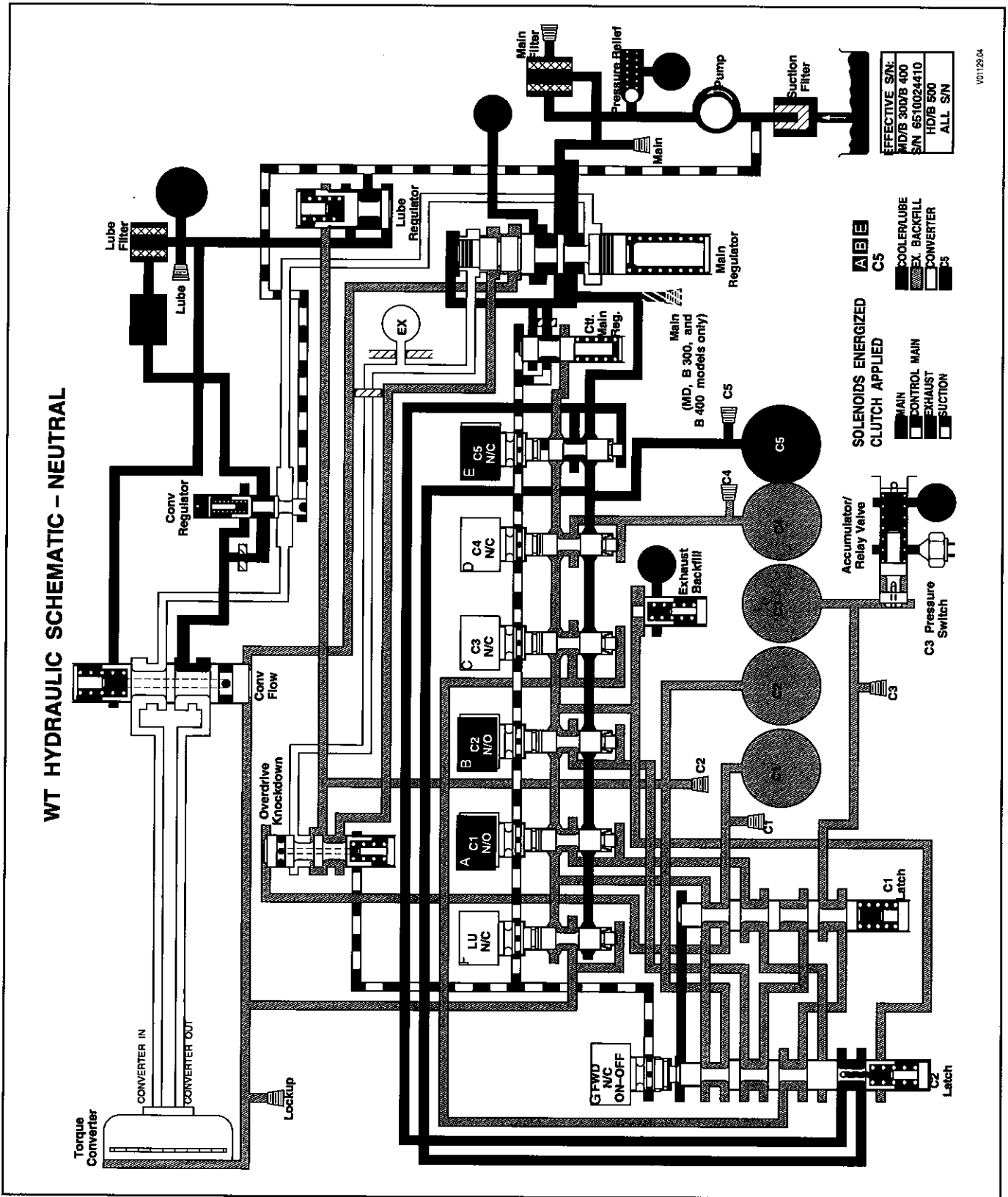

Figure H-2. WT Hydraulic Schematic — Neutral

APPENDIX H — HYDRAULIC SCHEMATICS

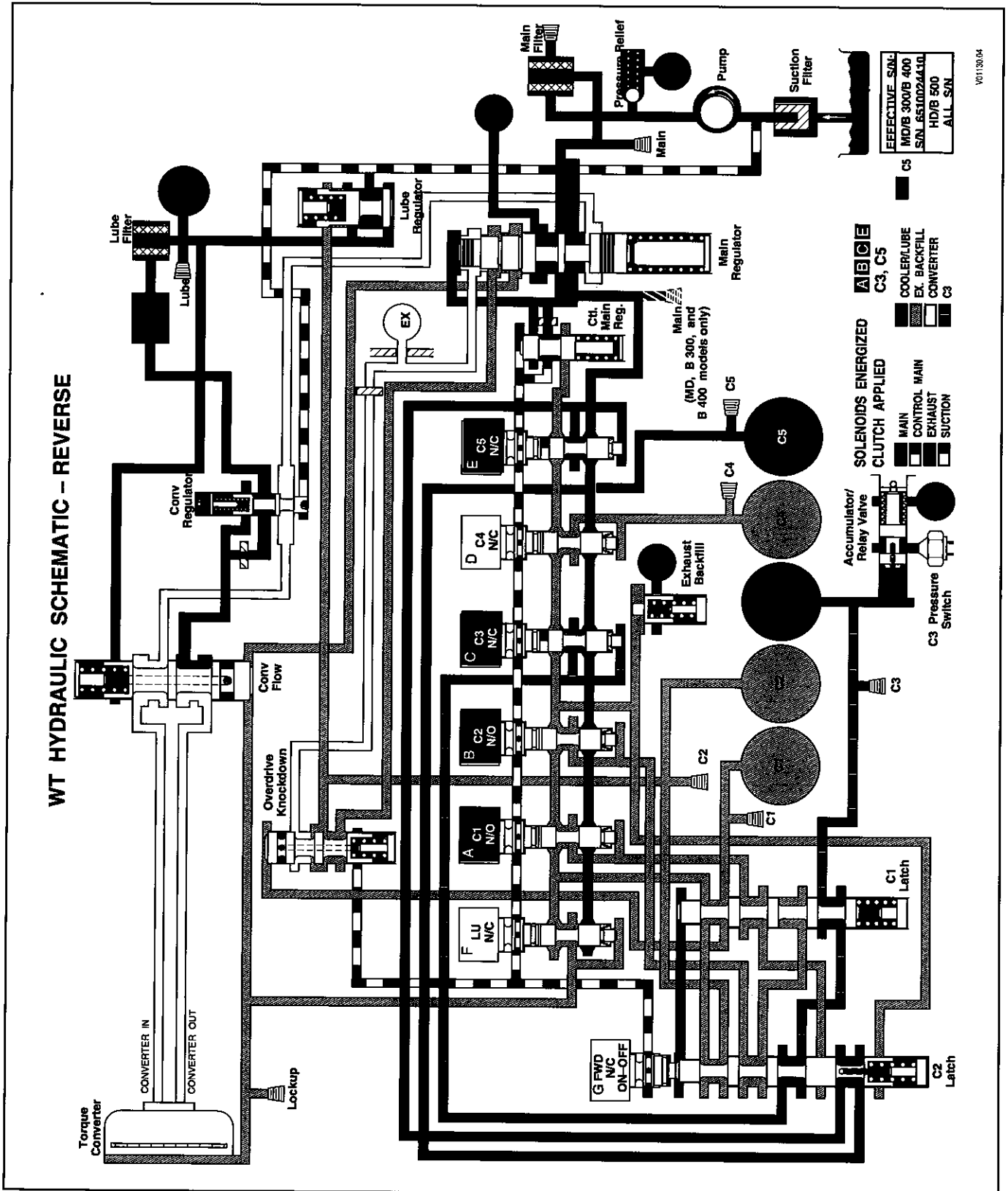

Figure H-3. WT Hydraulic Schematic — Reverse

APPENDIX H — HYDRAULIC SCHEMATICS

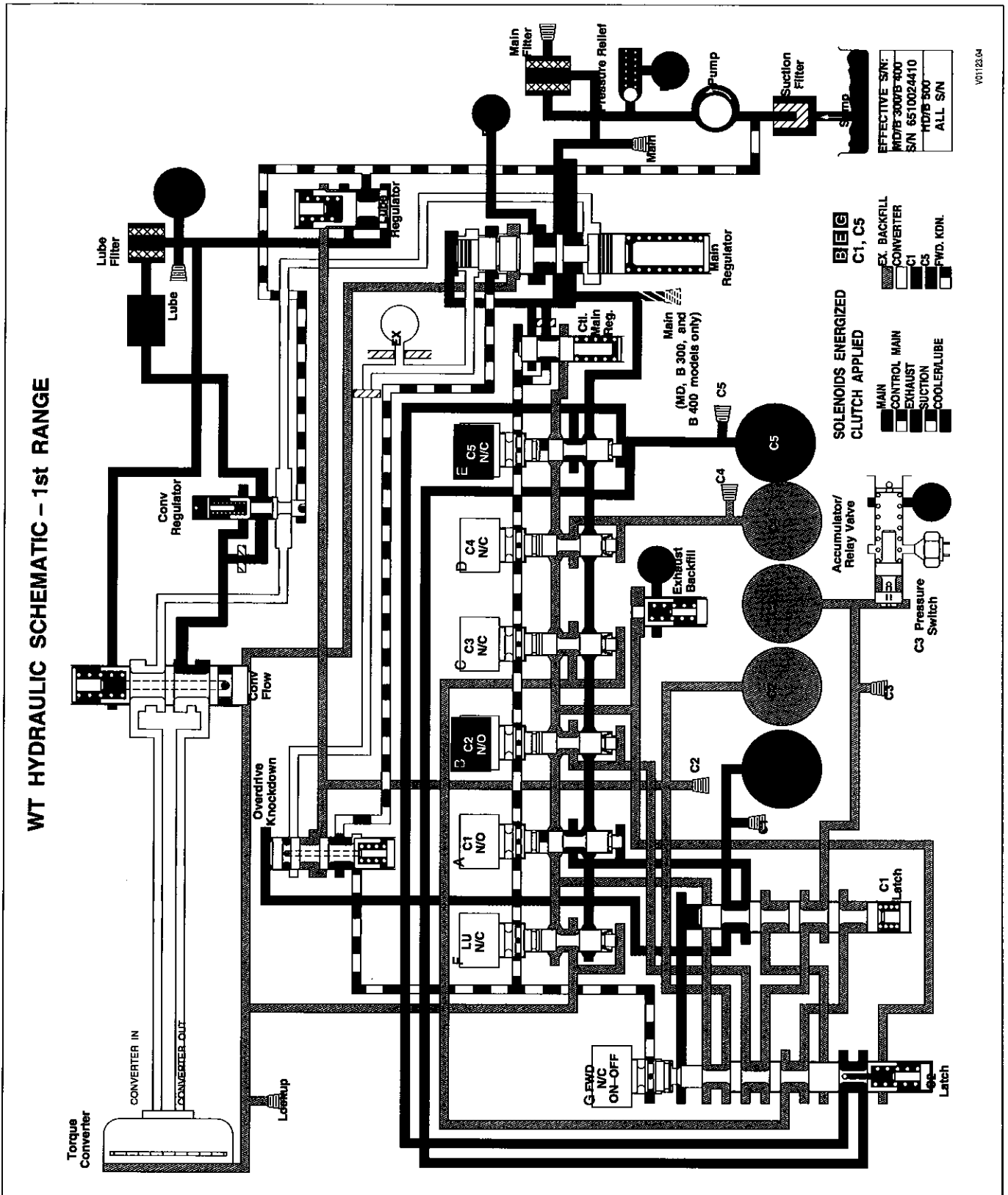

Figure H-4. WT Hydraulic Schematic — 1st Range

APPENDIX H — HYDRAULIC SCHEMATICS

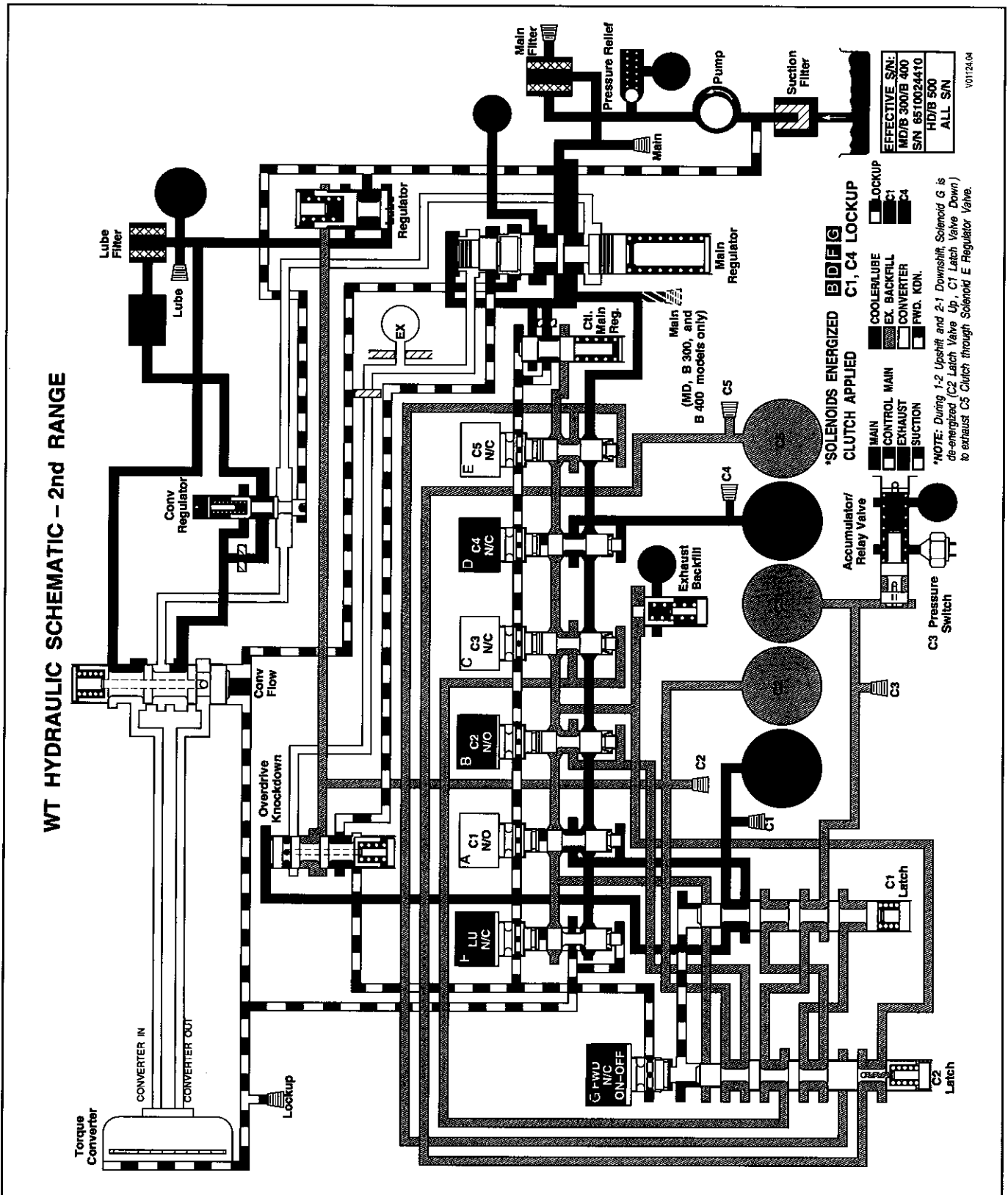

Figure H-5. WT Hydraulic Schematic — 2nd Range

APPENDIX H — HYDRAULIC SCHEMATICS

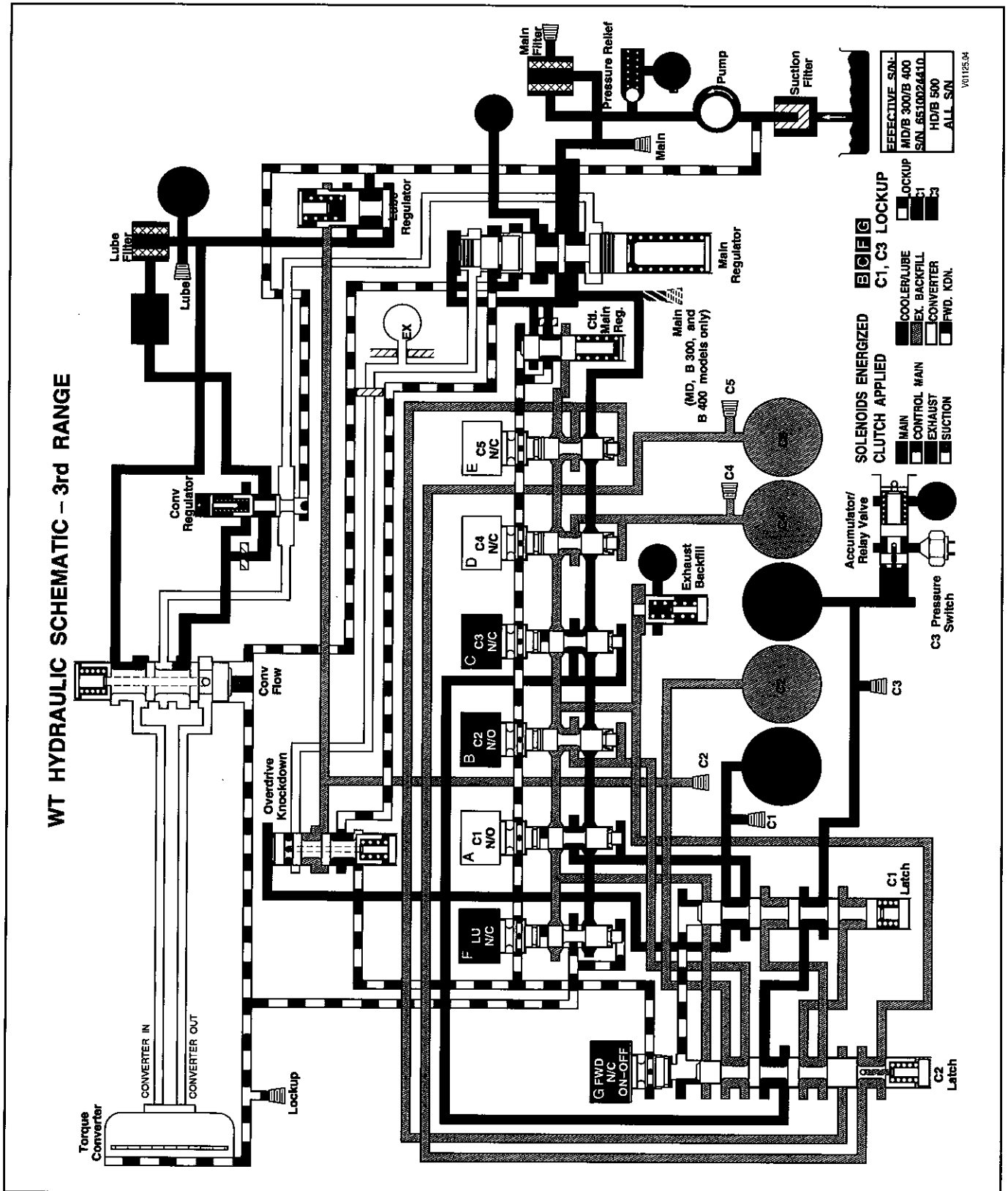

Figure H-6. WT Hydraulic Schematic — 3rd Range

APPENDIX H — HYDRAULIC SCHEMATICS

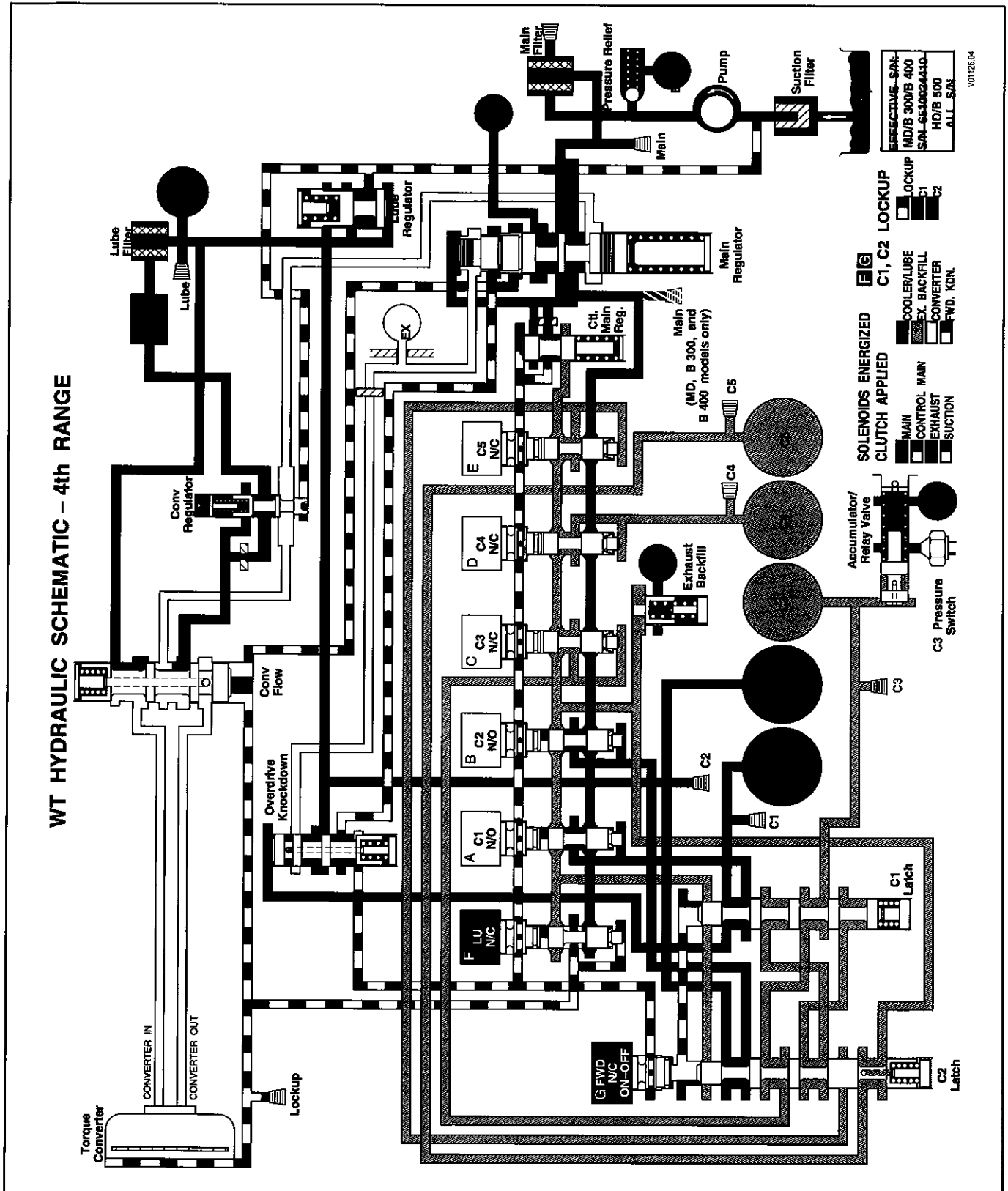

Figure H-7. WT Hydraulic Schematic — 4th Range

APPENDIX H — HYDRAULIC SCHEMATICS

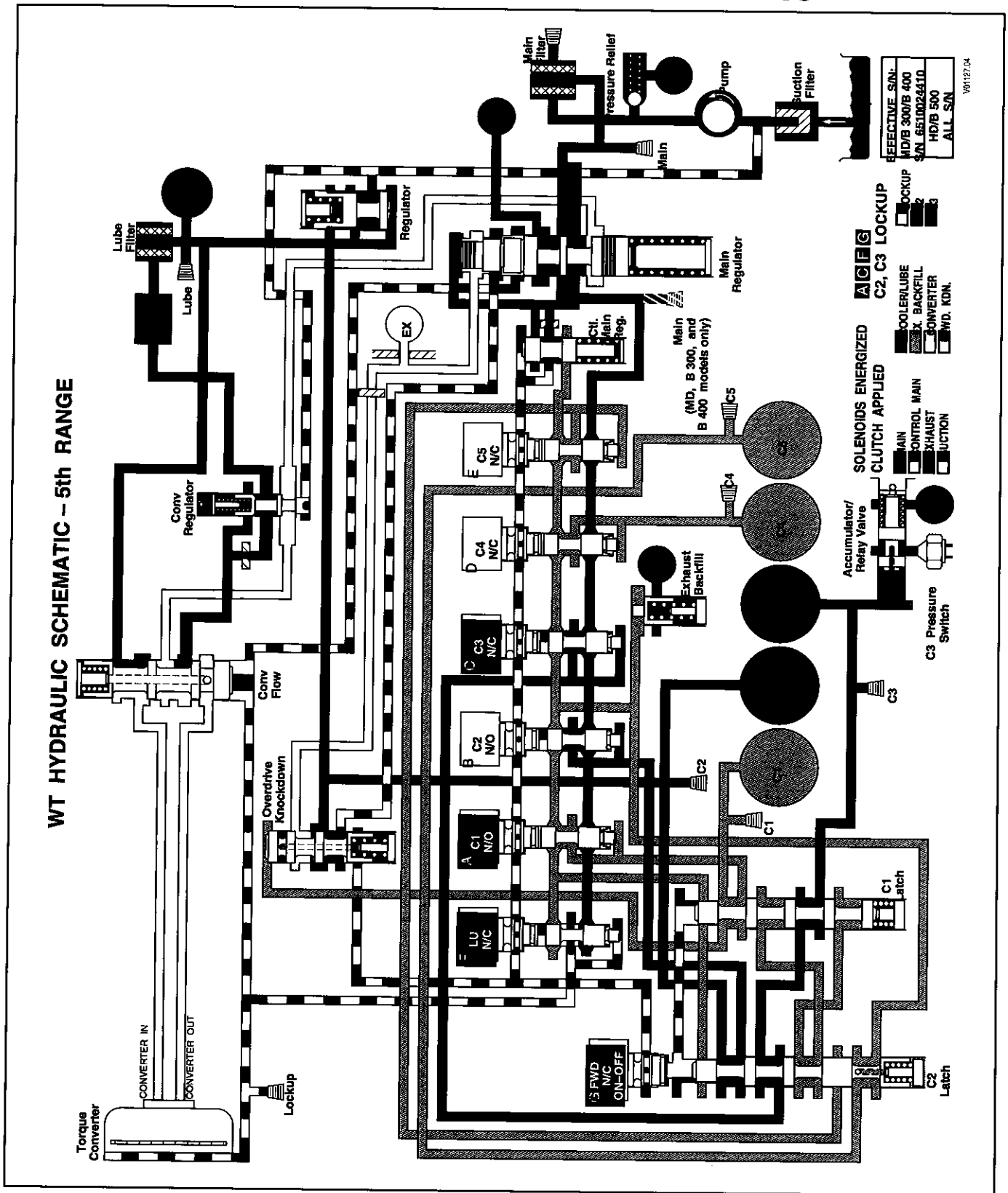

Figure H-8. WT Hydraulic Schematic — 5th Range

APPENDIX H — HYDRAULIC SCHEMATICS

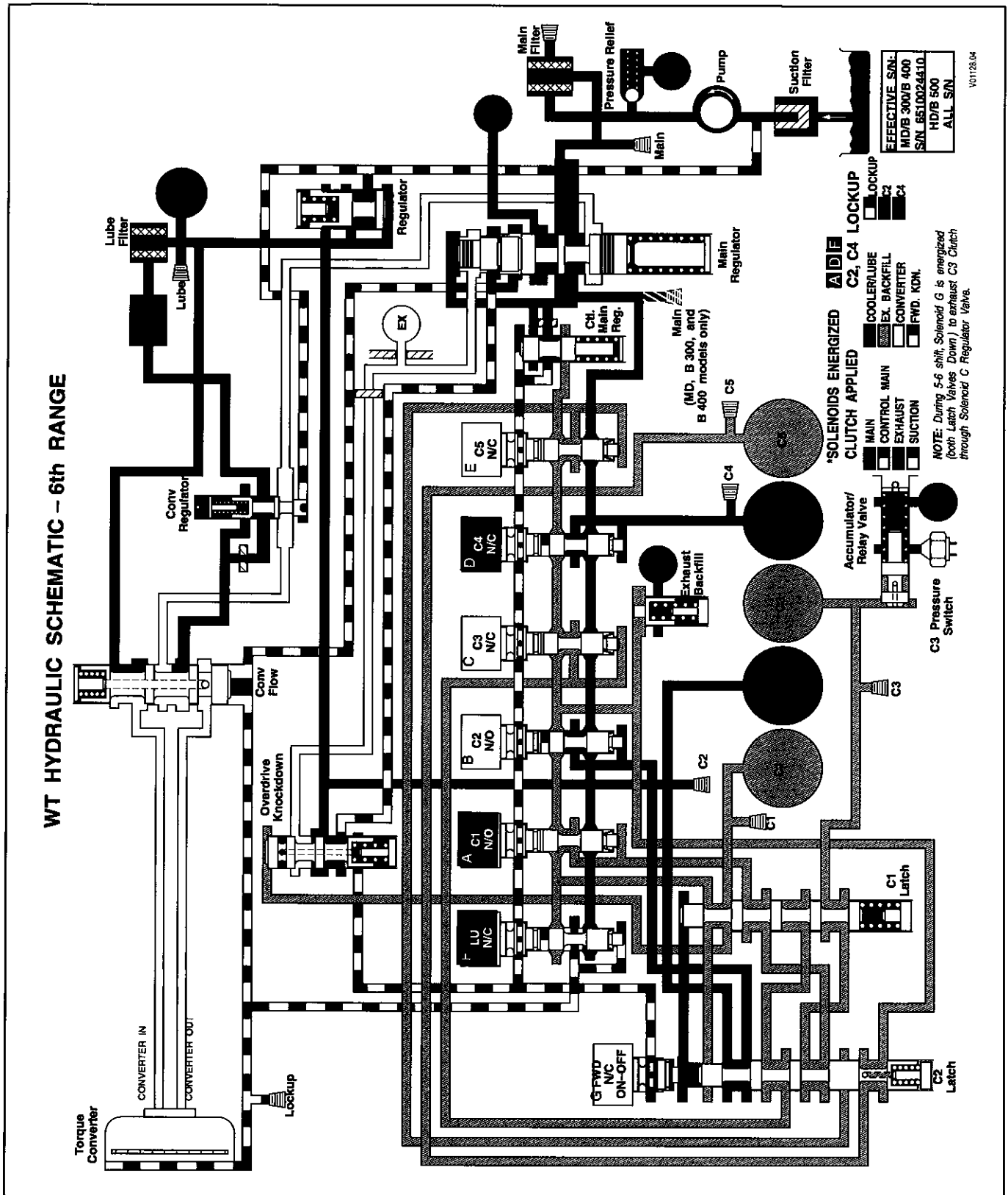
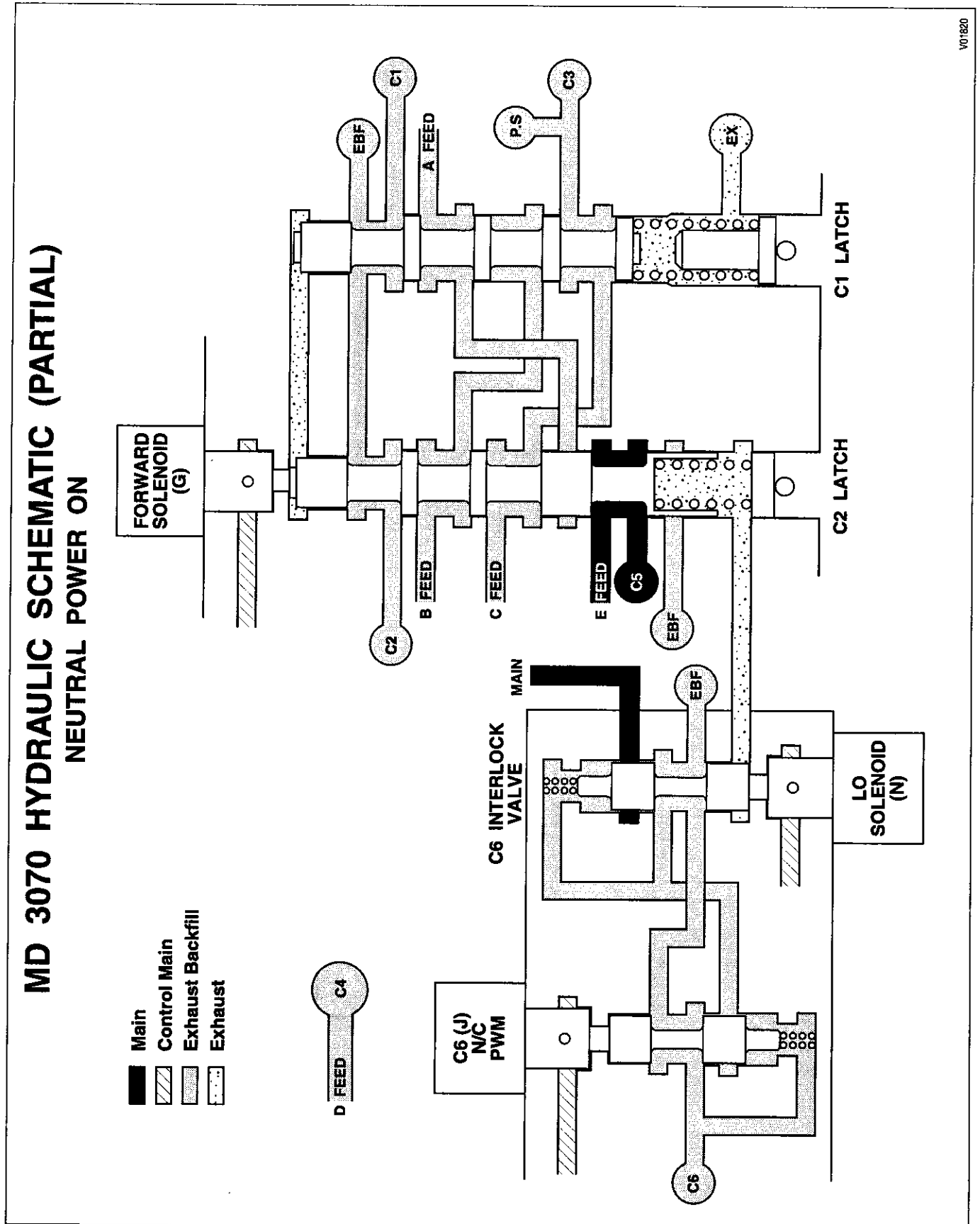

Figure H-9. WT Hydraulic Schematic — 6th Range

APPENDIX H — HYDRAULIC SCHEMATICS



101820

Figure H-10. MD 3070 Hydraulic Schematic — Neutral Power On

APPENDIX H — HYDRAULIC SCHEMATICS

MD 3070 HYDRAULIC SCHEMATIC (PARTIAL)
REVERSE POWER ON

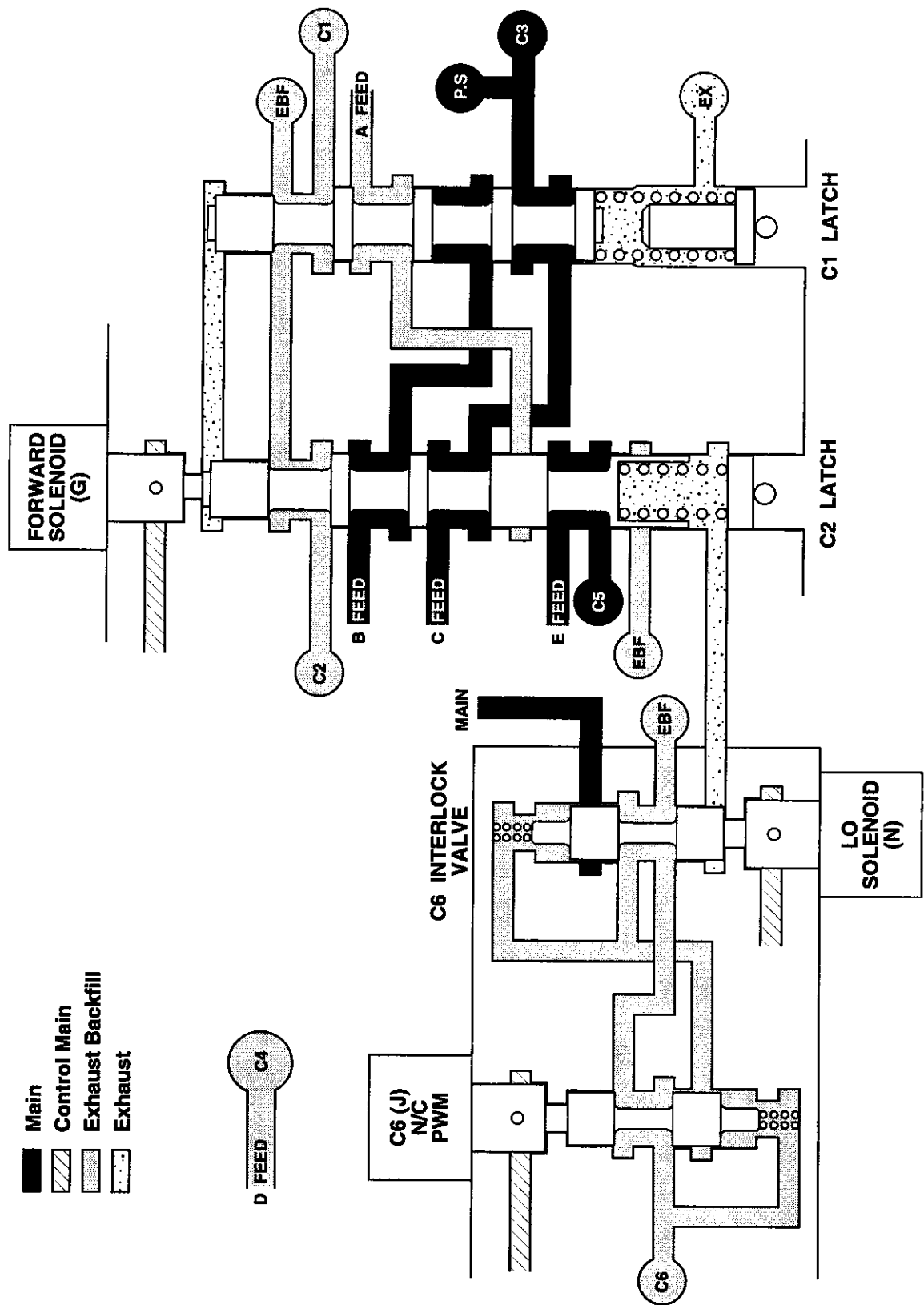

V01821

Figure H-11. MD 3070 Hydraulic Schematic — Reverse Power On

APPENDIX H — HYDRAULIC SCHEMATICS

V01822

MD 3070 HYDRAULIC SCHEMATIC (PARTIAL)
LO MD POWER ON

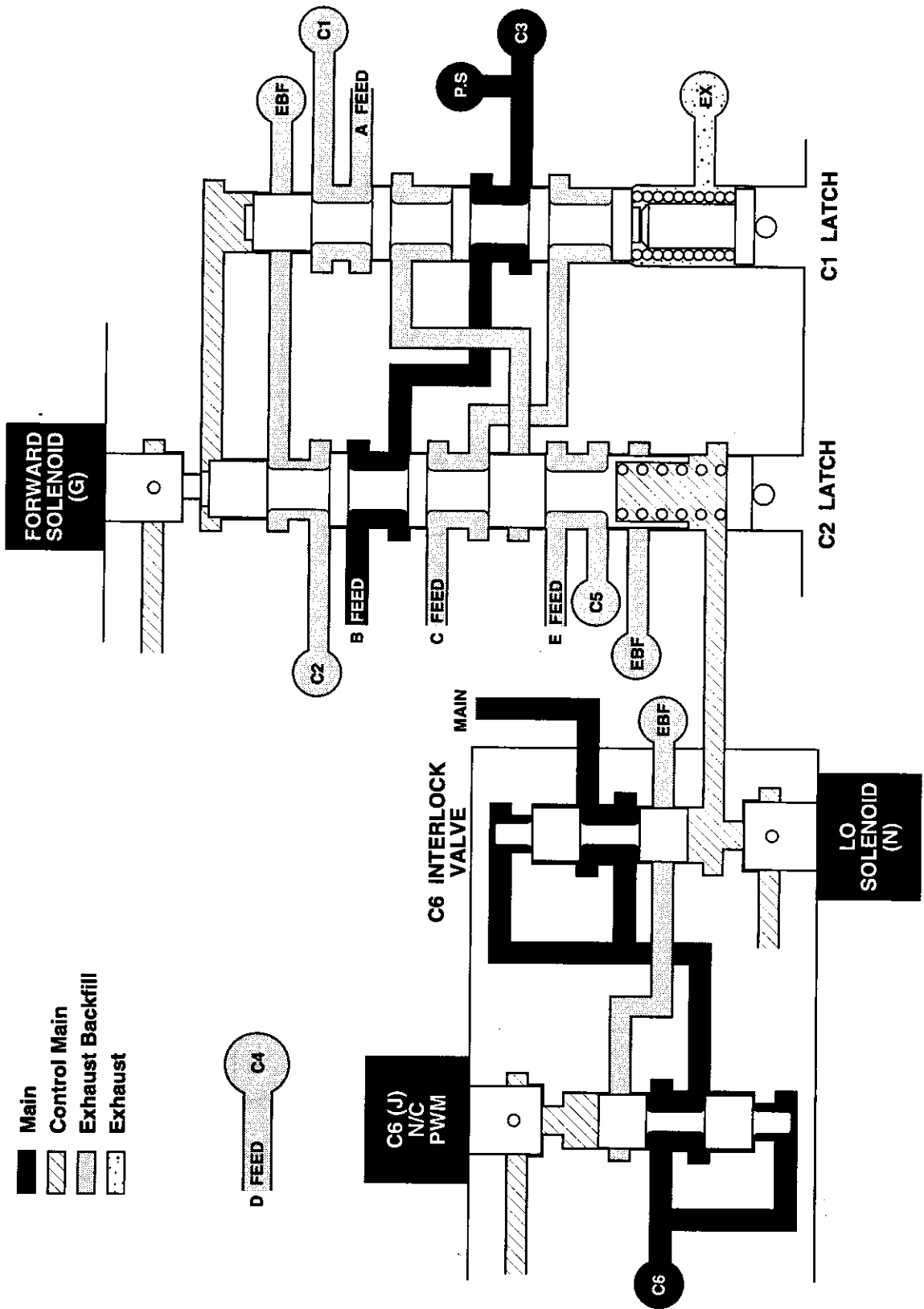
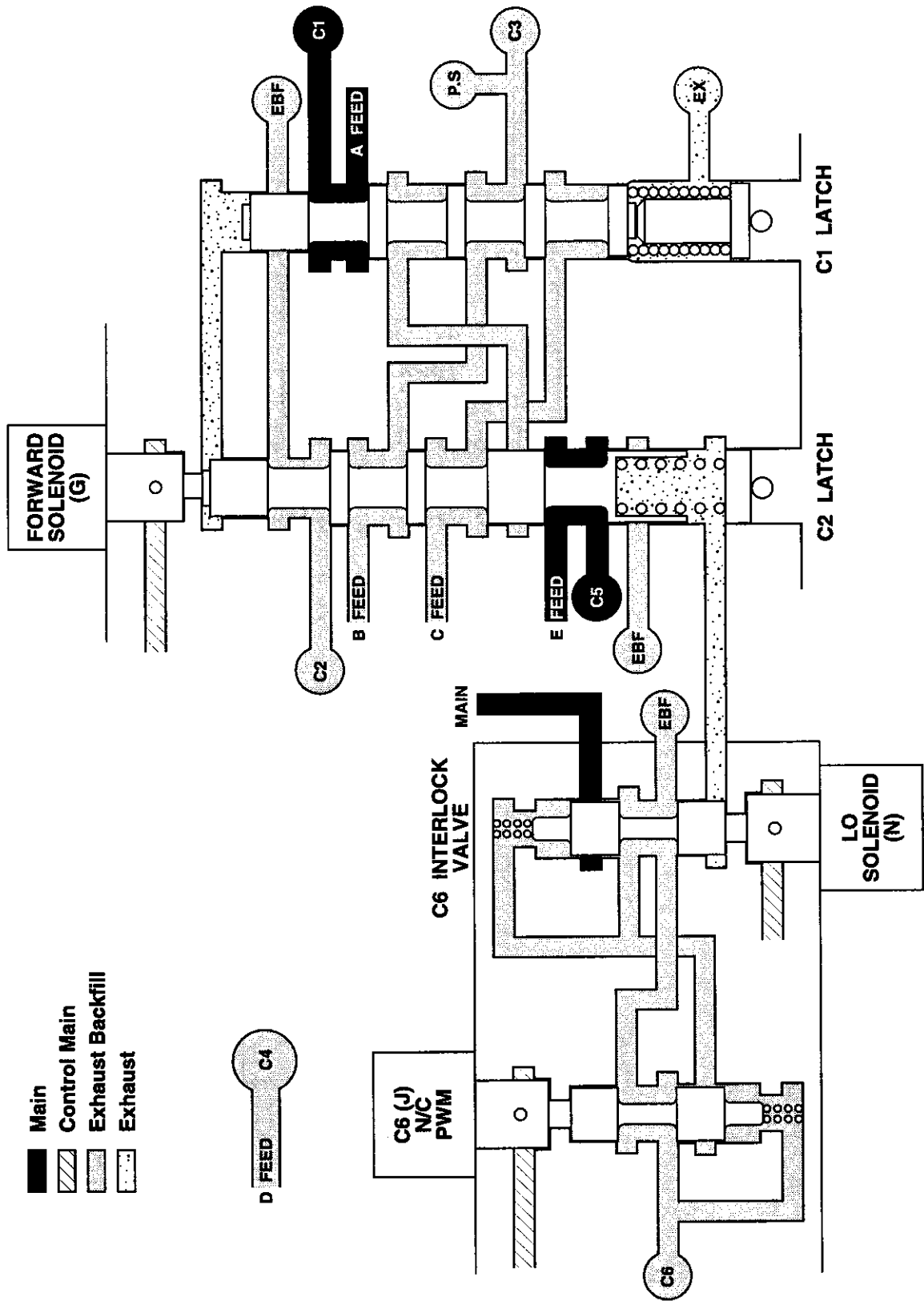

Figure H-12. MD 3070 Hydraulic Schematic — Lo MD Power On

APPENDIX H — HYDRAULIC SCHEMATICS

MD 3070 HYDRAULIC SCHEMATIC (PARTIAL)

1ST POWER ON



V01623

Figure H-13. MD 3070 Hydraulic Schematic — 1st Power On

APPENDIX H — HYDRAULIC SCHEMATICS

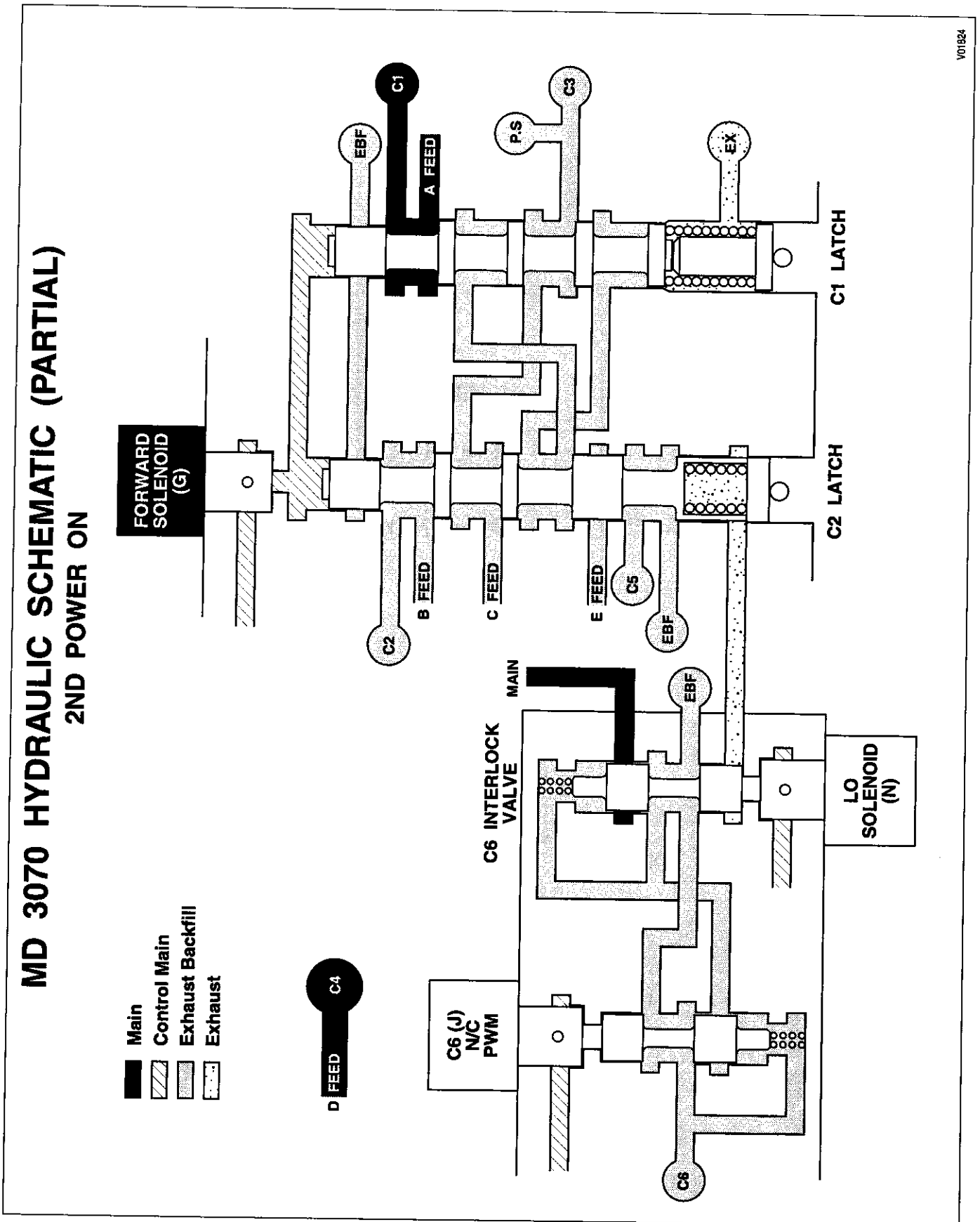
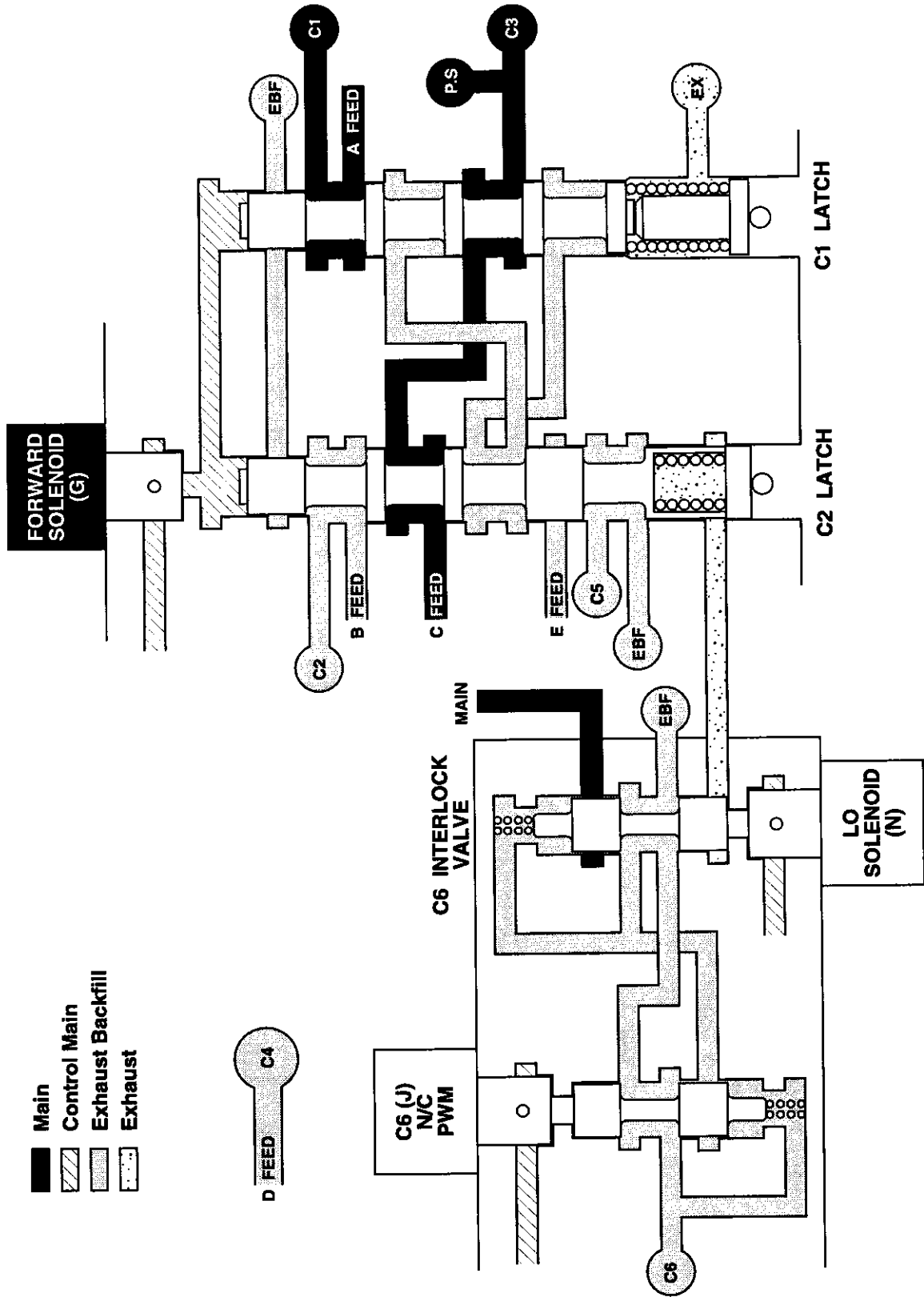

Figure H-14. MD 3070 Hydraulic Schematic — 2nd Power On

APPENDIX H — HYDRAULIC SCHEMATICS

MD 3070 HYDRAULIC SCHEMATIC (PARTIAL)
3RD POWER ON



VD1825

Figure H-15. MD 3070 Hydraulic Schematic — 3rd Power On

APPENDIX H — HYDRAULIC SCHEMATICS

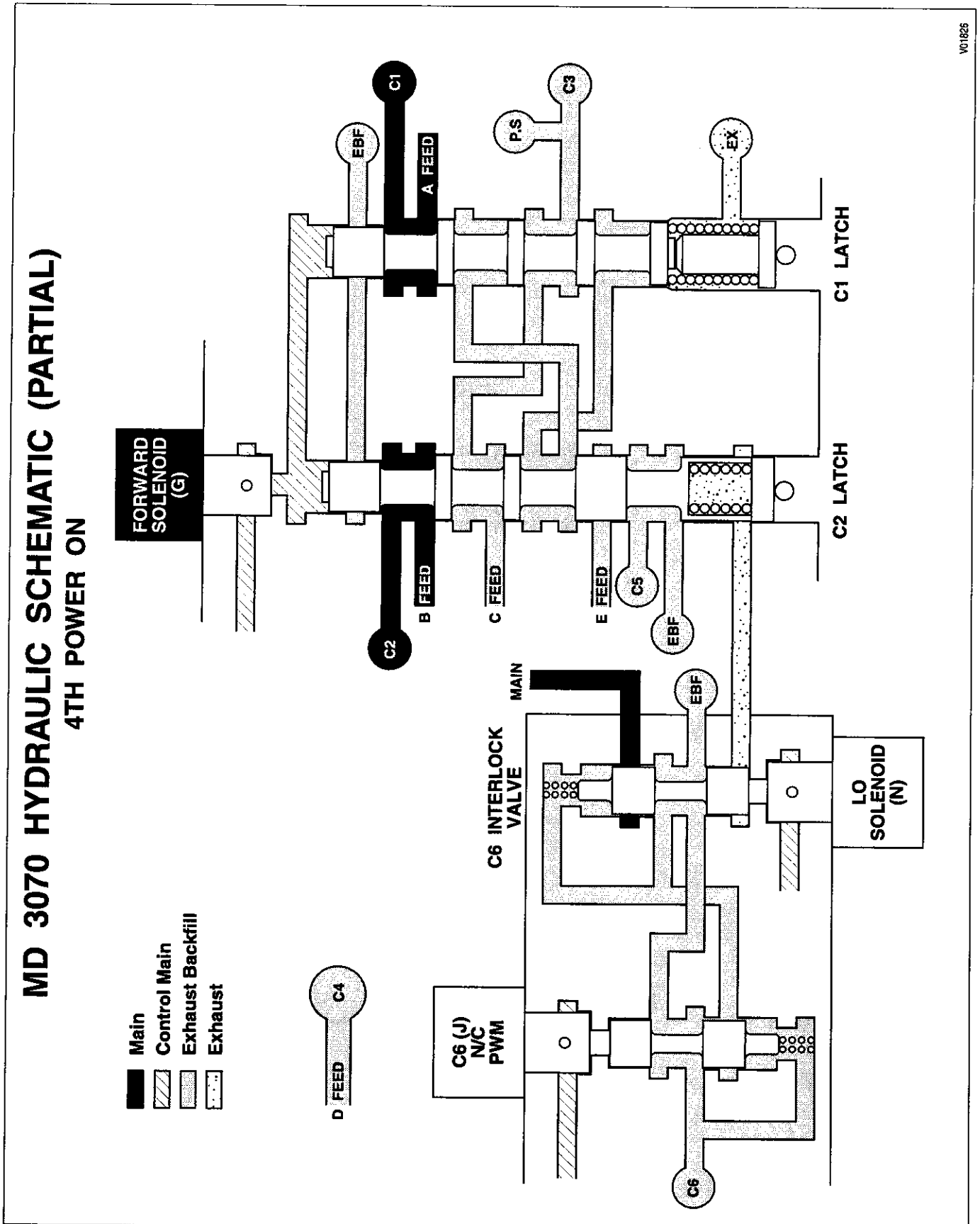
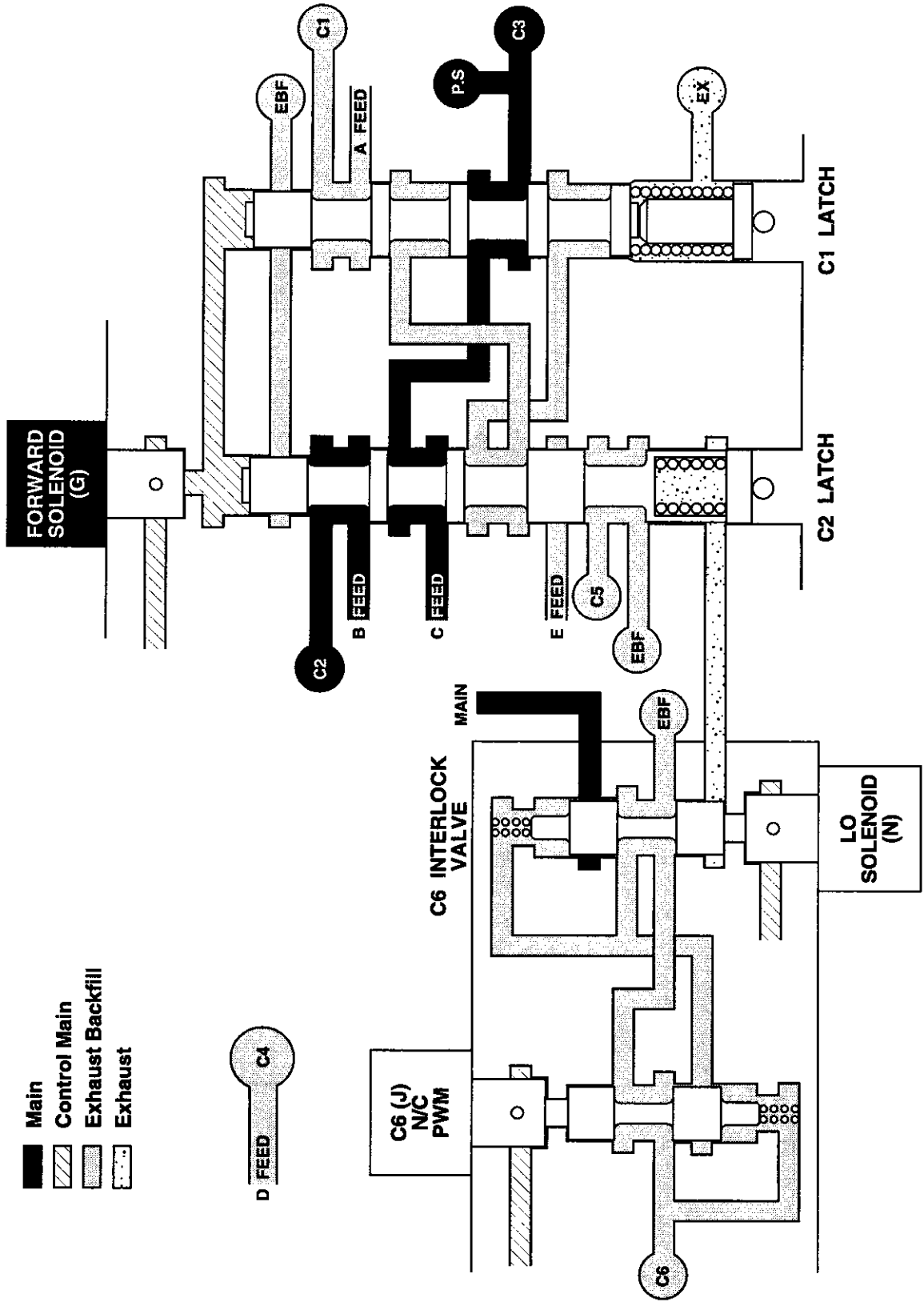

Figure H-16. MD 3070 Hydraulic Schematic — 4th Power On

APPENDIX H — HYDRAULIC SCHEMATICS

MD 3070 HYDRAULIC SCHEMATIC (PARTIAL)
5TH POWER ON



V01827

Figure H-17. MD 3070 Hydraulic Schematic — 5th Power On

APPENDIX H — HYDRAULIC SCHEMATICS

MD 3070 HYDRAULIC SCHEMATIC (PARTIAL)
6TH POWER ON

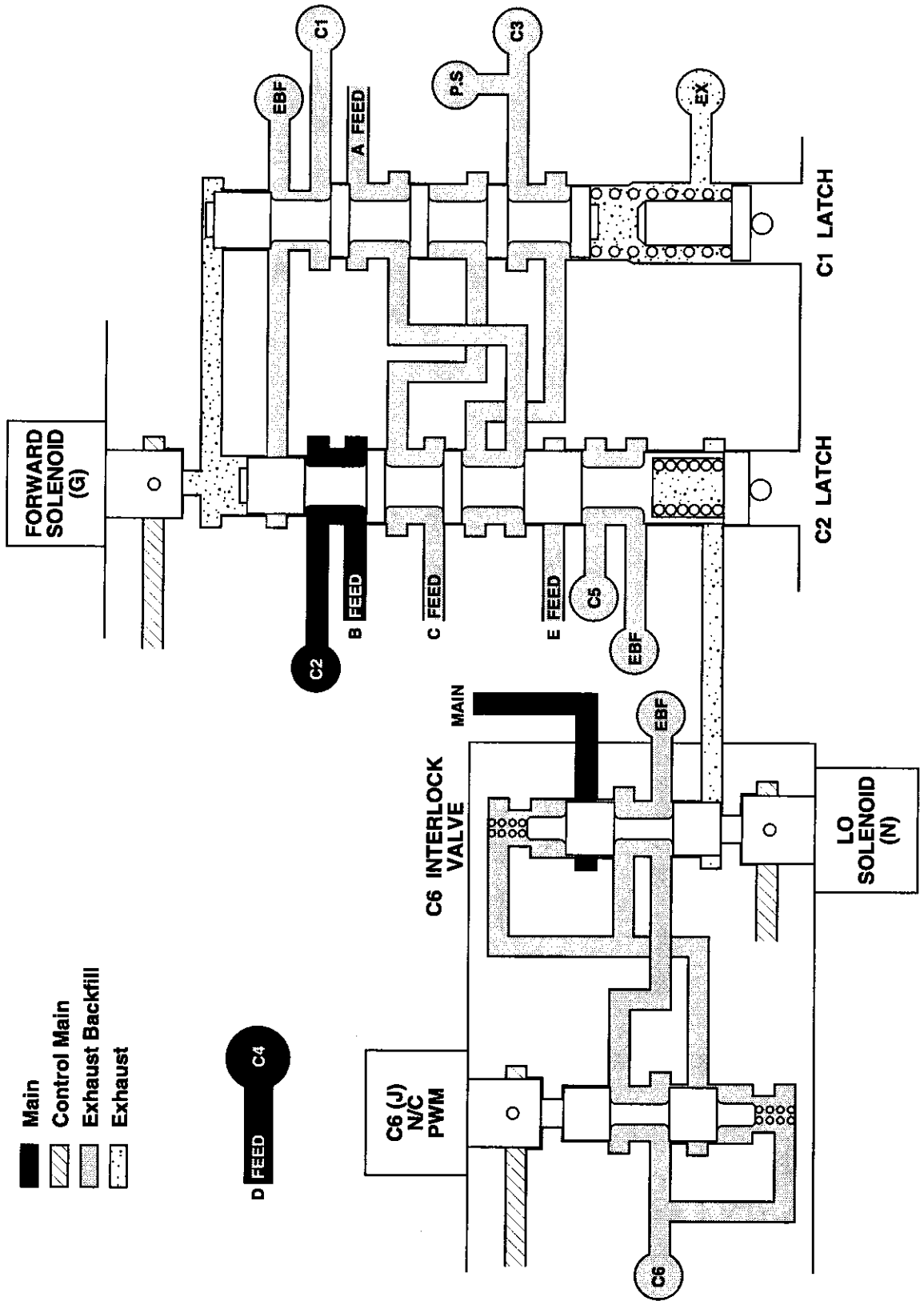

V01826

Figure H-18. MD 3070 Hydraulic Schematic — 6th Power On

APPENDIX H — HYDRAULIC SCHEMATICS

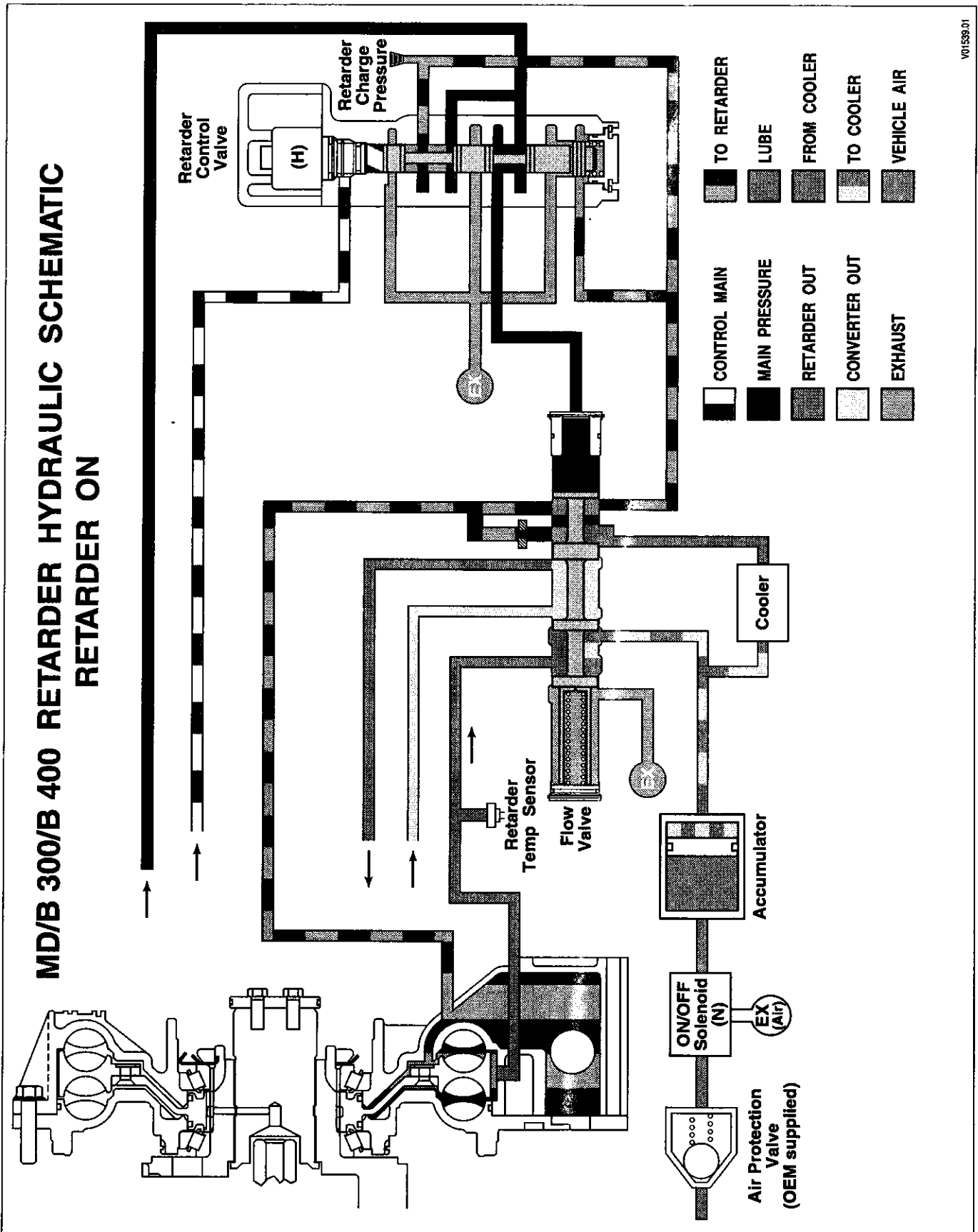

Figure H-19. MD/B 300/B 400 Hydraulic Schematic — Retarder On

APPENDIX H — HYDRAULIC SCHEMATICS

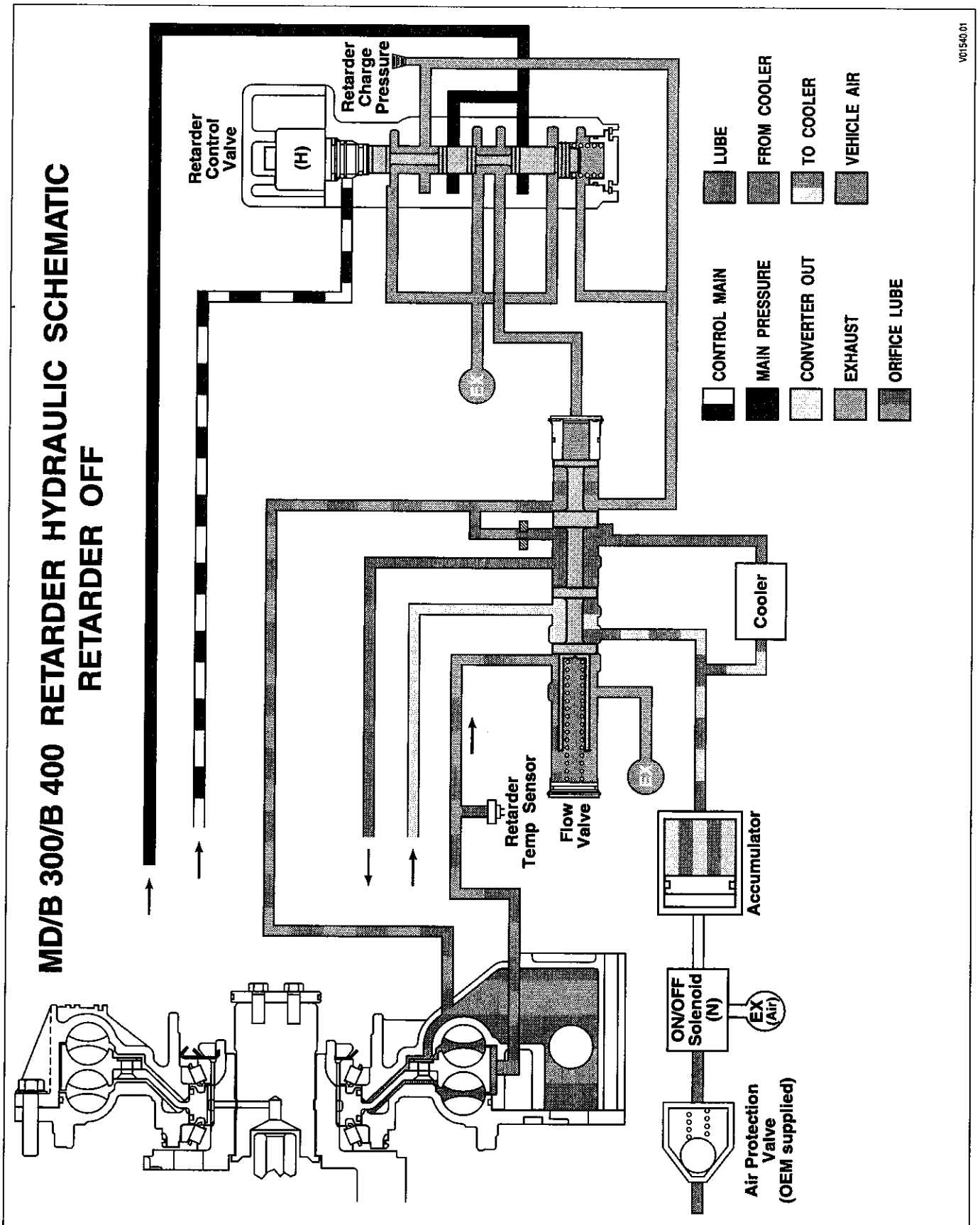
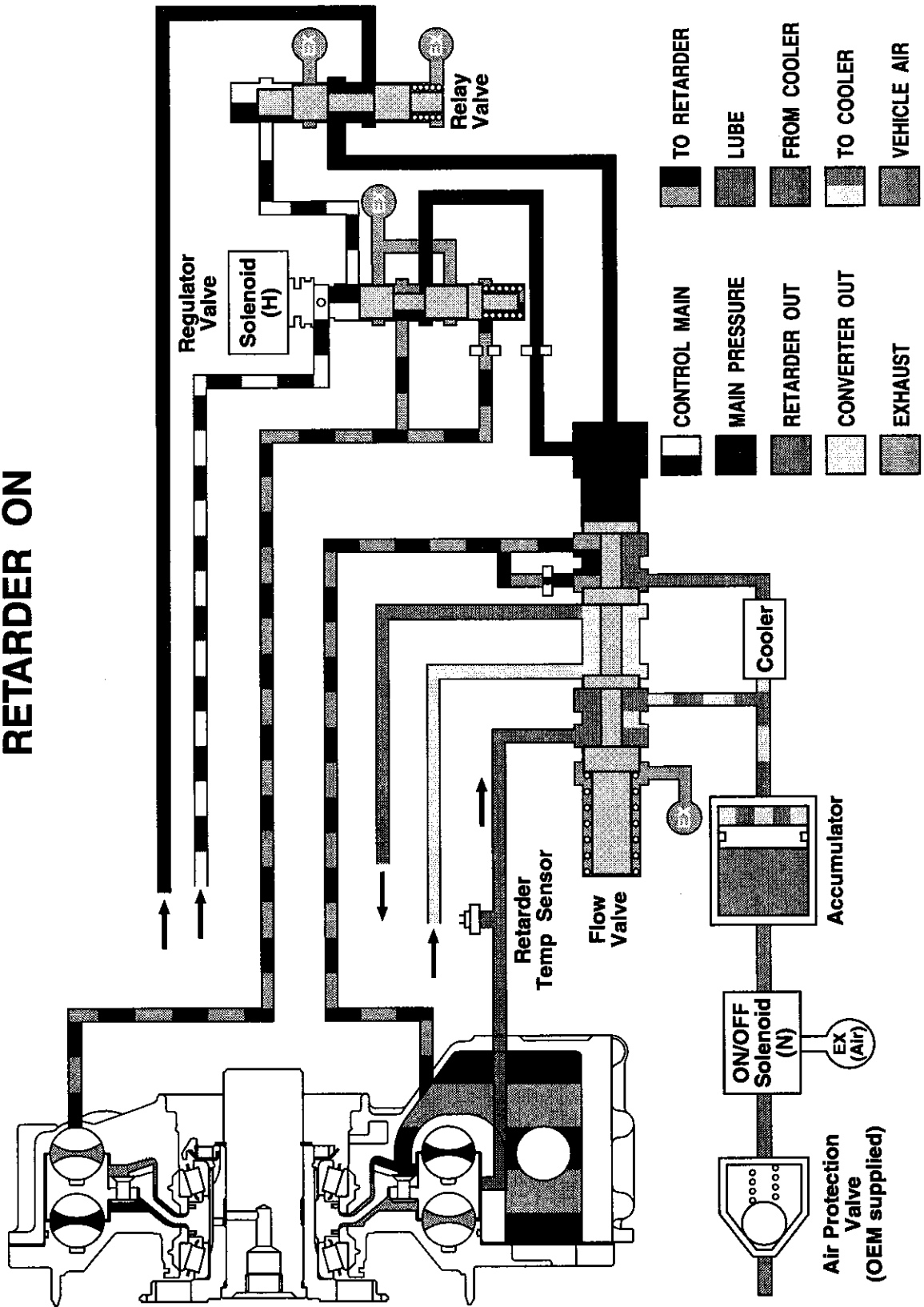

Figure H-20. MD/B 300/B 400 Hydraulic Schematic — Retarder Off

APPENDIX H — HYDRAULIC SCHEMATICS

MD RETARDER HYDRAULIC SCHEMATIC
RETARDER ON



V04626

Figure H-21. MD/B 300/B 400 Hydraulic Schematic — Retarder On (Beginning January 1, 1998)

APPENDIX H — HYDRAULIC SCHEMATICS

MD RETARDER HYDRAULIC SCHEMATIC
RETARDER OFF

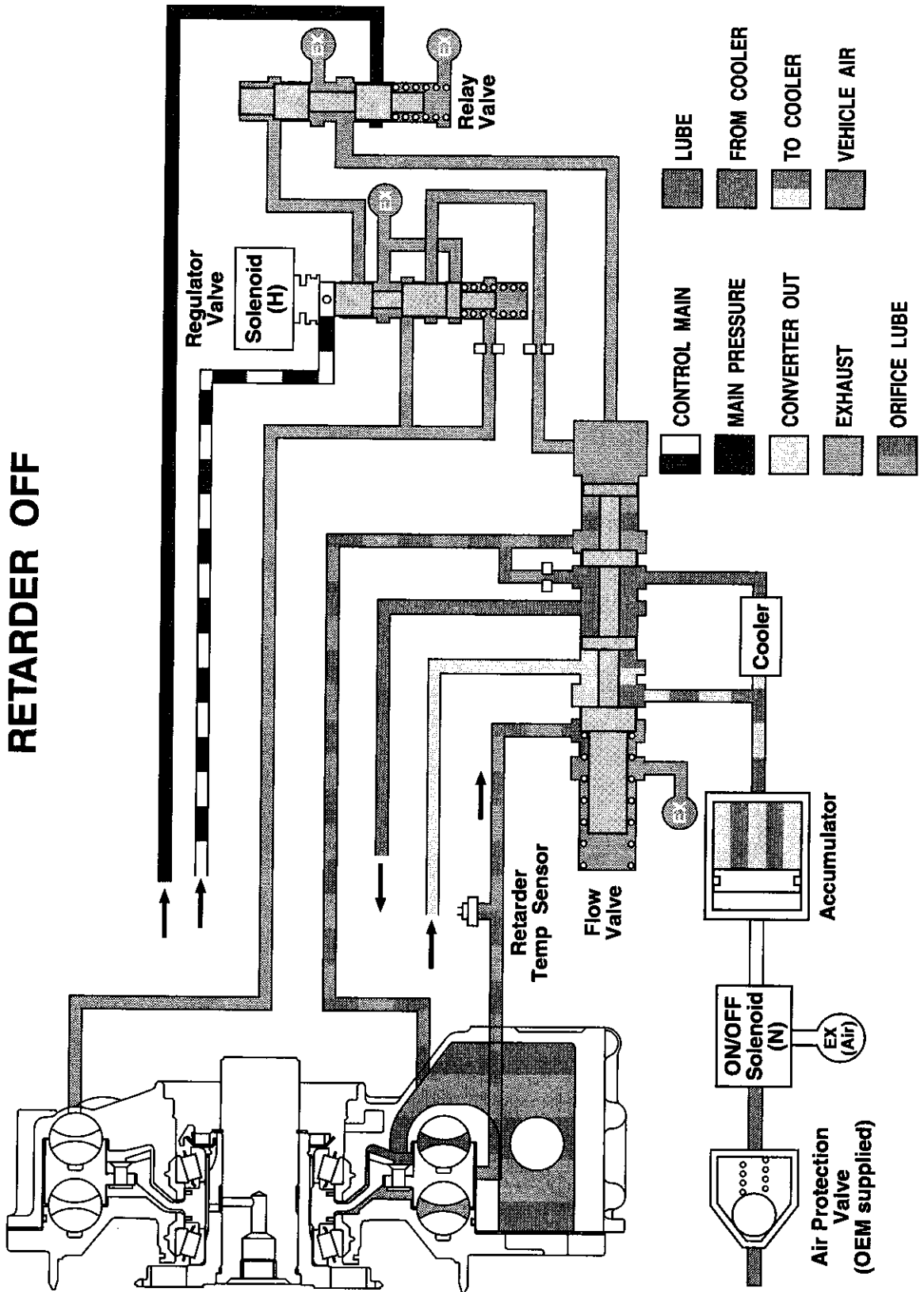

V04627

Figure H-22. HD/B 500 Hydraulic Schematic — Retarder Off (Beginning January 1, 1998)

APPENDIX H — HYDRAULIC SCHEMATICS

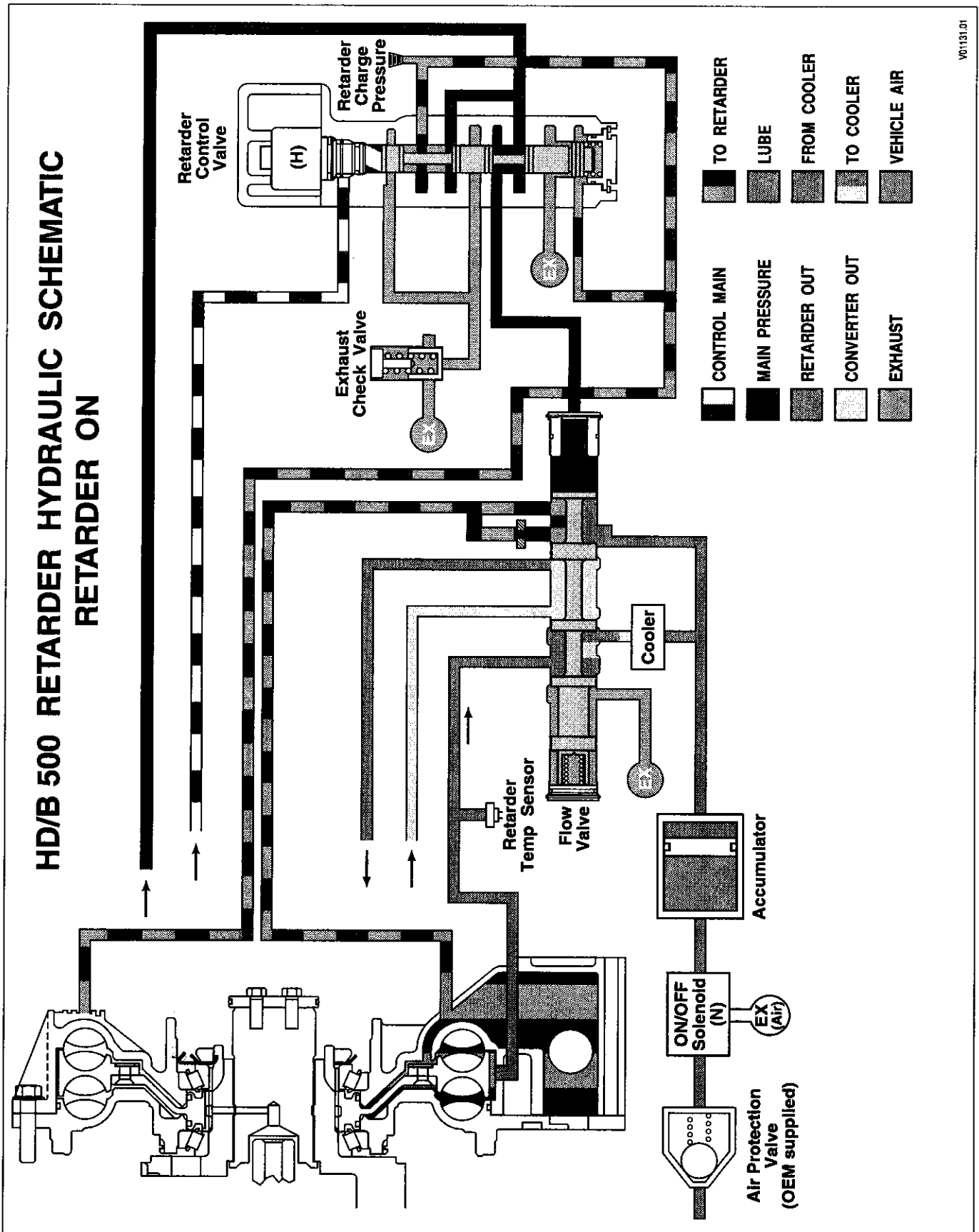

Figure H-23. HD/B 500 Hydraulic Schematic — Retarder On

APPENDIX H — HYDRAULIC SCHEMATICS

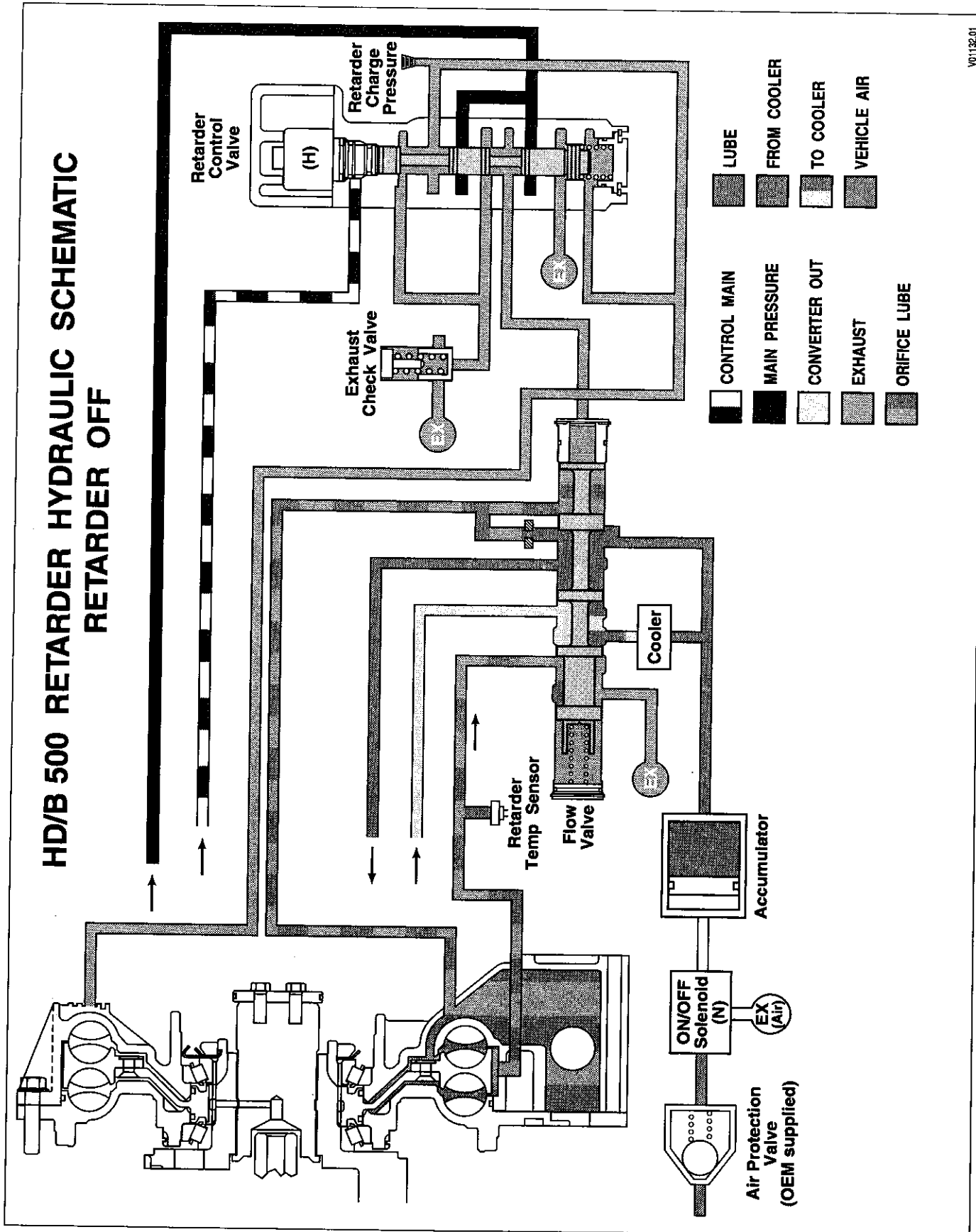

Figure H-24. HD/B 500 Hydraulic Schematic — Retarder Off

APPENDIX H — HYDRAULIC SCHEMATICS

NOTES

APPENDIX J—3000 AND 4000 PRODUCT FAMILIES WIRING SCHEMATIC

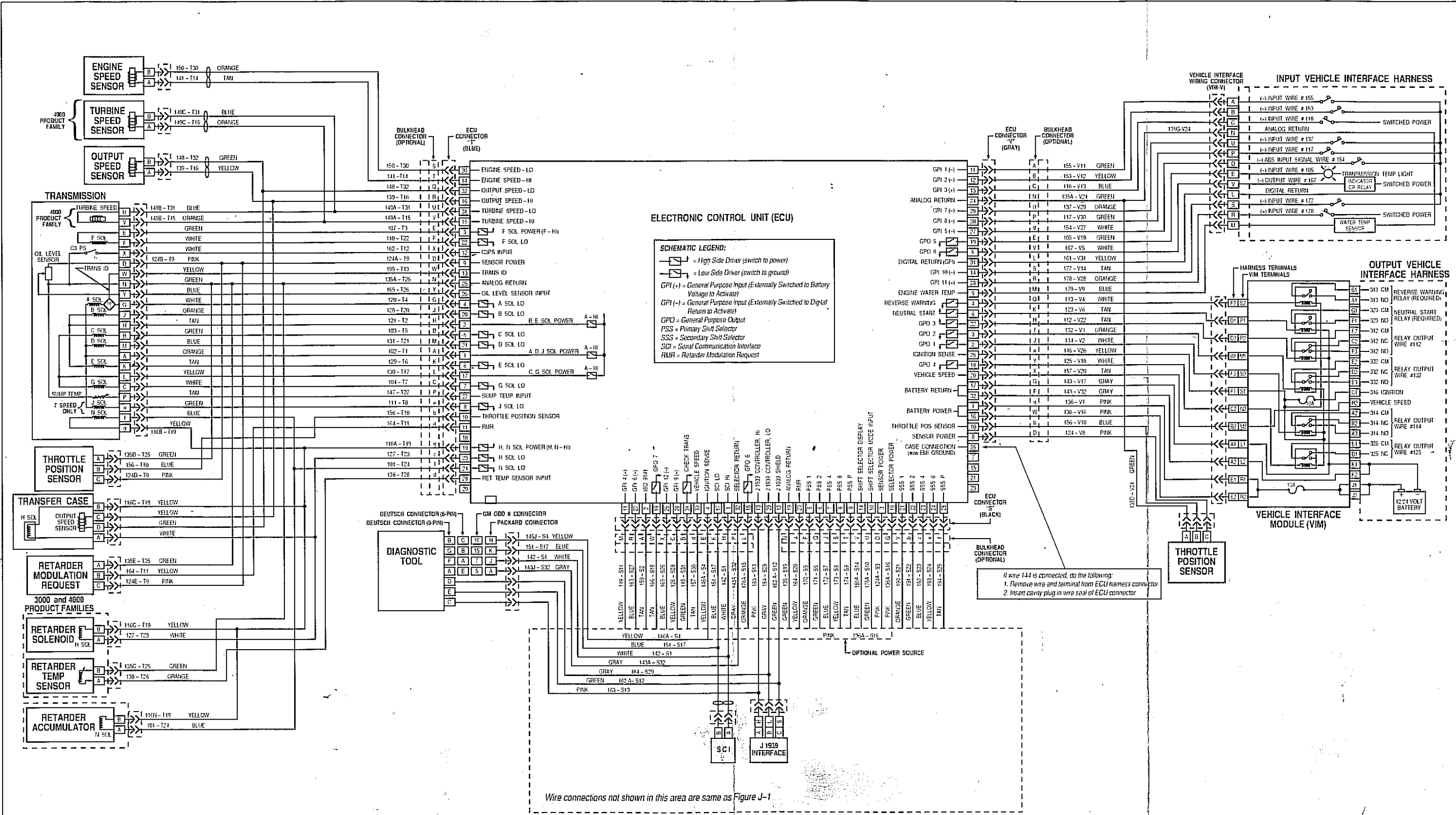
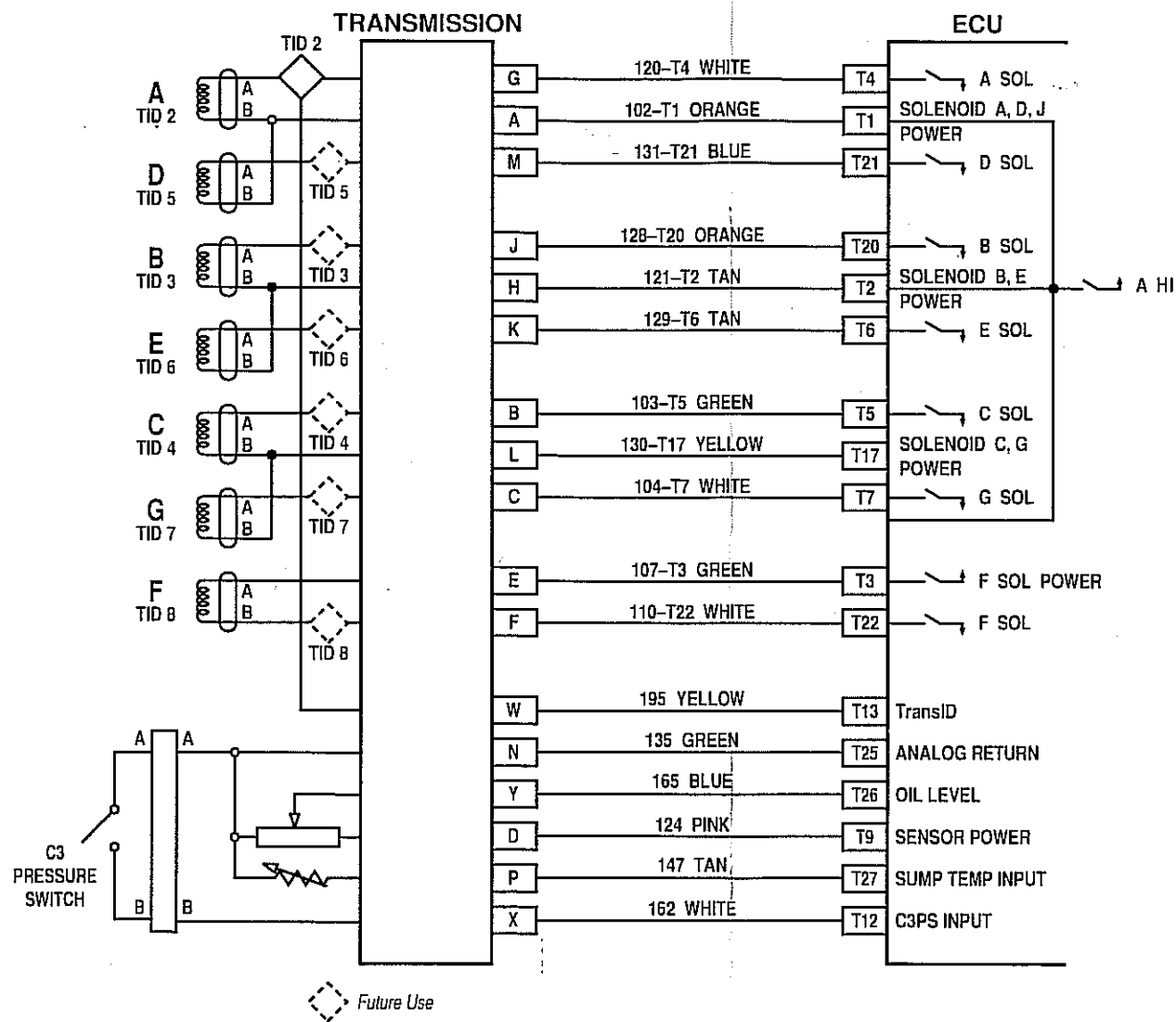

Figure J-2. 3000 and 4000 Product Families Wiring Schematic (TransID 2)

CT FAMILIES WIRING SCHEMATIC



V04855

TID-2 Started Production 1/5/1998
TID-3 Started Production 4/3/2000

APPENDIX K — TRANSID 1 TEMPERATURE SENSOR AND SOLENOID RESISTANCE CHARTS

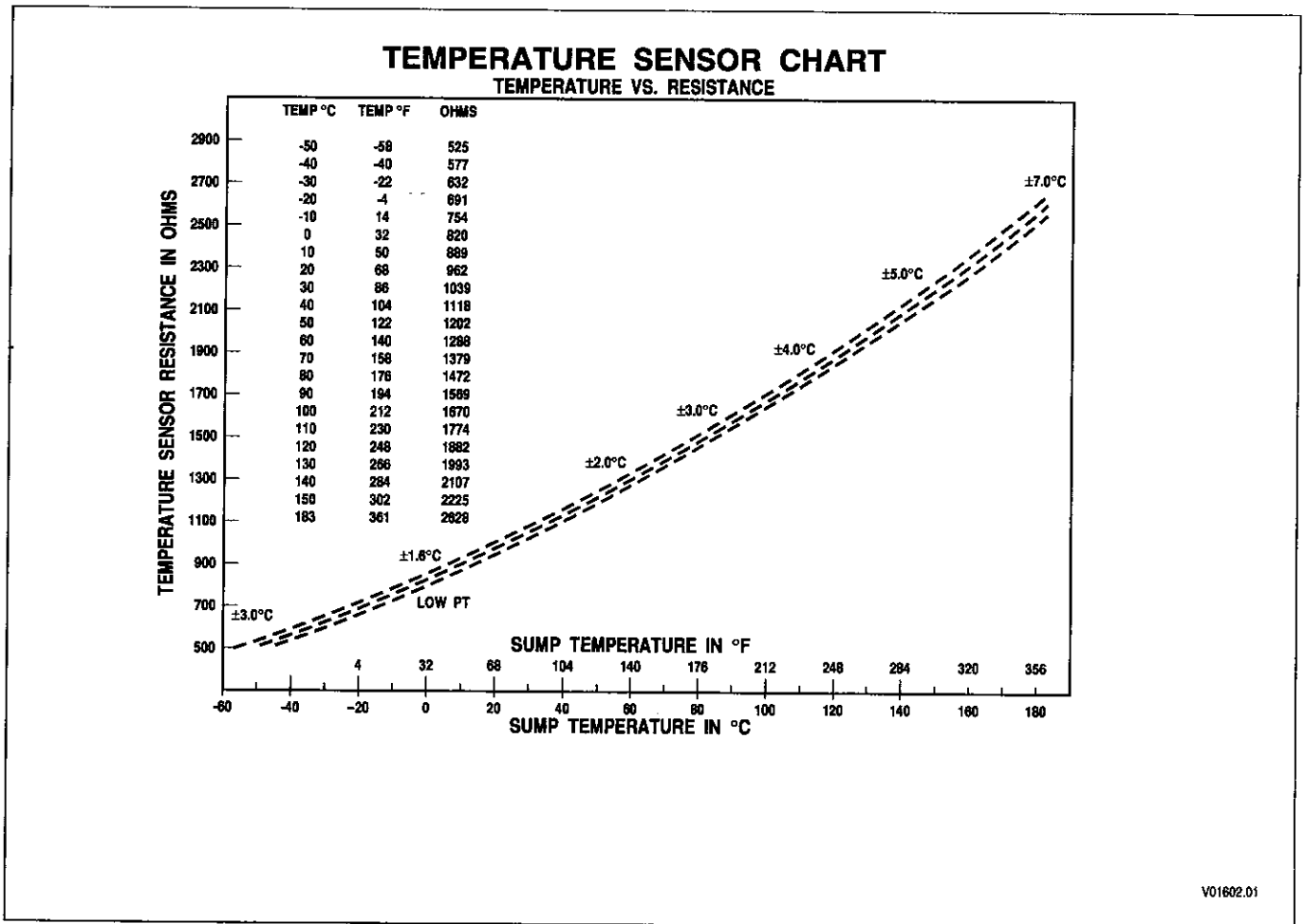

Figure K-1. TransID 1 Temperature Sensor Chart

APPENDIX K — TRANSID 1 TEMPERATURE SENSOR AND SOLENOID RESISTANCE CHARTS

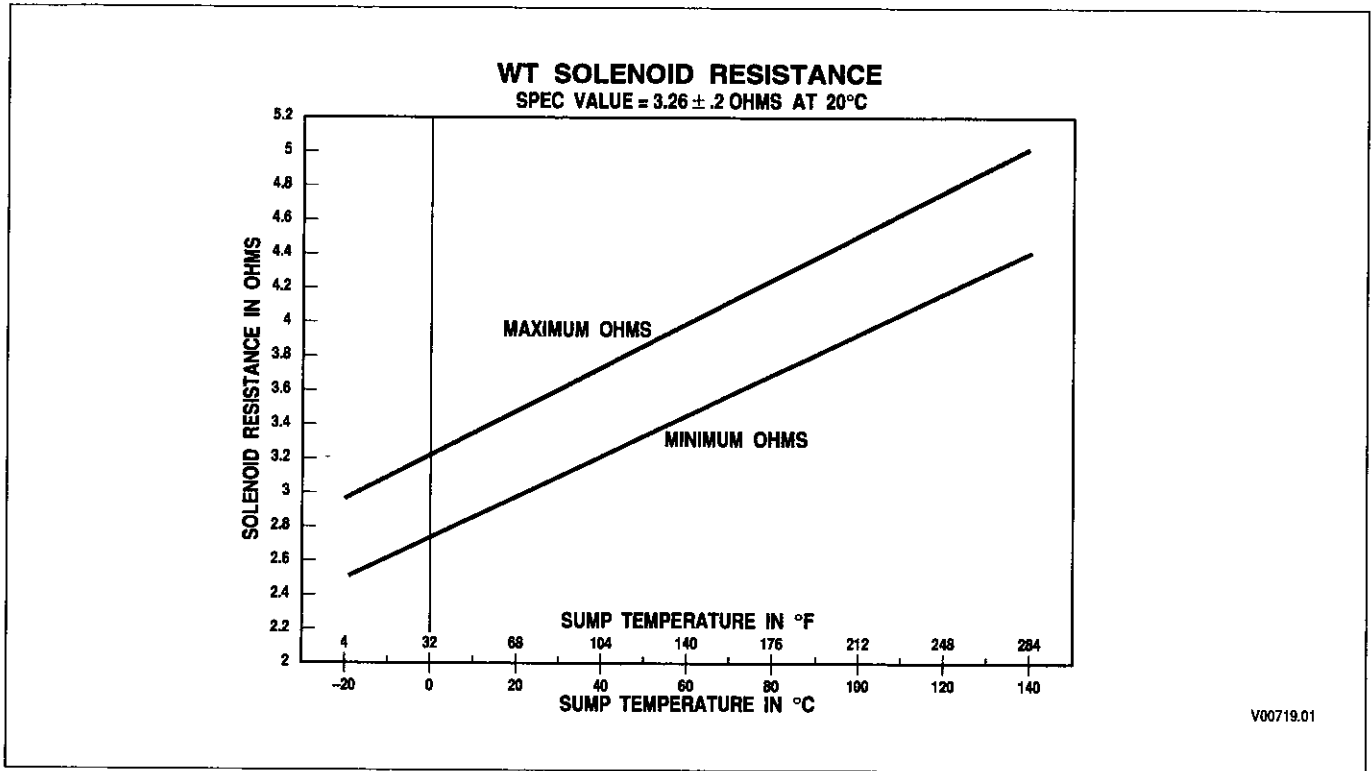

Figure K-2. Solenoid Resistance vs. Temperature Chart

APPENDIX L — EXTERNALLY-GENERATED ELECTRONIC INTERFERENCE**1-1. ELECTROMAGNETIC/RADIO FREQUENCY INTERFERENCE**

Be sure that the ECU for the Allison Transmission Electronic Controls is properly grounded to prevent EMI interference problems. The chassis frame must be connected to the negative post of the vehicle battery. A proper connection to the chassis frame is required. The connection must be free from rust and paint. The electrical integrity of this connection must not deteriorate with the age of the vehicle. If the ECU is cab-mounted, there must be two 1½ to 2 inch braided grounding straps connecting the cab structure to the chassis frame. DO NOT connect wire 144-V25 to a bus bar or to any single terminal carrying other electrical loads.

All electrical and electronic systems generate electromagnetic fields that can interfere with other electronic systems. Allison Transmission electronic transmission controls comply with Federal Communications Commission (FCC) regulations and other guidelines concerning emitted radio frequency interference for transportation electronics. The position of Allison Transmission Division of General Motors is that manufacturers and installers of EMI/RFI emitting equipment are responsible for adhering to FCC regulations and other guidelines concerning emitted radio frequency interference for transportation electronics.

Some radio-telephone or two-way communication radios (land-mobile radio), or the manner in which they are installed, can adversely affect vehicle operation or be affected by other vehicle components. Expenses incurred to protect vehicle-related systems from EMI/RFI emissions by radio-telephone or two-way communications radios (land-mobile radio) or to integrate such devices into vehicles are not the responsibility of Allison Transmission.

1-2. GENERAL GUIDELINES FOR RADIO EQUIPMENT INSTALLATION

The following general guidelines for installing radio-telephone or two-way communications radios (land-mobile radio) in a vehicle supplement, but DO NOT replace, detailed instructions provided by the radio equipment manufacturer. Detailed installation instructions are the sole responsibility of the radio equipment manufacturer.

Experience has shown that most EMI/RFI problems can be prevented or eliminated by following the guidelines. If EMI/RFI problems persist after following the guidelines and after ensuring the installation conforms to the guidelines, contact the vehicle and radio equipment manufacturers for additional installation or equipment operation instructions.

A. Transmitter Installation

1. Locate remote radio transmitters as far away from other electronic devices and as near to the side of the vehicle body as possible.
2. Mount transceivers (transmitter and receiver in one box) under the dash so as not to interfere with vehicle controls or passenger movement.

B. Antenna Installation

Each vehicle and body style react differently to radio frequency energy. When dealing with an unfamiliar vehicle, test various antenna locations by using a magnetic mount antenna and checking for adverse effects. Antenna location is a major factor in EMI/RFI problems.

C. Antenna Cable Routing

1. Use high quality, 95 percent shield coverage, coaxial (coax) cable. Route the coax well away from any electronic components.
2. Route antenna cables as far away from vehicle wiring as possible to reduce the likelihood of the vehicle wiring acting as an antenna for interference.

APPENDIX L — EXTERNALLY-GENERATED ELECTRONIC INTERFERENCE**D. Radio Wiring and Connector Location**

1. Connect transmitter power leads directly to the battery.
2. For transceivers (transmitter and receiver in one box) with ignition control, place a 12V power contactor at the vehicle battery. Drive the contactor coil, through an appropriate in-line fuse, from an ignition circuit not powered during engine cranking.
3. Any negative lead from a handset or control unit must return to battery negative.
4. Connect the positive lead from a handset or control unit directly to battery.
5. Fuse handset or control unit positive and negative leads separately from the transceiver negative and positive leads. Use correctly rated fuses.

E. Power and Ground Wire Routing

Route radio power and ground wires as far away as possible from electronic control modules.

F. Troubleshooting

The following are common causes of EMI/RFI problems:

- Power leads connected to points other than the battery
- Improper antenna location
- Poor shielding or connections to antenna cable
- Transmitter or transceiver wiring too close to vehicle electronics

1-3. EXTERNALLY-GENERATED SPEED SENSOR SIGNALS**A. Checking for Externally-Generated Speed Sensor Signals**

Use the following procedures to determine if speed sensor signals generated by a source external to the transmission or wiring harness are present:

1. Turn ignition ON.
2. Keep engine OFF.
3. If the ECU is ON (shift selector display remains illuminated), connect the Pro-Link[®] Diagnostic tool.

NOTE: *If false speed signals were present at the previous shutdown, the ECU might still be "on" even though the ignition is "off." The Pro-Link[®] is powered by ignition power so the ignition must be "on" to use the Pro-Link[®] to read the speed signals.*

4. Read speed sensor signals.
5. If a speed sensor signal is other than one (1), then there is a short to another circuit that is carrying an AC or PWM signal.
6. Check the resistance of the sensor.
7. Check for shorts to other circuits within the harness or transmission connector.
8. Check to ensure there is no conductive material inside the connector.
9. Check to be sure speed sensor circuit wires are a twisted pair.
10. Check to ensure a properly grounded drain wire.
11. Check for the presence of a strong external AC signal.
12. Repair or replace parts as required.

APPENDIX M — DIAGNOSTIC TREE — WT HYDRAULIC SYSTEM

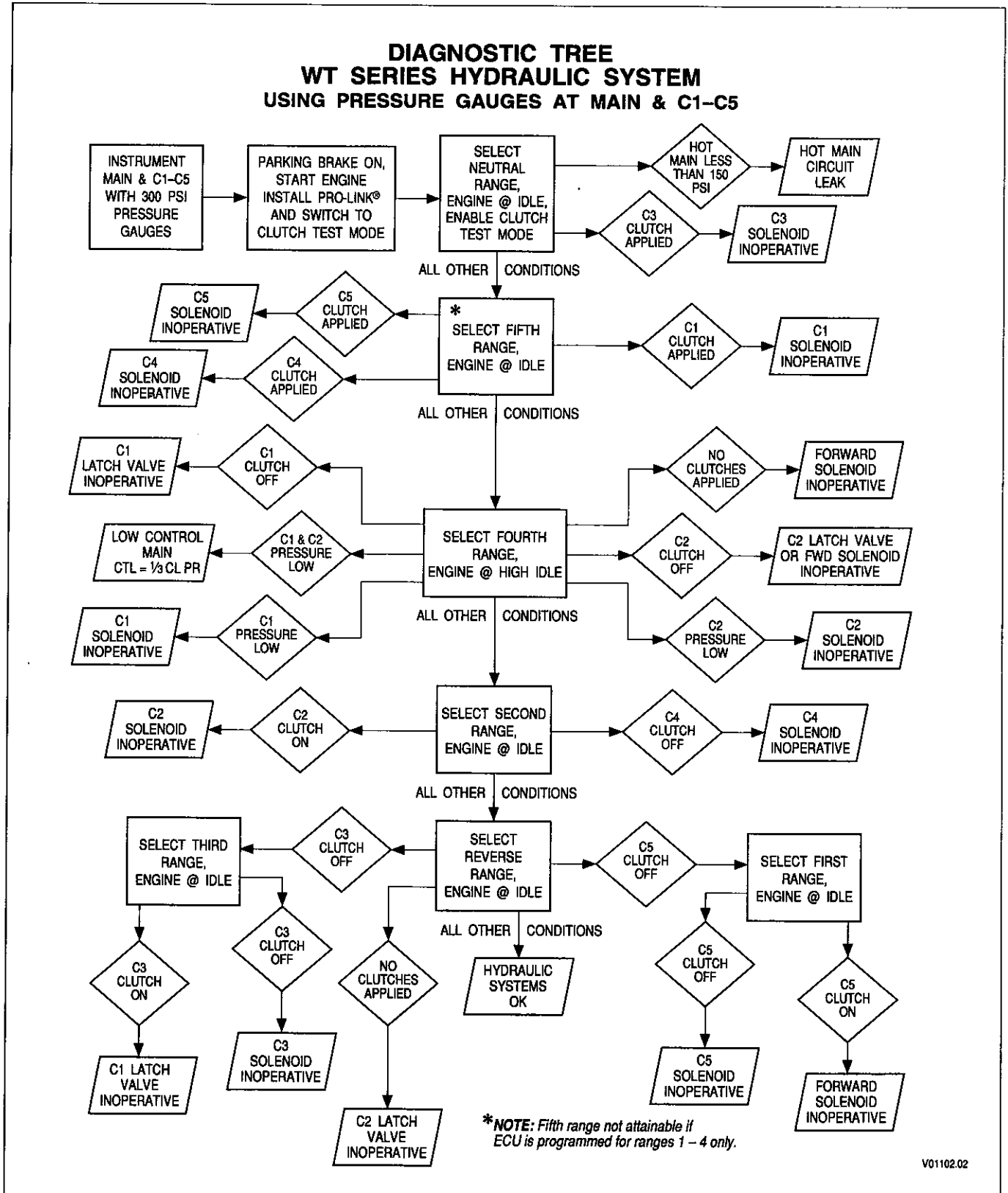

V01102.02

Figure M-1. Diagnostic Tree — WT Series Hydraulic System With Gauges

APPENDIX M — DIAGNOSTIC TREE — WT HYDRAULIC SYSTEM

**DIAGNOSTIC TREE
WT SERIES HYDRAULIC SYSTEM
NOT USING PRESSURE GAUGES**

**NOTE: Fifth range not attainable if ECU is programmed for ranges 1 – 4 only.*

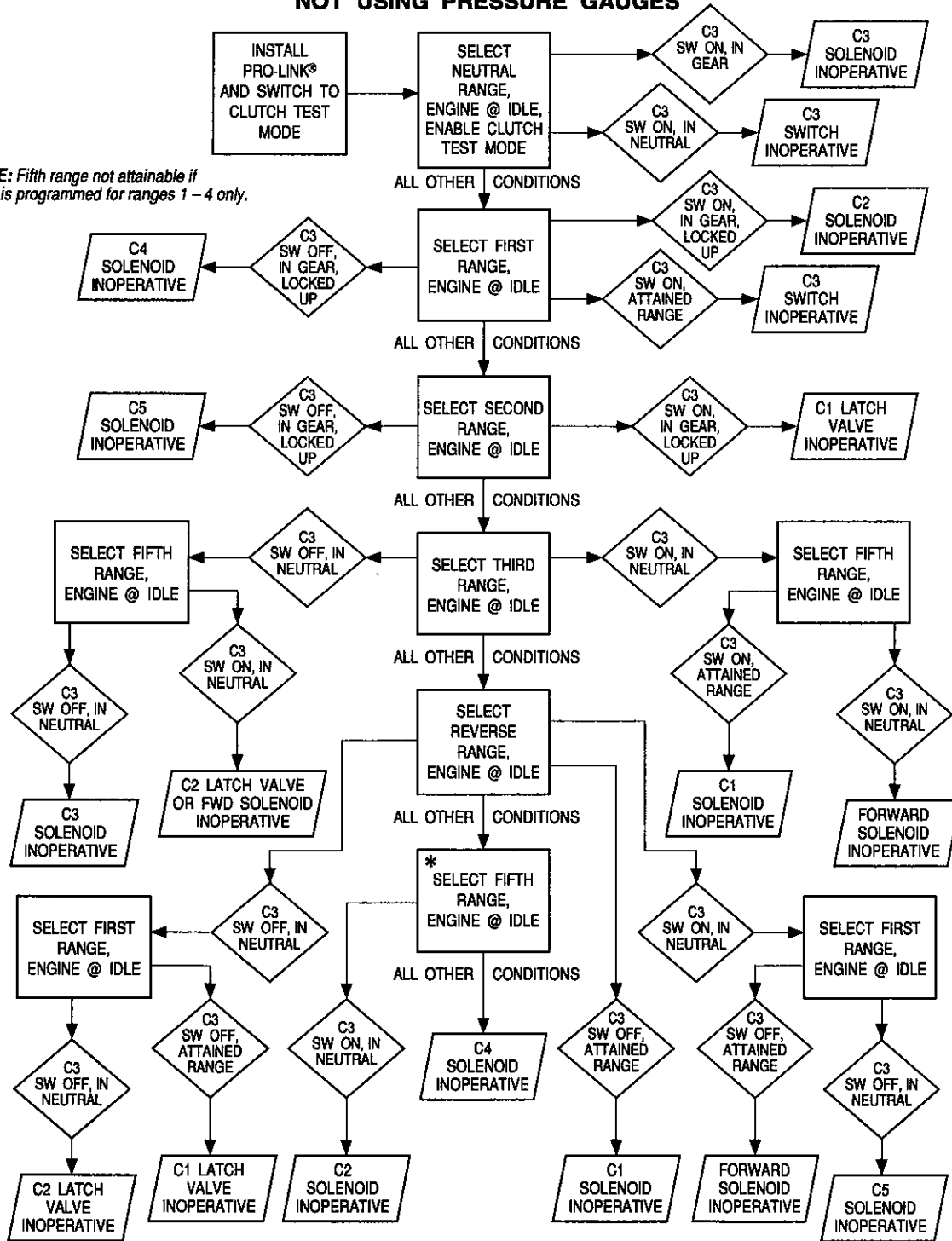

V01103.02

Figure M-2. Diagnostic Tree — WT Series Hydraulic System Without Gauges

APPENDIX N — PRO-LINK® 9000 DIAGNOSTIC DATA READER INFORMATION

Pro-link® 9000 Diagnostic Tools

The WTEC III system will require new Pro-Link® 9000 hardware for reprogramming and diagnostics. The following is a list of required updates to the current Pro-Link® 9000 hardware:

Hardware	Tool P/N
Diagnostic Cartridge	J38500-303
PROM Update Kit	J38500-313
MultiProtocol Cartridge (MPC)	J38500-1500A
Reprogramming PCMCIA Card*	J38500-1700
Diagnostic Card*	J38500-1800

* Requires J38500-1500A to function

Limited diagnostic information for the WTEC III system can be accessed through the current WTEC II Pro-Link® 9000 hardware. This diagnostic information will however be limited to that information that is common to the WTEC II and WTEC III systems. Access to information described in this SIL can only be accessed through **either** the WTEC III Diagnostic Cartridge or by updating the current WTEC II Diagnostic Cartridge with the PROM update kit or the WTEC III Reprogramming Cartridge.

The MultiProtocol Cartridge (MPC) and the Reprogramming Card are required to modify customer constants and alter Calibration packages within the WTEC III ECU. After completing an ATD-approved training class, those ordering a reprogramming cartridge are required to submit a copy of their completion certificate with their order. This serves as proof of eligibility to purchase these items. Training is available from ATD and ATD distributors.

APPENDIX N — PRO-LINK® 9000 DIAGNOSTIC DATA READER INFORMATION

NOTES

APPENDIX P — INPUT/OUTPUT FUNCTIONS

The schematics which follow were taken from the Sales Tech Data Book entitled "WTEC III Controls." These schematics provide detail information needed to correctly perform input and output function connections. For an overview of Input/Output Functions, refer to Section 7 of this manual.

WARNING!

These schematics show the intended use of the specified controls features which have been validated in the configuration shown. Any miswiring or use of these features which differs from that shown could result in damage to equipment or property, personal injury, or loss of life. ALLISON TRANSMISSION IS NOT LIABLE FOR THE CONSEQUENCES ASSOCIATED WITH MISWIRING OR UNINTENDED USE OF THESE FEATURES.

SECONDARY SHIFT SCHEDULE

USES: Provides operator selection of dual shift schedules. Can be used for performance/economy, loaded/empty, or other shift schedule combinations.

VARIABLES TO SPECIFY: None

VOCATIONS: Various

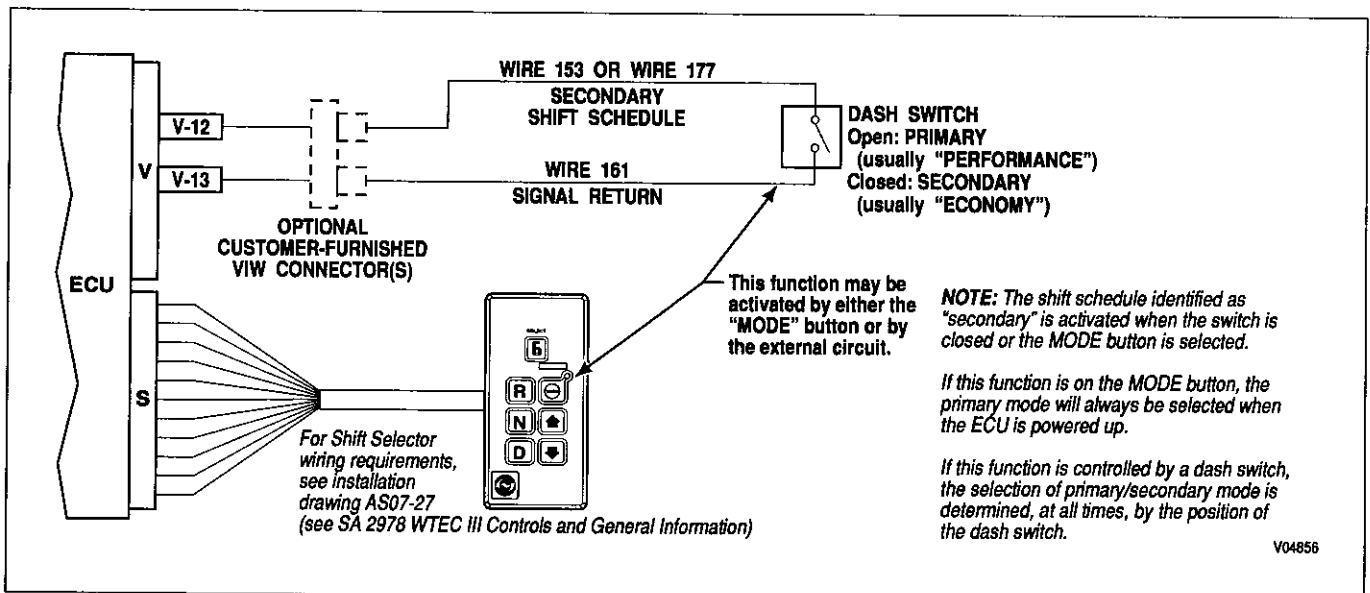

Figure P-1. Secondary Shift Schedule

APPENDIX P — INPUT/OUTPUT FUNCTIONS

WARNING!

These schematics show the intended use of the specified controls features which have been validated in the configuration shown. Any miswiring or use of these features which differs from that shown could result in damage to equipment or property, personal injury, or loss of life. ALLISON TRANSMISSION IS NOT LIABLE FOR THE CONSEQUENCES ASSOCIATED WITH MISWIRING OR UNINTENDED USE OF THESE FEATURES.

D1 SELECTION

USES: Provides a convenient means of attaining 1st range hold for pushbutton shift selectors. Range to select is programmable for Primary and Secondary modes.

VARIABLES TO SPECIFY: Primary Mode selected range, Secondary Mode selected range (usually 1st range).
Can be used only on the MODE button.

VOCATIONS: Various

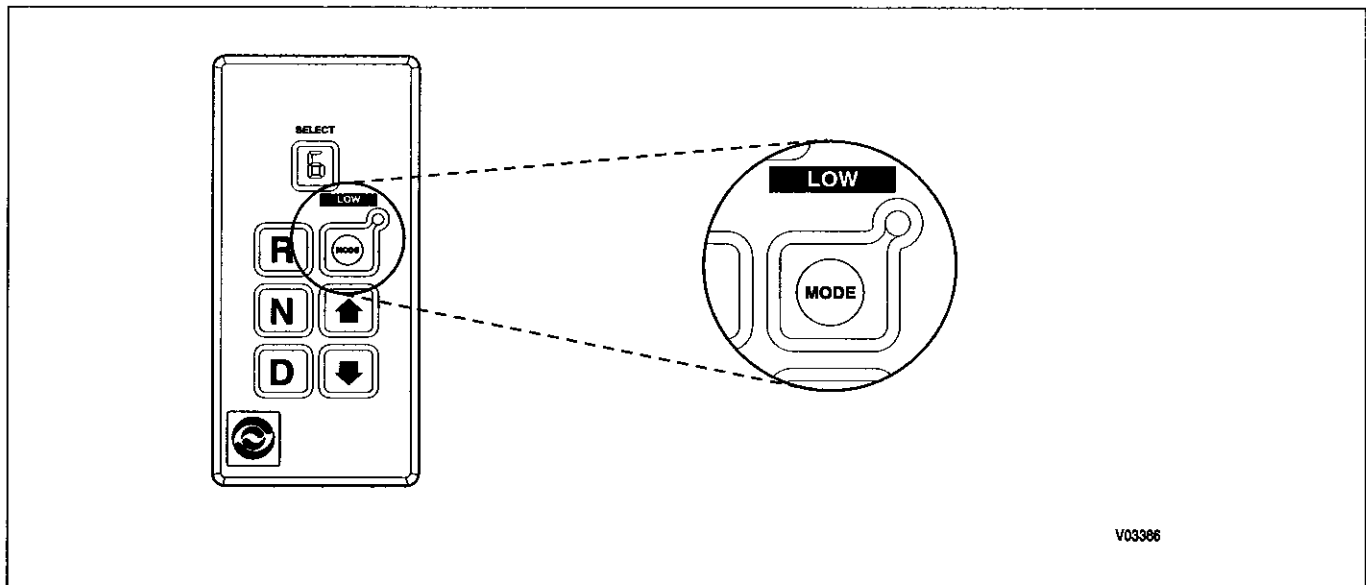

Figure P-2. D1 Selection

APPENDIX P — INPUT/OUTPUT FUNCTIONS

WARNING!

These schematics show the intended use of the specified controls features which have been validated in the configuration shown. Any miswiring or use of these features which differs from that shown could cause unscheduled operation of the PTO or other unpredictable operation resulting in damage to equipment or property, personal injury, or loss of life. ALLISON TRANSMISSION IS NOT LIABLE FOR THE CONSEQUENCES ASSOCIATED WITH MISWIRING OR UNINTENDED USE OF THESE FEATURES.

PTO ENABLE (USING “PTO” SWITCH)

USES: Permits PTO to be engaged only when engine speed and output speed are in allowable range and throttle is low. Also disengages PTO if speeds are exceeded.

VARIABLES TO SPECIFY: Minimum and maximum engine speed for engagement, maximum engine speed for allowable operation, minimum and maximum output speed for engagement, maximum output speed for allowable operation.

VOCATIONS: Various (with usage of PTO)

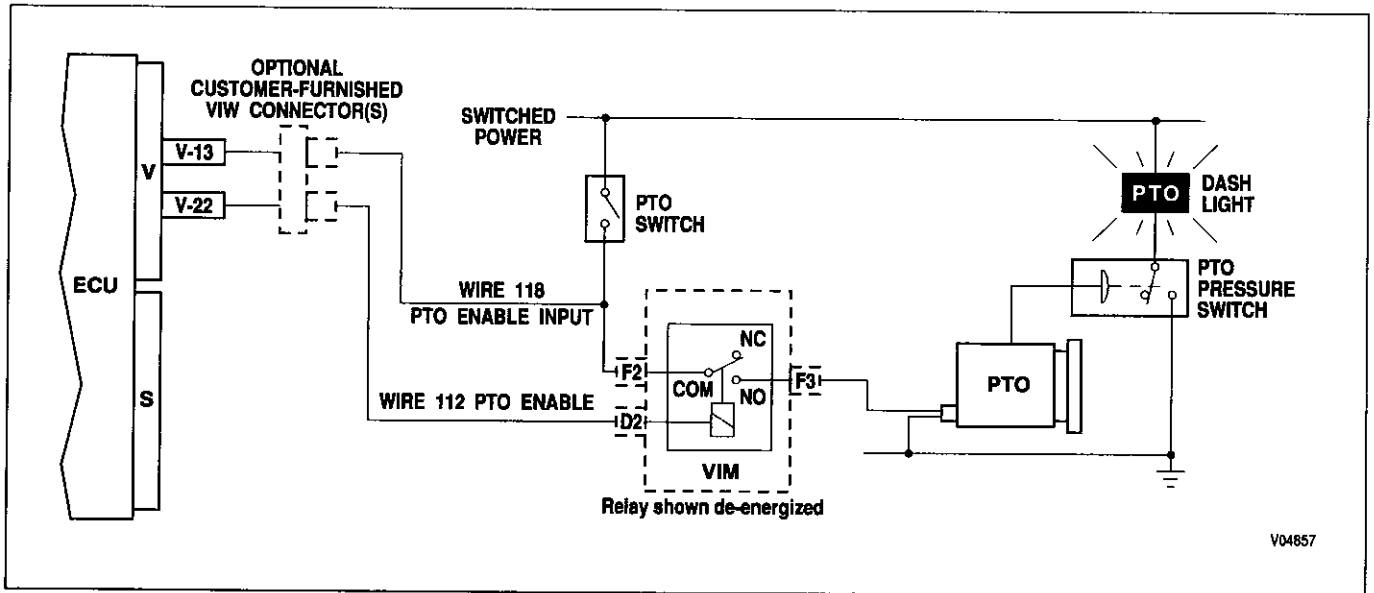

Figure P-3. PTO Enable (Using “PTO” Switch)

APPENDIX P — INPUT/OUTPUT FUNCTIONS

WARNING!

These schematics show the intended use of the specified controls features which have been validated in the configuration shown. Any miswiring or use of these features which differs from that shown could result in damage to equipment or property, personal injury, or loss of life. ALLISON TRANSMISSION IS NOT LIABLE FOR THE CONSEQUENCES ASSOCIATED WITH MISWIRING OR UNINTENDED USE OF THESE FEATURES.

PTO ENABLE (USING “PTO” SWITCH — OPTIONAL)

USES: Permits PTO to be engaged only when engine speed and output speed are in allowable range and throttle is low. Also disengages PTO if speeds are exceeded.

VARIABLES TO SPECIFY: Minimum and maximum engine speed for engagement, maximum engine speed for allowable operation, minimum and maximum output speed for engagement, maximum output speed for allowable operation.

VOCATIONS: Various (with usage of PTO)

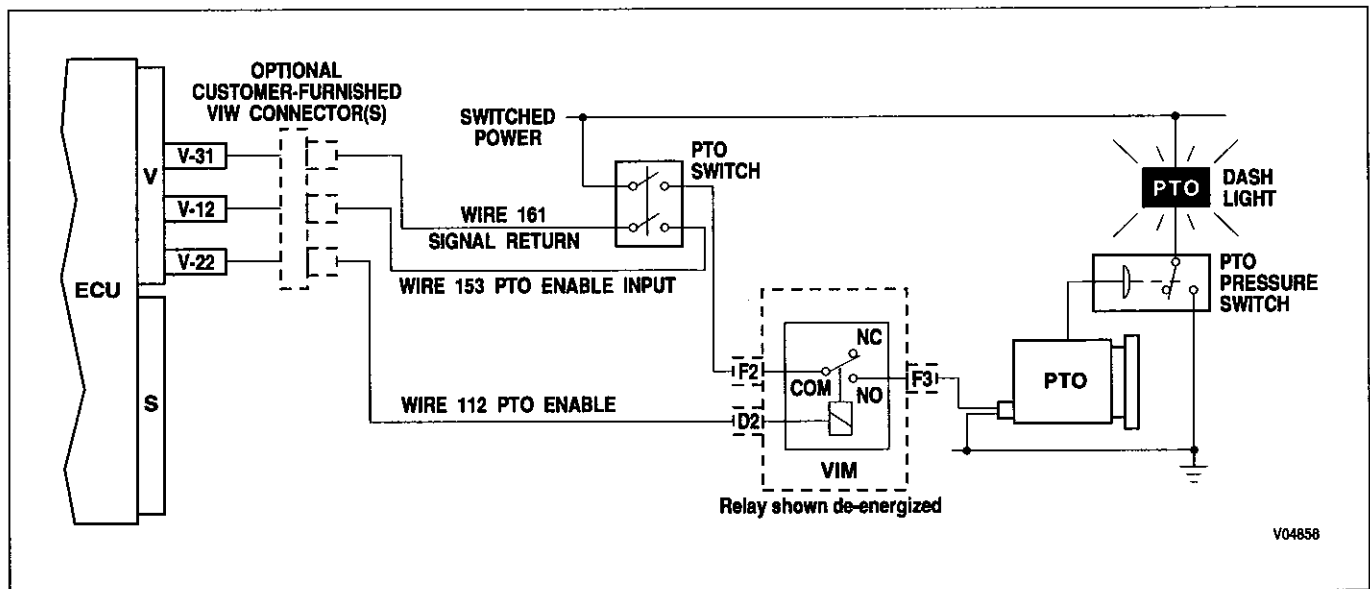

Figure P-4. PTO Enable (Using “PTO” Switch — Optional)

APPENDIX P — INPUT/OUTPUT FUNCTIONS

WARNING!

These schematics show the intended use of the specified controls features which have been validated in the configuration shown. Any miswiring or use of these features which differs from that shown could result in damage to equipment or property, personal injury, or loss of life. ALLISON TRANSMISSION IS NOT LIABLE FOR THE CONSEQUENCES ASSOCIATED WITH MISWIRING OR UNINTENDED USE OF THESE FEATURES.

PTO ENABLE (USING “MODE” BUTTON)

USES: Permits PTO to be engaged only when engine speed and output speed are in allowable range and throttle is low. Also disengages PTO if speeds are exceeded.

VARIABLES TO SPECIFY: Minimum and maximum engine speed for engagement, maximum engine speed for allowable operation, minimum and maximum output speed for engagement, maximum output speed for allowable operation.

VOCATIONS: Various (with usage of PTO)

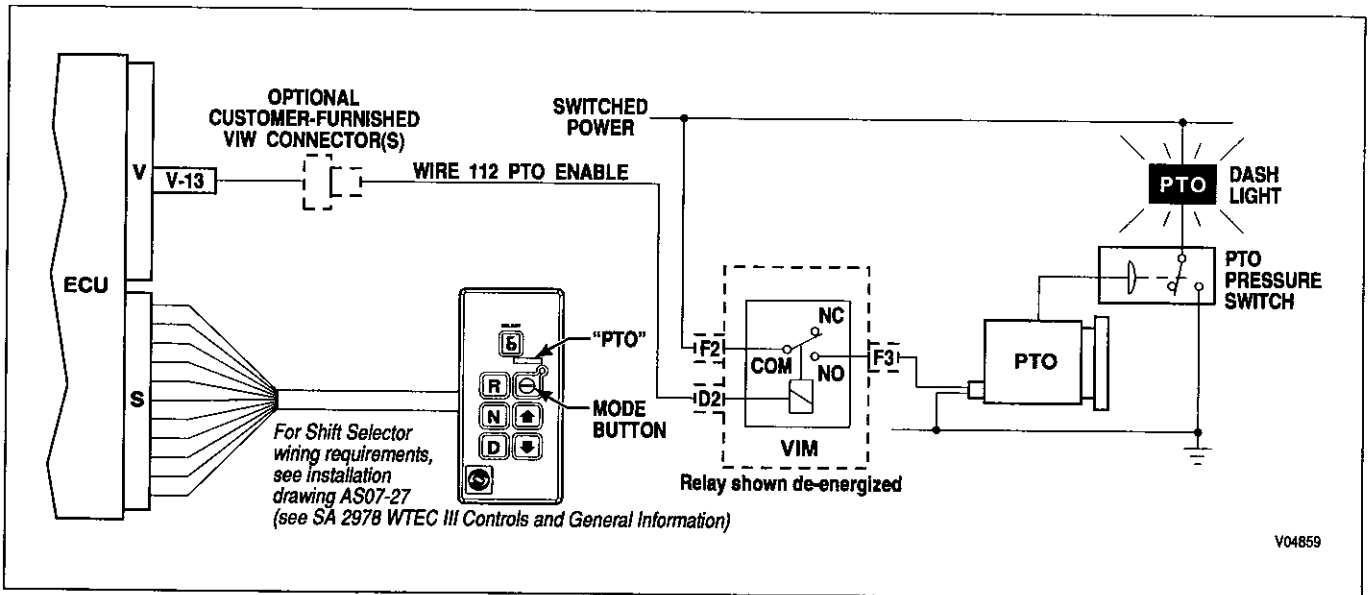

Figure P-5. PTO Enable (Using “MODE” Button)

APPENDIX P — INPUT/OUTPUT FUNCTIONS

WARNING!

These schematics show the intended use of the specified controls features which have been validated in the configuration shown. Any miswiring or use of these features which differs from that shown could result in damage to equipment or property, personal injury, or loss of life. ALLISON TRANSMISSION IS NOT LIABLE FOR THE CONSEQUENCES ASSOCIATED WITH MISWIRING OR UNINTENDED USE OF THESE FEATURES.

SHIFT SELECTOR TRANSITION

USES: When two shift selectors are used, to select which one is active.

VARIABLES TO SPECIFY: None

VOCATIONS: Various

WARNING!

If this function is enabled in the shift calibration, the function **MUST** be integrated into the vehicle wiring. If the function is available in the shift calibration but will not be used in the vehicle, it **MUST** be disabled in the calibration.

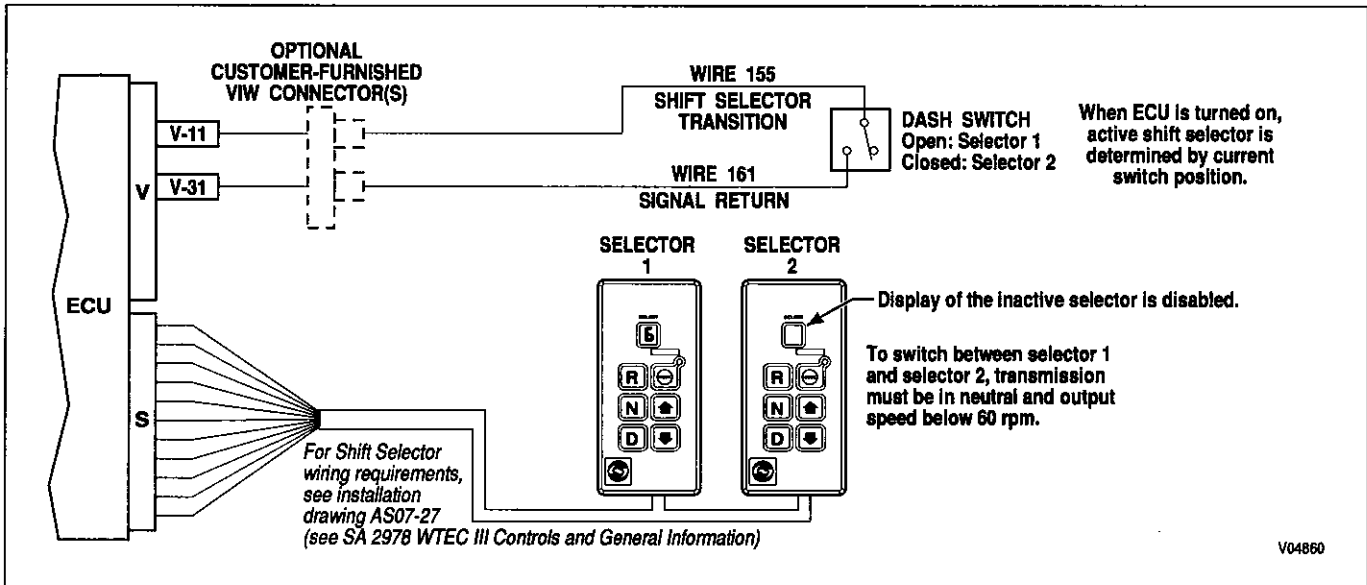

Figure P-6. Shift Selector Transition

APPENDIX P — INPUT/OUTPUT FUNCTIONS

WARNING!

These schematics show the intended use of the specified controls features which have been validated in the configuration shown. Any miswiring or use of these features which differs from that shown could cause unintended selection of range or other unpredictable operation resulting in damage to equipment or property, personal injury, or loss of life. ALLISON TRANSMISSION IS NOT LIABLE FOR THE CONSEQUENCES ASSOCIATED WITH MISWIRING OR UNINTENDED USE OF THESE FEATURES.

AUXILIARY FUNCTION RANGE INHIBIT (STANDARD)

USES: Prevents inadvertent range selection when auxiliary equipment is operating or prevents engagement of the transmission unless brake pedal is depressed.

VARIABLES TO SPECIFY: None

VOCATIONS: Transit bus, school bus — auxiliary equipment input; various (brake pedal input)

WARNING!

If this function is enabled in the shift calibration, the function **MUST** be integrated into the vehicle wiring. If the function is available in the shift calibration but will not be used in the vehicle, it **MUST** be disabled in the calibration.

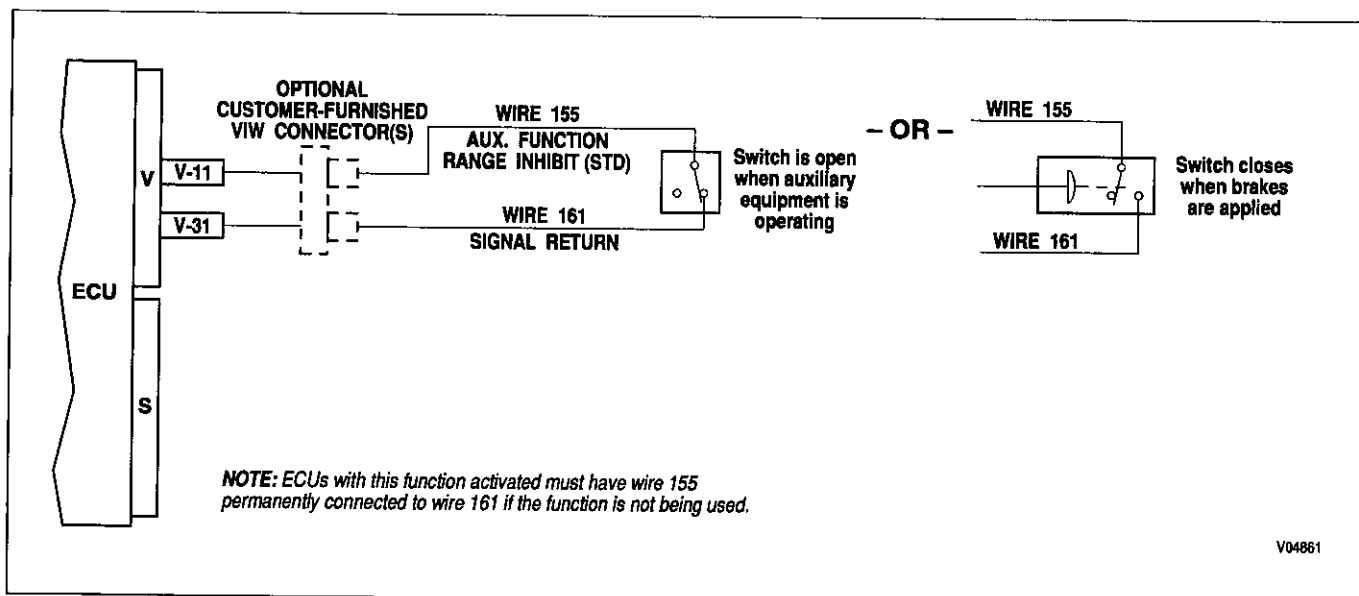

Figure P-7. Auxiliary Function Range Inhibit (Standard)

APPENDIX P — INPUT/OUTPUT FUNCTIONS

WARNING!

These schematics show the intended use of the specified controls features which have been validated in the configuration shown. Any miswiring or use of these features which differs from that shown could cause unintended selection of range or other unpredictable operation resulting in damage to equipment or property, personal injury, or loss of life. ALLISON TRANSMISSION IS NOT LIABLE FOR THE CONSEQUENCES ASSOCIATED WITH MISWIRING OR UNINTENDED USE OF THESE FEATURES.

AUXILIARY FUNCTION RANGE INHIBIT (SPECIAL)

USES: Prevents inadvertent range selection when auxiliary equipment is operating. Used in emergency equipment to prevent inadvertent range selection from NEUTRAL.

VARIABLES TO SPECIFY: None

VOCATIONS: Fire trucks, crash trucks

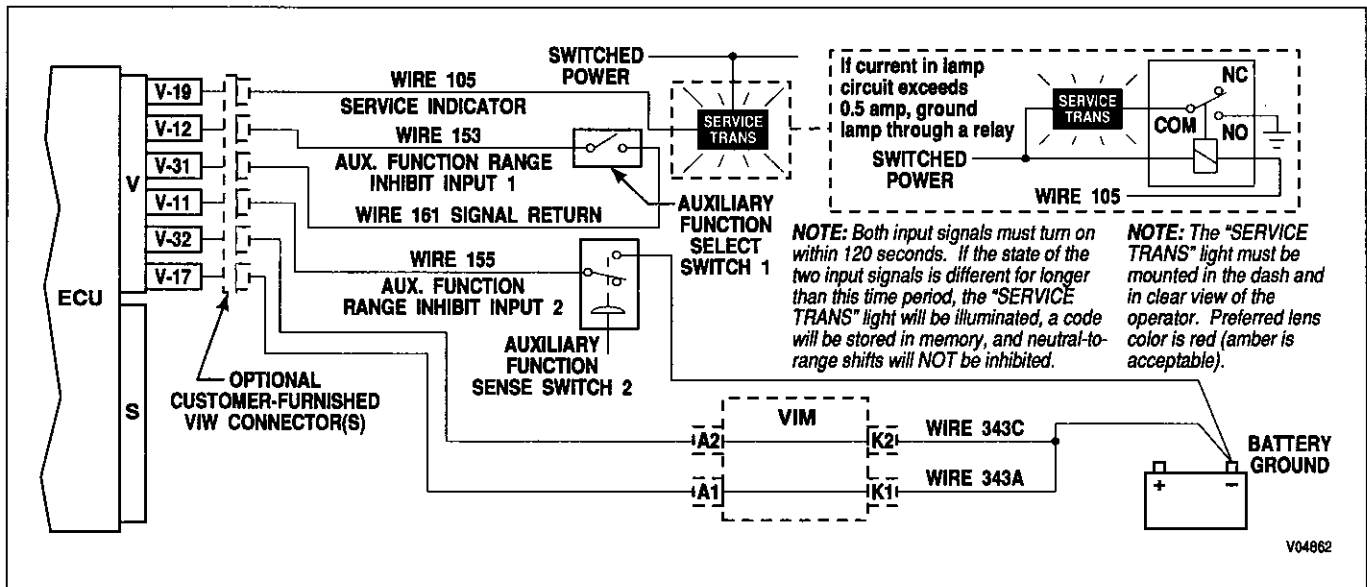

Figure P-8. Auxiliary Function Range Inhibit (Special)

APPENDIX P — INPUT/OUTPUT FUNCTIONS

WARNING!

These schematics show the intended use of the specified controls features which have been validated in the configuration shown. Any miswiring or use of these features which differs from that shown could result in damage to equipment or property, personal injury, or loss of life. ALLISON TRANSMISSION IS NOT LIABLE FOR THE CONSEQUENCES ASSOCIATED WITH MISWIRING OR UNINTENDED USE OF THESE FEATURES.

AUXILIARY HOLD

USES: Provide a discrete input to hold the transmission in present range.

VARIABLES TO SPECIFY: None

VOCATIONS: Various

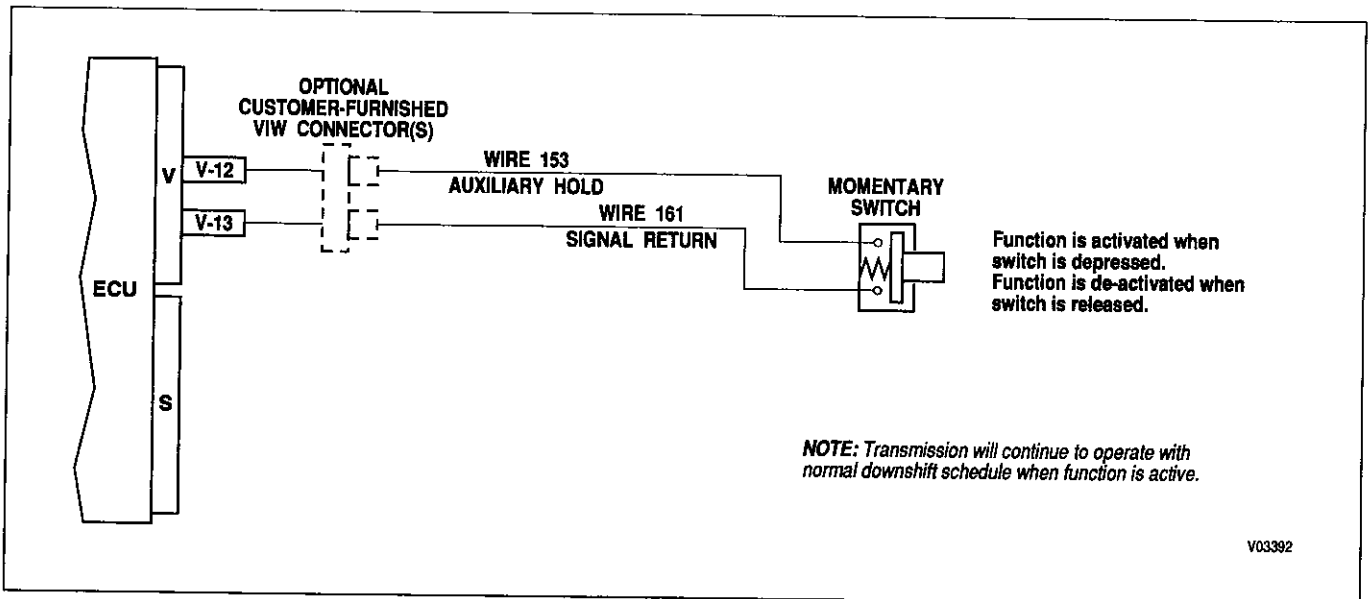

Figure P-9. Auxiliary Hold

APPENDIX P — INPUT/OUTPUT FUNCTIONS

WARNING!

These schematics show the intended use of the specified controls features which have been validated in the configuration shown. Any miswiring or use of these features which differs from that shown could result in damage to equipment or property, personal injury, or loss of life. ALLISON TRANSMISSION IS NOT LIABLE FOR THE CONSEQUENCES ASSOCIATED WITH MISWIRING OR UNINTENDED USE OF THESE FEATURES.

ENGINE BRAKE/PRESELECT REQUEST AND ENGINE BRAKE ENABLE (EXHAUST BRAKE)

USES: Used with engine brakes to signal the ECU that the brake is active and to provide increased braking by preselecting a lower range. Also prevents engagement of engine brake with throttle > 0 or lockup OFF.

VARIABLES TO SPECIFY: Preselect range. Standard value is second range.

VOCATIONS: Various

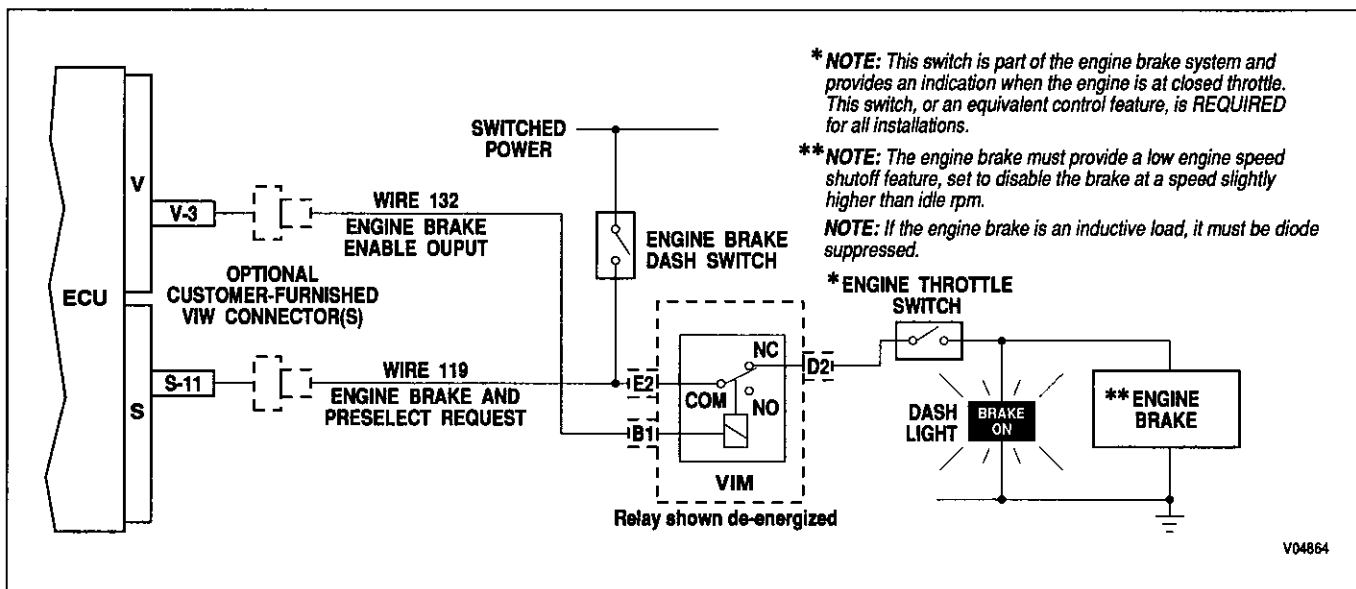

Figure P-10. Engine Brake/Preselect Request and Engine Brake Enable (Exhaust Brake)

APPENDIX P — INPUT/OUTPUT FUNCTIONS

WARNING!

These schematics show the intended use of the specified controls features which have been validated in the configuration shown. Any miswiring or use of these features which differs from that shown could result in damage to equipment or property, personal injury, or loss of life. ALLISON TRANSMISSION IS NOT LIABLE FOR THE CONSEQUENCES ASSOCIATED WITH MISWIRING OR UNINTENDED USE OF THESE FEATURES.

ENGINE BRAKE/PRESELECT REQUEST AND ENGINE BRAKE ENABLE (COMPRESSION BRAKE)

USES: Used with single-level compression brakes to signal the ECU that the brake is active and to provide increased braking by preselecting a lower range. Also prevents engagement of engine brake with throttle > 0 or lockup OFF.

VARIABLES TO SPECIFY: Preselect range. Standard value is fourth range.

VOCATIONS: Various

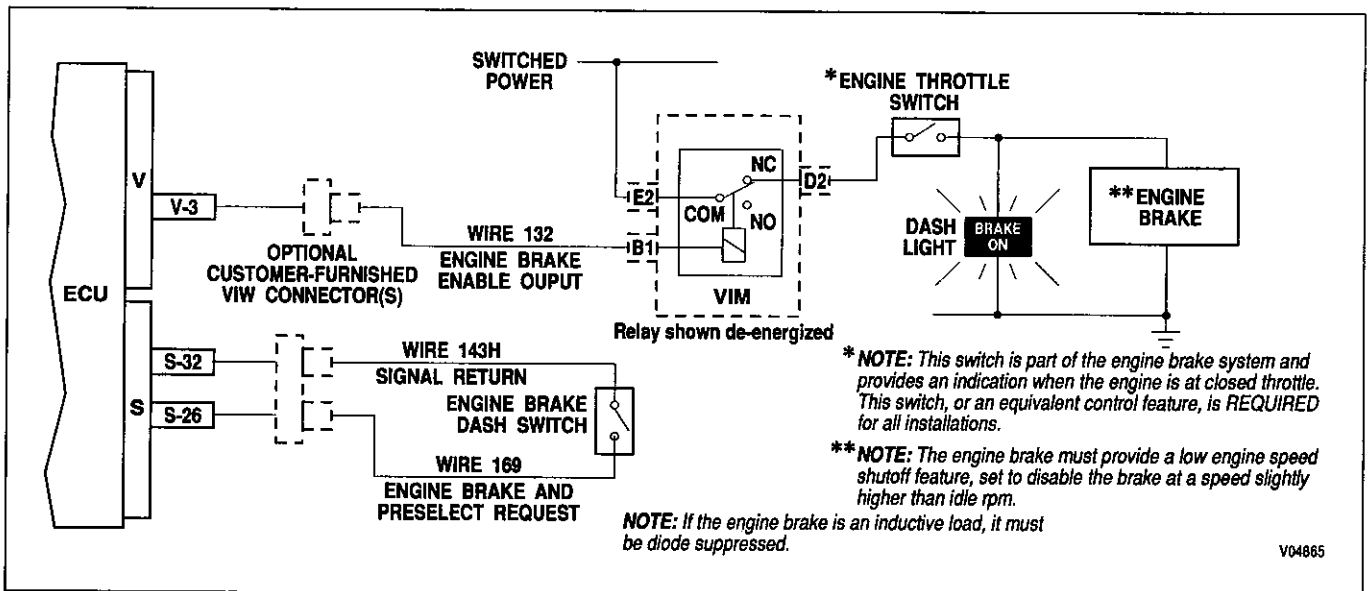

Figure P-11. Engine Brake/Preselect Request and Engine Brake Enable (Compression Brake)

APPENDIX P — INPUT/OUTPUT FUNCTIONS

WARNING!

These schematics show the intended use of the specified controls features which have been validated in the configuration shown. Any miswiring or use of these features which differs from that shown could result in damage to equipment or property, personal injury, or loss of life. ALLISON TRANSMISSION IS NOT LIABLE FOR THE CONSEQUENCES ASSOCIATED WITH MISWIRING OR UNINTENDED USE OF THESE FEATURES.

ENGINE BRAKE AND PRESELECT REQUEST AND ENGINE BRAKE ENABLE (MULTIPLE LEVEL COMPRESSION BRAKE)

USES: Used with multiple-level compression brakes to signal the ECU that the brake is active and to provide increased braking by preselecting a lower range. Also prevents engagement of engine brake with throttle > 0 or lockup OFF.

VARIABLES TO SPECIFY: Preselect range. Standard value is fourth range.

VOCATIONS: Various

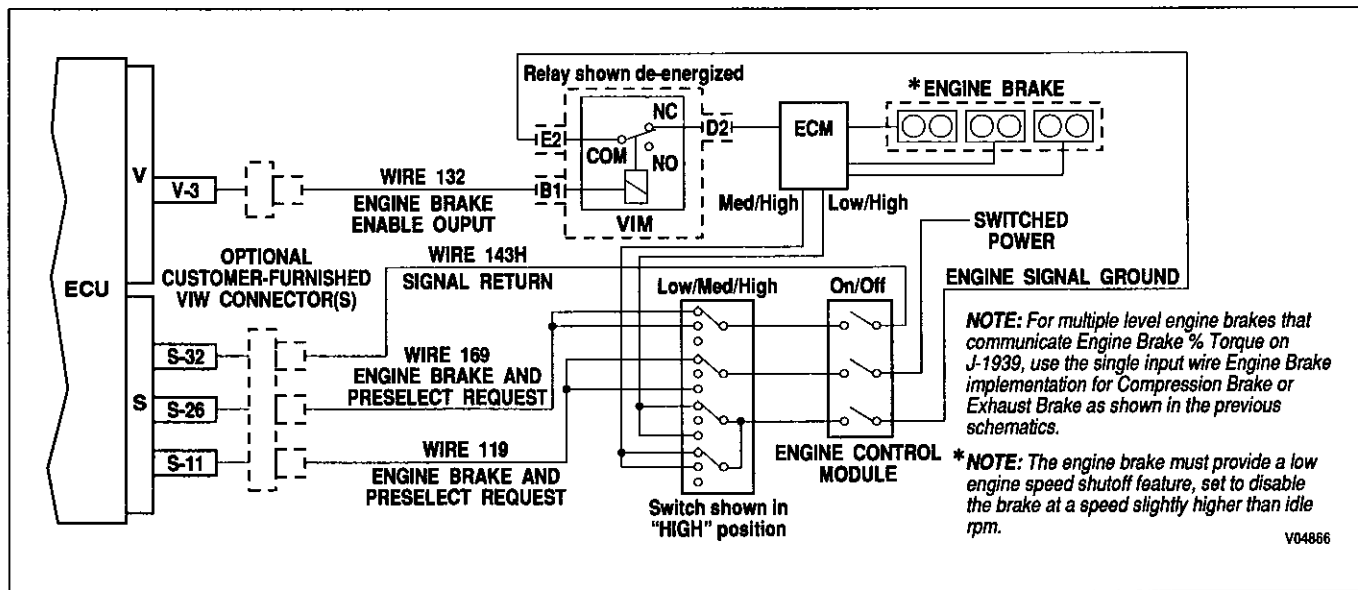

Figure P-12. Engine Brake and Preselect Request and Engine Brake Enable (Multiple Level Compression Brake)

APPENDIX P — INPUT/OUTPUT FUNCTIONS

WARNING!

These schematics show the intended use of the specified controls features which have been validated in the configuration shown. Any miswiring or use of these features which differs from that shown could result in damage to equipment or property, personal injury, or loss of life. ALLISON TRANSMISSION IS NOT LIABLE FOR THE CONSEQUENCES ASSOCIATED WITH MISWIRING OR UNINTENDED USE OF THESE FEATURES.

ENGINE BRAKE/PRESELECT REQUEST AND ENGINE BRAKE ENABLE (EXHAUST BRAKE — SPECIAL)

USES: Used with engine brakes to provide a signal to the ECU that the brake is active and to provide increased braking by preselecting a lower range. Also prevents engagement of engine brake with throttle > 0 or lockup OFF.

VARIABLES TO SPECIFY: Preselect range. Standard value is second range.

VOCATIONS: Various

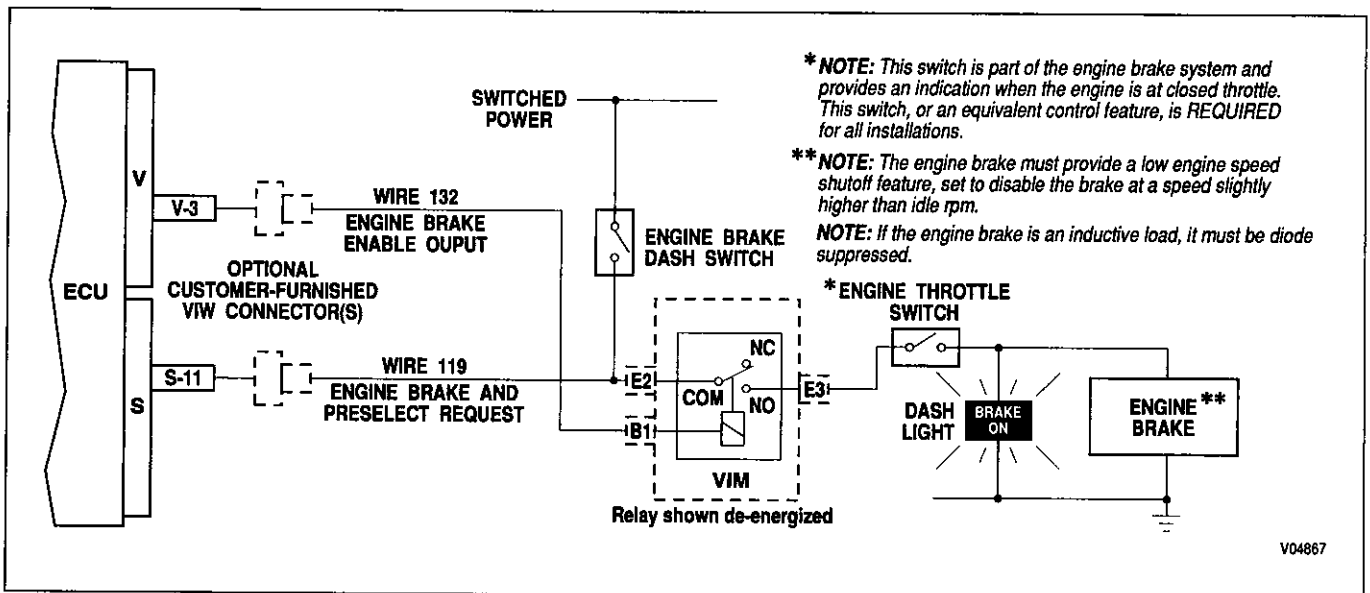

Figure P-13. Engine Brake/Preselect Request and Engine Brake Enable (Exhaust Brake — Special)

APPENDIX P — INPUT/OUTPUT FUNCTIONS

WARNING!

These schematics show the intended use of the specified controls features which have been validated in the configuration shown. Any miswiring or use of these features which differs from that shown could result in damage to equipment or property, personal injury, or loss of life. ALLISON TRANSMISSION IS NOT LIABLE FOR THE CONSEQUENCES ASSOCIATED WITH MISWIRING OR UNINTENDED USE OF THESE FEATURES.

ENGINE BRAKE/PRESELECT REQUEST AND ENGINE BRAKE ENABLE (COMPRESSION BRAKE — SPECIAL)

USES: Used with engine brakes to provide a signal to the ECU that the brake is active and to provide increased braking by preselecting a lower range. Also prevents engagement of engine brake with throttle > 0 or lockup off.

VARIABLES TO SPECIFY: Preselect range. Standard value is fourth range.

VOCATIONS: Various

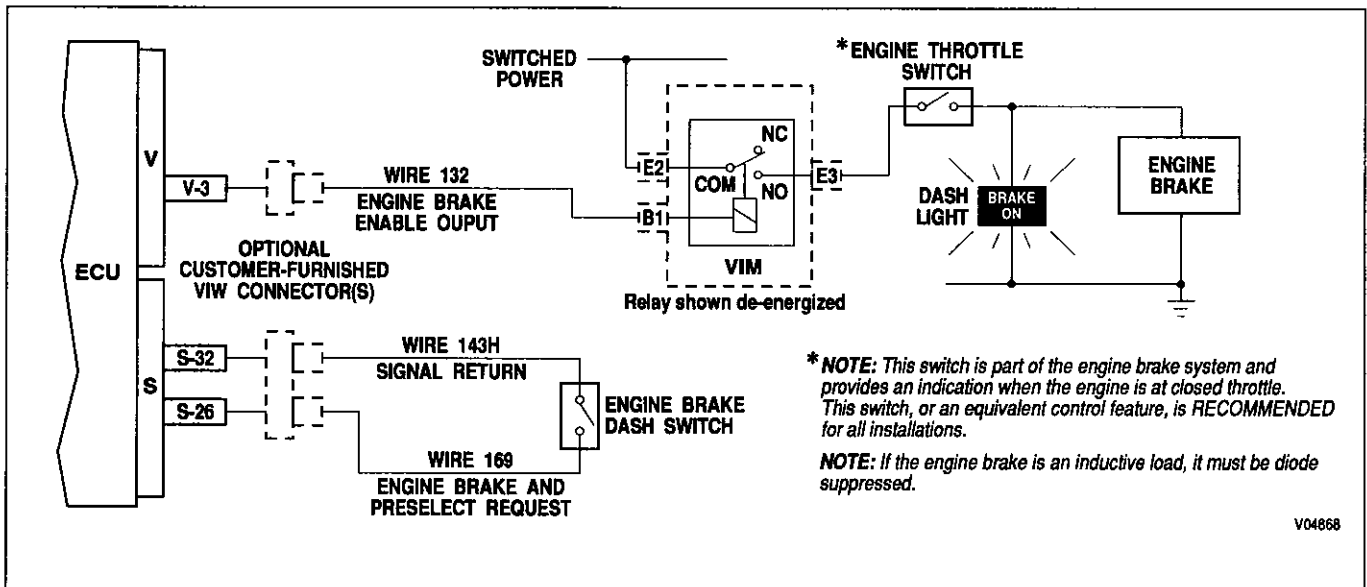

Figure P-14. Engine Brake/Preselect Request and Engine Brake Enable (Compression Brake — Special)

APPENDIX P — INPUT/OUTPUT FUNCTIONS

WARNING!

These schematics show the intended use of the specified controls features which have been validated in the configuration shown. Any miswiring or use of these features which differs from that shown could result in damage to equipment or property, personal injury, or loss of life. ALLISON TRANSMISSION IS NOT LIABLE FOR THE CONSEQUENCES ASSOCIATED WITH MISWIRING OR UNINTENDED USE OF THESE FEATURES.

FIRE TRUCK PUMP MODE

USES: Facilitates engagement of split shaft PTO and shifts transmission to fourth range lockup.

VARIABLES TO SPECIFY: None

VOCATIONS: Fire Truck Pumpers

WARNING!

If this function is enabled in the shift calibration, the function **MUST** be integrated into the vehicle wiring. If the function is available in the shift calibration but will not be used in the vehicle, it **MUST** be disabled in the calibration.

SYSTEM OPERATION

OPERATOR ACTION — System Response

TO ENGAGE:

1. **SELECT NEUTRAL** — Transmission shifts to Neutral.
2. **APPLY PARKING BRAKE** — None
3. **SELECT PUMP** — Turns on “Pump Mode Requested” light. Stops output shaft rotation. When split-shaft engages, PPE signal and “Pump Engaged” light are turned on. Transmission output unlocks.
4. **SELECT DRIVE** — Transmission shifts to fourth lockup. “OK To Pump” light is turned on.

TO DISENGAGE:

1. **SELECT NEUTRAL** — Transmission shifts to Neutral if output rpm < 1000.
2. **SELECT ROAD MODE** — Stops output shaft rotation. PTO disengages. Transmission shifts back to Neutral. If the output shaft rotation continues, press the momentary transmission brake switch before selecting road mode. This will cause the transmission output shaft to stop if transmission is in neutral and shaft rotation is less than 100 rpm.

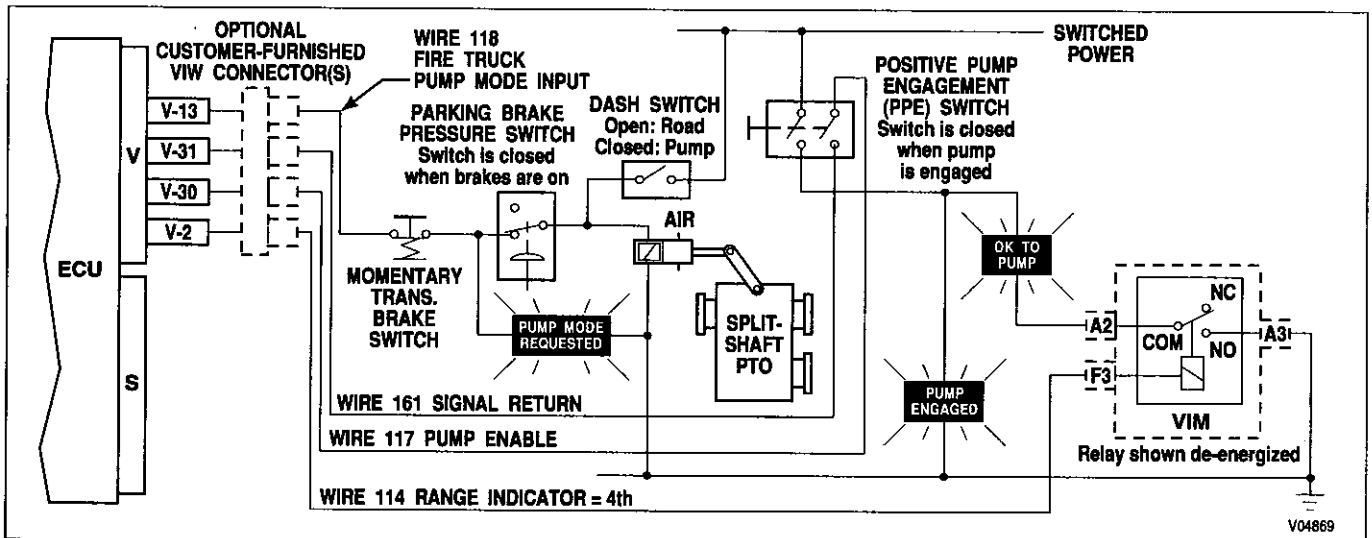

Figure P-15. Fire Truck Pump Mode

APPENDIX P — INPUT/OUTPUT FUNCTIONS

WARNING!

These schematics show the intended use of the specified controls features which have been validated in the configuration shown. Any miswiring or use of these features which differs from that shown could result in damage to equipment or property, personal injury, or loss of life. ALLISON TRANSMISSION IS NOT LIABLE FOR THE CONSEQUENCES ASSOCIATED WITH MISWIRING OR UNINTENDED USE OF THESE FEATURES.

FIRE TRUCK PUMP MODE (OPTIONAL)

USES: Facilitates engagement of split shaft PTO and shifts transmission to fourth range lockup.

VARIABLES TO SPECIFY: None

VOCATIONS: Fire Truck Pumpers

WARNING!

If this function is enabled in the shift calibration, the function **MUST** be integrated into the vehicle wiring. If the function is available in the shift calibration but will not be used in the vehicle, it **MUST** be disabled in the calibration.

SYSTEM OPERATION

OPERATOR ACTION — System Response

TO ENGAGE:

1. SELECT NEUTRAL — Transmission shifts to Neutral.
2. APPLY PARKING BRAKE — None
3. SELECT PUMP — Turns on “Pump Mode Requested” light. Turns on both input signals to ECU (wires 117 and 118) which activates “fire truck” mode. When split-shaft shifts, “Pump Engaged” light is turned on.
4. SELECT DRIVE — Transmission shifts to fourth lockup. “OK To Pump” light is turned on.

TO DISENGAGE:

1. SELECT NEUTRAL — Transmission shifts to Neutral if output rpm < 1000.
2. SELECT ROAD MODE — PTO disengages. If the output shaft rotation continues, press the momentary transmission brake switch before selecting road mode. This will cause the transmission output shaft to stop if transmission is in neutral and shaft rotation is less than 100 rpm.

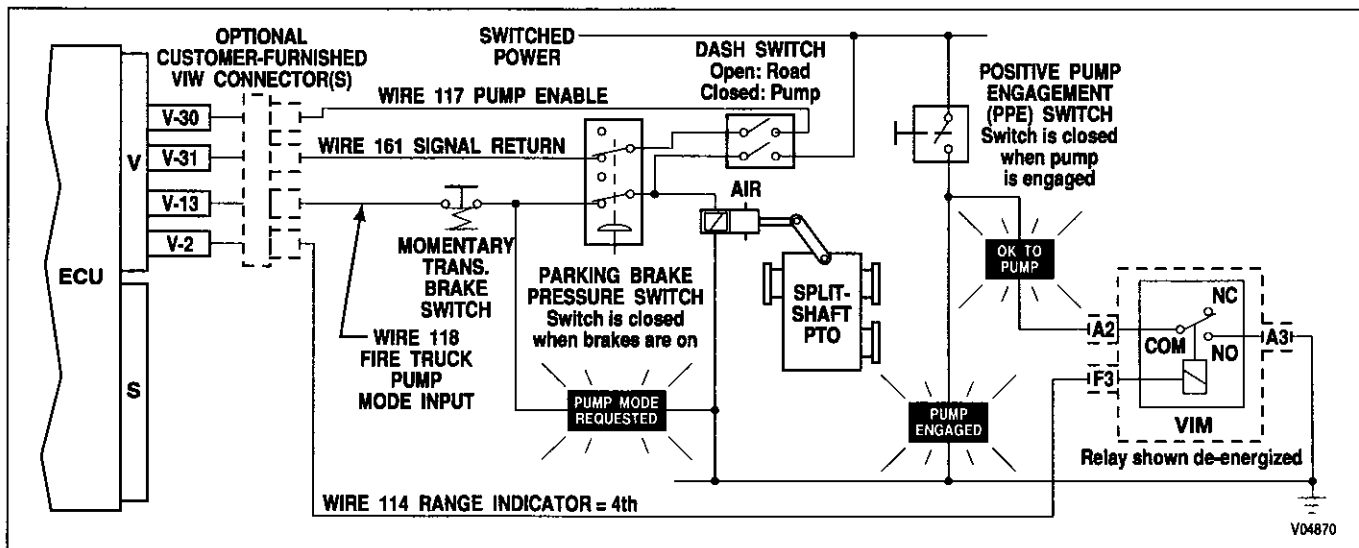

Figure P-16. Fire Truck Pump Mode (Optional)

APPENDIX P — INPUT/OUTPUT FUNCTIONS

WARNING!

These schematics show the intended use of the specified controls features which have been validated in the configuration shown. Any miswiring or use of these features which differs from that shown could cause unintended selection of range or other unpredictable operation resulting in damage to equipment or property, personal injury, or loss of life. **ALLISON TRANSMISSION IS NOT LIABLE FOR THE CONSEQUENCES ASSOCIATED WITH MISWIRING OR UNINTENDED USE OF THESE FEATURES.**

QUICK-TO-NEUTRAL PUMP

USES: Automatically shifts transmission to NEUTRAL when pumped medium approaches excessive pressure levels.

VARIABLES TO SPECIFY: None

VOCATIONS: Oil field pumping

WARNING!

If this function is enabled in the shift calibration, the function **MUST** be integrated into the vehicle wiring. If the function is available in the shift calibration but will not be used in the vehicle, it **MUST** be disabled in the calibration.

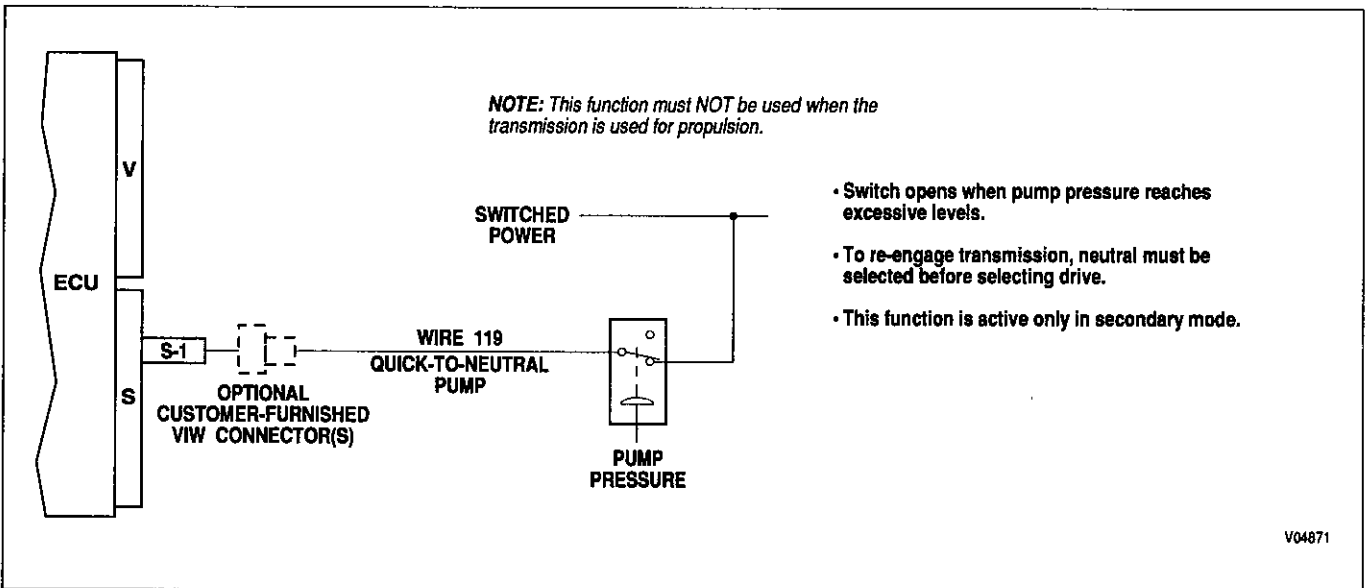

Figure P-17. Quick-To-Neutral Pump

APPENDIX P — INPUT/OUTPUT FUNCTIONS

WARNING!

These schematics show the intended use of the specified controls features which have been validated in the configuration shown. Any miswiring or use of these features which differs from that shown could cause unintended selection of range or other unpredictable operation resulting in damage to equipment or property, personal injury, or loss of life. ALLISON TRANSMISSION IS NOT LIABLE FOR THE CONSEQUENCES ASSOCIATED WITH MISWIRING OR UNINTENDED USE OF THESE FEATURES.

AUTOMATIC NEUTRAL FOR PTO (STANDARD)

USES: Provides for automatic selection of NEUTRAL when PTO is operated regardless of range selected. Requires re-selecting range to shift out of NEUTRAL. Shown with range indicator output.

VARIABLES TO SPECIFY: Maximum output speed for activating this function. Range indicator = neutral.

VOCATIONS: Various (with usage of PTO)

WARNING!

If this function is enabled in the shift calibration, the function **MUST** be integrated into the vehicle wiring. If the function is available in the shift calibration but will not be used in the vehicle, it **MUST** be disabled in the calibration.

This function must not be used with Neutral Indicator For PTO (Output "S").

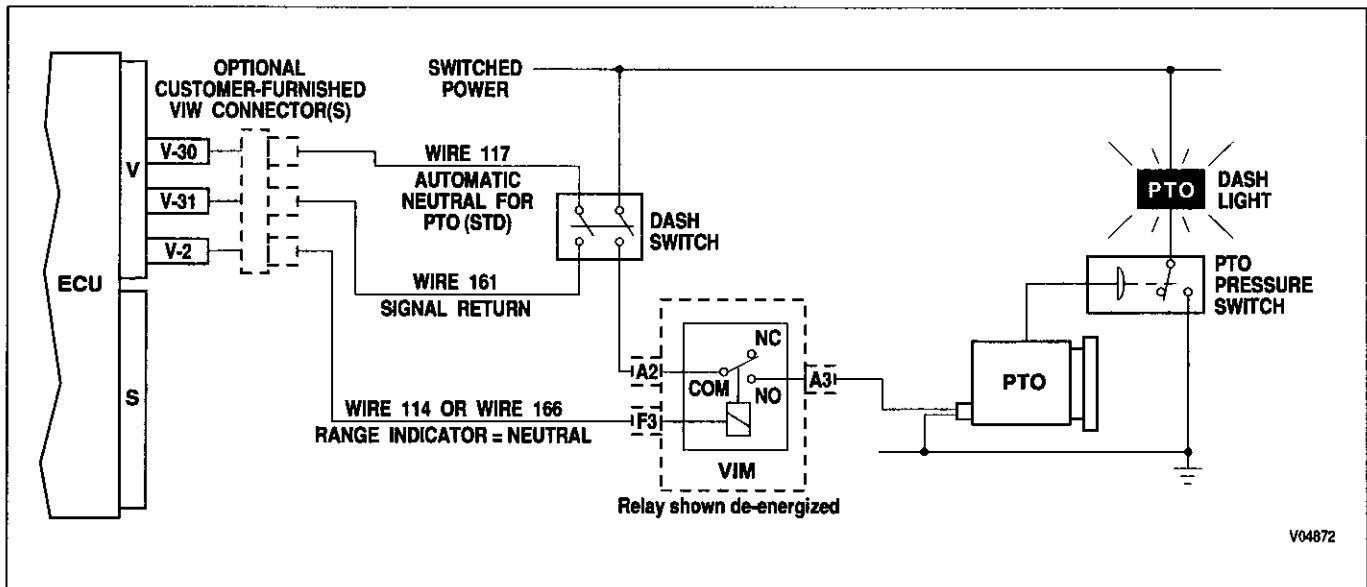

Figure P-18. Automatic Neutral for PTO (Standard)

APPENDIX P — INPUT/OUTPUT FUNCTIONS

WARNING!

These schematics show the intended use of the specified controls features which have been validated in the configuration shown. Any miswiring or use of these features which differs from that shown could cause unintended selection of range or other unpredictable operation resulting in damage to equipment or property, personal injury, or loss of life. ALLISON TRANSMISSION IS NOT LIABLE FOR THE CONSEQUENCES ASSOCIATED WITH MISWIRING OR UNINTENDED USE OF THESE FEATURES.

AUTOMATIC NEUTRAL

USES: Automatically shifts transmission to NEUTRAL when vehicle doors are opened. Re-engages transmission in DRIVE when doors are closed.

VARIABLES TO SPECIFY: None

VOCATIONS: Transit bus

WARNING!

If this function is enabled in the shift calibration, the function **MUST** be integrated into the vehicle wiring. If the function is available in the shift calibration but will not be used in the vehicle, it **MUST** be disabled in the calibration.

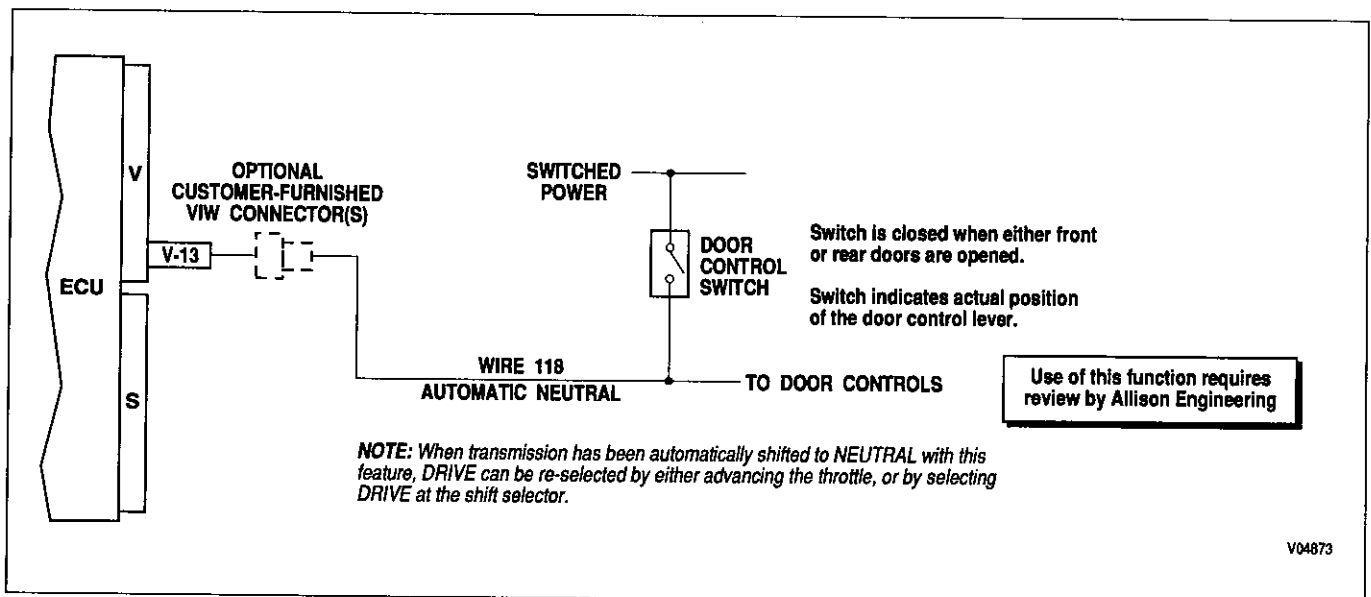

Figure P-19. Automatic Neutral

APPENDIX P — INPUT/OUTPUT FUNCTIONS

WARNING!

These schematics show the intended use of the specified controls features which have been validated in the configuration shown. Any miswiring or use of these features which differs from that shown could result in damage to equipment or property, personal injury, or loss of life. ALLISON TRANSMISSION IS NOT LIABLE FOR THE CONSEQUENCES ASSOCIATED WITH MISWIRING OR UNINTENDED USE OF THESE FEATURES.

TWO SPEED AXLE INPUT AND OUTPUT

USES: Provides output speed interlock for axle engagement, input to ECU, and input to speedometer to adjust for axle ratio change.

VARIABLES TO SPECIFY: Output speed to activate, output speed to deactivate

VOCATIONS: Dump truck, refuse packer, cement mixer, two-speed axle equipped vehicles

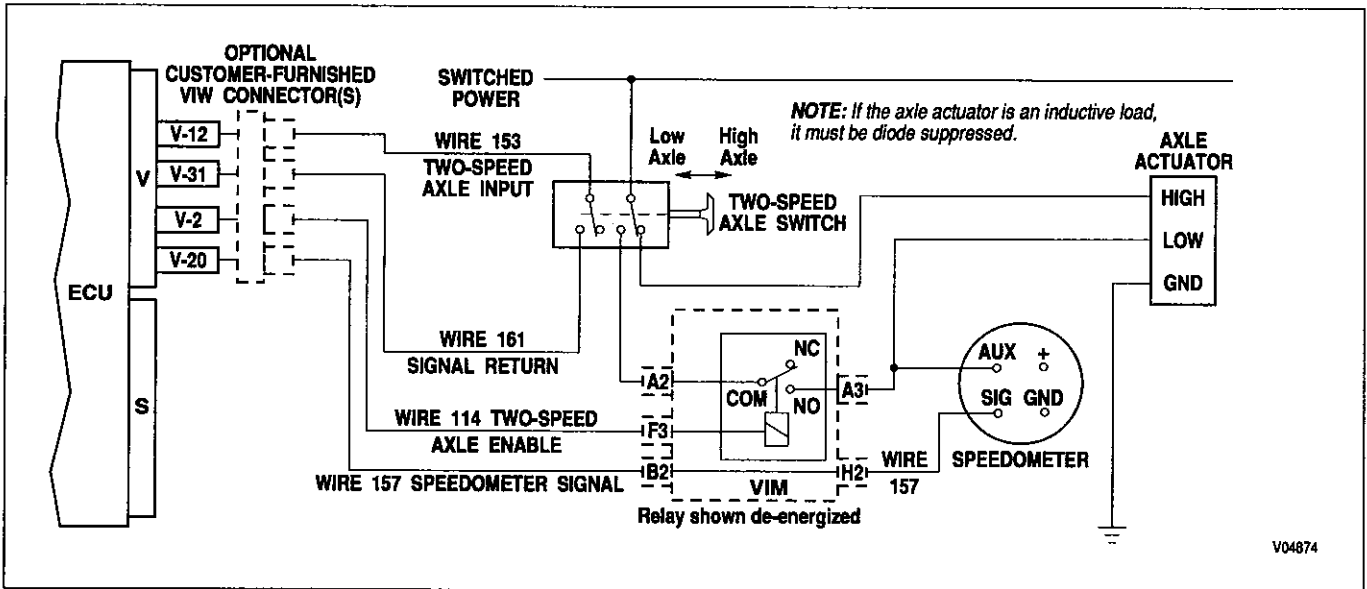

Figure P-20. Two Speed Axle Input and Output

APPENDIX P — INPUT/OUTPUT FUNCTIONS

WARNING!

These schematics show the intended use of the specified controls features which have been validated in the configuration shown. Any miswiring or use of these features which differs from that shown could result in damage to equipment or property, personal injury, or loss of life. ALLISON TRANSMISSION IS NOT LIABLE FOR THE CONSEQUENCES ASSOCIATED WITH MISWIRING OR UNINTENDED USE OF THESE FEATURES.

MANUAL LOCKUP

USES: Provides for the manual application of the lockup clutch for non-riding applications. Uses two inputs: one to select manual versus automatic lockup shift mode, and the second as the switching mechanism to command the lockup clutch on and off.

VARIABLES TO SPECIFY: None

VOCATIONS: Oil field pumping, mud pumps, hoists, drilling

WARNING!

If this function is enabled in the shift calibration, the function **MUST** be integrated into the vehicle wiring. If the function is available in the shift calibration but will not be used in the vehicle, it **MUST** be disabled in the calibration.

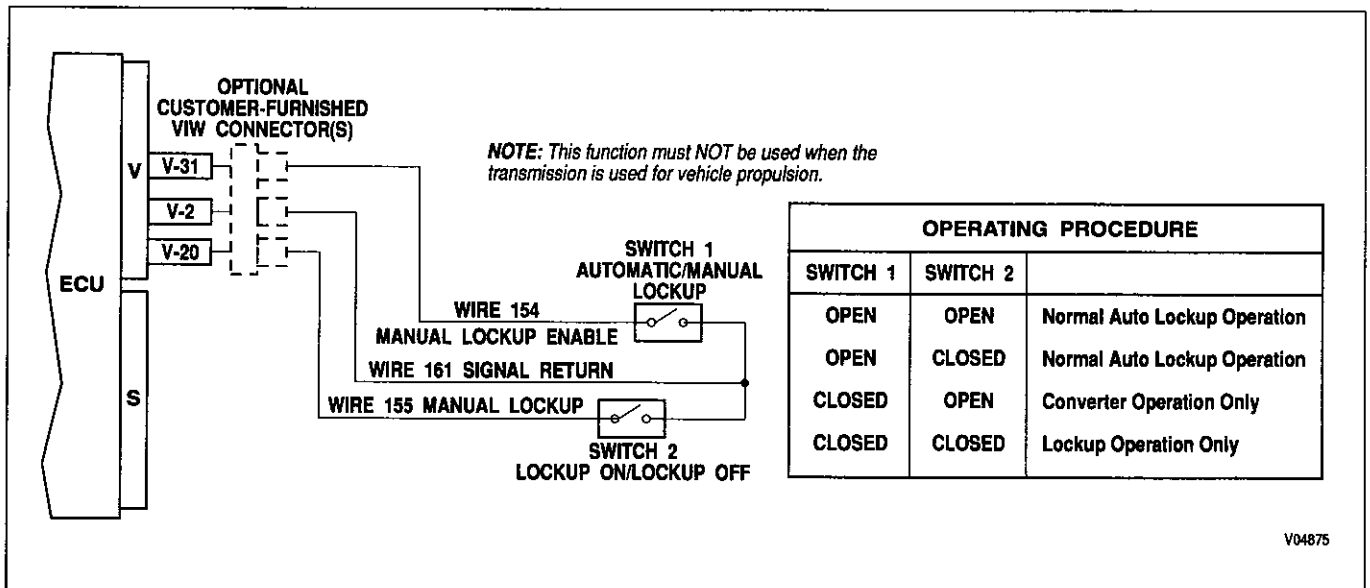

Figure P-21. Manual Lockup

APPENDIX P — INPUT/OUTPUT FUNCTIONS

WARNING!

These schematics show the intended use of the specified controls features which have been validated in the configuration shown. Any miswiring or use of these features which differs from that shown could cause unintended selection of range or other unpredictable operation resulting in damage to equipment or property, personal injury, or loss of life. ALLISON TRANSMISSION IS NOT LIABLE FOR THE CONSEQUENCES ASSOCIATED WITH MISWIRING OR UNINTENDED USE OF THESE FEATURES.

REVERSE ENABLE

USES: Provides for a separate instrument panel-mounted switch which must be pressed simultaneously with the REVERSE button to achieve Reverse.

VARIABLES TO SPECIFY: None

VOCATIONS: European transit buses and tour buses

WARNING!

If this function is enabled in the shift calibration, the function **MUST** be integrated into the vehicle wiring. If the function is available in the shift calibration but will not be used in the vehicle, it **MUST** be disabled in the calibration.

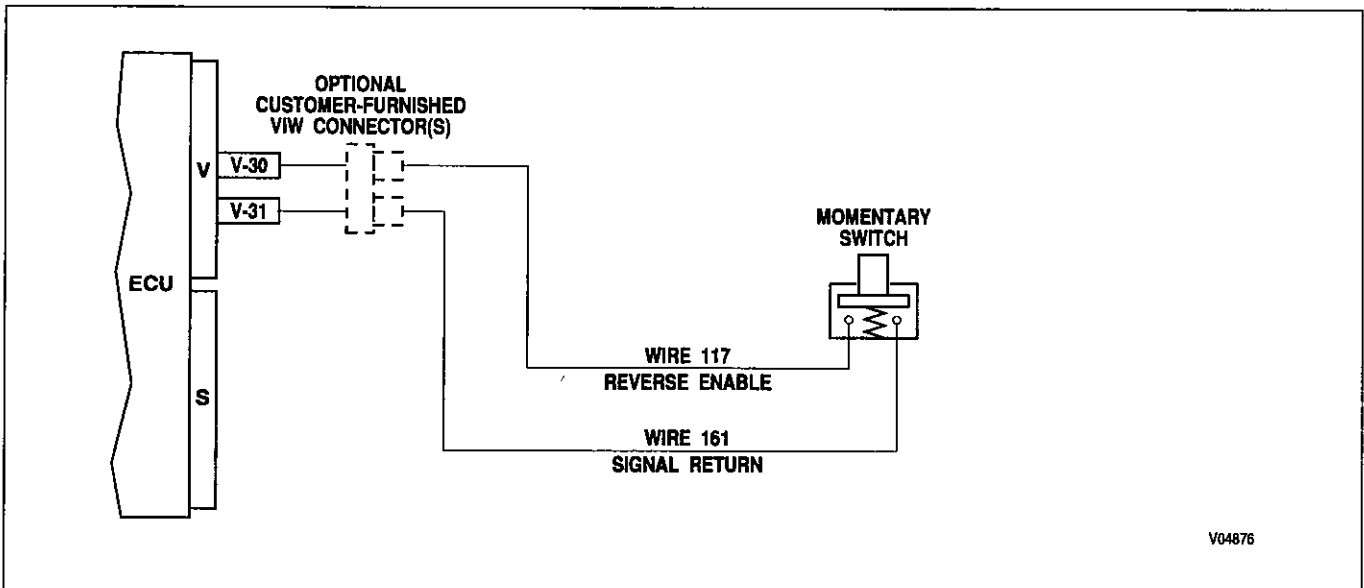

V04876

Figure P-22. Reverse Enable

APPENDIX P — INPUT/OUTPUT FUNCTIONS

WARNING!

These schematics show the intended use of the specified controls features which have been validated in the configuration shown. Any miswiring or use of these features which differs from that shown could result in damage to equipment or property, personal injury, or loss of life. ALLISON TRANSMISSION IS NOT LIABLE FOR THE CONSEQUENCES ASSOCIATED WITH MISWIRING OR UNINTENDED USE OF THESE FEATURES.

SHIFT IN PROCESS/SHIFT ENABLE

USES: Used to reduce engine power during a shift for high horsepower applications.

VARIABLES TO SPECIFY: None

VOCATIONS: Oil field pumping

WARNING!

If this function is enabled in the shift calibration, the function **MUST** be integrated into the vehicle wiring. If the function is available in the shift calibration but will not be used in the vehicle, it **MUST** be disabled in the calibration.

OPERATING PROCEDURE

1. ECU sends signal ("Shift in Process") to powertrain module that a shift is being requested.
2. Powertrain module reduces engine power and sends a signal to ECU ("Shift Enable") indicating that it is OK to shift.
3. ECU commands shift. When shift is completed, "Shift in Process" output turns off.
4. Powertrain module turns off the Shift Enable signal.

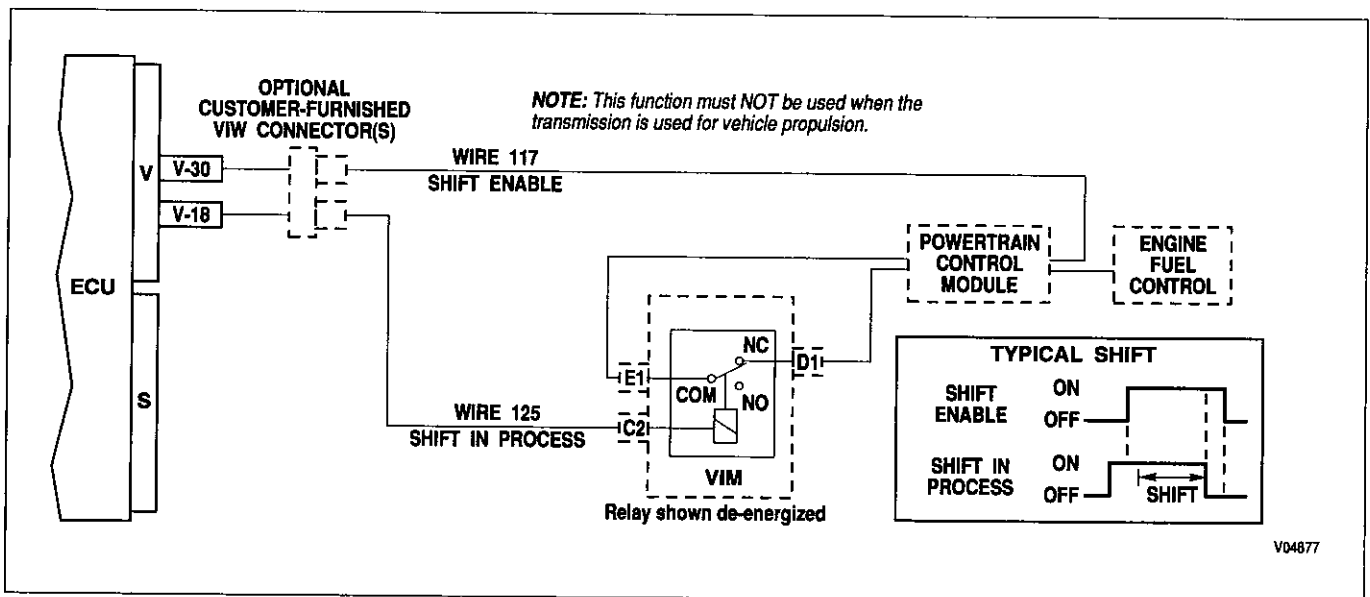

Figure P-23. Shift in Process/Shift Enable

APPENDIX P — INPUT/OUTPUT FUNCTIONS

WARNING!

These schematics show the intended use of the specified controls features which have been validated in the configuration shown. Any miswiring or use of these features which differs from that shown could result in damage to equipment or property, personal injury, or loss of life. ALLISON TRANSMISSION IS NOT LIABLE FOR THE CONSEQUENCES ASSOCIATED WITH MISWIRING OR UNINTENDED USE OF THESE FEATURES.

ANTI-LOCK BRAKE RESPONSE

USES: Signals the ECU when ABS function is active, so that lockup clutch and retarder will be disabled.

VARIABLES TO SPECIFY: None

VOCATIONS: Various

For schematics of this function, see the **ANTI-LOCK BRAKES** section located in Section C: Vehicle Electrical System Interface of SA2978, WTEC III Controls And General Information.

APPENDIX P — INPUT/OUTPUT FUNCTIONS

WARNING!

These schematics show the intended use of the specified controls features which have been validated in the configuration shown. Any miswiring or use of these features which differs from that shown could result in damage to equipment or property, personal injury, or loss of life. ALLISON TRANSMISSION IS NOT LIABLE FOR THE CONSEQUENCES ASSOCIATED WITH MISWIRING OR UNINTENDED USE OF THESE FEATURES.

ANTI-LOCK BRAKE RESPONSE (OPTIONAL)

USES: Provides for enhanced control of lockup and retarder during hard braking conditions. Can be used separately or in conjunction with ABS.

VARIABLES TO SPECIFY: None

VOCATIONS: Various

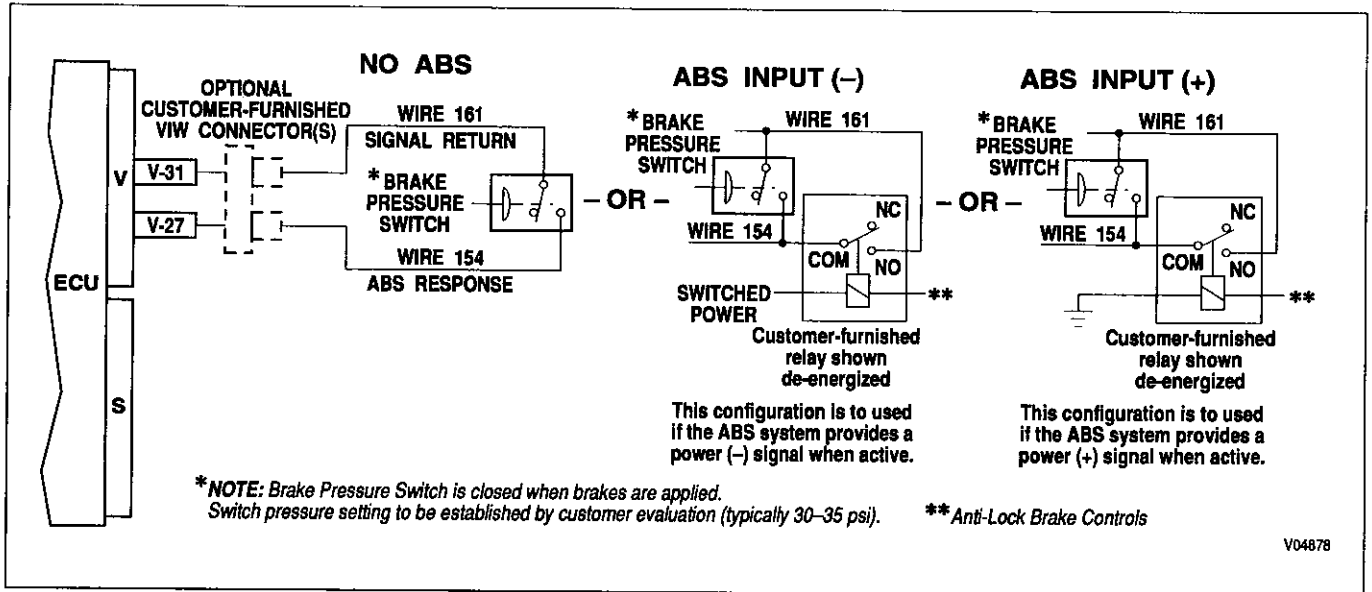

Figure P-24. Anti-Lock Brake Response (Optional)

APPENDIX P — INPUT/OUTPUT FUNCTIONS

WARNING!

These schematics show the intended use of the specified controls features which have been validated in the configuration shown. Any miswiring or use of these features which differs from that shown could result in damage to equipment or property, personal injury, or loss of life. ALLISON TRANSMISSION IS NOT LIABLE FOR THE CONSEQUENCES ASSOCIATED WITH MISWIRING OR UNINTENDED USE OF THESE FEATURES.

RETARDER ENABLE

USES: Provides for operator ON/OFF control of the retarder, transmission temperature indication, and brake lights during retarder operation.

USES: None

VOCATIONS: Various. This function is required for retarder-equipped transmissions.

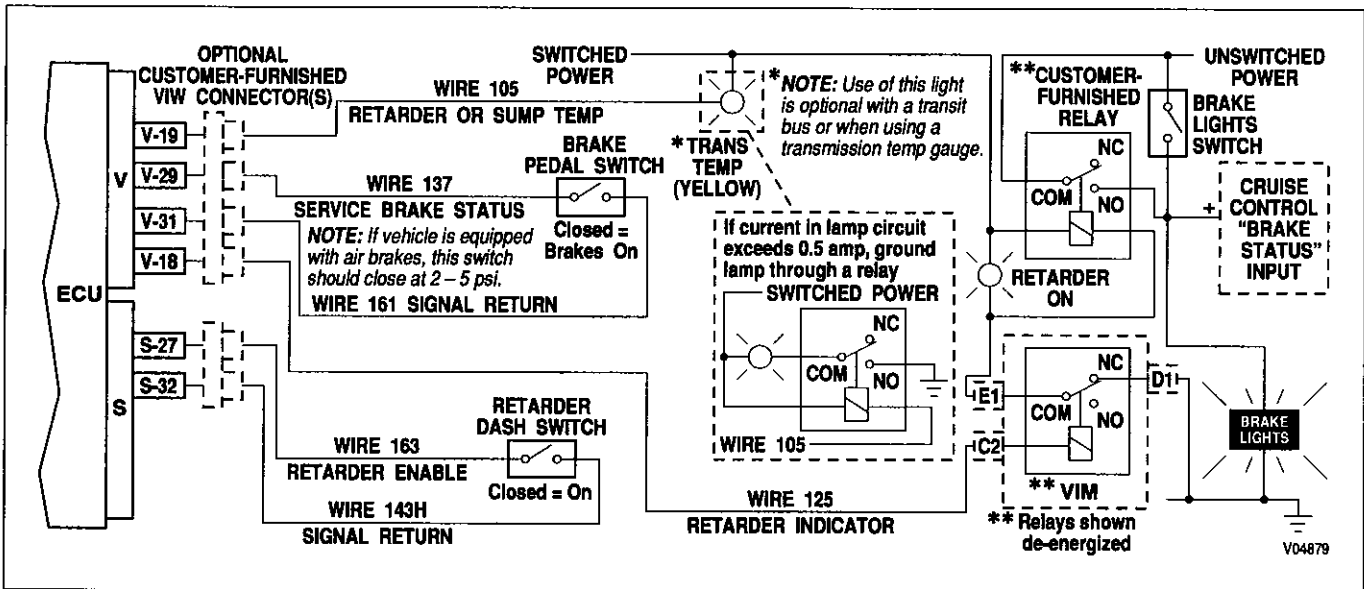

Figure P-25. Retarder Enable

APPENDIX P — INPUT/OUTPUT FUNCTIONS

WARNING!

These schematics show the intended use of the specified controls features which have been validated in the configuration shown. Any miswiring or use of these features which differs from that shown could result in damage to equipment or property, personal injury, or loss of life. ALLISON TRANSMISSION IS NOT LIABLE FOR THE CONSEQUENCES ASSOCIATED WITH MISWIRING OR UNINTENDED USE OF THESE FEATURES.

SERVICE BRAKE STATUS

USES: Indicates to the ECU whether vehicle braking is being provided by the retarder or vehicle brakes, so that the transmission controls can be adapted accordingly.

VARIABLES TO SPECIFY: None

VOCATIONS: Various. This function is **required** for retarder-equipped transmissions.

This function is used in conjunction with Input Function , Retarder Enable. Refer to schematic for Input Function Retarder Enable, noting the use of wire 137.

APPENDIX P — INPUT/OUTPUT FUNCTIONS

WARNING!

These schematics show the intended use of the specified controls features which have been validated in the configuration shown. Any miswiring or use of these features which differs from that shown could result in damage to equipment or property, personal injury, or loss of life. ALLISON TRANSMISSION IS NOT LIABLE FOR THE CONSEQUENCES ASSOCIATED WITH MISWIRING OR UNINTENDED USE OF THESE FEATURES.

DIFFERENTIAL CLUTCH REQUEST

USES: Provides for operator ON/OFF control of the differential locking clutch in the MD 3070PT transmission transfer case.

VARIABLES TO SPECIFY: None

VOCATIONS: Various. This function is **required** for all MD 3070PT transmissions and used only with that model.

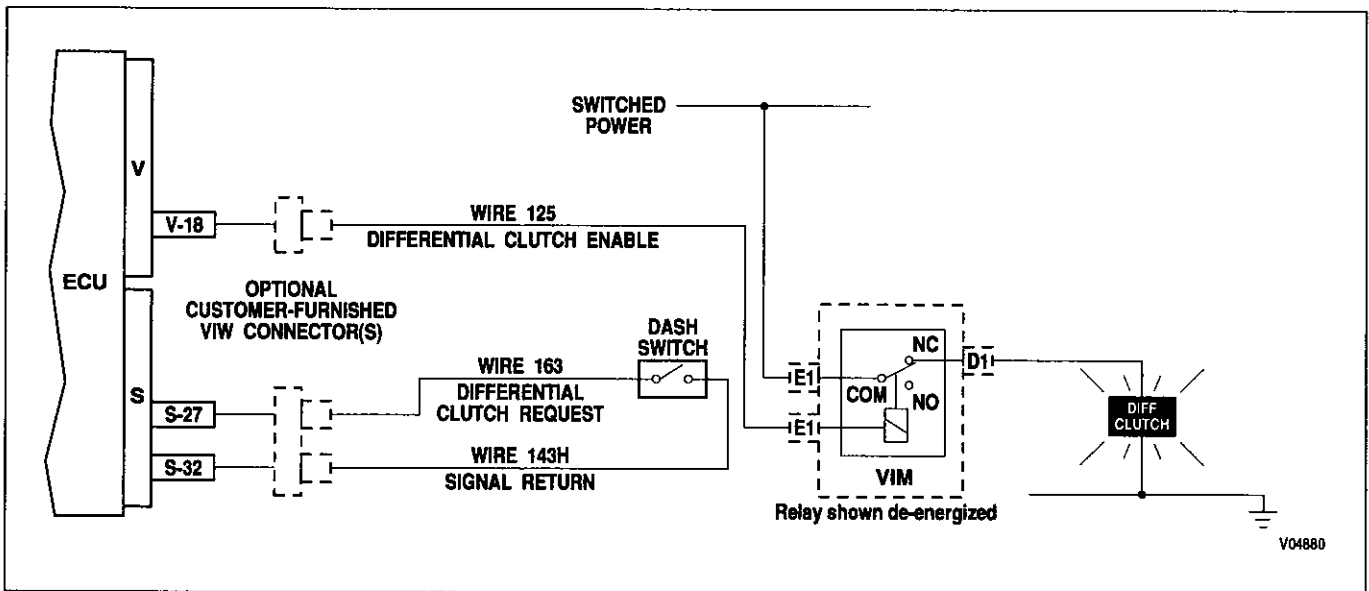

Figure P-26. Differential Clutch Request

APPENDIX P — INPUT/OUTPUT FUNCTIONS

WARNING!

These schematics show the intended use of the specified controls features which have been validated in the configuration shown. Any miswiring or use of these features which differs from that shown could cause unintended selection of range or other unpredictable operation resulting in damage to equipment or property, personal injury, or loss of life. ALLISON TRANSMISSION IS NOT LIABLE FOR THE CONSEQUENCES ASSOCIATED WITH MISWIRING OR UNINTENDED USE OF THESE FEATURES.

AUTOMATIC NEUTRAL FOR REFUSE PACKER AND PTO ENABLE (OPTION 1)

USES: Provides for automatic selection of NEUTRAL and activation of fast idle when park brake is applied. Automatically re-engages transmission when park brake is released. PTO can be enabled independent of transmission range.

VARIABLES TO SPECIFY: Max output rpm to enable Neutral, max engine rpm for PTO engagement, max engine rpm for PTO operation, max output rpm for PTO engagement, max output rpm for PTO operation.

VOCATIONS: Refuse packer, recycling truck

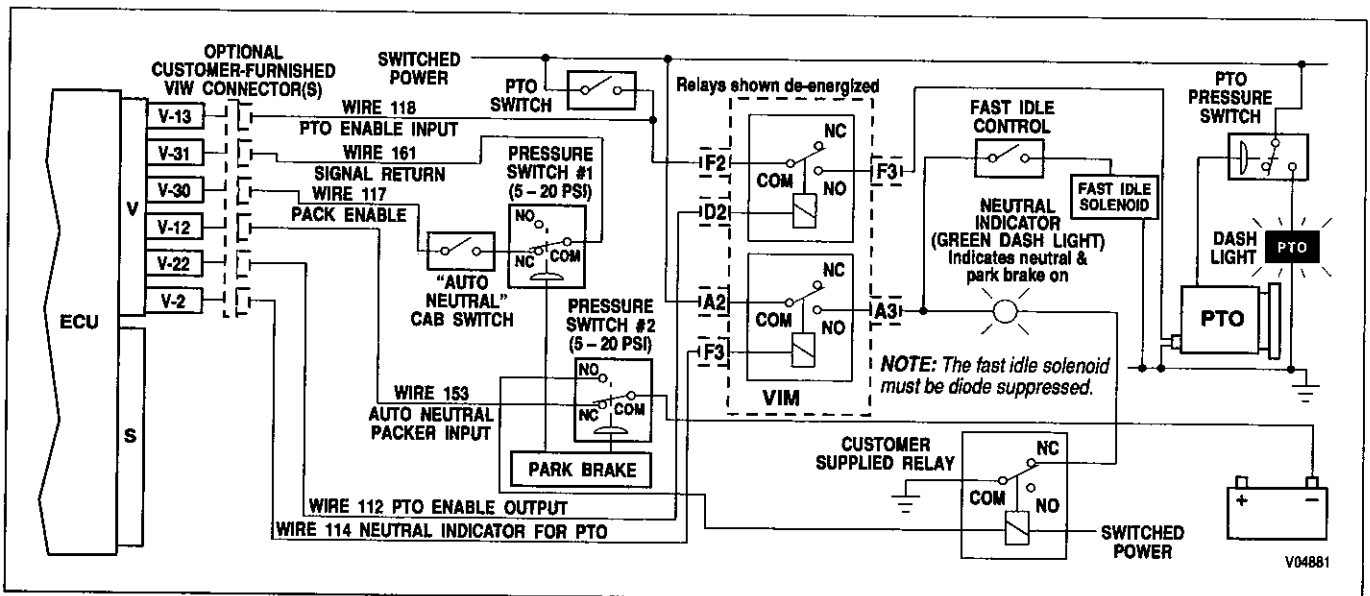

Figure P-27. Automatic Neutral for Refuse Packer and PTO Enable (Option 1)

APPENDIX P — INPUT/OUTPUT FUNCTIONS

WARNING!

These schematics show the intended use of the specified controls features which have been validated in the configuration shown. Any miswiring or use of these features which differs from that shown could cause unintended selection of range or other unpredictable operation resulting in damage to equipment or property, personal injury, or loss of life. ALLISON TRANSMISSION IS NOT LIABLE FOR THE CONSEQUENCES ASSOCIATED WITH MISWIRING OR UNINTENDED USE OF THESE FEATURES.

AUTOMATIC NEUTRAL FOR REFUSE PACKER AND PTO ENABLE (OPTION 2)

USES: Provides for automatic selection of NEUTRAL and activation of fast idle when work brake is applied. Automatically re-engages transmission when park brake is released. PTO can be enabled independent of transmission range.

VARIABLES TO SPECIFY: Max output rpm to enable Neutral, max engine rpm for PTO engagement, max engine rpm for PTO operation, max output rpm for PTO engagement, max output rpm for PTO operation.

VOCATIONS: Refuse packer, recycling truck

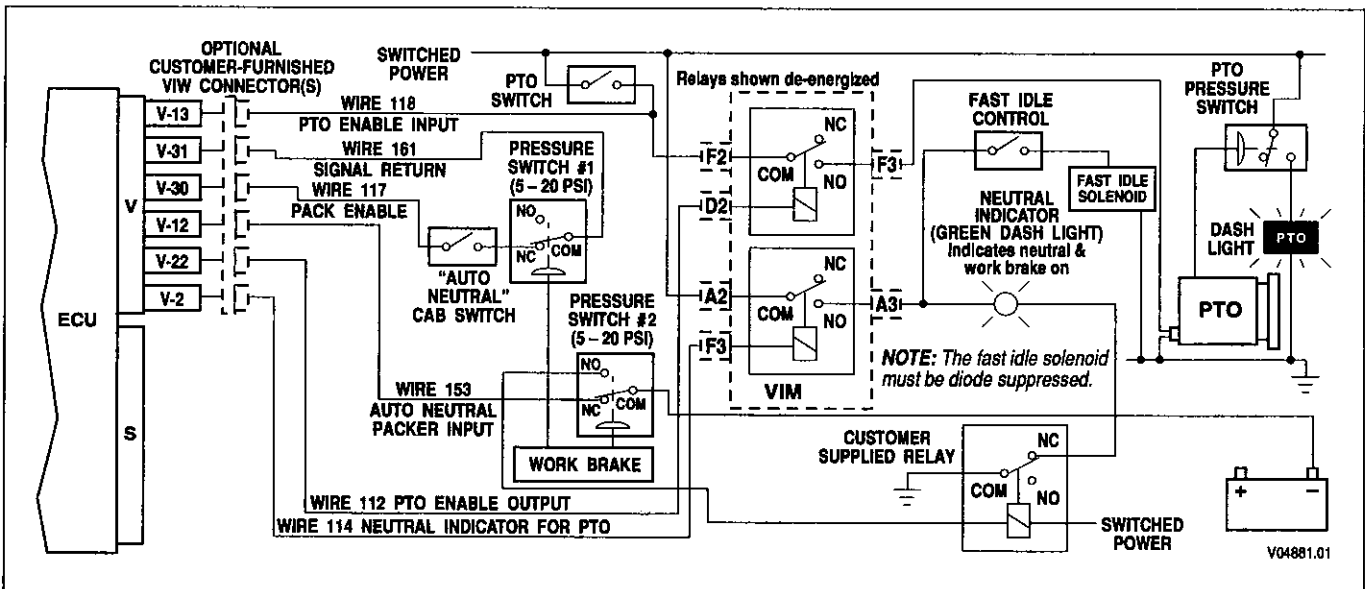

Figure P-28. Automatic Neutral for Refuse Packer and PTO Enable (Option 2)

APPENDIX P — INPUT/OUTPUT FUNCTIONS

WARNING!

These schematics show the intended use of the specified controls features which have been validated in the configuration shown. Any miswiring or use of these features which differs from that shown could result in damage to equipment or property, personal injury, or loss of life. ALLISON TRANSMISSION IS NOT LIABLE FOR THE CONSEQUENCES ASSOCIATED WITH MISWIRING OR UNINTENDED USE OF THESE FEATURES.

KICKDOWN

USES: Provides both economy and performance shift points at full throttle. Operator changes from economy to performance by stepping through a detent at the throttle pedal.

VARIABLES TO SPECIFY: None

VOCATIONS: Various

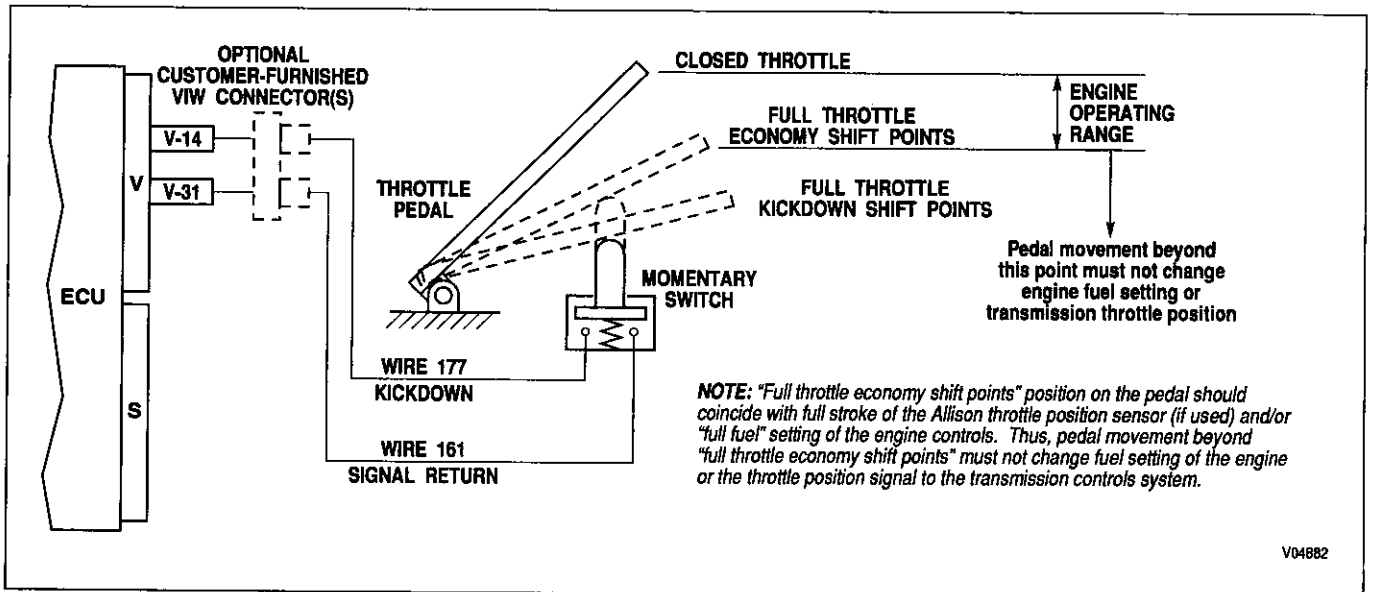

Figure P-29. Kickdown

APPENDIX P — INPUT/OUTPUT FUNCTIONS

WARNING!

These schematics show the intended use of the specified controls features which have been validated in the configuration shown. Any miswiring or use of these features which differs from that shown could result in damage to equipment or property, personal injury, or loss of life. ALLISON TRANSMISSION IS NOT LIABLE FOR THE CONSEQUENCES ASSOCIATED WITH MISWIRING OR UNINTENDED USE OF THESE FEATURES.

MILITARY AUXILIARY FUNCTION RANGE INHIBIT (STANDARD)

USES: Prevents inadvertent range selection when auxiliary equipment is operating.

VARIABLES TO SPECIFY: None

VOCATIONS: Military wheeled vehicles

WARNING!

If this function is turned "ON" in the shift calibration, the function MUST be integrated into the vehicle wiring. If the function is available in the shift calibration but will not be used in the vehicle, it MUST be turned "OFF" in the calibration.

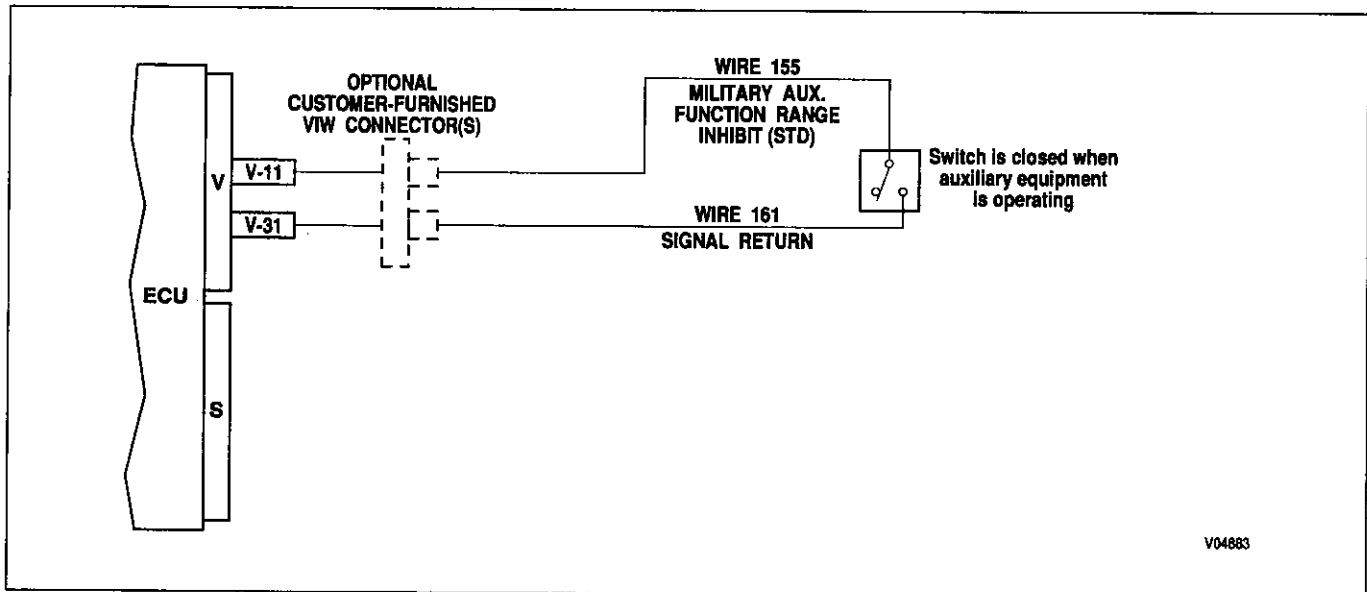

Figure P-30. Military Auxiliary Function Range Inhibit (Standard)

APPENDIX P — INPUT/OUTPUT FUNCTIONS

WARNING!

These schematics show the intended use of the specified controls features which have been validated in the configuration shown. Any miswiring or use of these features which differs from that shown could result in damage to equipment or property, personal injury, or loss of life. ALLISON TRANSMISSION IS NOT LIABLE FOR THE CONSEQUENCES ASSOCIATED WITH MISWIRING OR UNINTENDED USE OF THESE FEATURES.

FOURTH LOCKUP PUMP MODE

USES: Facilitates engagement of split shaft PTO and shifts transmission to fourth range lockup for driving a vehicle-mounted pump.

VARIABLES TO SPECIFY: None

VOCATIONS: Street cleaners, sewer cleaners

WARNING!

If this function is turned "ON" in the shift calibration, the function **MUST** be integrated into the vehicle wiring. If the function is available in the shift calibration but will not be used in the vehicle, it **MUST** be turned "OFF" in the calibration.

SYSTEM OPERATION

OPERATOR ACTION — System Response

TO ENGAGE:

1. **SELECT NEUTRAL** — Transmission shifts to Neutral.
2. **APPLY PARKING BRAKE** — None
3. **SELECT PUMP** — Turns on "Pump Mode Requested" light. Turns on both input signals to ECU (wires 117 and 118) which activates "pump" mode. When split-shaft shifts, "Pump Engaged" light is turned on.
4. **SELECT DRIVE** — Transmission shifts to fourth lockup. "OK To Pump" light is turned on.

TO DISENGAGE:

1. **SELECT NEUTRAL** — Transmission shifts to Neutral if output rpm < 1000.
2. **SELECT ROAD MODE** — PTO disengages.

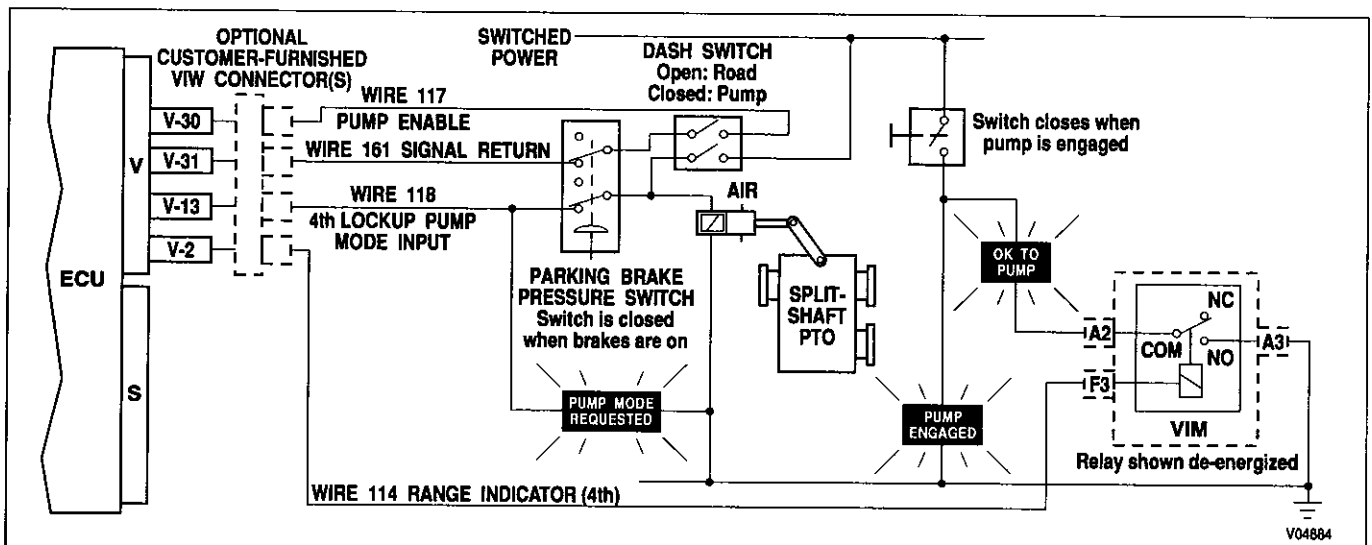

Figure P-31. Fourth Lockup Pump Mode

APPENDIX P — INPUT/OUTPUT FUNCTIONS

WARNING!

These schematics show the intended use of the specified controls features which have been validated in the configuration shown. Any miswiring or use of these features which differs from that shown could cause unintended selection of range or other unpredictable operation resulting in damage to equipment or property, personal injury, or loss of life. ALLISON TRANSMISSION IS NOT LIABLE FOR THE CONSEQUENCES ASSOCIATED WITH MISWIRING OR UNINTENDED USE OF THESE FEATURES.

AUTOMATIC NEUTRAL FOR REFUSE PACKER AND PTO ENABLE WITH SERVICE BRAKE STATUS (OPTION 1)

USES: Provides for automatic selection of NEUTRAL and activation of fast idle when loading arm is activated. Automatically re-engages transmission when loading arm is retracted if service brake is depressed.

VARIABLES TO SPECIFY: Max output rpm to enable Neutral, max engine rpm for PTO engagement, max engine rpm for PTO operation, max output rpm for PTO engagement, max output rpm for PTO operation.

VOCATIONS: Refuse packer, recycling truck

WARNING!

This feature is meant to be used in applications where the vehicle operator remains in the cab. If the operator leaves the vehicle, the park brake must be engaged and Neutral must be selected prior to the operator exiting the cab. In addition, vehicles using this feature must have the following Warning sticker visible in the vehicle cab: "WARNING: Set Park Brake and select Neutral before exiting cab!"

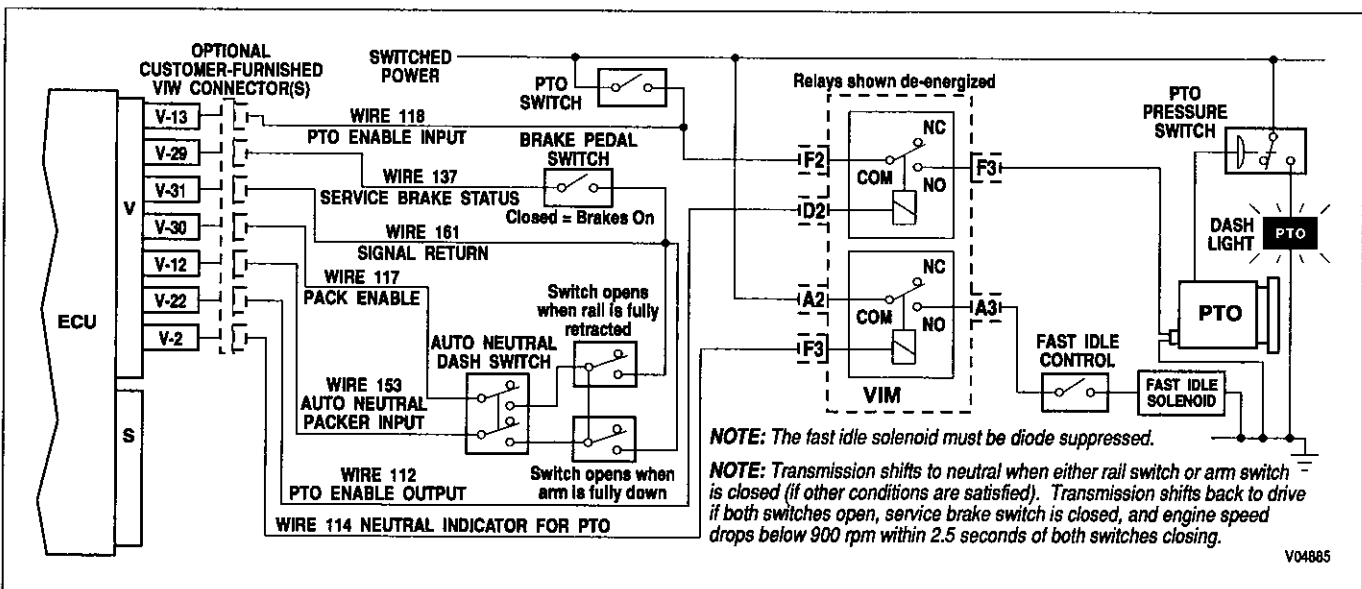

Figure P-32. Automatic Neutral for Refuse Packer and PTO Enable With Service Brake Status (Option 1)

APPENDIX P — INPUT/OUTPUT FUNCTIONS

WARNING!

These schematics show the intended use of the specified controls features which have been validated in the configuration shown. Any miswiring or use of these features which differs from that shown could cause unintended selection of range or other unpredictable operation resulting in damage to equipment or property, personal injury, or loss of life. ALLISON TRANSMISSION IS NOT LIABLE FOR THE CONSEQUENCES ASSOCIATED WITH MISWIRING OR UNINTENDED USE OF THESE FEATURES.

AUTOMATIC NEUTRAL FOR REFUSE PACKER AND PTO ENABLE WITH SERVICE BRAKE STATUS (OPTION 2)

USES: Provides for selection of NEUTRAL and enabling fast idle through activation of a dash mounted switch. Automatically re-engages transmission when switch is opened if service brake is depressed. Only re-engagement of forward is allowed. Reverse is not re-engaged.

VARIABLES TO SPECIFY: Max output rpm to enable Neutral, max engine rpm for PTO engagement, max engine rpm for PTO operation, max output rpm for PTO engagement, max output rpm for PTO operation.

VOCATIONS: Refuse packer, recycling truck

WARNING!

This feature is meant to be used in applications where the vehicle operator remains in the cab. If the operator leaves the vehicle, the park brake must be engaged and Neutral must be selected prior to the operator exiting the cab. In addition, vehicles using this feature must have the following Warning sticker visible in the vehicle cab: "WARNING: Set Park Brake and select Neutral before exiting cab!"

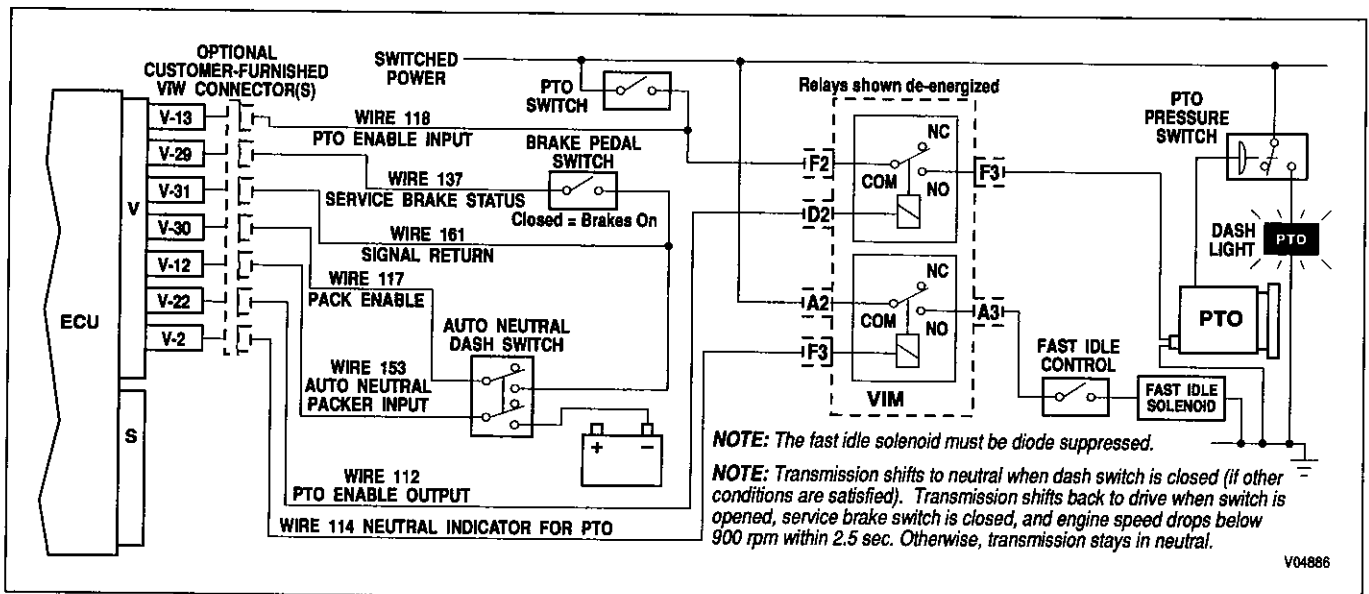

Figure P-33. Automatic Neutral for Refuse Packer and PTO Enable With Service Brake Status (Option 2)

APPENDIX P — INPUT/OUTPUT FUNCTIONS

WARNING!

These schematics show the intended use of the specified controls features which have been validated in the configuration shown. Any miswiring or use of these features which differs from that shown could result in damage to equipment or property, personal injury, or loss of life. ALLISON TRANSMISSION IS NOT LIABLE FOR THE CONSEQUENCES ASSOCIATED WITH MISWIRING OR UNINTENDED USE OF THESE FEATURES.

AUTOMATIC NEUTRAL FOR REFUSE PACKER AND PTO ENABLE WITH SERVICE BRAKE STATUS (OPTION 3)

USES: Provides for automatic selection of NEUTRAL and activation of PTO when park brake is applied. Automatically re-engages transmission when park brake is released (if service brake is depressed). Only re-engagement of forward is permitted. Reverse is not re-engaged.

VARIABLES TO SPECIFY: Max output rpm to enable Neutral, max engine rpm for PTO engagement, max engine rpm for PTO operation, max output rpm for PTO engagement, max output rpm for PTO operation.

VOCATIONS: Refuse packer, recycling truck, emergency equipment.

NOTE: This function is also available with emergency equipment calibration features.

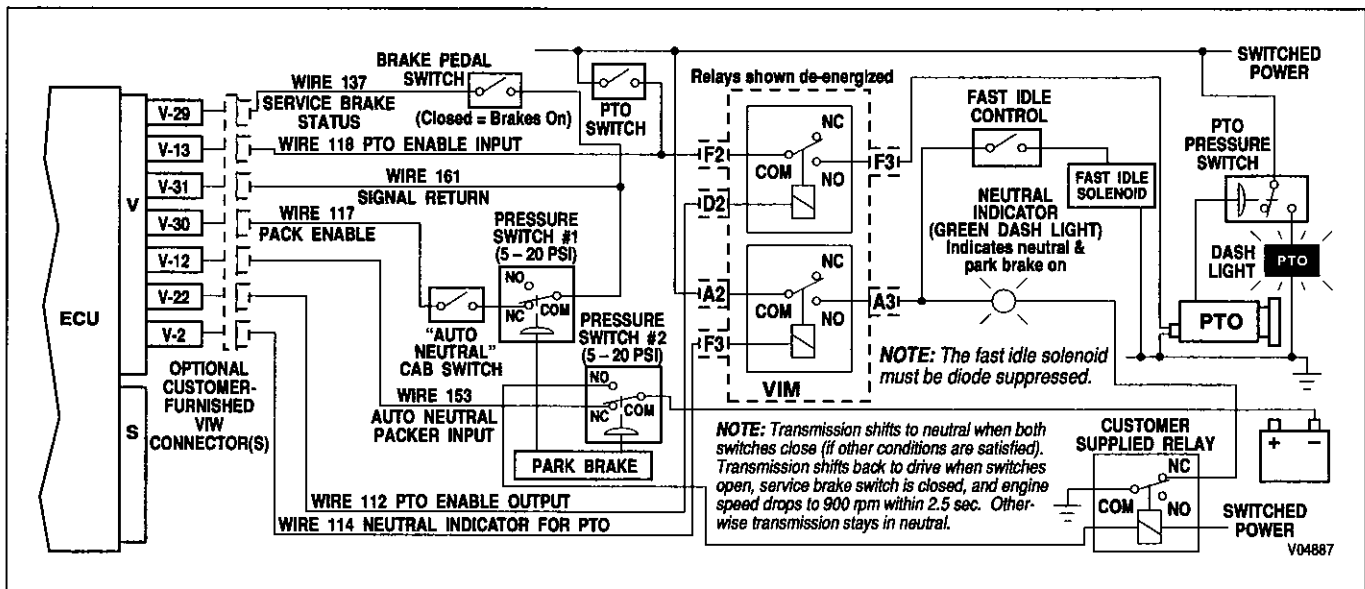

Figure P-34. Automatic Neutral for Refuse Packer and PTO Enable With Service Brake Status (Option 3)

APPENDIX P — INPUT/OUTPUT FUNCTIONS

WARNING!

These schematics show the intended use of the specified controls features which have been validated in the configuration shown. Any miswiring or use of these features which differs from that shown could result in damage to equipment or property, personal injury, or loss of life. ALLISON TRANSMISSION IS NOT LIABLE FOR THE CONSEQUENCES ASSOCIATED WITH MISWIRING OR UNINTENDED USE OF THESE FEATURES.

AUTOMATIC NEUTRAL FOR REFUSE PACKER AND PTO ENABLE WITH SERVICE BRAKE STATUS (OPTION 4)

USES: Provides for automatic selection of NEUTRAL and activation of PTO when work brake is applied. Automatically re-engages transmission when work brake is released (if service brake is depressed). Only re-engagement of forward is permitted. Reverse is not re-engaged.

VARIABLES TO SPECIFY: Max output rpm to enable Neutral, max engine rpm for PTO engagement, max engine rpm for PTO operation, max output rpm for PTO engagement, max output rpm for PTO operation.

VOCATIONS: Refuse packer, recycling truck

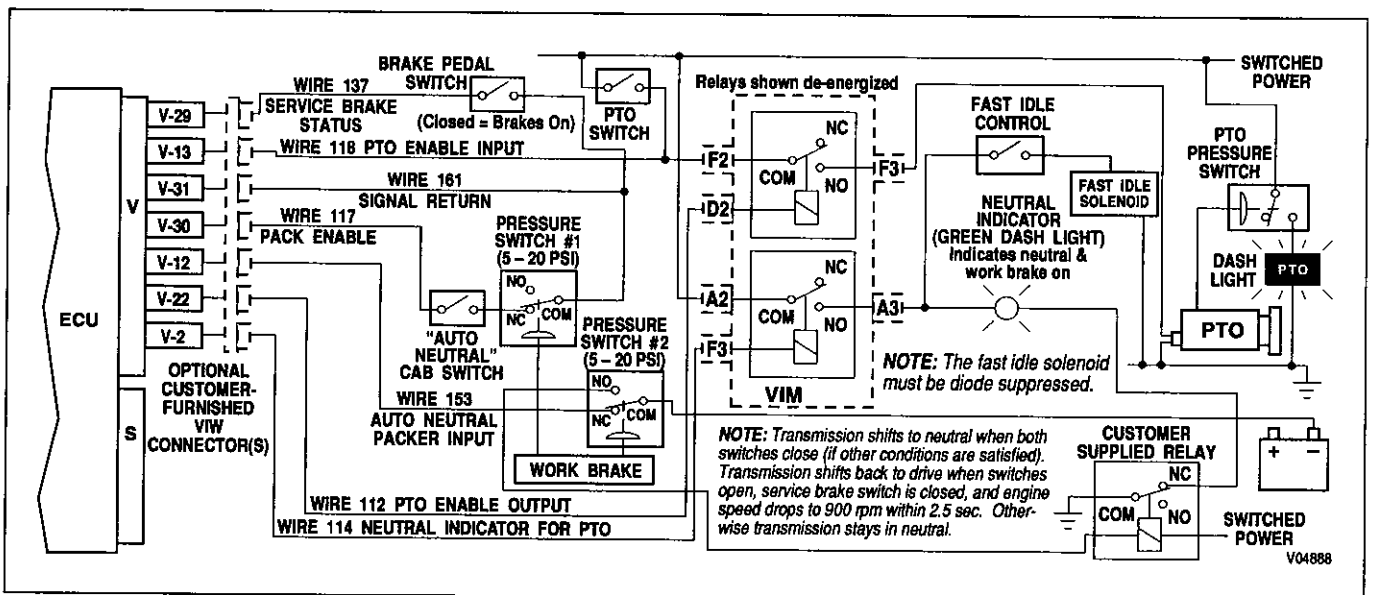

Figure P-35. Automatic Neutral for Refuse Packer and PTO Enable With Service Brake Status (Option 4)

APPENDIX P — INPUT/OUTPUT FUNCTIONS

WARNING!

These schematics show the intended use of the specified controls features which have been validated in the configuration shown. Any miswiring or use of these features which differs from that shown could result in damage to equipment or property, personal injury, or loss of life. ALLISON TRANSMISSION IS NOT LIABLE FOR THE CONSEQUENCES ASSOCIATED WITH MISWIRING OR UNINTENDED USE OF THESE FEATURES.

SHIFT SELECTOR TRANSITION AND SECONDARY SHIFT SCHEDULE

USES: Provides for operator selection of dual shift selectors and shift schedules. Primary mode will always be active when shift selector 1 is selected, and secondary mode will always be active when shift selector 2 is selected.

VARIABLES TO SPECIFY: None

VOCATIONS: Dual-station refuse vehicles, crane carrier

WARNING!

If this function is enabled in the shift calibration, the function **MUST** be integrated into the vehicle wiring. If the function is available in the shift calibration but will not be used in the vehicle, it **MUST** be disabled in the calibration.

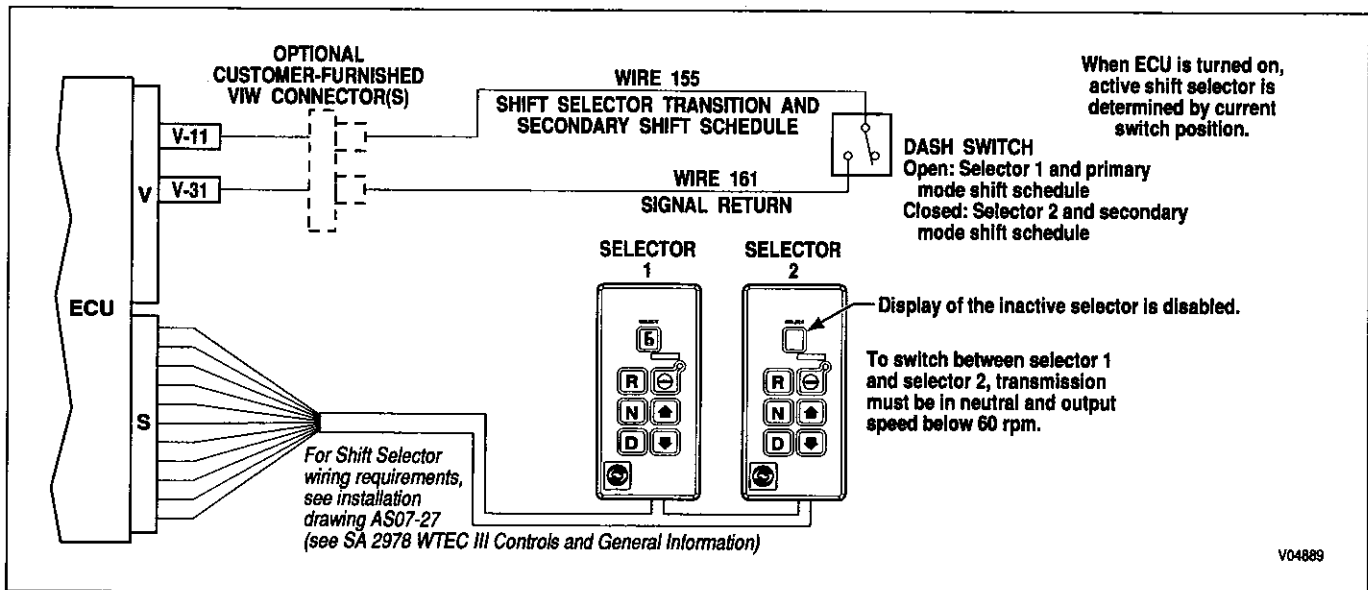

Figure P-36. Shift Selector Transition and Secondary Shift Schedule

APPENDIX P — INPUT/OUTPUT FUNCTIONS

WARNING!

These schematics show the intended use of the specified controls features which have been validated in the configuration shown. Any miswiring or use of these features which differs from that shown could cause unintended selection of range or other unpredictable operation resulting in damage to equipment or property, personal injury, or loss of life. ALLISON TRANSMISSION IS NOT LIABLE FOR THE CONSEQUENCES ASSOCIATED WITH MISWIRING OR UNINTENDED USE OF THESE FEATURES.

REFUSE PACKER STEP SWITCH

USES: Limit operation of transmission to first range and inhibit reverse with presence of personnel on rear of vehicle.

VARIABLES TO SPECIFY: None

VOCATIONS: Refuse

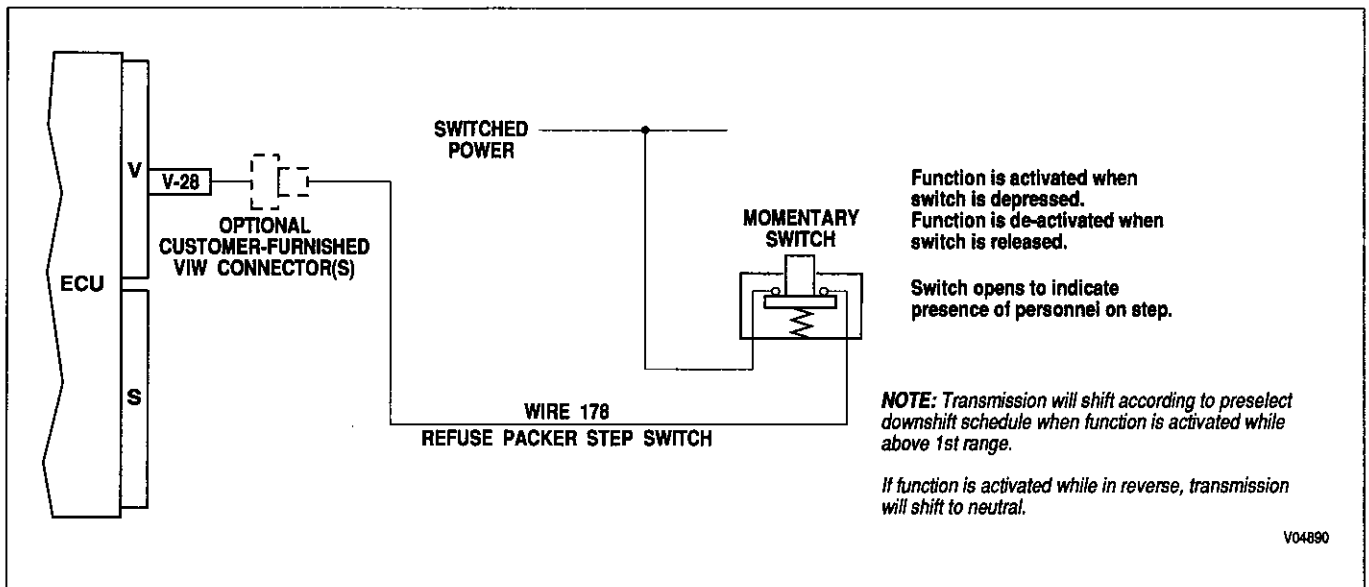

Figure P-37. Refuse Packer Step Switch

APPENDIX P — INPUT/OUTPUT FUNCTIONS

WARNING!

These schematics show the intended use of the specified controls features which have been validated in the configuration shown. Any miswiring or use of these features which differs from that shown could result in damage to equipment or property, personal injury, or loss of life. ALLISON TRANSMISSION IS NOT LIABLE FOR THE CONSEQUENCES ASSOCIATED WITH MISWIRING OR UNINTENDED USE OF THESE FEATURES.

SELECTOR DISPLAY BLANKING

USES: Blanks the digital display and mode on indicator on the lever or pushbutton shift selectors.

VARIABLES TO SPECIFY: None

VOCATIONS: Military wheeled vehicles

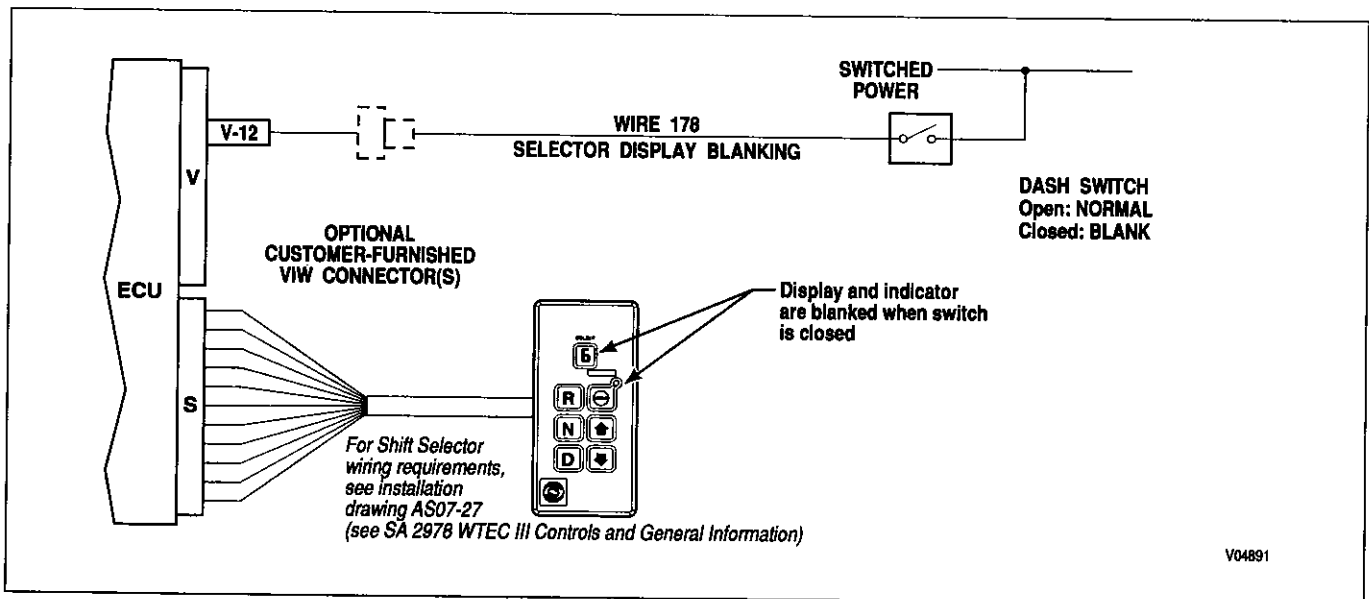

Figure P-38. Selector Display Blanking

APPENDIX P — INPUT/OUTPUT FUNCTIONS

WARNING!

These schematics show the intended use of the specified controls features which have been validated in the configuration shown. Any miswiring or use of these features which differs from that shown could result in damage to equipment or property, personal injury, or loss of life. ALLISON TRANSMISSION IS NOT LIABLE FOR THE CONSEQUENCES ASSOCIATED WITH MISWIRING OR UNINTENDED USE OF THESE FEATURES.

SUMP/RETARDER TEMPERATURE INDICATOR

USES: Turn on dash indicator when transmission sump or retarder-out temperature has exceeded specified limits.

VARIABLES TO SPECIFY: None

VOCATIONS: Various

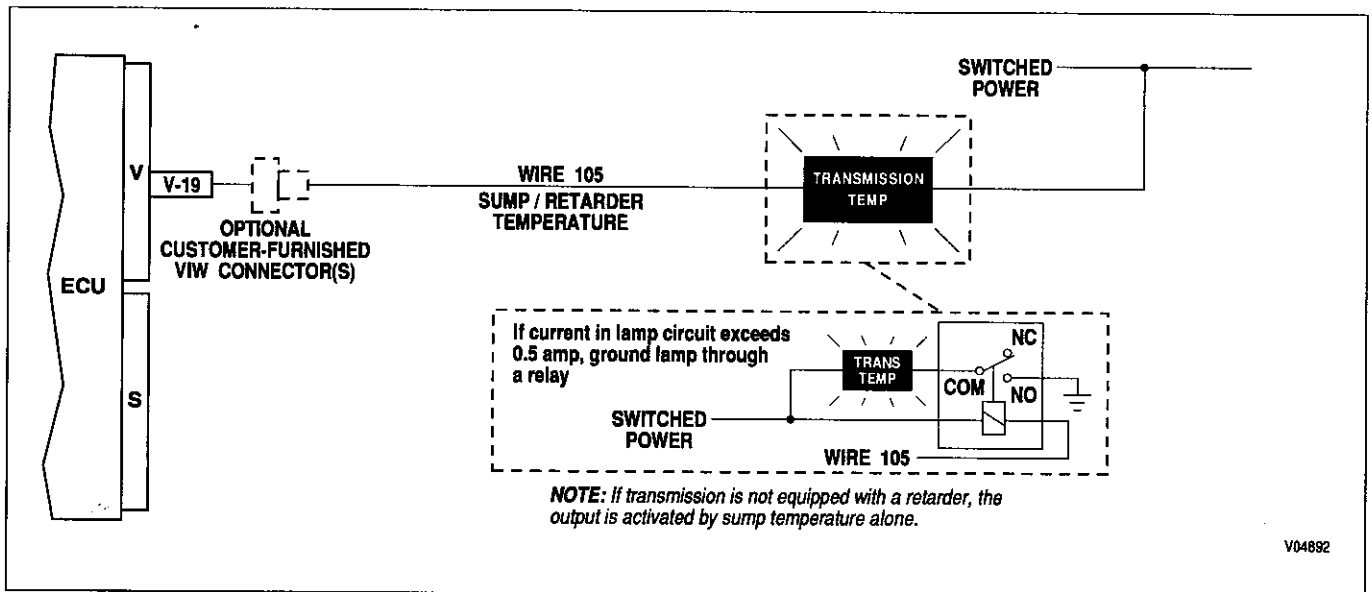

Figure P-39. Sump/Retarder Temperature Indicator

APPENDIX P — INPUT/OUTPUT FUNCTIONS

WARNING!

These schematics show the intended use of the specified controls features which have been validated in the configuration shown. Any miswiring or use of these features which differs from that shown could result in damage to equipment or property, personal injury, or loss of life. ALLISON TRANSMISSION IS NOT LIABLE FOR THE CONSEQUENCES ASSOCIATED WITH MISWIRING OR UNINTENDED USE OF THESE FEATURES.

RANGE INDICATOR

USES: Used with auxiliary vehicle systems to permit operation only in specified transmission range(s).

VARIABLES TO SPECIFY: Range or ranges to be indicated

VOCATIONS: Various

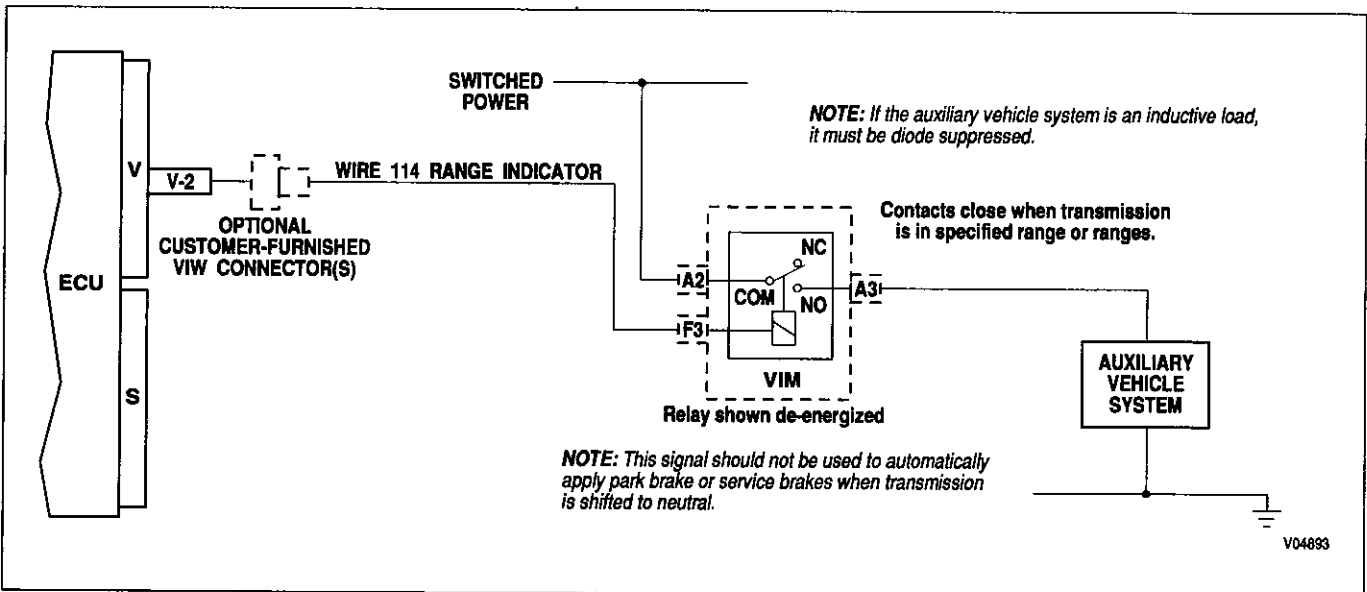

Figure P-40. Range Indicator

APPENDIX P — INPUT/OUTPUT FUNCTIONS

WARNING!

These schematics show the intended use of the specified controls features which have been validated in the configuration shown. Any miswiring or use of these features which differs from that shown could result in damage to equipment or property, personal injury, or loss of life. ALLISON TRANSMISSION IS NOT LIABLE FOR THE CONSEQUENCES ASSOCIATED WITH MISWIRING OR UNINTENDED USE OF THESE FEATURES.

OUTPUT SPEED INDICATOR — A

USES: To signal that the transmission output shaft has exceeded a specified value.

VARIABLES TO SPECIFY: Rpm to turn output ON and to turn output OFF. The ON value must be higher than the OFF value.

VOCATIONS: Various

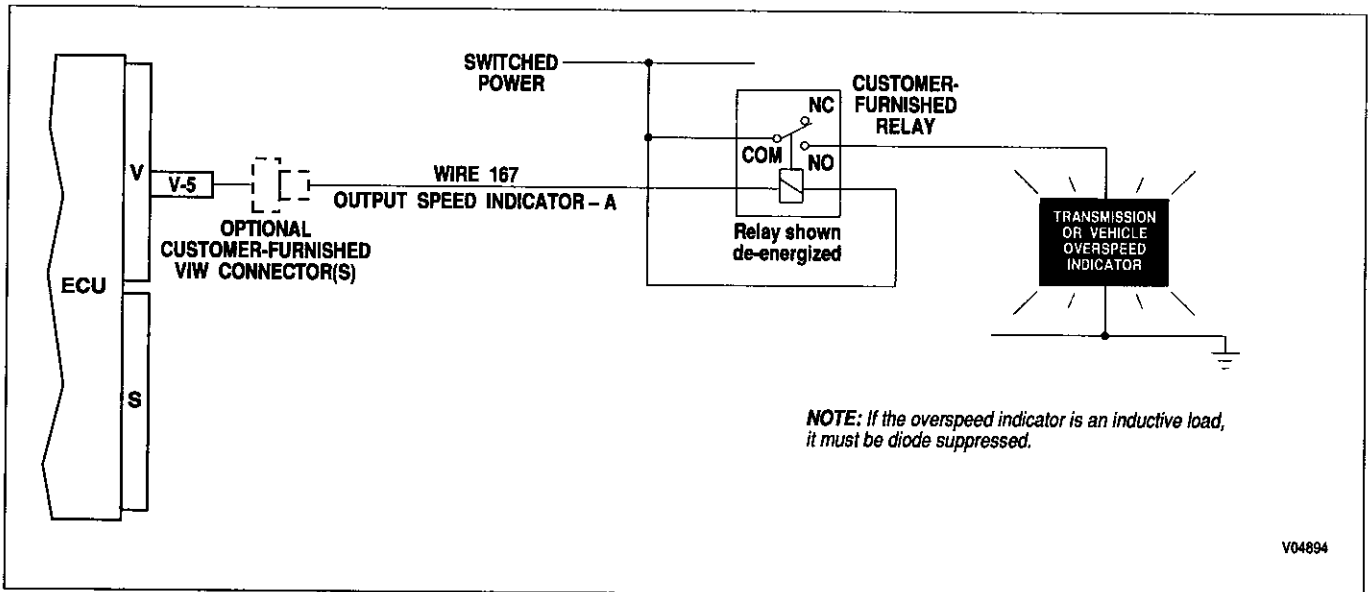

Figure P-41. Output Speed Indicator — A

APPENDIX P — INPUT/OUTPUT FUNCTIONS

WARNING!

These schematics show the intended use of the specified controls features which have been validated in the configuration shown. Any miswiring or use of these features which differs from that shown could result in damage to equipment or property, personal injury, or loss of life. ALLISON TRANSMISSION IS NOT LIABLE FOR THE CONSEQUENCES ASSOCIATED WITH MISWIRING OR UNINTENDED USE OF THESE FEATURES.

OUTPUT SPEED INDICATOR — B

USES: To signal that the transmission output shaft has exceeded a specified value.

VARIABLES TO SPECIFY: Rpm to turn output ON and to turn output OFF. The ON value must be higher than the OFF value.

VOCATIONS: Various

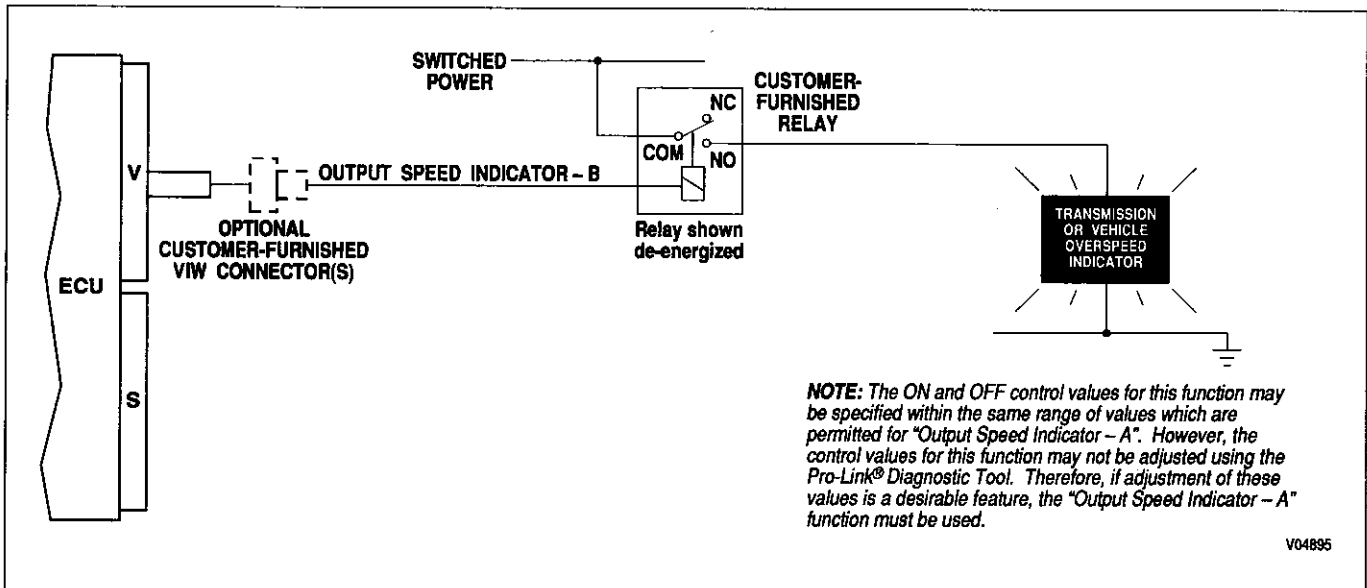

Figure P-42. Output Speed Indicator — B

APPENDIX P — INPUT/OUTPUT FUNCTIONS

WARNING!

These schematics show the intended use of the specified controls features which have been validated in the configuration shown. Any miswiring or use of these features which differs from that shown could result in damage to equipment or property, personal injury, or loss of life. ALLISON TRANSMISSION IS NOT LIABLE FOR THE CONSEQUENCES ASSOCIATED WITH MISWIRING OR UNINTENDED USE OF THESE FEATURES.

PTO OVERSPEED INDICATOR

USES: Turn on dash light when PTO reaches an overspeed condition.

VARIABLES TO SPECIFY: Rpm to turn ON; rpm to turn OFF.

VOCATIONS: Various

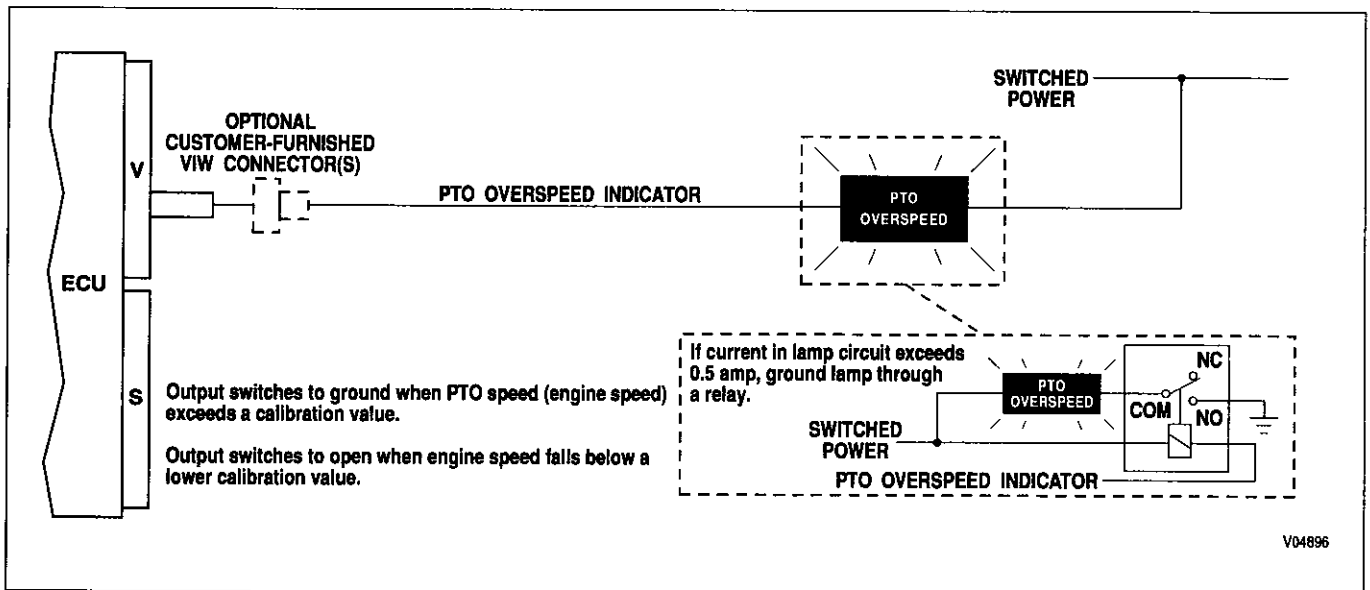

Figure P-43. PTO Overspeed Indicator

APPENDIX P — INPUT/OUTPUT FUNCTIONS

WARNING!

These schematics show the intended use of the specified controls features which have been validated in the configuration shown. Any miswiring or use of these features which differs from that shown could result in damage to equipment or property, personal injury, or loss of life. ALLISON TRANSMISSION IS NOT LIABLE FOR THE CONSEQUENCES ASSOCIATED WITH MISWIRING OR UNINTENDED USE OF THESE FEATURES.

ENGINE OVERSPEED INDICATOR

USES: To turn on dash light when engine reaches an overspeed condition.

VARIABLES TO SPECIFY: Rpm to turn ON; rpm to turn OFF.

VOCATIONS: Various

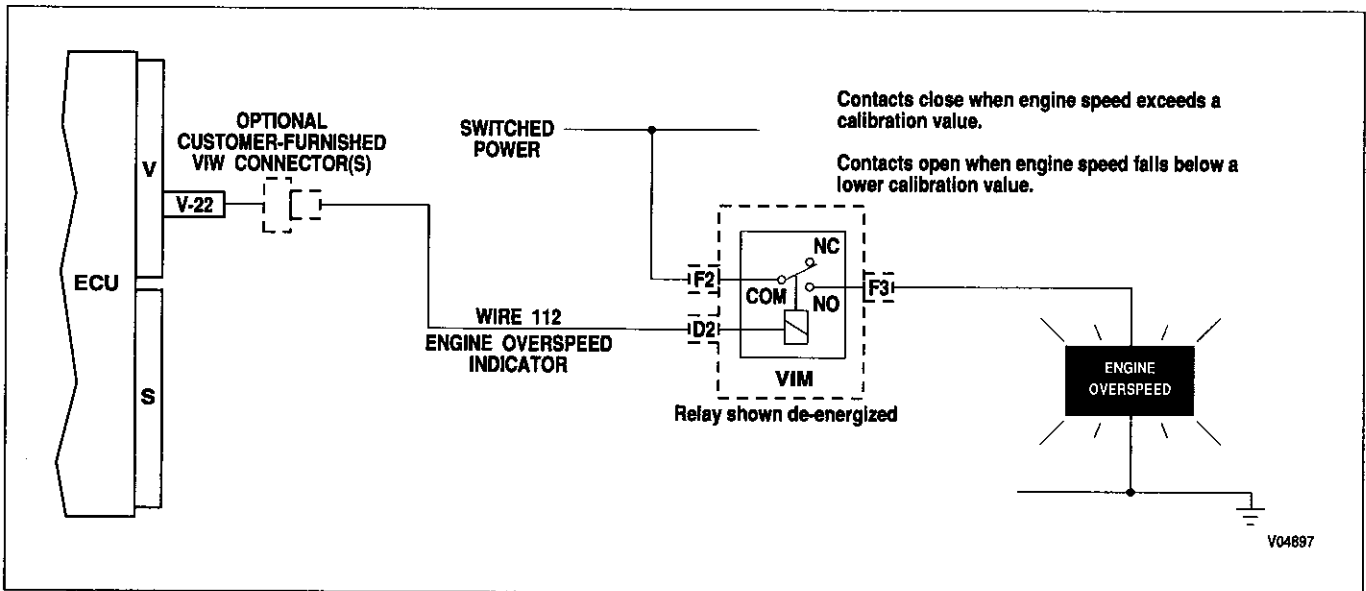

Figure P-44. Engine Overspeed Indicator

APPENDIX P — INPUT/OUTPUT FUNCTIONS

WARNING!

These schematics show the intended use of the specified controls features which have been validated in the configuration shown. Any miswiring or use of these features which differs from that shown could result in damage to equipment or property, personal injury, or loss of life. ALLISON TRANSMISSION IS NOT LIABLE FOR THE CONSEQUENCES ASSOCIATED WITH MISWIRING OR UNINTENDED USE OF THESE FEATURES.

ENGINE OVERSPEED INDICATOR (OPTIONAL)

USES: To turn on dash light when engine reaches an overspeed condition.

VARIABLES TO SPECIFY: Rpm to turn ON; rpm to turn OFF.

VOCATIONS: Various

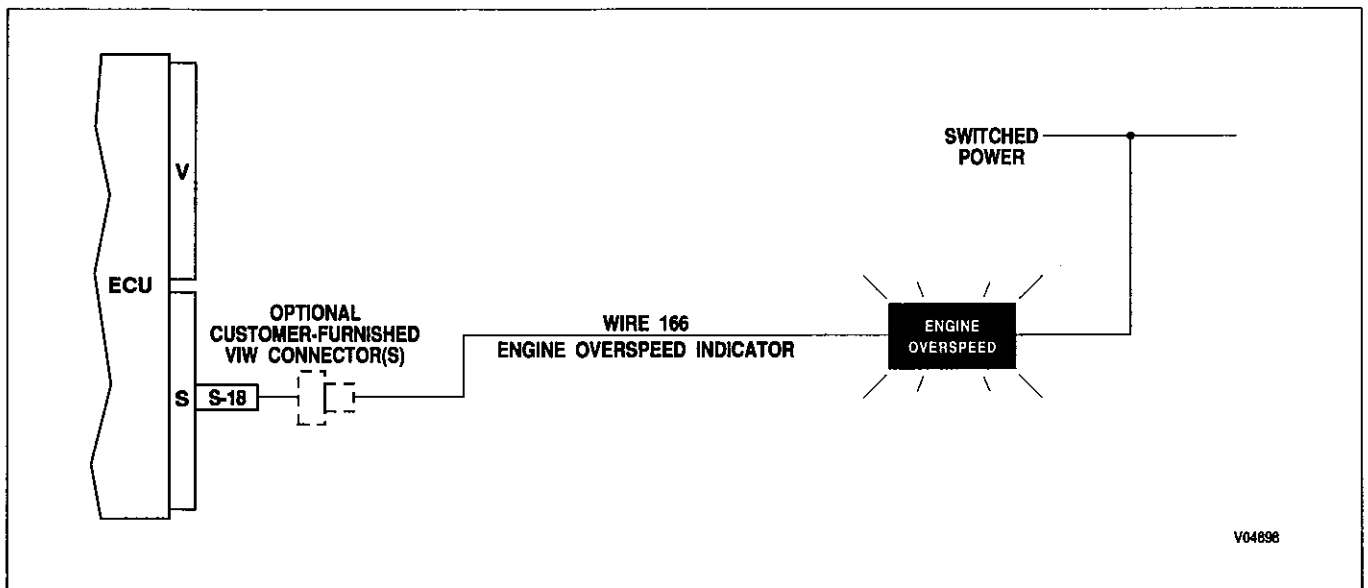

Figure P-45. Engine Overspeed Indicator (Optional)

APPENDIX P — INPUT/OUTPUT FUNCTIONS

WARNING!

These schematics show the intended use of the specified controls features which have been validated in the configuration shown. Any miswiring or use of these features which differs from that shown could result in damage to equipment or property, personal injury, or loss of life. ALLISON TRANSMISSION IS NOT LIABLE FOR THE CONSEQUENCES ASSOCIATED WITH MISWIRING OR UNINTENDED USE OF THESE FEATURES.

LOCKUP INDICATOR

USES: Turn on dash indicator when transmission lockup clutch is engaged. Used to indicate when maximum engine braking is available.

VARIABLES TO SPECIFY: None

VOCATIONS: Various

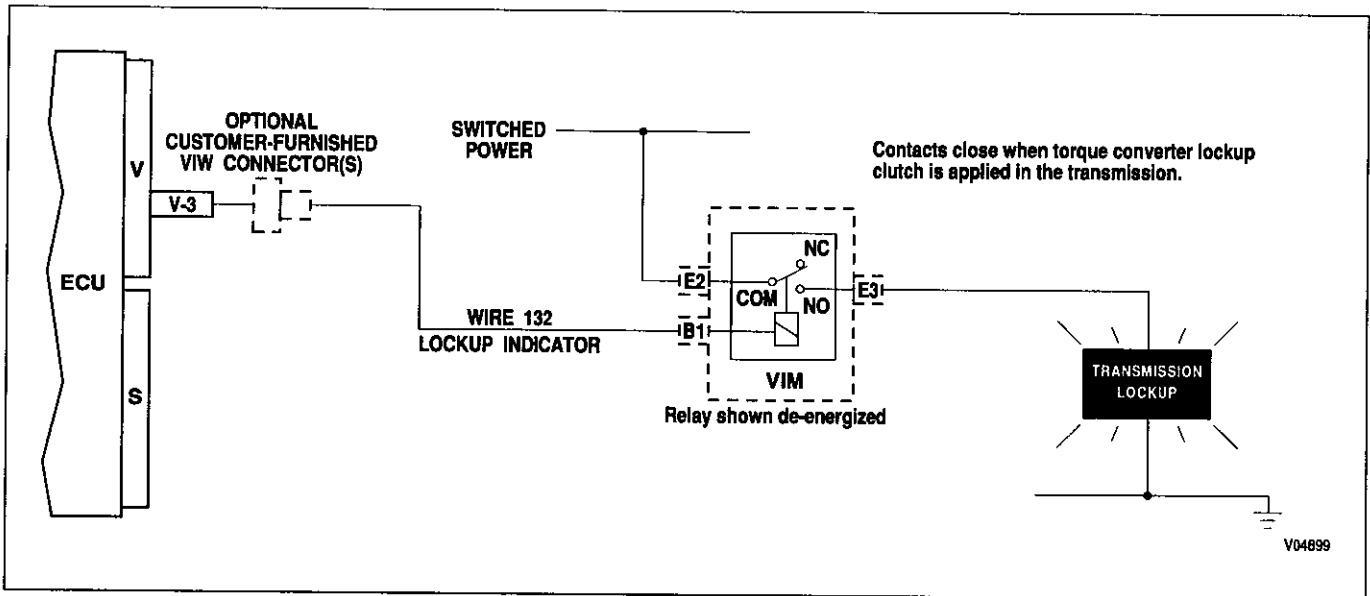

Figure P-46. Lockup Indicator

APPENDIX P — INPUT/OUTPUT FUNCTIONS

WARNING!

These schematics show the intended use of the specified controls features which have been validated in the configuration shown. Any miswiring or use of these features which differs from that shown could result in damage to equipment or property, personal injury, or loss of life. ALLISON TRANSMISSION IS NOT LIABLE FOR THE CONSEQUENCES ASSOCIATED WITH MISWIRING OR UNINTENDED USE OF THESE FEATURES.

SECONDARY MODE INDICATOR

USES: To indicate that Secondary Mode is active.

VARIABLES TO SPECIFY: None

VOCATIONS: Various

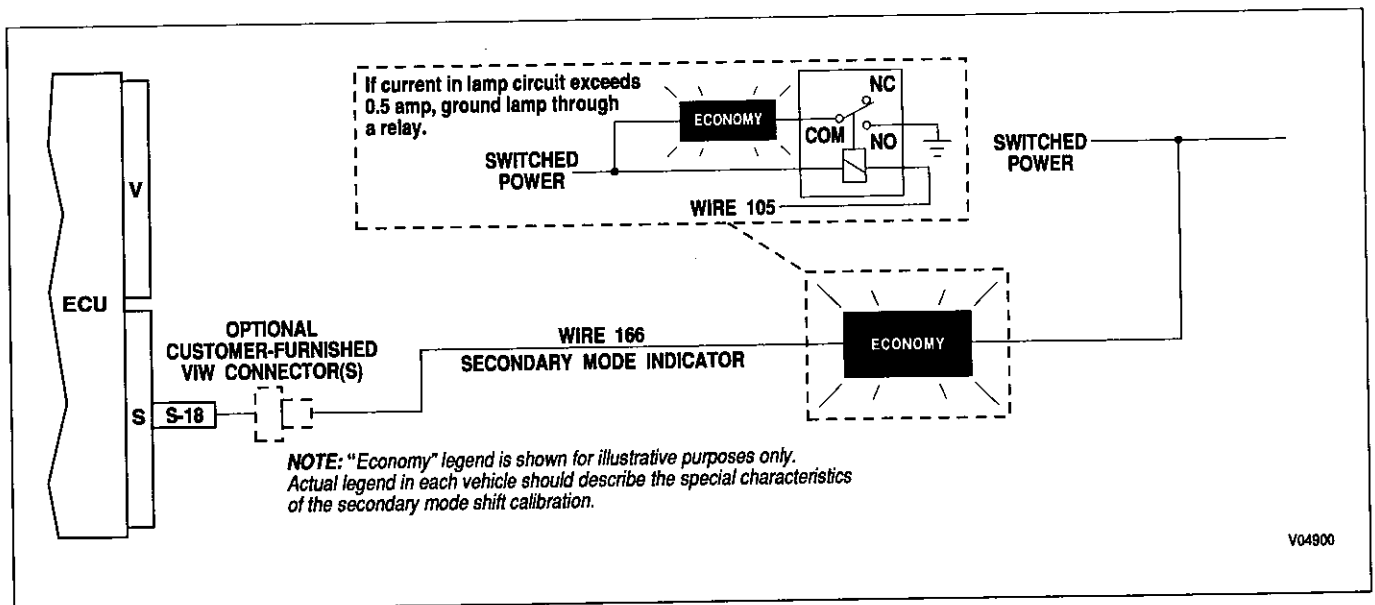

Figure P-47. Secondary Mode Indicator

APPENDIX P — INPUT/OUTPUT FUNCTIONS

WARNING!

These schematics show the intended use of the specified controls features which have been validated in the configuration shown. Any miswiring or use of these features which differs from that shown could result in damage to equipment or property, personal injury, or loss of life. **ALLISON TRANSMISSION IS NOT LIABLE FOR THE CONSEQUENCES ASSOCIATED WITH MISWIRING OR UNINTENDED USE OF THESE FEATURES.**

RETARDER INDICATOR

USES: Signals that the retarder is active. Typically used to turn on the vehicle brake lights when the retarder is in use.

VARIABLES TO SPECIFY: None

VOCATIONS: Various

This function is used in conjunction with Input Function, Retarder Enable. Refer to schematic for Retarder Enable Input Function, noting the use of wire 125.

APPENDIX P — INPUT/OUTPUT FUNCTIONS

WARNING!

These schematics show the intended use of the specified controls features which have been validated in the configuration shown. Any miswiring or use of these features which differs from that shown could cause unscheduled operation of the PTO or other unpredictable operation resulting in damage to equipment or property, personal injury, or loss of life. ALLISON TRANSMISSION IS NOT LIABLE FOR THE CONSEQUENCES ASSOCIATED WITH MISWIRING OR UNINTENDED USE OF THESE FEATURES.

NEUTRAL INDICATOR FOR PTO AND PTO ENABLE

USES: Provides for fast idle operation in neutral, “pack-on-the-fly”, and PTO engagement with overspeed protection.

VARIABLES TO SPECIFY: Max engine rpm for PTO engagement, max engine rpm for PTO operation, max output rpm for PTO engagement, max output rpm for PTO operation.

VOCATIONS: Refuse packer, recycling truck.

SYSTEM OPERATION:

Operator selects NEUTRAL to enable fast idle.

Transmission shifts to neutral if throttle and output speed are low.

When DRIVE is re-selected, fast idle is interrupted and transmission shifts to drive if engine speed drops below 900 rpm within approximately two seconds.

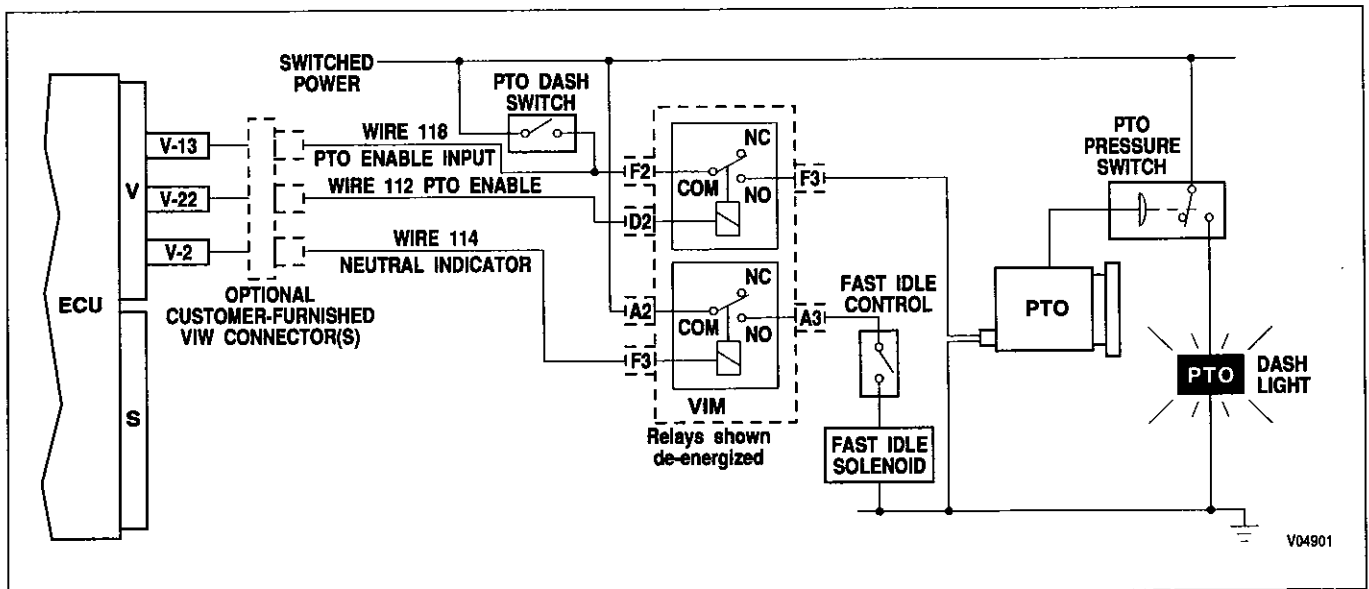

Figure P-48. Neutral Indicator for PTO and PTO Enable

APPENDIX P — INPUT/OUTPUT FUNCTIONS

NOTES

APPENDIX Q — TRANSID 2 THERMISTOR TROUBLESHOOTING INFORMATION

Resistance Vs. Temperature Characteristics

Graph Q-1 is a graph of the temperature indicated by the resistance measured in the new and the old thermistors. The new thermistors have a negative temperature coefficient which means the indicated temperature increases as the measured resistance decreases within a range of about 200,000 Ohms (Ω) down to about 50 Ohms (Ω) for the sump thermistor and about 400,000 Ohms (Ω) down to about 60 Ohms (Ω) for the retarder thermistor. The old thermistors (sump and retarder) have a positive temperature coefficient which means that the indicated temperature increases as the measured resistance increases within a range from about 500 Ohms (Ω) up to about 2500 Ohms (Ω). The two thermistors require different ECU calibrations. Mismatches between the ECU and the transmission can cause performance problems or diagnostic codes to be set. This is why the TID 2 transmission is not compatible with the WTEC II ECU (V6E, V7, or V7A) or with the WTEC III ECU (V8). The proper shift and temperature characteristics for both the TID 1 and the TID 2 transmission are calibrated in the V8A WTEC III ECU and the proper calibration will be activated by the ECU according to the TransID wire (wire 195) connection point in the internal harness.

RESISTANCE-TEMPERATURE CHARACTERISTIC CHART

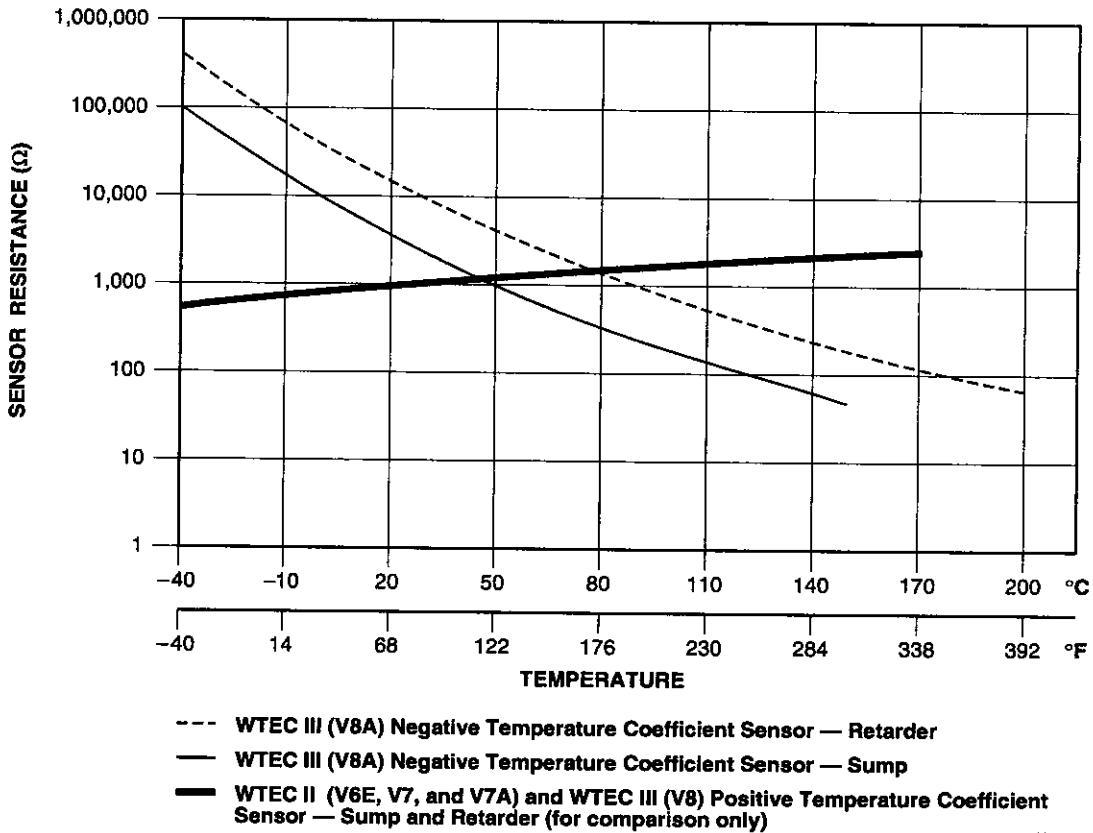

V04711

Graph Q-1.

NOTE: Look carefully at the graph. The scale for the resistance {on the left side} is not constant {linear}. It is logarithmic which means it can display a great range of values within a small space. Each section of the graph is ten units, but the units vary from 1 to 100,000 Ohms. The range of resistance for the old thermistor is very small when compared with that of the new thermistors.

The following table shows the range of resistance values that correspond to either retarder or sump fluid temperature shown in one degree increments over the operating range of the thermistors.

APPENDIX Q — TRANSID 2 THERMISTOR TROUBLESHOOTING INFORMATION

TRANSID 2 THERMISTORS — RESISTANCE (OHMS) VS. TEMPERATURE

Retarder Thermistor					Sump Thermistor				
Degree C	Degree F	Lo Ohms	Nom Ohms	Hi Ohms	Degree C	Degree F	Lo Ohms	Nom Ohms	Hi Ohms
					-50	-58	202642	182288	226183
					-49	-56.2	188561	169859	210206
					-48	-54.4	175549	158357	195459
					-47	-52.6	163519	147708	181840
					-46	-50.8	152390	137844	169255
					-45	-49	142089	128702	157621
					-44	-47.2	132550	120224	146860
					-43	-45.4	123711	112359	136900
					-42	-43.6	115517	105057	127678
					-41	-41.8	107917	98276	119134
-40	-40	352399	402392	452385	-40	-40	100865	95956	107181
-39	-38.2	329878	376270	422662	-39	-38.2	94317	89769	100181
-38	-36.4	308936	352005	395074	-38	-36.4	88235	84019	93681
-37	-34.6	289453	329454	369456	-37	-34.6	82582	78674	87642
-36	-32.8	271318	308486	345655	-36	-32.8	77326	73701	82030
-35	-31	254431	288981	323531	-35	-31	72437	69073	76811
-34	-29.2	238698	270827	302956	-34	-29.2	67886	64764	71956
-33	-27.4	224033	253923	283814	-33	-27.4	63649	60749	67497
-32	-25.6	210358	238177	265995	-32	-25.6	59702	57008	63228
-31	-23.8	197600	223501	249402	-31	-23.8	56024	53520	59308
-30	-22	185693	209817	233941	-30	-22	52594	50266	55654
-29	-20.2	174574	197053	219531	-29	-20.2	49394	47229	52247
-28	-18.4	164188	185140	206093	-28	-18.4	46408	44394	49069
-27	-16.6	154480	174018	193556	-27	-16.6	43620	41746	46102
-26	-14.8	145404	163630	181856	-26	-14.8	41016	39271	43332
-25	-13	136915	153923	170930	-25	-13	38583	36958	40745
-24	-11.2	128971	144848	160724	-24	-11.2	36308	34794	38328
-23	-9.4	121534.6	136360.5	151188	-23	-9.4	34181	32770	36088
-22	-7.6	114569.9	128419.6	142269.4	-22	-7.6	32190	30875	33954
-21	-5.8	108044.7	120987	133929.3	-21	-5.8	30327	29101	31976
-20	-4	101928.7	114027.2	126125.7	-20	-4	28582	27439	30125
-19	-2.2	96194	107507.5	118821	-19	-2.2	26948	25881	28391
-18	-0.4	90814.8	101397.8	111980.7	-18	-0.4	25417	24420	26767
-17	1.4	85767	95669.8	105572.7	-17	1.4	23981	23051	25245
-16	3.2	81028.5	90297.8	99567.2	-16	3.2	22634	21766	23818
-15	5	76578.5	85257.7	93937	-15	5	21371	20660	22480
-14	6.8	72397.9	80527.1	88656.4	-14	6.8	20185	19427	21225
-13	8.6	68469	76085.4	83701.9	-13	8.6	19072	18363	20046
-12	10.4	64775.3	71913.4	79051.6	-12	10.4	18026	17363	18940

APPENDIX Q — TRANSID 2 THERMISTOR TROUBLESHOOTING INFORMATION

TRANSID 2 THERMISTORS — RESISTANCE (OHMS) VS. TEMPERATURE (cont'd)

Retarder Thermistor					Sump Thermistor				
Degree C	Degree F	Lo Ohms	Nom Ohms	Hi Ohms	Degree C	Degree F	Lo Ohms	Nom Ohms	Hi Ohms
-11	12.2	61301.3	67993.3	74685.3	-11	12.2	17043	16424	17900
-10	14	58033	64308.5	70584	-10	14	16120	15540	16924
-9	15.8	54956.9	60843.6	66730.3	-9	15.8	15251	14709	16006
-8	17.6	52060.8	57584.4	63108	-8	17.6	14434	13927	15143
-7	19.4	49333.13	54517.51	59701.9	-7	19.4	13666	13190	14331
-6	21.2	46763.28	51630.64	56498	-6	21.2	12942	12497	13567
-5	23	44341.27	48912.25	53483.24	-5	23	12261	11844	12848
-4	24.8	42057.81	46351.65	50645.49	-4	24.8	11619	11228	12171
-3	26.6	39904.26	43938.84	47973.42	-3	26.6	11014	10648	11533
-2	28.4	37872.55	41664.54	45456.53	-2	28.4	10444	10101	10932
-1	30.2	35955	39520	43085	-1	30.2	9906	9585	10365
0	32	34145.1	37497.4	40850	0	32	9399	9098	9831
1	33.8	32430	35590	38750	1	33.8	8921	8638	9329
2	35.6	30810	33790	36770	2	35.6	8470	8203	8854
3	37.4	29282	32092	34903	3	37.4	8044	7793	8407
4	39.2	27838	30490	33142	4	39.2	7643	7406	7985
5	41	26474	28976	31479	5	41	7263	7041	7587
6	42.8	25184	27547	29910	6	42.8	6905	6696	7211
7	44.6	23965	26197	28428	7	44.6	6567	6369	6855
8	46.4	22813	24920	27028	8	46.4	6247	6061	6519
9	48.2	21722	23713	25704	9	48.2	5944	5769	6202
10	50	20690	22572	24454	10	50	5658	5493	5902
11	51.8	19712	21492	23271	11	51.8	5387	5231	5618
12	53.6	18787	20469	22152	12	53.6	5131	4984	5349
13	55.4	17910	19502	21093	13	55.4	4888	4750	5095
14	57.2	17079	18585	20091	14	57.2	4659	4528	4854
15	59	16292	17717	19141	15	59	4441	4318	4626
16	60.8	15545	16894	18242	16	60.8	4235	4118	4410
17	62.6	14836.8	16113.8	17391	17	62.6	4039	3929	4205
18	64.4	14164.8	15374.1	16583.5	18	64.4	3854	3750	4011
19	66.2	13527	14672.6	15818.2	19	66.2	3678	3580	3827
20	68	12921.4	14006.9	15092.4	20	68	3511	3418	3653
21	69.8	12346.4	13375.1	14403.8	21	69.8	3353	3265	3487
22	71.6	11800.1	12775.3	13750.5	22	71.6	3202	3120	3330
23	73.4	11281	12205.7	13130.3	23	73.4	3060	2981	3180
24	75.2	10787.6	11664.6	12541	24	75.2	2924	2850	3039
25	77	10318.5	11150.4	11982.3	25	77	2795	2725	2904
26	78.8	9872.4	10661.7	11451	26	78.8	2673	2606	2776
27	80.6	9448	10197.1	10946.1	27	80.6	2556	2493	2655

APPENDIX Q — TRANSID 2 THERMISTOR TROUBLESHOOTING INFORMATION

TRANSID 2 THERMISTORS — RESISTANCE (OHMS) VS. TEMPERATURE (cont'd)

Retarder Thermistor					Sump Thermistor				
Degree C	Degree F	Lo Ohms	Nom Ohms	Hi Ohms	Degree C	Degree F	Lo Ohms	Nom Ohms	Hi Ohms
28	82.4	9755.2	9755.2	10466.2	28	82.4	2445	2385	2540
29	84.2	8659.8	9334.9	10009.9	29	84.2	2340	2282	2430
30	86	8293.8	8934.9	9575.9	30	86	2240	2185	2326
31	87.8	7945.3	8554.2	9163.1	31	87.8	2144	2092	2227
32	89.6	7613.3	8191.7	8770.2	32	89.6	2053	2003	2132
33	91.4	7296.91	7846.57	8396.2	33	91.4	1967	1919	2043
34	93.2	6995.38	7517.77	8040.17	34	93.2	1884	1839	1957
35	95	6707.92	7204.5	7701.07	35	95	1806	1763	1875
36	96.8	6433.8	6905.92	7378.04	36	96.8	1731	1690	1797
37	98.6	6172.32	6621.29	7070.25	37	98.6	1660	1620	1723
38	100.4	5922.86	6349.87	6776.89	38	100.4	1592	1554	1653
39	102.2	5685	6091	6497	39	102.2	1527	1491	1585
40	104	5457.5	5844	6231	40	104	1465	1430	1521
41	105.8	5241	5608	5976	41	105.8	1406	1373	1459
42	107.6	5033	5383	5733	42	107.6	1349	1318	1401
43	109.4	4835	5169	5502	43	109.4	1296	1265	1345
44	111.2	4646	4963	5281	44	111.2	1244	1215	1291
45	113	4465	4768	5070	45	113	1195	1167	1240
46	114.8	4293	4580	4868	46	114.8	1148	1122	1192
47	116.6	4127	4402	4676	47	116.6	1103	1078	1145
48	118.4	3969	4231	4492	48	118.4	1060	1036	1100
49	120.2	3818	4067	4316	49	120.2	1019	996.3	1058
50	122	3673	3911	4148	50	122	980.3	958.1	1017
51	123.8	3535	3761	3988	51	123.8	942.9	921.6	978.4
52	125.6	3403	3619	3835	52	125.6	907.1	886.7	941.4
53	127.4	3276	3482	3688	53	127.4	872.9	853.3	905.9
54	129.2	3155	3352	3548	54	129.2	840.1	821.4	871.9
55	131	3039	3227	3414	55	131	808.8	790.8	839.4
56	132.8	2928	3107	3286	56	132.8	778.8	761.5	808.3
57	134.6	2821	2992	3163	57	134.6	750	733.5	778.5
58	136.4	2718.9	2882.4	3046	58	136.4	722.5	706.6	750
59	138.2	2621.1	2777.3	2933.5	59	138.2	696.2	680.9	722.7
60	140	2527.2	2676.5	2825.7	60	140	670.9	656.2	696.5
61	141.8	2437.3	2579.9	2722.5	61	141.8	646.7	632.6	671.4
62	143.6	2351	2487.3	2623.6	62	143.6	623.5	609.9	647.3
63	145.4	2268.2	2398.5	2528.8	63	145.4	601.2	588.2	624.2
64	147.2	2188.8	2313.4	2438	64	147.2	579.9	567.4	602.1
65	149	2112.5	2231.7	2350.8	65	149	559.4	547.4	580.8
66	150.8	2039.3	2153.3	2267.3	66	150.8	539.8	528.2	560.5

APPENDIX Q — TRANSID 2 THERMISTOR TROUBLESHOOTING INFORMATION

TRANSID 2 THERMISTORS — RESISTANCE (OHMS) VS. TEMPERATURE (cont'd)

Retarder Thermistor					Sump Thermistor				
Degree C	Degree F	Lo Ohms	Nom Ohms	Hi Ohms	Degree C	Degree F	Lo Ohms	Nom Ohms	Hi Ohms
67	152.6	1969.1	2078.1	2187.1	67	152.6	520.9	509.8	540.9
68	154.4	1901.6	2005.9	2110.2	68	154.4	502.8	492.1	522.2
69	156.2	1836.8	1936.6	2036.4	69	156.2	485.4	475.2	504.1
70	158	1774.5	1870	1965.5	70	158	468.7	458.9	486.8
71	159.8	1714.6	1806.1	1897.5	71	159.8	452.7	443.2	470.2
72	161.6	1657.1	1744.6	1832.2	72	161.6	437.3	428.2	454.2
73	163.4	1601.8	1685.6	1769.4	73	163.4	422.5	413.7	438.9
74	165.2	1548.65	1628.89	1709.1	74	165.2	408.3	399.8	424.1
75	167	1497.52	1574.36	1651.21	75	167	394.6	386.5	410
76	168.8	1448.33	1521.94	1595.54	76	168.8	381.5	373.6	396.3
77	170.6	1401.01	1471.52	1542.03	77	170.6	368.9	361.3	383.2
78	172.4	1355.47	1423.03	1490.58	78	172.4	356.7	349.4	370.6
79	174.2	1311.65	1376.38	1441.11	79	174.2	345	338	358.5
80	176	1269	1331	1394	80	176	333.8	327	346.8
81	177.8	1228.3	1288.3	1348	81	177.8	322.9	316.4	335.6
82	179.6	1190	1247	1304	82	179.6	312.5	306.2	324.7
83	181.4	1152	1207	1261	83	181.4	302.5	296.4	314.3
84	183.2	1116	1168	1220	84	183.2	292.8	288.9	304.3
85	185	1081	1131	1181	85	185	283.5	277.8	294.6
86	186.8	1047	1095	1143	86	186.8	274.5	269	285.4
87	188.6	1015	1061	1107	87	188.6	265.9	260.5	276.5
88	190.4	983	1028	1072	88	190.4	257.6	253.3	268
89	192.2	953	996	1038	89	192.2	249.5	244.3	259.7
90	194	924	965	1005	90	194	241.8	236.7	251.7
91	195.8	896	935	974	91	195.8	234.4	229.4	244
92	197.6	869	906	944	92	197.6	227.2	222.3	236.6
93	199.4	843	879	915	93	199.4	220.2	215.5	229.5
94	201.2	817	852	886	94	201.2	213.5	208.9	222.6
95	203	793	826	859	95	203	207.1	202.5	215.9
96	204.8	769	801	833	96	204.8	200.9	196.4	209.5
97	206.6	747	777	808	97	206.6	194.8	190.5	203.3
98	208.4	725	754	784	98	208.4	189	184.8	197.3
99	210.2	703.6	731.8	760	99	210.2	183.4	179.2	191.5
100	212	683.2	710.2	737.3	100	212	178	173.9	185.9
101	213.8	663.4	689.4	715.3	101	213.8	172.8	168.8	180.5
102	215.6	644.4	669.3	694.1	102	215.6	167.8	163.8	175.3
103	217.4	626	649.8	673.7	103	217.4	162.9	159	170.3
104	219.2	608.2	631.1	653.9	104	219.2	158.2	154.4	165.4
105	221	591	612.9	634.9	105	221	159.6	149.9	160.7

APPENDIX Q — TRANSID 2 THERMISTOR TROUBLESHOOTING INFORMATION

TRANSID 2 THERMISTORS — RESISTANCE (OHMS) VS. TEMPERATURE (cont'd)

Retarder Thermistor					Sump Thermistor				
Degree C	Degree F	Lo Ohms	Nom Ohms	Hi Ohms	Degree C	Degree F	Lo Ohms	Nom Ohms	Hi Ohms
106	222.8	574.3	595.4	616.5	106	222.8	149.2	145.6	156.2
107	224.6	558.2	578.4	598.7	107	224.6	145	141.4	151.8
108	226.4	542.6	562.1	581.5	108	226.4	140.9	137.4	147.5
109	228.2	527.6	546.2	564.9	109	228.2	136.9	133.5	143.4
110	230	513	530.9	548.8	110	230	133.1	129.7	139.4
111	231.8	498.8	516.1	533.3	111	231.8	129.4	126.1	135.6
112	233.6	485.2	501.8	518.3	112	233.6	125.8	122.6	131.9
113	235.4	471.9	487.9	503.9	113	235.4	122.3	119.2	128.2
114	237.2	459.1	474.5	489.8	114	237.2	118.9	115.9	124.8
115	239	446.73	461.51	476.3	115	239	115.7	112.7	121.4
116	240.8	434.72	448.95	463.18	116	240.8	112.5	109.6	118.1
117	242.6	423.08	436.79	450.5	117	242.6	109.5	106.6	114.9
118	244.4	411.8	425.02	438.23	118	244.4	106.5	103.7	111.9
119	246.2	400.88	413.61	426.35	119	246.2	103.7	100.91	108.9
120	248	390.29	402.57	414.86	120	248	100.9	98.2	106
121	249.8	380	392	404	121	249.8	98.23	95.58	103.2
122	251.6	370.1	381.5	393	122	251.6	95.63	93.04	100.5
123	253.4	360	371	383	123	253.4	93.12	90.58	97.9
124	255.2	351	362	372	124	255.2	90.68	88.2	95.36
125	257	342	352	363	125	257	88.32	85.89	92.9
126	258.8	333	343	353	126	258.8	86.03	83.65	90.51
127	260.6	325	334	344	127	260.6	83.8	81.49	88.19
128	262.4	316	326	335	128	262.4	81.65	79.38	85.95
129	264.2	308	317	326	129	264.2	79.56	77.35	83.77
130	266	301	309	318	130	266	77.54	75.37	81.65
131	267.8	293	302	310	131	267.8	75.58	73.46	79.6
132	269.6	286	294	302	132	269.6	73.67	71.6	77.61
133	271.4	279	287	294	133	271.4	71.82	69.8	75.68
134	273.2	272	279	287	134	273.2	70.03	68.05	73.8
135	275	265	272	280	135	275	68.29	66.35	71.98
136	276.8	258	266	273	136	276.8	66.6	64.7	70.21
137	278.6	252	259	266	137	278.6	64.96	63.11	68.5
138	280.4	246	253	260	138	280.4	63.37	61.56	66.83
139	282.2	240	247	253	139	282.2	61.82	60.05	65.21
140	284	234.2	240.6	247	140	284	60.32	58.59	63.64
141	285.8	228.6	234.8	241.1	141	285.8	58.86	57.17	62.11
142	287.6	223.1	229.2	235.2	142	287.6	57.45	55.79	60.63
143	289.4	217.8	223.7	229.6	143	289.4	56.07	54.45	59.18
144	291.2	212.6	218.4	224.1	144	291.2	54.73	53.15	57.78

APPENDIX Q — TRANSID 2 THERMISTOR TROUBLESHOOTING INFORMATION

TRANSID 2 THERMISTORS — RESISTANCE (OHMS) VS. TEMPERATURE (cont'd)

Retarder Thermistor					Sump Thermistor				
Degree C	Degree F	Lo Ohms	Nom Ohms	Hi Ohms	Degree C	Degree F	Lo Ohms	Nom Ohms	Hi Ohms
145	293	207.6	213.2	218.8	145	293	53.43	51.89	56.42
146	294.8	202.7	208.1	213.6	146	294.8	52.17	50.66	55.09
147	296.6	197.9	203.2	208.5	147	296.6	50.94	49.47	53.81
148	298.4	193.3	198.5	203.7	148	298.4	49.75	48.31	52.55
149	300.2	188.8	193.9	198.9	149	300.2	48.59	47.18	51.34
150	302	184.4	189.4	194.3	150	302	47.46	46.09	50.15
151	303.8	180.2	185	189.8					
152	305.6	176	180.7	185.4					
153	307.4	172	176.6	181.2					
154	309.2	168.1	172.6	177.1					
155	311	164.3	168.6	173					
156	312.8	160.54	164.84	169.1					
157	314.6	156.93	161.13	165.33					
158	316.4	153.42	157.53	161.63					
159	318.2	150.01	154.01	158.02					
160	320	146.68	150.6	154.51					
161	321.8	143.43	147.27	151.1					
162	323.6	140	144	148					
163	325.4	137.2	140.9	145					
164	327.2	134	138	141					
165	329	131	135	138					
166	330.8	128	132	135					
167	332.6	126	129	132					
168	334.4	123	126	130					
169	336.2	120	124	127					
170	338	118	121	124					
171	339.8	115	118	122					
172	341.6	113	116	119					
173	343.4	110	113	117					
174	345.2	108	111	114					
175	347	106	109	112					
176	348.8	104	107	109					
177	350.6	101	104	107					
178	352.4	99	102	105					
179	354.2	97	100	103					
180	356	95	98	101					
181	357.8	93.4	96.1	99					
182	359.6	91.5	94.1	96.8					
183	361.4	89.6	92.3	94.9					

APPENDIX Q — TRANSID 2 THERMISTOR TROUBLESHOOTING INFORMATION

TRANSID 2 THERMISTORS — RESISTANCE (OHMS) VS. TEMPERATURE (cont'd)

Retarder Thermistor					Sump Thermistor				
Degree C	Degree F	Lo Ohms	Nom Ohms	Hi Ohms	Degree C	Degree F	Lo Ohms	Nom Ohms	Hi Ohms
184	363.2	87.8	90.4	93					
185	365	86.1	88.6	91.1					
186	366.8	84.3	86.8	89.4					
187	368.6	82.7	85.1	87.6					
188	370.4	81	83.4	85.9					
189	372.2	79.4	81.8	84.2					
190	374	77.8	80.2	82.6					
191	375.8	76.3	78.7	81					
192	377.6	74.8	77.1	79.4					
193	379.4	73.4	75.6	77.9					
194	381.2	71.9	74.2	76.4					
195	383	70.5	72.8	75					
196	384.8	69.2	71.4	73.6					
197	386.6	67.84	70.02	72.20					
198	388.4	66.54	68.70	70.86					
199	390.2	65.27	67.41	69.54					
200	392	64.03	66.14	68.25					
201	393.8	62.82	64.91	65.99					
202	395.6	61.64	63.70	65.76					
203	397.4	60.00	63.00	65.00					
204	399.2	59.30	61.40	63.00					